

GROUP 6 TRAVEL DEVICE

1. REMOVAL AND INSTALL

1) REMOVAL

- (1) Swing the work equipment 90° and lower it completely to the ground.
- (2) Operate the control levers and pedals several times to release the remaining pressure in the hydraulic piping.
- (3) Loosen the breather slowly to release the pressure inside the hydraulic tank.

▲ Escaping fluid under pressure can penetrate the skin causing serious injury.

※ When pipes and hoses are disconnected, the oil inside the piping will flow out, so catch it in oil pan.

- (4) Remove the track shoe assembly.
For details, see **removal of track shoe assembly**.
- (5) Remove the cover.
- (6) Remove the hoses.
※ Fit blind plugs to the disconnected hoses.
- (7) Remove the bolts and the sprocket.
- (8) Sling travel device assembly (1).
- (9) Remove the mounting bolts (2), then remove the travel device assembly.
· Weight : 620 kg (1370 lb)

2) INSTALL

- (1) Carry out installation in the reverse order to removal.
- (2) Bleed the air from the travel motor.
 - ① Remove the air vent plug.
 - ② Pour in hydraulic oil until it overflows from the port.
 - ③ Tighten plug lightly.
 - ④ Start the engine, run at low idling, and check oil come out from plug.
 - ⑤ Tighten plug fully.
- (3) Confirm the hydraulic oil level and check the hydraulic oil leak or not.

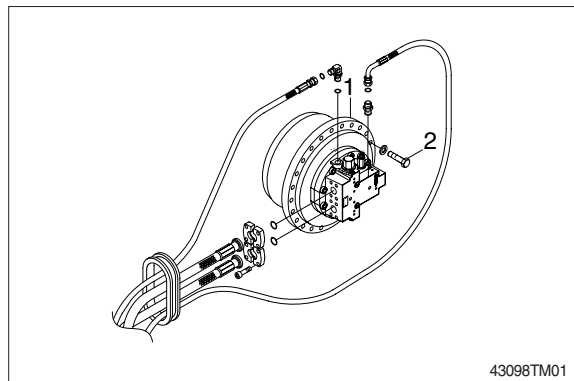

2. TRAVEL MOTOR

1) STRUCTURE

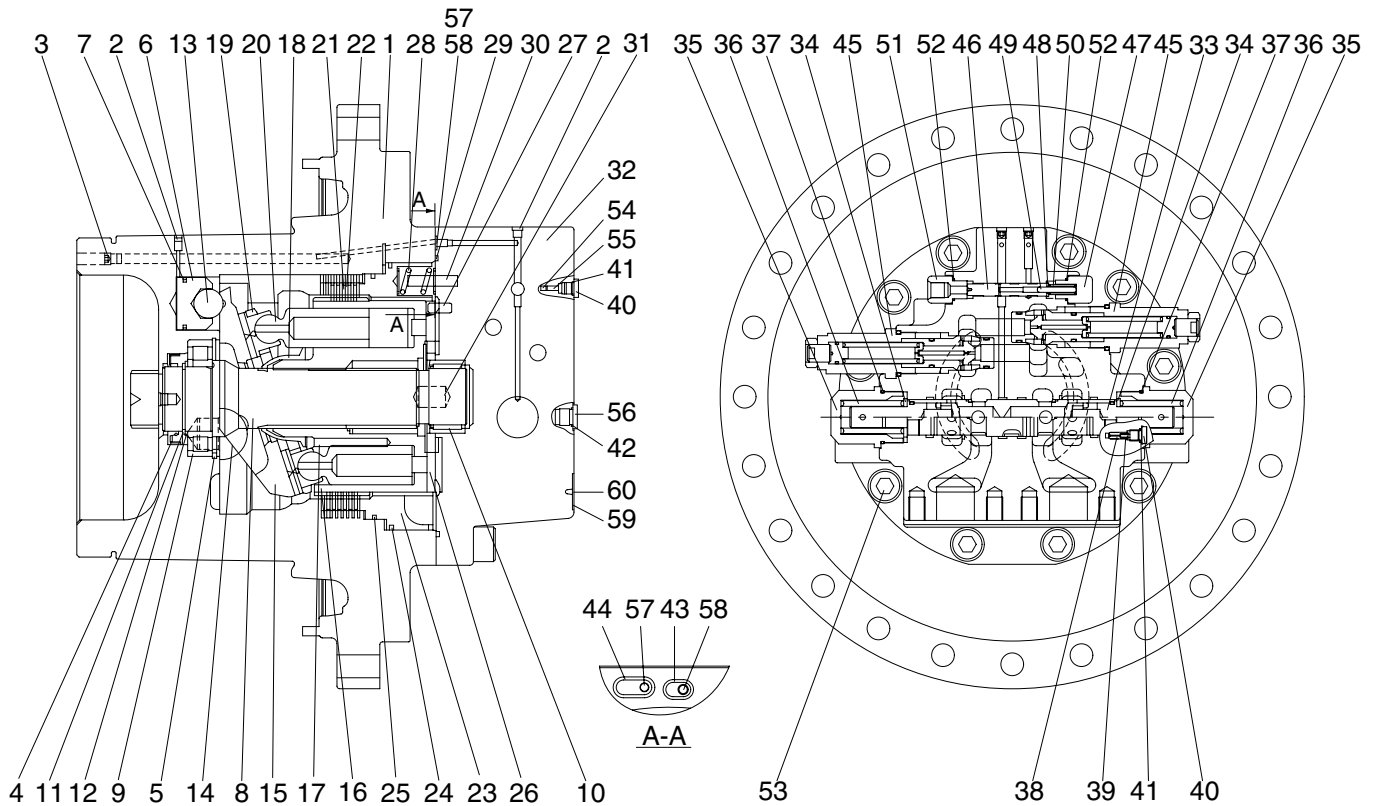

43092TM02

1	Casing	21	Friction plate	41	O-ring
2	Plug	22	Separated plate	42	O-ring
3	Plug	23	Parking piston	43	O-ring
4	Oil seal	24	D-ring	44	O-ring
5	Snap ring	25	D-ring	45	Relief valve assy
6	Piston	26	Valve plate	46	Spool
7	Piston seal	27	Parallel pin	47	Plug
8	Shaft	28	Spring	48	Spring seat
9	Cylinder roller bearing	29	O-ring	49	Parallel pin
10	Needle bearing	30	Spring pin	50	Spring
11	Snap ring	31	Parallel pin	51	Connector
12	Thrust plate	32	Rear cover	52	O-ring
13	Steel ball	33	Main spool assy	53	Hexagon socket head bolt
14	Pivot	34	Spring seat	54	Check valve
15	Swash plate	35	Plug	55	Spring
16	Cylinder block	36	Spring	56	Plug
17	Spring	37	O-ring	57	Restrictor
18	Ball guide	38	Restrictor	58	Restrictor
19	Retainer plate	39	Spring	59	Name plate
20	Piston assy	40	Plug	60	Rivet

2) TOOLS AND TIGHTENING TORQUE

(1) Tools

Tool name	B-size	Name of part applied
Hexagonal L-wrench	4	Plug (2)
	5	Plug (3), Plug (40)
	6	Plug (56)
	14	Hex (53)
Socket wrench/Spanner	21	Plug (47), Connector (51)
	30	Relief valve (45)
	41	Plug (53)
Snap ring plier (for holes, axis)		Snap ring (5), Snap ring (11)
Solder hammer		Needle bearing (10), Pin (27), Spring pin(30)
Torque wrench		Size : 500, 700, 5000
Jig for assembling oil seal		Oil seal (4)

(2) Tightening torque

Part name	Item	Size	Torque	
			kgf·m	lbf·ft
Plug	2	NPTF 1/16	1.1±0.1	8.0±0.72
Plug	3	PT 1/8	1.3±1.0	9.4±7.2
Plug	35	M45×1.5	45±4.5	325±32.5
Plug	40	PF 1/8	3.0±0.3	21.7±2.17
Relief valve assy	45	-	26±2.6	188±18.8
Plug	47	PF 3/8	5.5±0.5	39.8±3.6
Connector	51	-	5.5±0.5	39.8±3.6
Hex socket head bolt	53	M18×55	33±3.3	239±23.9
Plug	56	PF 1/4	4.5±0.5	32.5±3.6

3. DISASSEMBLING & ASSEMBLING OF TRAVEL MOTOR

1) GENERAL INSTRUCTIONS

- ▲ **Combustibles such as white kerosene are used for washing parts.**
These combustibles are easily ignited, and could result in fire or injury.
Be very careful when using.
 - ▲ **Internal parts are coated with hydraulic fluid during disassembling and are slippery.**
If a part slips out of your hand and falls, it could result in bodily injury or could damage the park.
Be very careful when handling.
- (1) Generally, hydraulic equipment is precisely manufactured and clearances between each parts are very narrow. Therefore, disassembling and assembling works should be performed on the clean place where dusts hardly gather. Tools and kerosene to wash parts should also be clean and handled with great care.
 - (2) When motor is removed from the host machine, wash around the ports sufficiently and put the plugs so that no dust and/or water may invade. Take off these plugs just before the piping works when re-attach it to the host machine.
 - (3) Before disassembling, review the sectional drawing and prepare the required parts, depending on the purpose and the range of disassembling.
Seals, O-rings, etc., if once disassembled, are not reusable.
There are some parts that should be replaced as a subassembly.
Consult with the parts manual in advance.
 - (4) The piston can be inserted to whichever cylinder block for the initial assembling.
However, their combination should not be changed if they are once used. To reuse them, put the matching mark on both pistons and cylinder block before disassembling.
- ▲ **Take great care not to pinch your hand between parts while disassembling nor let fall parts on your foot while lifting them.**

2) DISASSEMBLING TRAVEL MOTOR

- (1) Disassemble relief valve assy (45) from rear cover (32) using spanner or torque wrench.

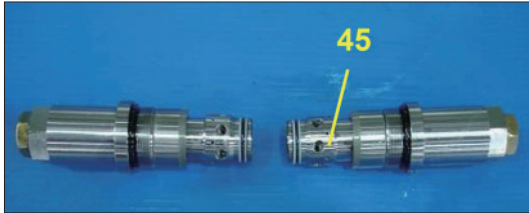

43098TM02

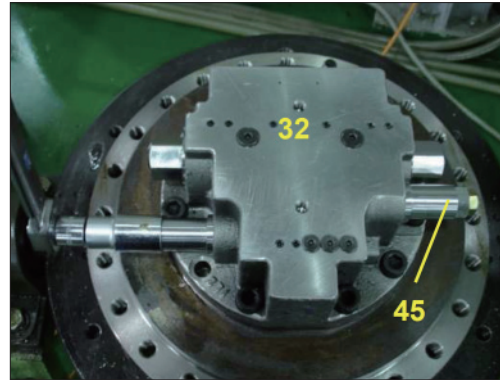

43098TM03

- (2) Disassemble main spool cover (35) from rear cover (32) and then disassemble spring (36), spring seat (34), main spool assy (35) in regular sequence.

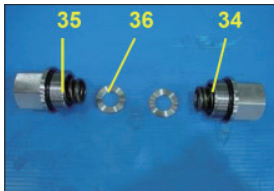

43098TM04

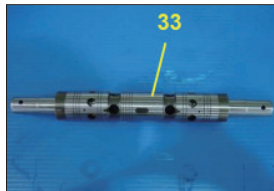

43098TM05

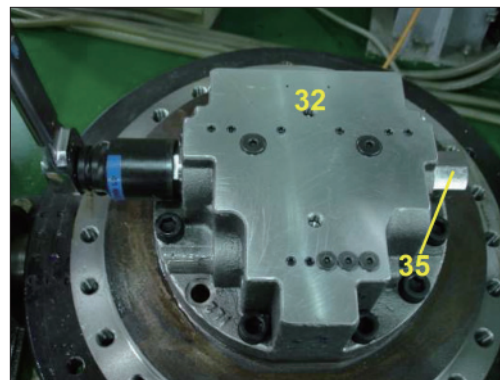

43098TM06

- (3) Disassemble wrench bolt (53, 10EA) using torque wrench.

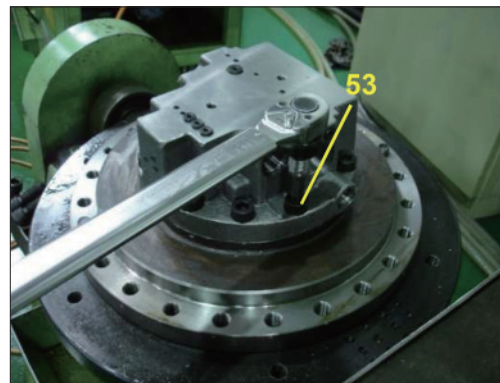

43098TM07

- (4) Take out rear cover (34) from casing (1).



43098TM08

(5) Disassemble parking piston (23) using jig.



43098TM09

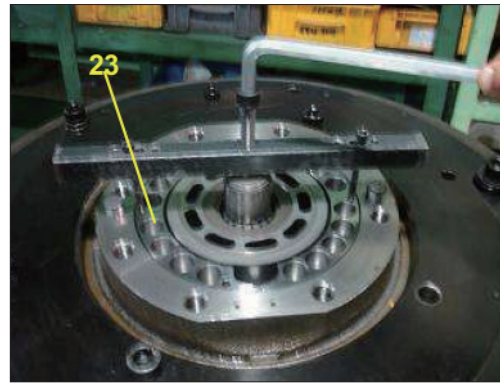

43098TM10

(6) Disassemble separated plate (22, 7EA) and friction plate (21, 6EA).



43098TM11

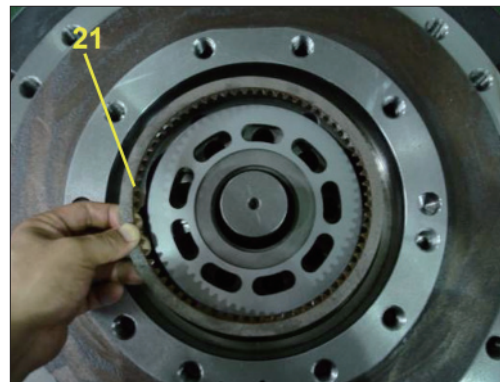

43098TM12

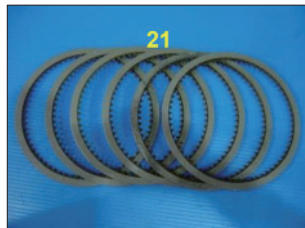

43098TM13

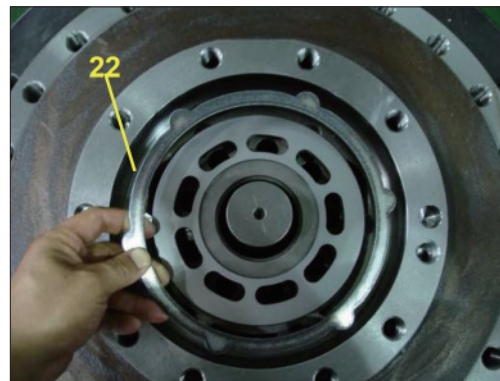

43098TM14

(7) Remove cylinder block kit.
It is easier to work by placing the casing (1) horizontal.

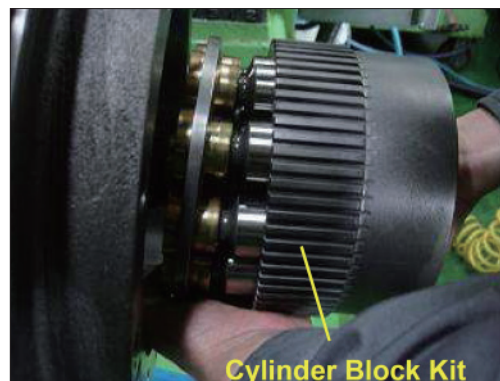

43098TM15

(8) Disassemble cylinder block (16), retainer plate (19), piston assy (20), ball guide (18) and spring (17) from cylinder block kit.



43098TM16

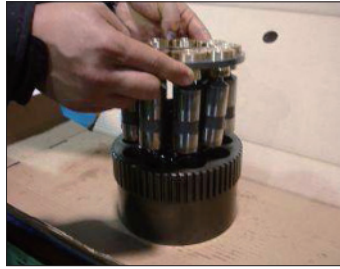

43098TM17

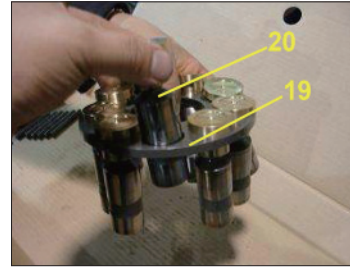

43098TM18

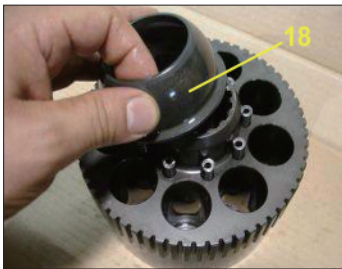

43098TM19

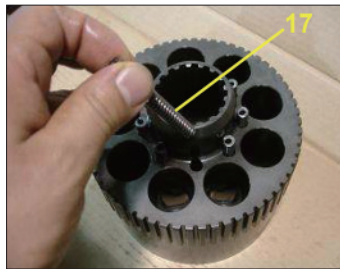

43098TM20

(9) Disassemble swash plate (15) from shaft casing (1).



43098TM21



43098TM22

(10) Disassemble steel ball (13) and swash piston (6).

※ Hole in the casing (1) of two speed line is decomposed by injecting oil.

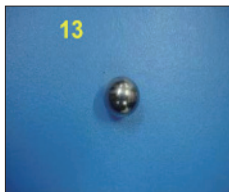

43098TM23

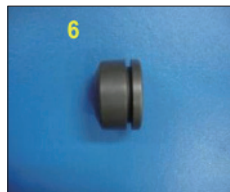

43098TM24

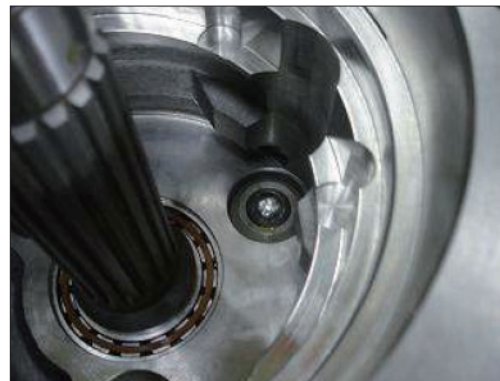

43098TM25

(11) Disassemble pivot (14, 2EA) from casing (1).

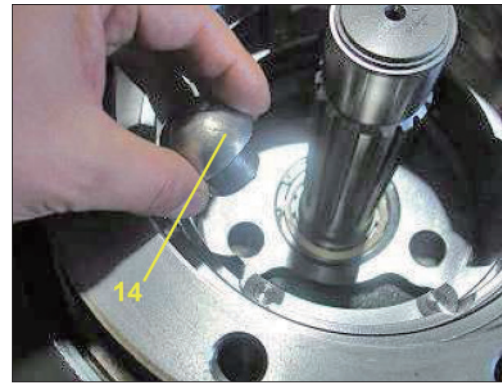

43098TM26

(12) Disassemble snap ring (5) using pliers.



43098TM27

(13) In the casing (1), the arrow part of the shaft (8) using a rubber mallet taps and then disassemble the shaft (8) and bearing-roller (9) to the other side.



43098TM28

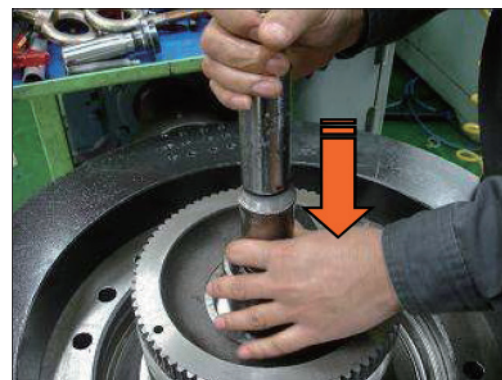

43098TM29

(14) Disassemble valve plate (28) from rear cover (32).

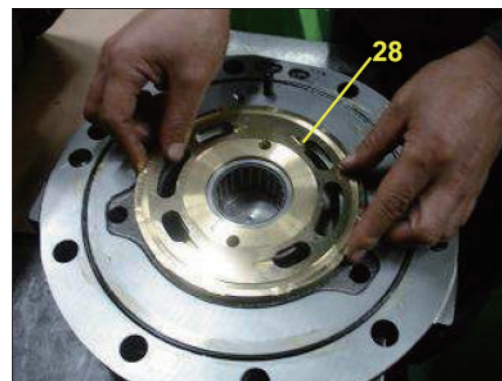

43098TM30

(15) Disassemble plug (47), connector (51) from rear cover (32) and then disassemble spring (50), spring-seat (50), pin – parallel (49), spool (47) in regular sequence.

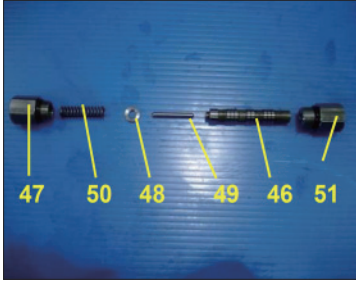

43098TM31

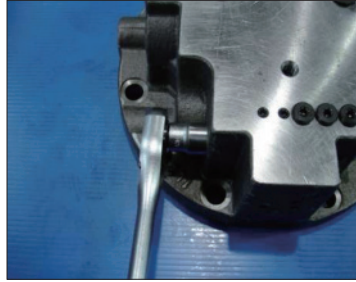

43098TM32

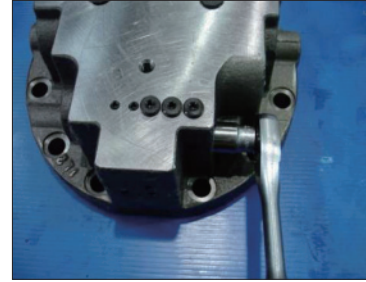

43098TM33

(16) Disassemble plug (40) from rear cover (32) and then disassemble spring (39), restictor (38) from rear cover (34) in regular sequence.

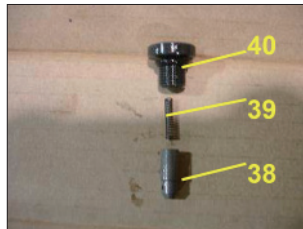

43098TM34

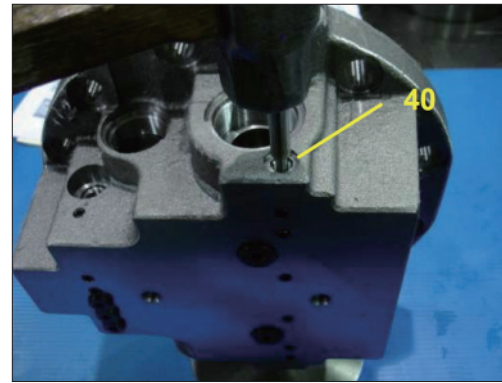

43098TM35

(17) Disassemble plug (40) from rear cover (34) and then disassemble spring(55), check valve (54) from rear cover (32) in regular sequence.

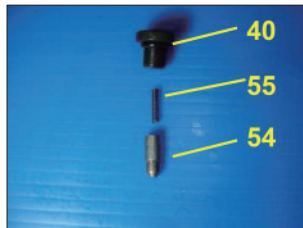

43098TM36

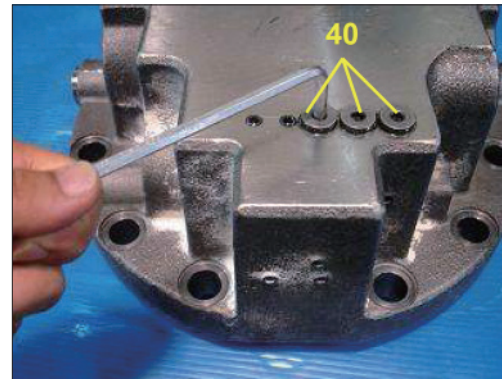

43098TM37

(18) Disassemble plug (56) from rear cover (32).

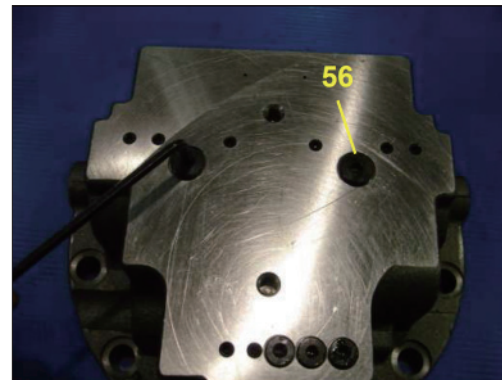

43098TM38

3) ASSEMBLING TRAVEL MOTOR - REAR COVER ASSY

(1) Insert check valve (55), spring (56) into rear cover (32) and then assemble plug (40) using torque-wrench.

·Tightening torque : 3.0 ± 0.3 kgf·m
(21.7 ± 2.17 lbf·ft)



43098TM39

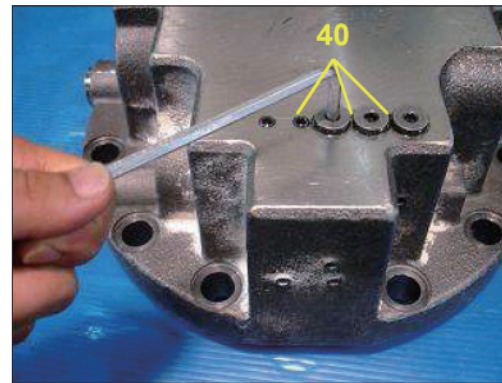

43098TM40

(2) Insert restrictor (38), spring (39) into rear cover (32) and then assemble plug (40) using torque-wrench.

·Tightening torque : 3.0 ± 0.3 kgf·m
(21.7 ± 2.17 lbf·ft)

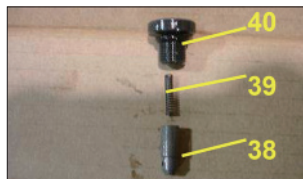

43098TM41

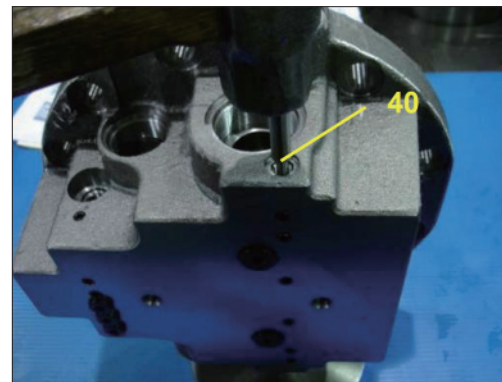

43098TM42

(3) Apply loctite #242 on the 14 plug (2) and then assemble them into rear cover (32).



43098TM43

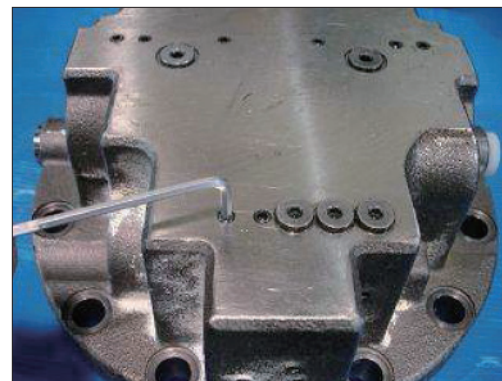

43098TM44

(4) Assemble 2 plug (42, 56) using torque-wrench.

·Tightening torque : 4.5 ± 0.5 kgf·m
(32.5 ± 3.62 lbf·ft)



43098TM45

(5) Insert spool (46), parallel pin (49), spring seat (48) and spring (50) in regular sequence and then assemble plug (47), connector (51) using torque-wrench.

·Tightening torque : 5.5 ± 0.5 kgf·m (39.8 ± 3.62 lbf·ft)

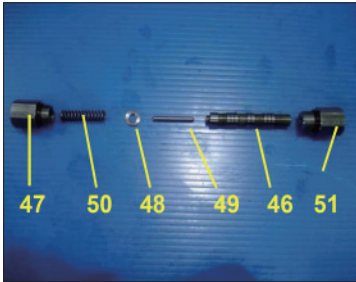

43098TM46

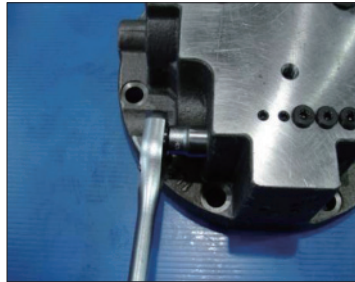

43098TM47

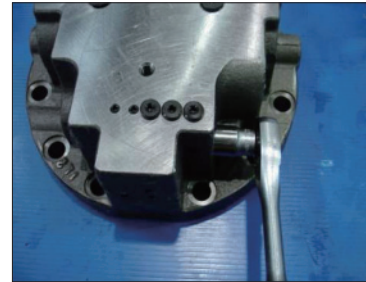

43098TM48

(6) Press needle bearing (10) into rear cover (32) using jig.



43098TM49

(7) Assemble spring pin (30), parallel pin (27) using small hammer.

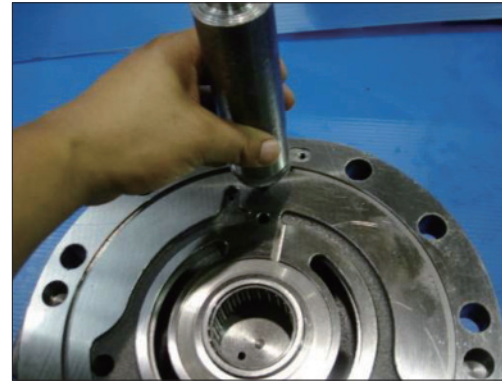

43098TM50

(8) Apply loctite #242 on the restrictor (57, 58) and then assemble restrictor (57, 58), O-ring (43, 44) into rear cover (34).

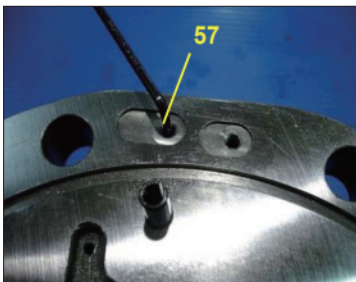

43098TM51



43098TM52

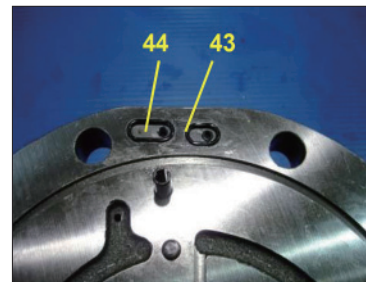

43098TM53

(9) Assemble valve plate (26) into rear cover (32).

※ **Apply grease to the valve plate contact and then assemble it into rear cover (32).**

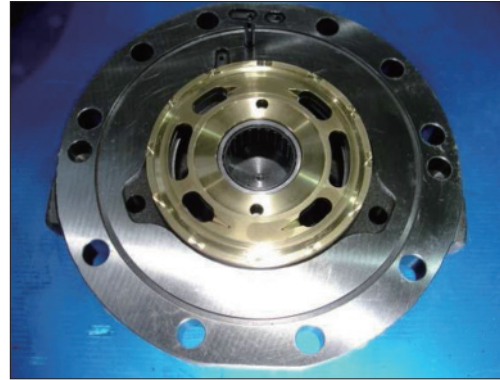

43098TM54

(10) Apply grease to the O-ring (29), and then assemble it into rear cover (34).

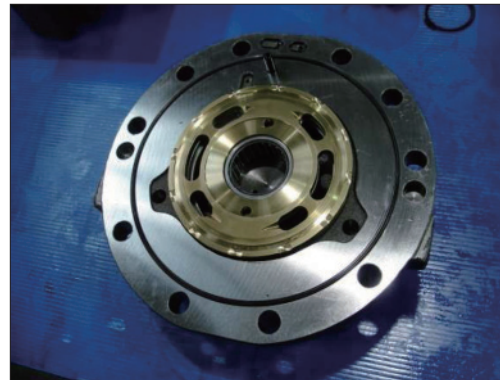

43098TM55

(11) Assemble the heated roller bearing (9) onto the shaft (8) and then assemble snap ring (6) into shaft (8).

① The temperature of the roller bearing : 100°C.

※ **Using tool : Heater.**

※ **Be careful not to damage the sliding surface for the oil seal on the shaft.**

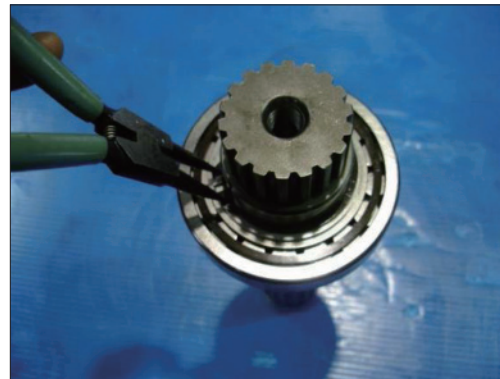

43098TM56



43098TM57



43098TM58



43098TM59

(12) Install casing (1) into assembling jig.



43098TM60

(13) Assemble plug (2), (3) into casing (1).

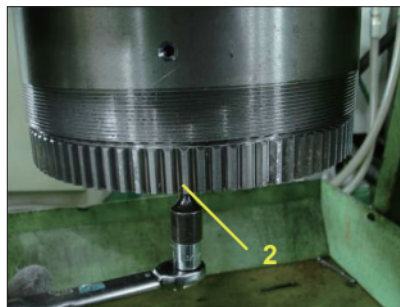

43098TM61



43098TM62

(14) Assemble oil seal (3) into casing (1) with assembling jig.

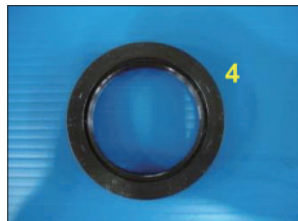

43098TM63

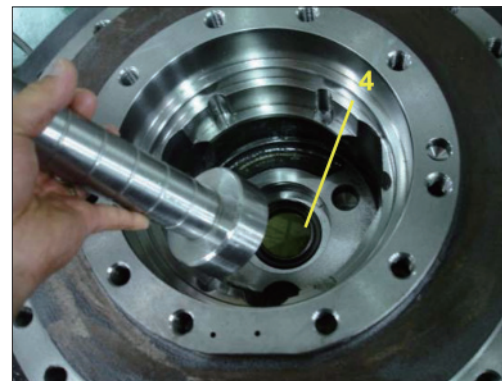

43098TM64

(15) Insert assembled shaft assy in the direction of the arrow into casing(1) using a rubber mallet.

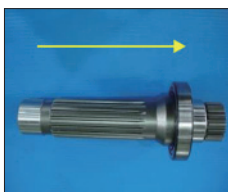

43098TM65



43098TM66

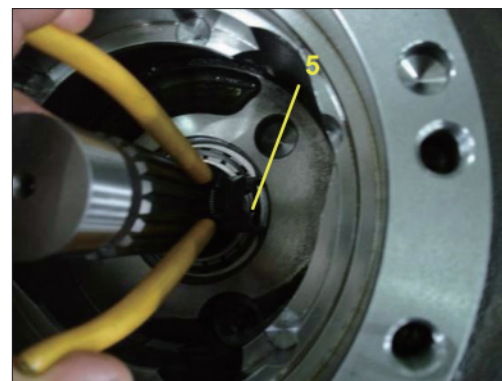

43098TM67

(16) Apply the grease to pivot (14, 2EA) and then assemble pivot (14) into casing(1).

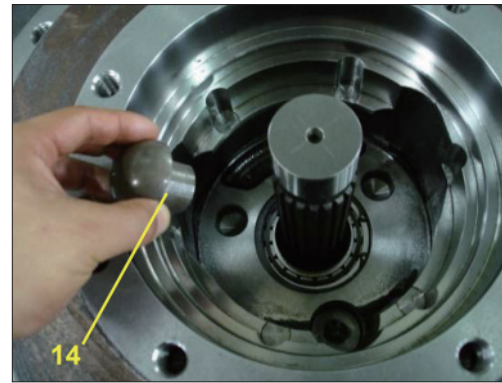

43098TM68

(17) Warm piston seal (7) and assemble it on swash piston (6) and then bind the piston seal (7) with a bend for a minute.
Remove the bend and assemble it into casing (1).

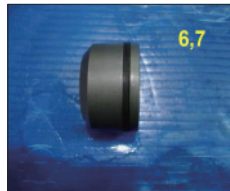

43098TM69

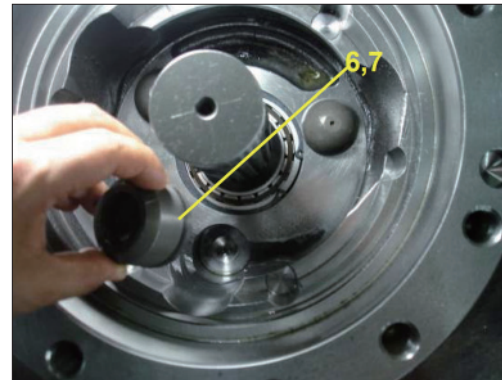

43098TM70

(18) Apply the grease to steel ball (15) and then assemble steel ball (15) into casing (1).



43098TM71

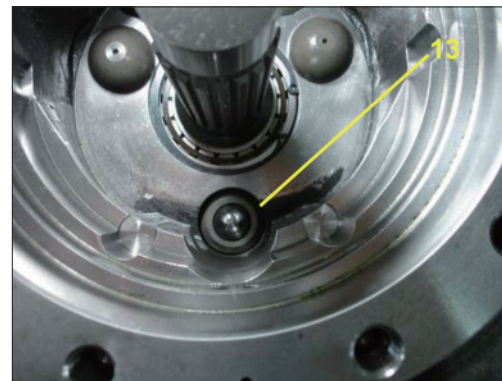

43098TM72

(19) Apply the grease to swash plate (15) and then assemble swash plate (15) into casing (1).



43098TM73

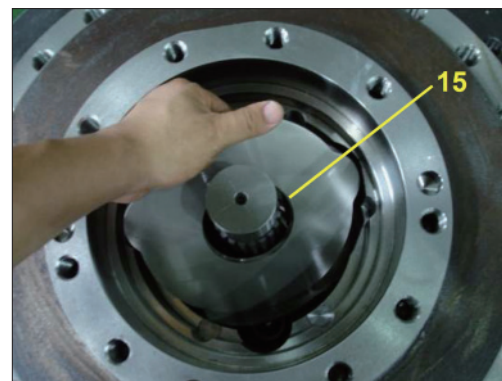

43098TM74

(20) Assemble spring (17), ball guide (18), retainer plate (19), piston assy (20) into cylinder block (16) in regular sequence.

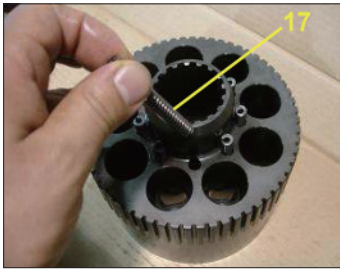

43098TM75

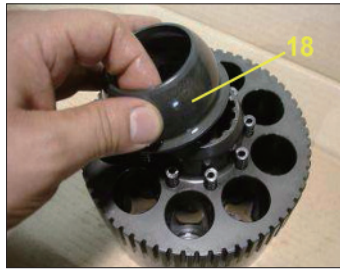

43098TM76

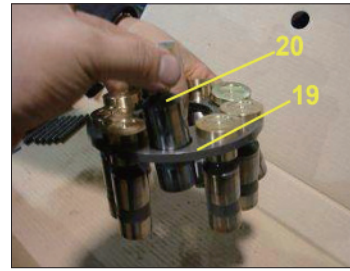

43098TM77

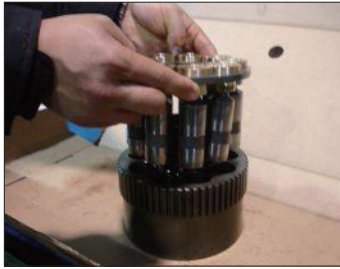

43098TM78



43098TM79

(21) Assemble cylinder block kit into casing (1).

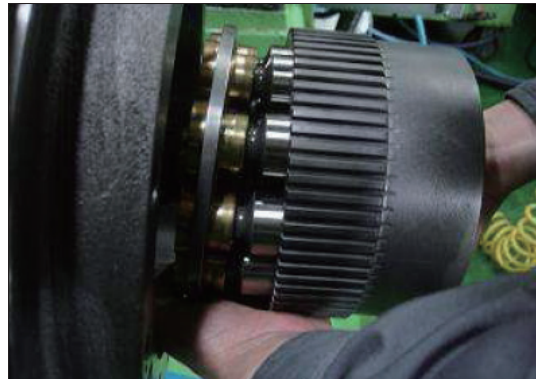

43098TM80

(22) Assemble separated plate (21), friction plate (22) into cylinder block in regular sequence.

Friction plate : 6EA

Separated plate : 7EA

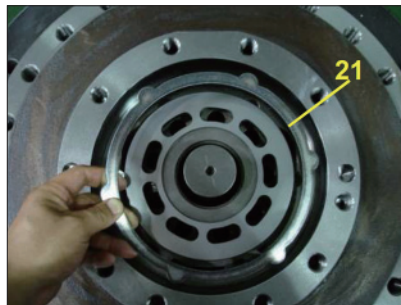

43098TM81

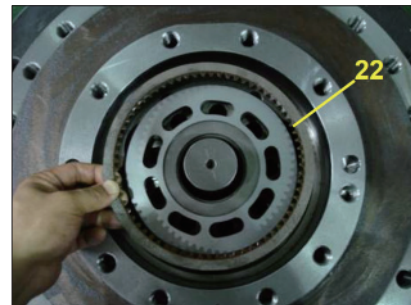

43098TM82

(23) Assemble parallel pin (31) into casing(1).

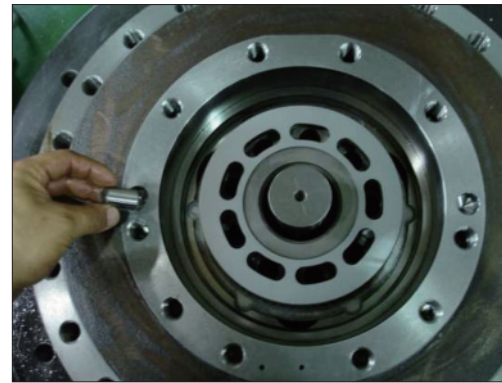

43098TM83

(24) Apply the grease to D-ring (24, 25) and then assemble them into parking piston (23).

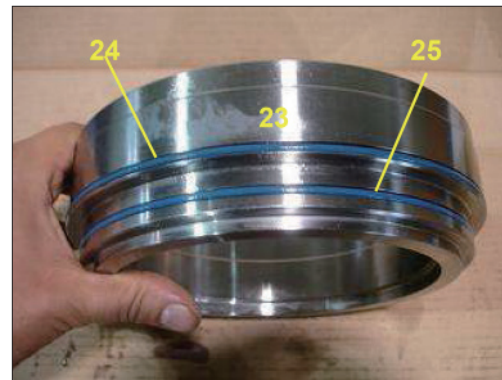

43098TM84

(25) Assemble parking piston into casing using jig.



43098TM85

(26) Assemble parking spring (28, 14EA).

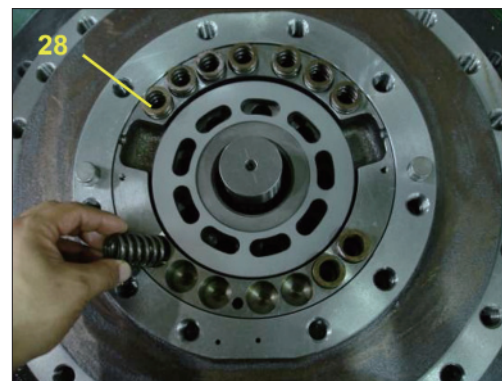

43098TM86

(27) Put on the rear cover (32) on the casing (1).

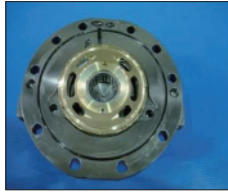

43098TM87

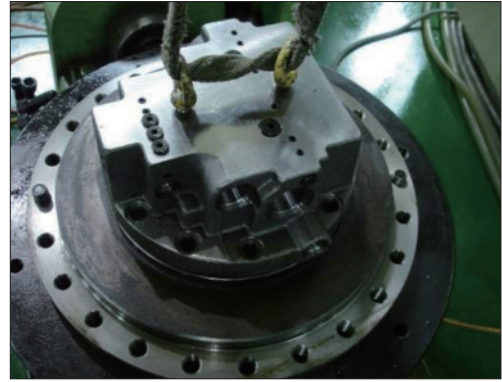

43098TM88

(28) Assemble rear cover (32) into casing (1) and then tighten the wrench bolt (53) using torque wrench.

- Tightening torque : 33 ± 3.3 kgf·m
(239 ± 23.9 lbf·ft)

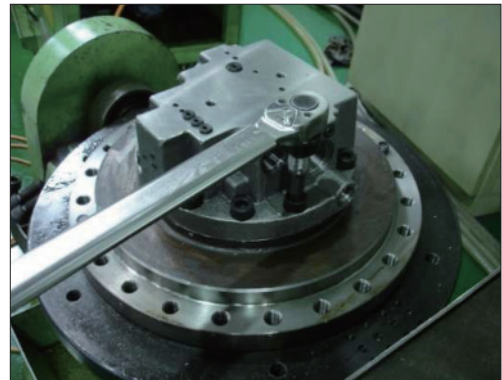

43098TM89

(27) Assemble main spool assy (33) into rear cover (32) after checking the direction to be correct.



43098TM90

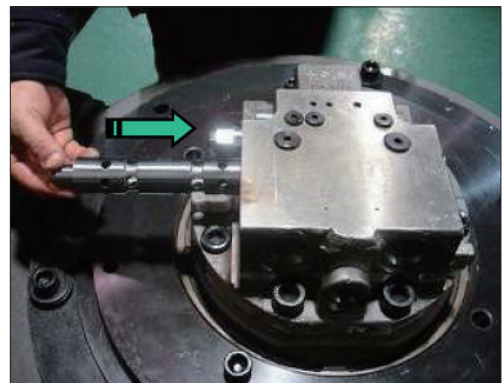

43098TM91

(30) Assemble spring (37), plug (36) into rear cover (34) in regular sequence and then plug (36) into rear cover (34) using torque wrench.

- Tightening torque : 45 ± 4.5 kgf·m
(325 ± 32.5 lbf·ft)



43098TM92



43098TM93

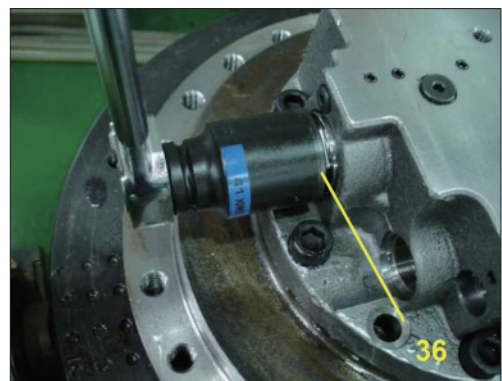

43098TM94

(31) Assemble relief valve assy (45) using torque-wrench.

· Tightening torque : 26 ± 2.6 kgf·m
(188 ± 18.8 lbf·ft)

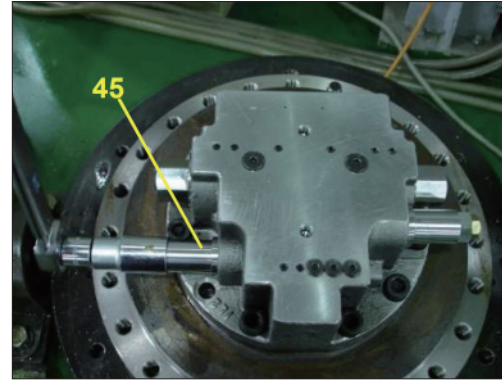

43098TM95

4. TRAVEL REDUCTION GEAR

1) STRUCTURE

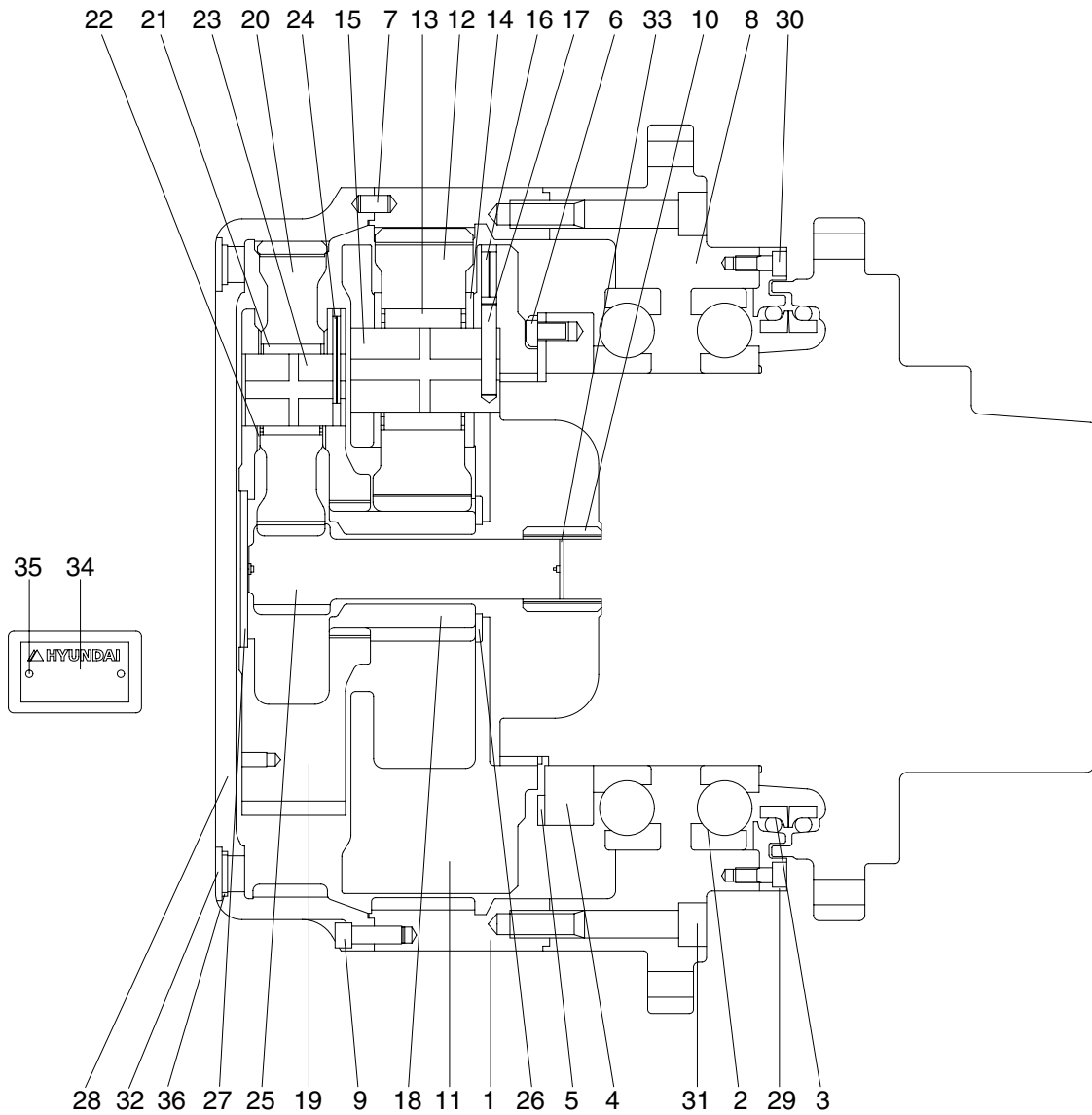

43092TM03

1	Ring gear	13	Needle bearing 2	25	Sun gear 1
2	Ball bearing	14	Thrust washer 2	26	Thrust plate
3	Floating seal assy	15	Carrier pin 2	27	Thrust plate
4	Ring nut	16	Spring pin 2	28	Cover
5	Lock plate	17	Solid pin 2	29	Cover seal
6	Hexagon socket head bolt	18	Sun gear 2	30	Hexagon socket head bolt
7	Parallel pin	19	Carrier 1	31	Hexagon socket head bolt
8	Housing	20	Planetary gear 1	32	Plug
9	Hexagon socket head bolt	21	Needle bearing 1	33	Snap ring
10	Coupling	22	Thrust washer 1	34	Name plate
11	Carrier 2	23	Carrier pin 1	35	Rivet
12	Planetary gear 2	24	Spring pin 1	36	O-ring

2) TOOL AND TIGHTENING TORQUE

(1) Tools

Tool name	B-size	Name of part applied
Hexagonal L-wrench	10	Hex socket head bolt (30)
	12	Hex socket head bolt (9)
	14	Plug (32)
	20	Hex socket head bolt (31)
Socket wrench/Spanner	12	Hex socket head bolt (6)
Hammer		Needle bearing (13, 21), Pin (15, 16, 17, 23, 24)
Torque wrench		Capable of tightening with the specified torques
Jig for assembling floating seal		Floating seal (3)
Bearing assembly jig		Arg-ball bearing (2)

(2) Tightening torque

Item	Name	Size	Torque	
			kgf.m	lbf.ft
4	Ring nut	M280	66±6.0	477±43.4
6	Hexagon head bolt	M12	8.8±0.9	63.7±6.5
9	Hexagon socket head bolt	M12	14.3±1.4	103±10.1
30	Hexagon socket head bolt	M10	6.3±0.6	45.5±4.3
31	Hexagon socket head bolt	M20	53±5.0	383±36.2
32	Plug	PF 3/4	10±1.0	72.3±7.2

5. DISASSEMBLING AND ASSEMBLING OF REDUCTION GEAR

1) GENERAL INSTRUCTIONS

- ▲ Combustibles such as white kerosene are used for washing parts.**
These combustibles are easily ignited, and could result in fire or injury.
Be very careful when using.
 - ▲ Internal parts are coated with gear oil during disassembling and are slippery.**
If a part slips off from your hand and falls, it could result in bodily injury or could damage the park.
Be very careful when handling.
- (1) Therefore, disassembling and assembling works should be performed on the clean place where dusts hardly gather.
Tools and kerosene to wash parts should also be clean and handled with great care.
- (2) Before disassembling, review the sectional drawing and prepare the required parts, depending on the purpose and the range of disassembling.
Seals, O-rings, etc., if once disassembled, are not reusable.
There are some parts that should be replaced as a subassembly.
Consult with the parts manual in advance.
- ▲ Take great care not to pinch your hand between parts while disassembling nor let fall parts on your foot while lifting them.**

2) DISASSEMBLING TRAVEL REDUCTION GEAR

(1) Ready for disassembling

- ① Reduction gear removed from machine usually covered with dirt, so clean it with cleaning liquid and dry it.
- ② Put reduction gear on stable place with drain port down side and remove oil plug (PF3/4) to pull-out gear oil through drain port.

※ **When the oil is hot, there are high chance to blow out hot oil because of the pressure difference between container and out side.**

- ③ Set reduction gear on work table.
- ④ Mark surface of cover, ring gear and housing for proper re-assembly.

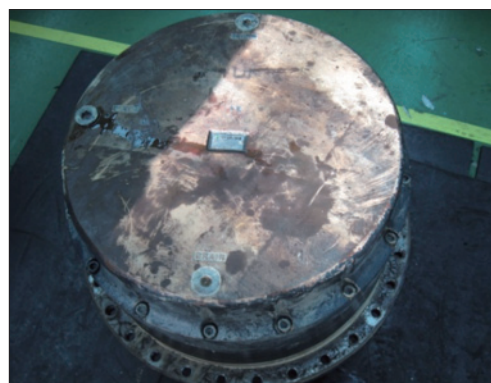

43098TR01

(2) Put reduction gear on work table to disassemble

- ① Set eye bolt (M20) into M20 tap hole on housing flange. Make reduction gear cover upper direction using hoist machine.

▲ **Be aware of safety. There are some chances of accidents when put down the reduction gear. Do not place the part fall on your foot.**



43098TR02

(3) Removing cover

- ① Remove 16 of hex socket head bolt (M12 × 35) connecting cover and ring gear using torque wrench.
- ② Using sharp tools to separate cover and ring gear. Put sharp tools into the gap between ring gear and cover and tap the tool tenderly.



43098TR03

(4) Remove thrust plate and No.1 carrier sub

- ① Remove thrust plate first, set eye bolt (M10) in No.1 carrier tap hole. After these, pull-up No.1 carrier assy slowly.

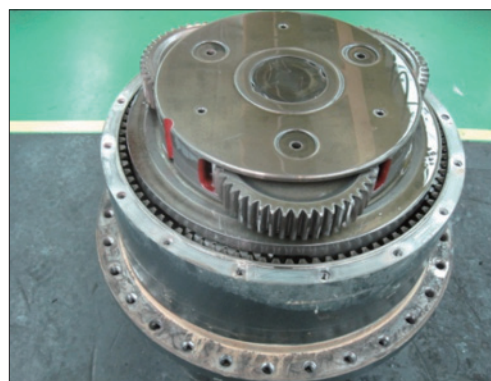

43098TR04

- ② Remove No.1 sun gear from reduction gear slowly.
※ When disassemble No.1 sun gear, be sure to keep vertical against ground with No.1 sun gear.

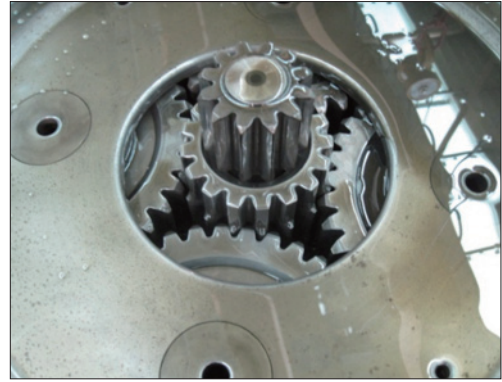

43098TR05

(5) Removing carrier sub No.2

- ① Remove No.2 sun gear slowly.
※ When disassemble No.2 sun gear, be sure to keep vertical against ground with No.2 sun gear.

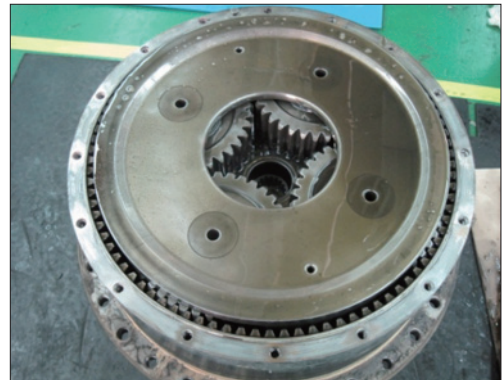

43098TR06

- ② Set eye bolt (M10) in No.2 carrier assy, pull-up slowly.



43098TR07

(6) Remove coupling

- ① Remove coupling on motor spline.

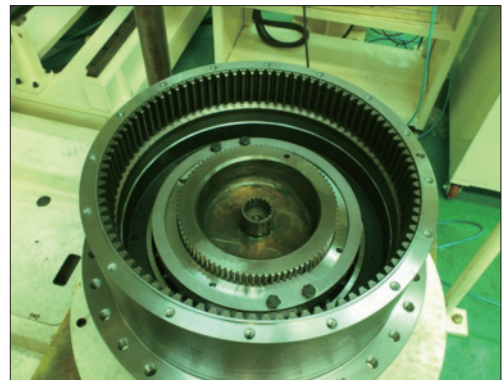

43098TR08

(7) Remove nut ring and lock plate

- ① Remove hex head bolt (M12×20) using torque wrench which is connecting ring and lock plate.
- ② Remove lock plate from motor casing spline.
- ③ Remove nut ring using designed tools.

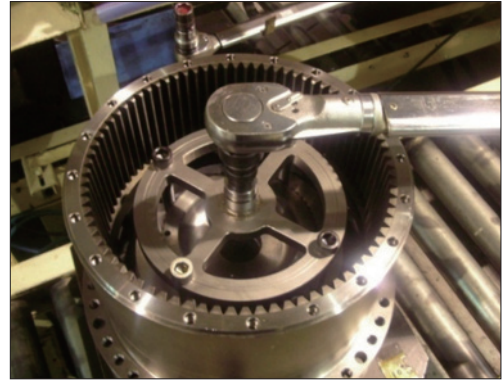

43098TR09

(8) Disassemble ring gear and housing

- ① Set eye bolt (M20) in flange of housing, pulling ring gear and housing from motor.

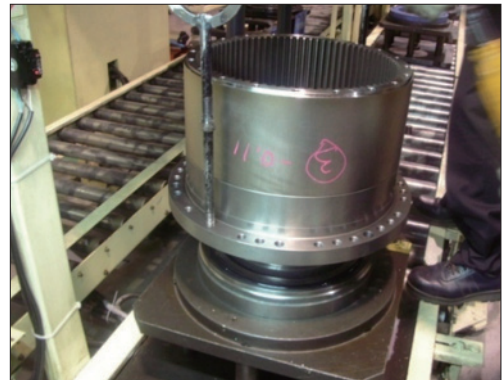

43098TR10

- ② Put disassembled ring gear and housing on work table. Be sure to set floating seal upper side, and remove floating seal.

※ Do not re-use floating seal.

- ③ Remove hex socket head bolt (M20×120) connecting housing and ring gear using torque wrench.
- ④ Put sharp tool into gap between ring gear and housing and tap it tenderly to separate gear and housing.

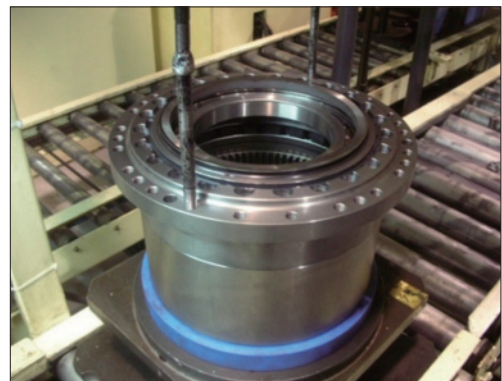

43098TR11

(9) Disassemble housing components

- ① Hex head bolt (M10×25) connecting housing and seal cover using torque wrench, and remove seal cover.



43098TR12

(10) Separate motor casing and floating seal

- ① Pull floating seal in motor casing slowly and remove floating seal from motor casing.
- ※ Do not re-use floating seal.

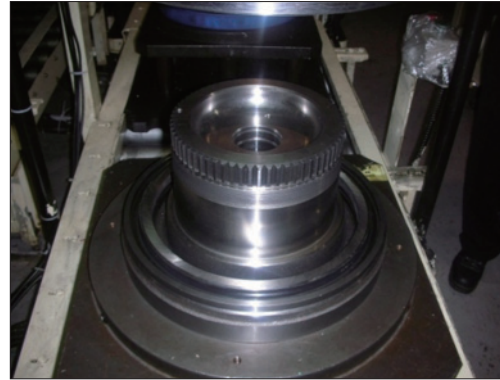

43098TR13

(11) Disassemble No. 1 carrier assy

- ① Put spring pin into No.1 spring pin hole using specially designed tool.



43098TR14

- ② Disassemble No.1 planetary gear, thrust washer, No.1 pin, needle bearing from No.1 carrier.

※ Do not re-use No. 1 pin.



43098TR15

(12) Disassemble No. 2 carrier assy

- ① Cut solid pin by pressing No. 2 pin using press machine.

▲ Be aware of scattering of components when operator use press machine.

- ② Disassemble No. 2 planetary gear, thrust washer, No. 2 pin, needle bearing from No. 2 carrier.

※ Do not re-use No. 2 pin.



43098TR16

3) ASSEMBLING TRAVEL REDUTION GEAR

(1) General precautions

- ① Clean all components with kerosene and dry them in shade. Remove all loctite with solvent.
Check the components.
Apply loctite #262 on thread of hex socket head bolt.
Be aware of dropping of parts on foot and safety accident.
Check the quantity of all parts in advance.
- ② Check the abnormality of thrust washer like twist or wear.
- ③ Check the surface of every gear. Whether there is pitting or crack on them.
- ④ Rolling the bearing and check the rolling condition and the noise.
- ⑤ Check the surface of floating seal and crack of O-ring.

(2) Carrier No. 1 assembly

- ① Set No.1 carrier on stable and even place.
- ② Put No.1 needle bearing in No.1 planetary gear and place No.1 thrust washer 2 pcs on both side of gear. Assemble gear in carrier.



43098TR17

- ③ Align spring pin hole of No.1 pin with No. 1 carrier spring pin hole and assemble No.1 pin accordingly.



43098TR18

- ④ Put spring pin into No.1 carrier using jig with force.



43098TR19

- ⑤ Caulking both side of pressed spring pin 180° using caulking jig.

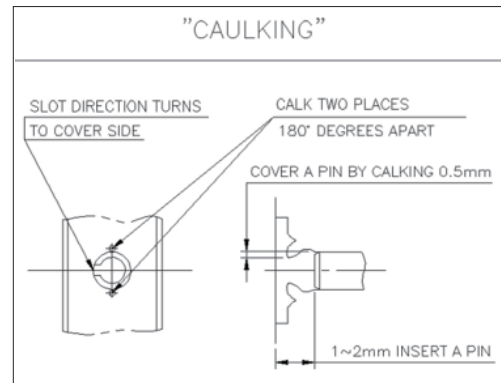

43098TR20

(3) Carrier No. 2 assembly

- ① Set No. 2 carrier on stable and even place.
- ② Put No.2 needle bearing in No.2 planetary gear and place No.2 thrust washer 2pcs on both side of gear. Assemble gear in carrier.
- ③ Align solid pin hole of No. 2 pin and No. 2 carrier spring pin hole. and assemble No. 2 pin accordingly.
- ④ After assembly solid pin, put spring pin with force.
- ⑤ Caulking both sides of pressed spring pin 180° using caulking jig.



43098TR21

(4) Assembling floating seal

- ① Wipe O-ring side of floating seal and contact surface of floating seal of motor casing with oil applied lint free towel, and press fitting floating seal into motor casing with special jig.
- ※ **Keep the floating seal vertical against ground.**

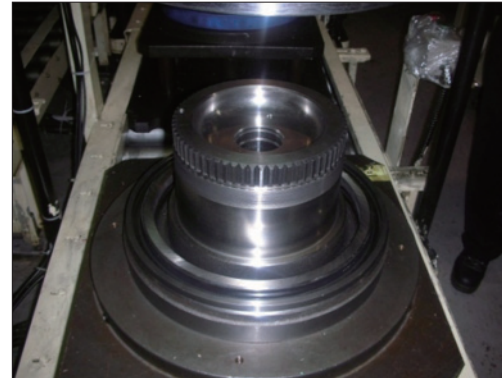

43098TR22

(5) Housing & main bearing

- ① Heating and cleaning housing with 60~70°C temperature.
- ② Set the housing on working table safely, press fitting main bearing into both side of housing.

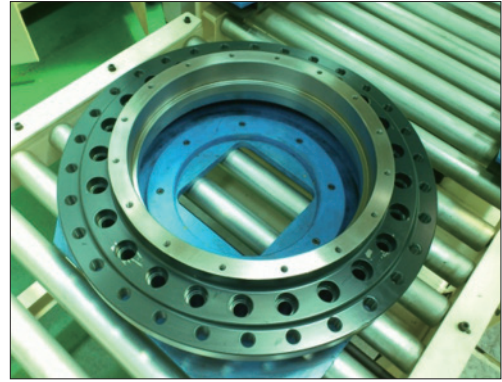

43098TR23

(6) Seal cover

- ① Apply three bond #1194 on contact surface of housing and seal cover, tighten hex socket head bolt (M10×25) with designed torque $6.3 \pm 0.6 \text{ kgf} \cdot \text{m}$ ($45 \pm 4.3 \text{ lbf} \cdot \text{ft}$) using torque wrench.



43098TR24

(7) Housing components and ring gear

- ① Apply three bond #1194 on the surface of ring gear and housing contact surface, tighten hex socket head bolt (M20×120) with designed torque $53 \pm 5.3 \text{ kgf} \cdot \text{m}$ ($383 \pm 38.3 \text{ lbf} \cdot \text{ft}$) using torque wrench.
- ② Wipe O-ring side of floating seal and contact surface of floating seal of seal cover with oil applied lint free towel, and press fitting floating seal into seal cover.

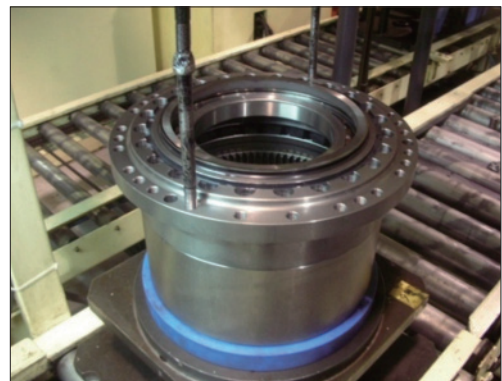

43098TR25

(8) Motor & assembled housing components assembly

- ① Set eye bolt (M20) in housing flange tap hole.
 - ② Assemble assembled housing components on motor using hoist.
- ※ Be sure set eye bolt firmly to keep operator safe.

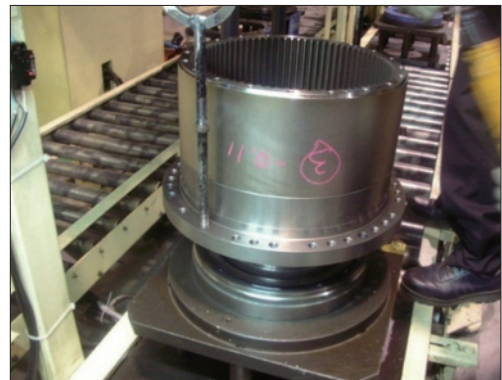

43098TR26

(9) Nut ring and lock plate

- ① Tighten nut ring with designed torque using torque wrench.
- ② Set lock plate along with bolt hole of nut ring and assemble them.
- ③ Tighten hex head bolt (M12×20) with designed torque $8.8 \pm 0.9 \text{ kgf} \cdot \text{m}$ ($63.7 \pm 6.5 \text{ lbf} \cdot \text{ft}$).

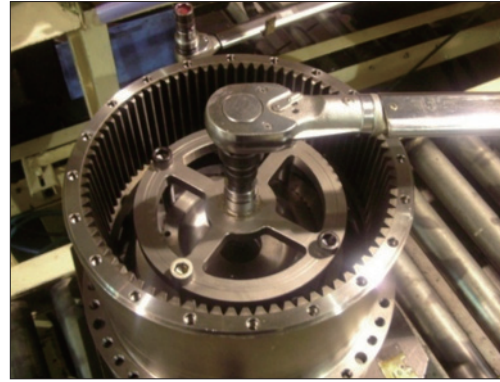

43098TR27

(10) Coupling

- ① Assembly coupling with motor's spline.

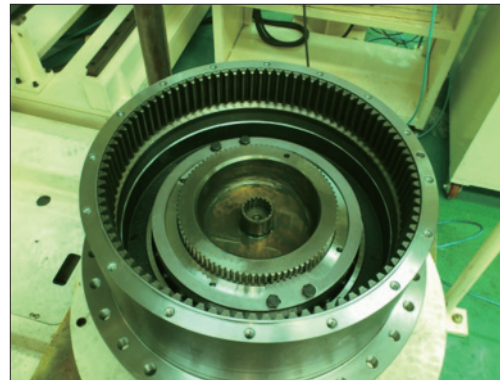

43098TR28

(11) No.2 carrier sub

- ① Set eye bolt (M10) in No.2 carrier assy, lift them using hoist and set down No.2 carrier assy into motor.



43098TR29

※ To set the align valve ports, refer to right drawing.

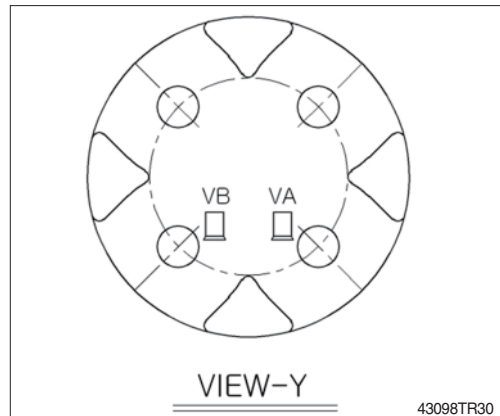

43098TR30

- ② Assemble No.2 sun gear into No.2 carrier assy.

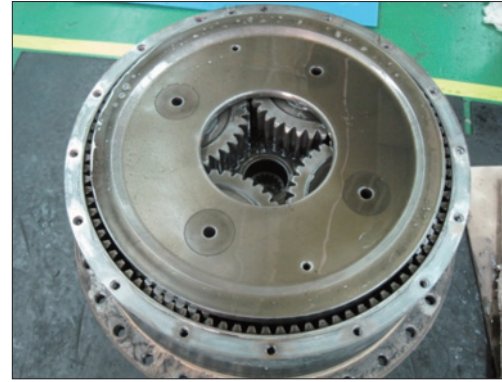

43098TR31

(12) No.1 carrier sub assembly

- ① Set eye bolt (M10) in No.1 carrier tap hole and set down No.1 carrier assy slowly.
- ② Assemble No.1 sun gear and No.1 carrier assy.
- ③ Assemble thrust plate and carrier.



43098TR32

(13) Cover assembly

- ① Put parallel pin ($\varnothing 13 \times 20$) into parallel pin hole of ring gear with rubber hammer.
- ② Apply three bond #1194 on cover contacting surface of ring gear and assemble cover.
- ③ Tighten 16 of hex socket head bolt (M12 \times 35) with designed torque 14.3 ± 1.4 kgf · m (103 ± 10.1 lbf · ft) using torque wrench.



43098TR33

(14) Putting gear oil

- (1) Put gear oil 12 ± 0.5 liter through fill port and check the oil level.
- (2) Tighten oil plug with torque 10 ± 0.1 kgf · m (72.3 ± 0.72 lbf · ft).