

GROUP 7 ENGINE OVERHEAT PREVENTION SYSTEM (CLUSTER TYPE 1)

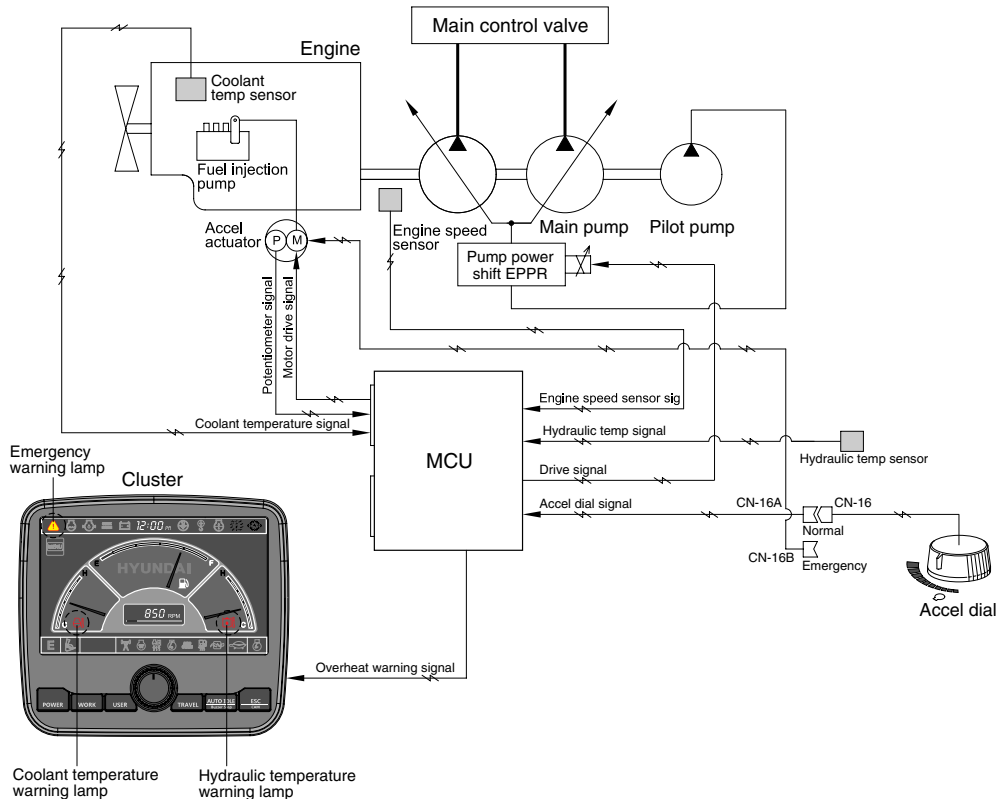

3009SH5MS09A

1. The engine coolant temperature or the hydraulic oil temperature is overheated over 100°C, the warning lamp is ON and the pump input torque or the engine speed is reduced as below logic table.

2. LOGIC TABLE

Description		Condition	Function
First step warning	Activated	- Coolant or hydraulic oil temperature : Above 100°C	- Warning lamp & buzzer : ON - Pump input torque is reduced.
	Canceled	- Coolant or hydraulic oil temperature : Less than 95°C	- Return to pre-set the pump input torque.
Second step warning	Activated	- Coolant or hydraulic oil temperature : Above 105°C	- Emergency warning lamp pops up on the center of LCD and the buzzer sounds. - Engine speed is reduced after 10 seconds.
	Canceled	- Coolant or hydraulic oil temperature : Less than 100°C	- Return to pre-set the engine speed. - Hold pump input torque on the first step warning.

ENGINE OVERHEAT PREVENTION SYSTEM (CLUSTER TYPE 2)

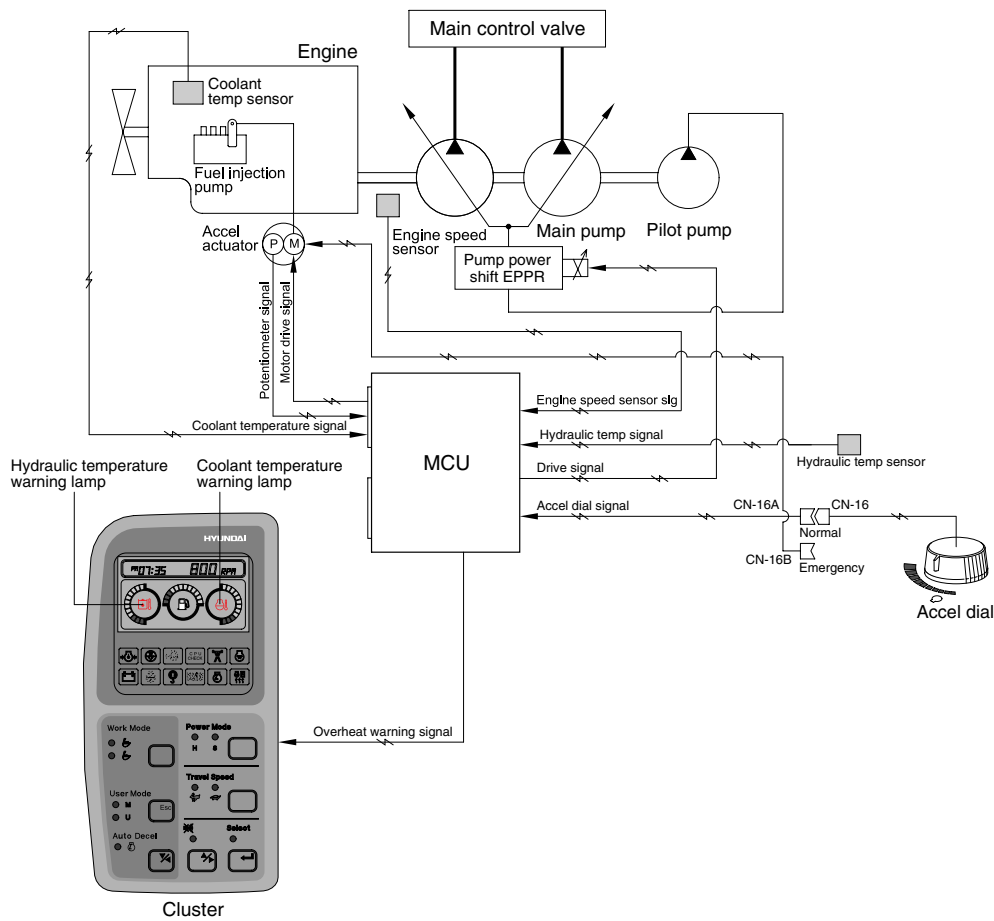

3009SH5MS27

1. MCU receives engine coolant temperature through the temperature sensor and when the engine coolant boils up to 110°C, it sends overheat warning signal to the cluster and decrease the engine speed same as accel dial 7 position.
2. If the coolant temperature drops less than 100°C, the MCU returns the mode to the mode set before. And if mode set is changed during the function, the MCU cancels the function. Even if the overheat prevention function is canceled by mode change, the overheat warning lamp turns OFF only when the coolant temperature is less than 100°C.

3. LOGIC TABLE

Description	Condition	Function
Actuated	- Coolant temperature : Above 110°C - Accel dial set : Above 8	- Engine rpm drop to accel dial 7 position - Overheat warning lamp & buzzer : ON
Canceled	- Coolant temperature : Less than 100°C - Changed mode set by operator ※ If any of the above conditions is applicable, engine overheat prevention function is canceled	- Return to the mode and accel dial set before - Hold on the changed set
Overheat warning lamp	- Coolant temperature : Less than 100°C	- Overheat warning lamp : OFF