

GROUP 3 TRACK AND WORK EQUIPMENT

1. TRACK

1) TRACK ROLLER

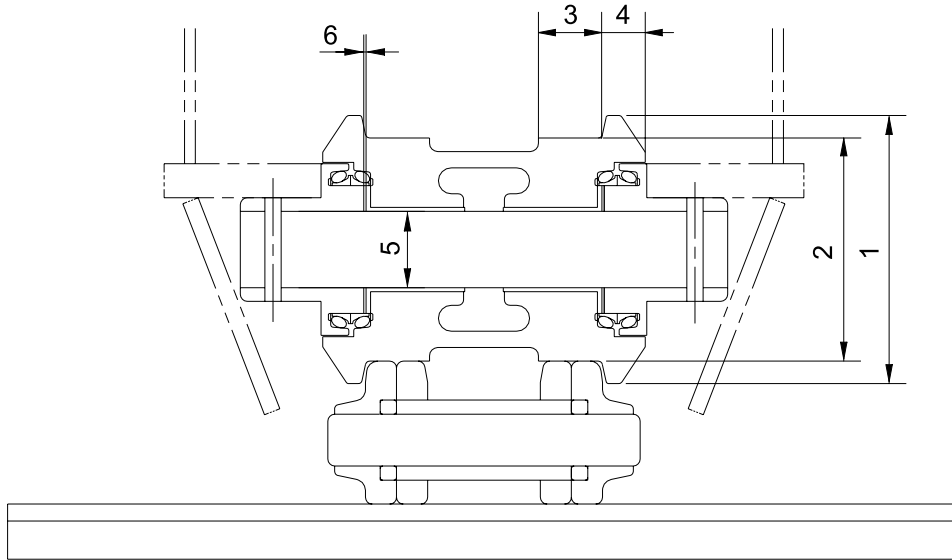

32077MS01

Unit : mm

No.	Check item	Criteria			Remedy
		Standard size		Repair limit	
1	Outside diameter of flange	Standard size		Repair limit	Rebuild or replace
		ø 250		-	
2	Outside diameter of tread	ø 210		ø 198	
3	Width of tread	54.6		60.6	
4	Width of flange	34.4		-	
5	Clearance between shaft and bushing	Standard size & tolerance		Standard clearance	Clearance limit
		Shaft	Hole		
		ø 85 -0.25 -0.35	ø 85 +0.176 +0.029	0.279 to 0.526	2.0
6	Side clearance of roller (both side)	Standard clearance		Clearance limit	
		0.12~1.3		2.0	

2) CARRIER ROLLER

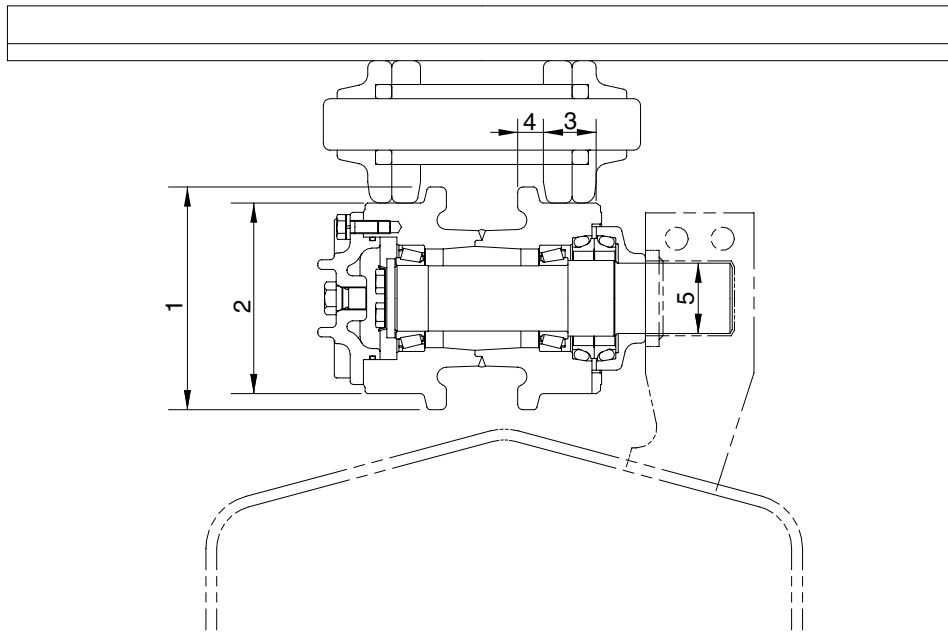

4507AMS04

Unit : mm

No.	Check item	Criteria				Remedy
		Standard size		Repair limit		
1	Outside diameter of flange	ø 220		-		Rebuild or replace
2	Outside diameter of tread	ø 191		ø 181		
3	Width of tread	51		56		
4	Width of flange	20		-		
5	Clearance between shaft and support	Standard size & tolerance		Standard clearance	Clearance limit	Replace
		Shaft	Hole			
		ø 57.15 _{-0.1} ⁰	ø 57.15 _{+0.1} ^{+0.3}	0.1 to 0.4	1.2	

3) IDLER

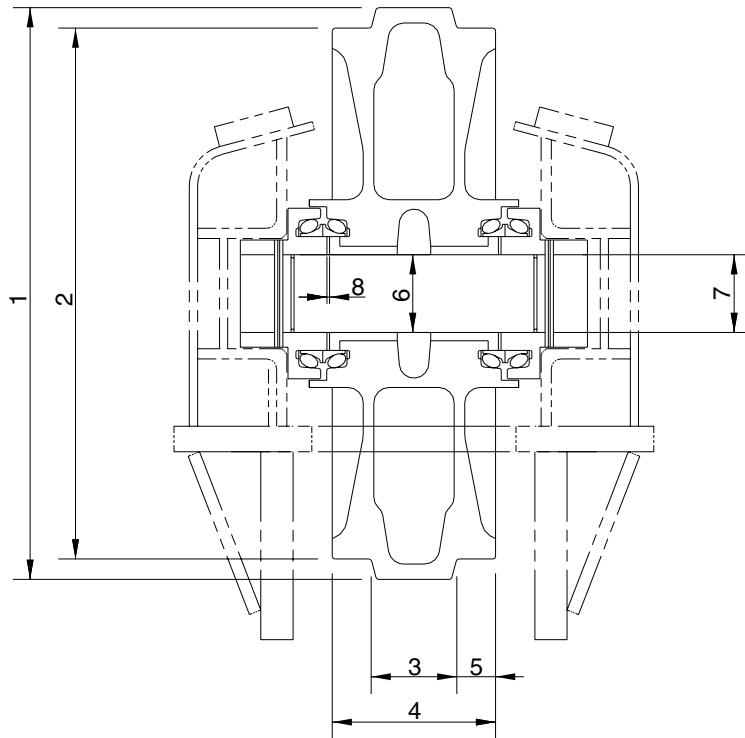

4707AMS03

Unit : mm

No.	Check item	Criteria		Remedy		
		Standard size	Repair limit			
1	Outside diameter of protrusion	∅ 682	-	Rebuild or replace		
2	Outside diameter of tread	∅ 630	∅ 616			
3	Width of protrusion	102	-			
4	Total width	203	-			
5	Width of tread	50.5	57.5			
6	Clearance between shaft and support	Standard size & tolerance		Standard clearance	Clearance limit	Replace bushing
		Shaft	Hole			
		∅ 85 $\begin{matrix} 0 \\ -0.035 \end{matrix}$	∅ 85.35 $\begin{matrix} +0.05 \\ 0 \end{matrix}$	0.35 to 0.435	2.0	
7	Clearance between shaft and support	∅ 85 $\begin{matrix} 0 \\ -0.035 \end{matrix}$	∅ 85 $\begin{matrix} +0.09 \\ +0.036 \end{matrix}$	0.036 to 0.125	1.2	Replace
8	Side clearance of idler (Both side)	Standard clearance		Clearance limit		Replace
		0.25 to 1.2		2.0		

4) TRACK

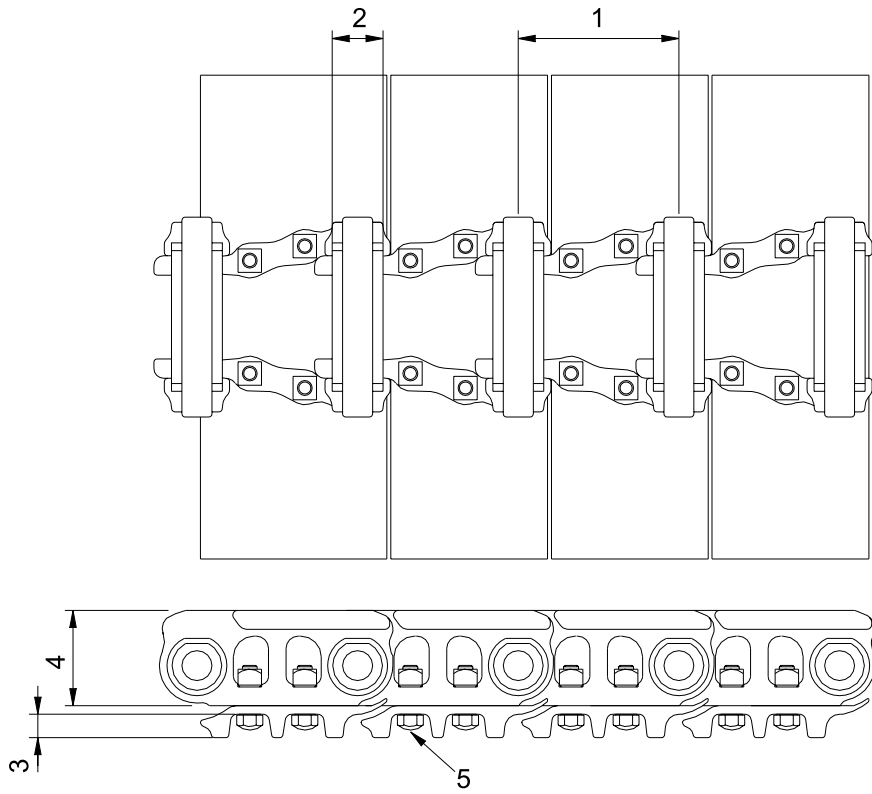

32077MS04

Unit : mm

No.	Check item	Criteria		Remedy
		Standard size	Repair limit	
1	Link pitch	215.9	226.7	Turn or replace
2	Outside diameter of bushing	∅ 71	∅ 60.4	Rebuild or replace
3	Height of grouser	36	21	
4	Height of link	129	115	Retighten
5	Tightening torque	Initial tightening torque : 105 ± 5 kgf · m		

5) TRACK FRAME AND RECOIL SPRING

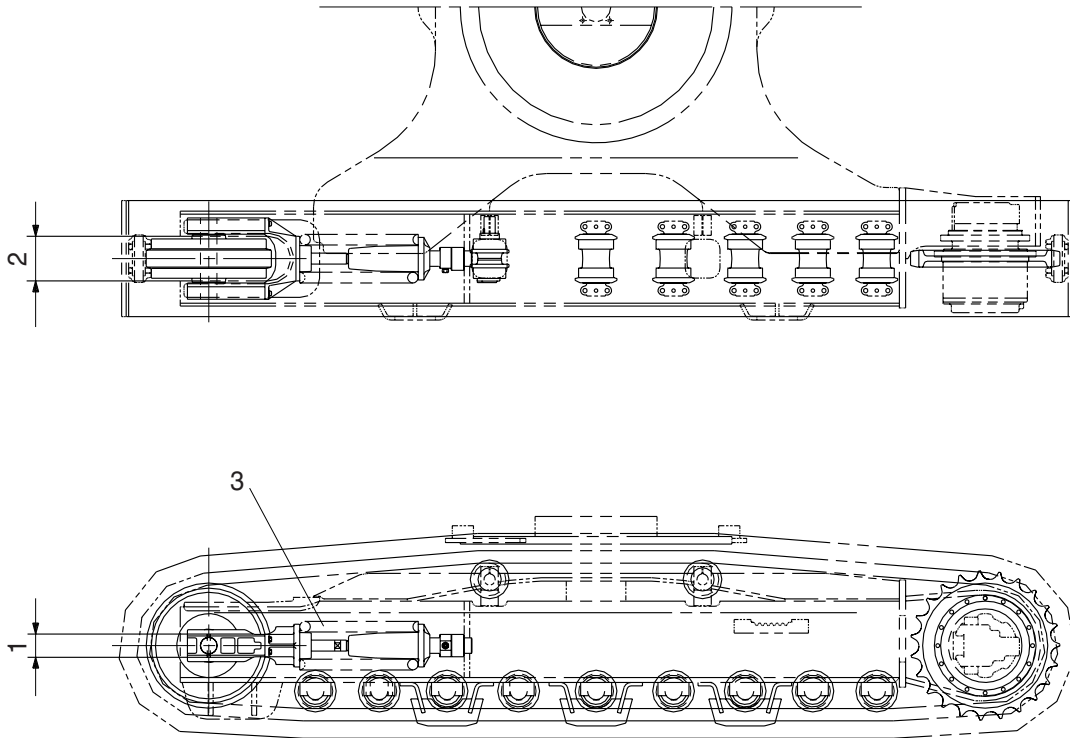

21073MS05

Unit : mm

No.	Check item	Criteria				Remedy	
			Standard size	Tolerance	Repair limit		
1	Vertical width of idler guide	Track frame	123	+2 -1	137	Rebuild or replace	
		Idler support	120	0 -1.5	116		
2	Horizontal width of idler guide	Track frame	292	+2 -1	296		
		Idler support	290	-	287		
3	Recoil spring	Standard size		Repair limit		Replace	
		Free length	Installation length	Installation load	Free length		Installation load
		∅ 254 × 740	595	24500 kg	-		19600 kg

2. WORK EQUIPMENT

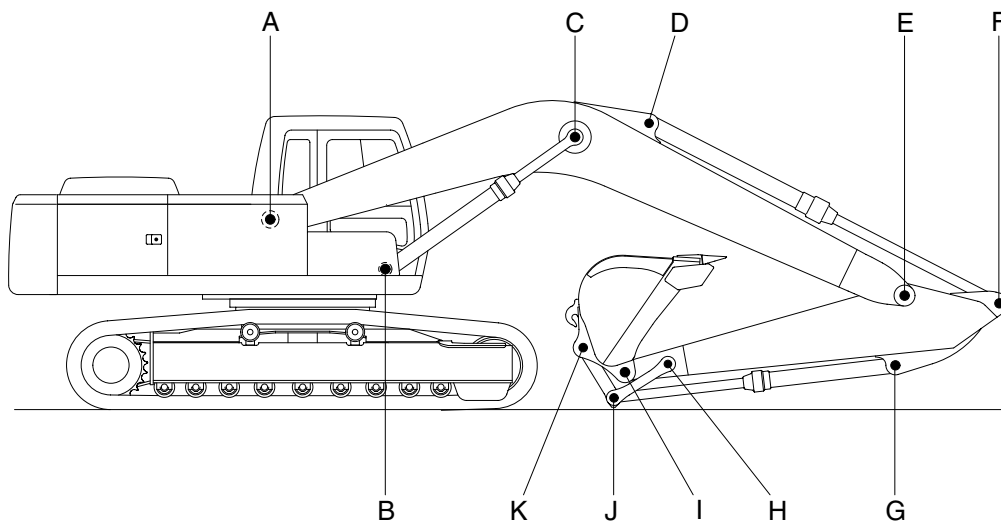

21077MS20

Unit : mm

Mark	Measuring point (Pin and Bushing)	Normal value	Pin		Bushing		Remedy & Remark
			Recomm. service limit	Limit of use	Recomm. service limit	Limit of use	
A	Boom Rear	120	119	118.5	120.5	121	Replacement
B	Boom Cylinder Head	100	99	98.5	100.5	101	
C	Boom Cylinder Rod	110	109	108.5	110.5	111	
D	Arm Cylinder Head	110	109	108.5	110.5	111	
E	Boom Front	110	109	108.5	110.5	111	
F	Arm Cylinder Rod	110	109	108.5	110.5	111	
G	Bucket Cylinder Head	90	89	88.5	90.5	91	
H	Arm Link	90	89	88.5	90.5	91	
I	Bucket and Arm Link	100	99	98.5	100.5	101	
J	Bucket Cylinder Rod	90	89	88.5	90.5	91	
K	Bucket Link	100	99	98.5	100.5	101	