

# GROUP 4 SINGLE OPERATION

## 1. BOOM UP OPERATION

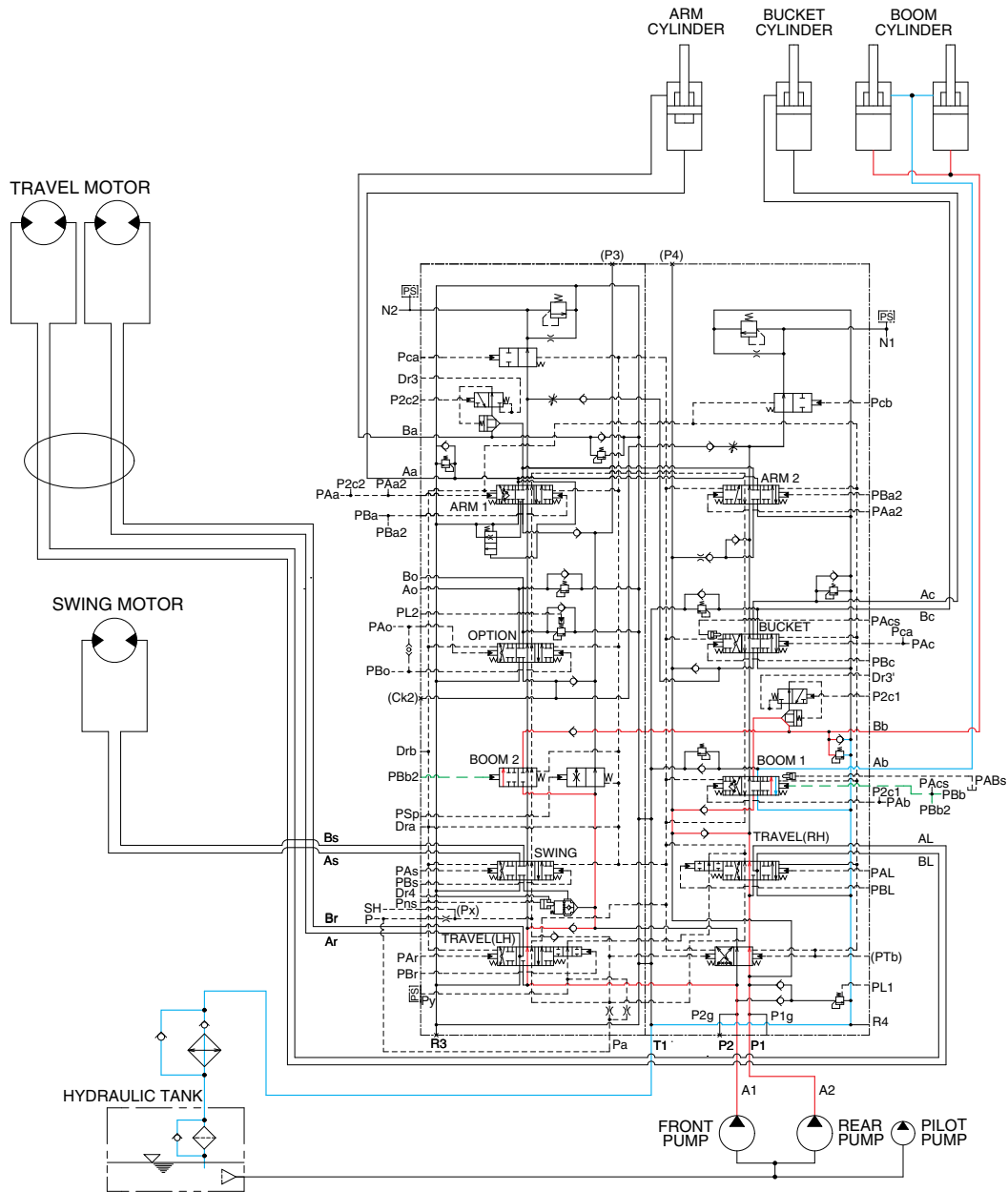

43093HC10

When the RH control lever is pulled back, the boom spools in the main control valve are moved to the up position by the pilot oil pressure from the remote control valve.

The oil from the front and rear pump flows into the main control valve and then goes to the large chamber of boom cylinders.

At the same time, the oil from the small chamber of boom cylinders returns to the hydraulic oil tank through the boom spool in the main control valve. When this happens, the boom goes up.

The excessive pressure in the boom cylinder bottom end circuit is prevented by relief valve.

When the boom is up and the control lever is returned to neutral position, the circuit for the holding pressure at the bottom end of the boom cylinder is closed by the boom holding valve.

This prevents the hydraulic drift of boom cylinder.

## 2. BOOM DOWN OPERATION

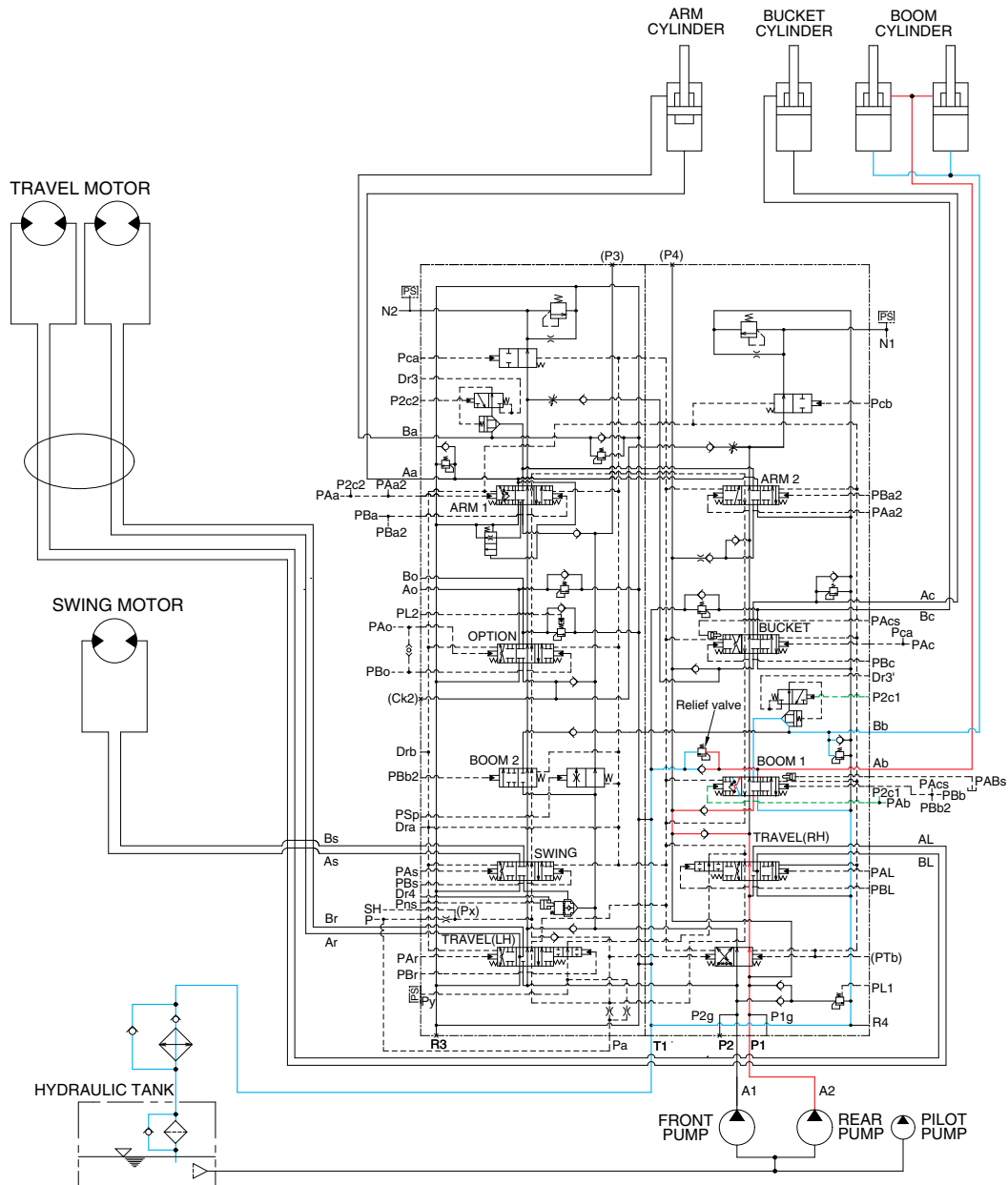

43093HC11

When the RH control lever is pushed forward, the boom 1 spools in the main control valve are moved to the down position by the pilot oil pressure from the remote control valve.

The oil from the rear pump flows into the main control valve and then goes to the small chamber of boom cylinders. At the same time, the oil from the large chamber of boom cylinders returns to the hydraulic tank through the boom 1 spool in the main control valve.

When the down speed of boom is faster, the oil returned from the large chamber of boom cylinder combines with the oil from the rear pump, and flows into the small chamber of the boom cylinder.

This prevents cylinder cavitation by the negative pressure when the rear pump flow can not match the boom down speed. And the excessive pressure in the boom cylinder rod end circuit is prevented by the relief valve.

### 3. ARM IN OPERATION

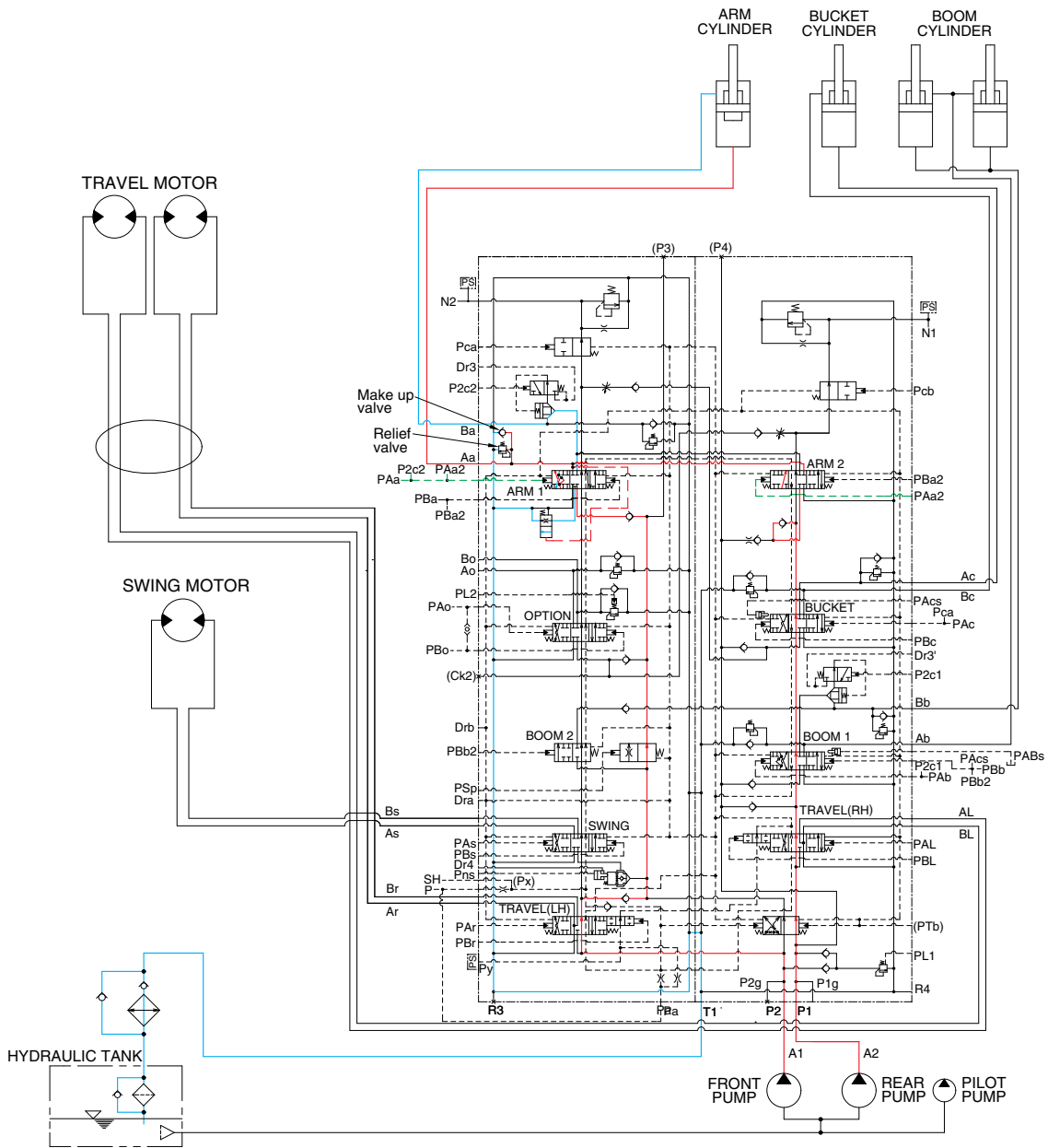

43093HC12

When the LH control lever is pulled back, the arm spools in the main control valve are moved to the roll in position by the pilot oil pressure from the remote control valve.

The oil from the front and rear pump flows into the main control valve and then goes to the large chamber of the arm cylinder.

At the same time, the oil from the small chamber of the arm cylinder returns to the hydraulic oil tank through the arm spool in the main control valve. When this happens, the arm rolls in.

The excessive pressure in the arm cylinder head side is prevented by the relief valve.

The cavitation which will happen to the head side of the arm cylinder is also prevented by the make-up valve in the main control valve.

## 4. ARM OUT OPERATION

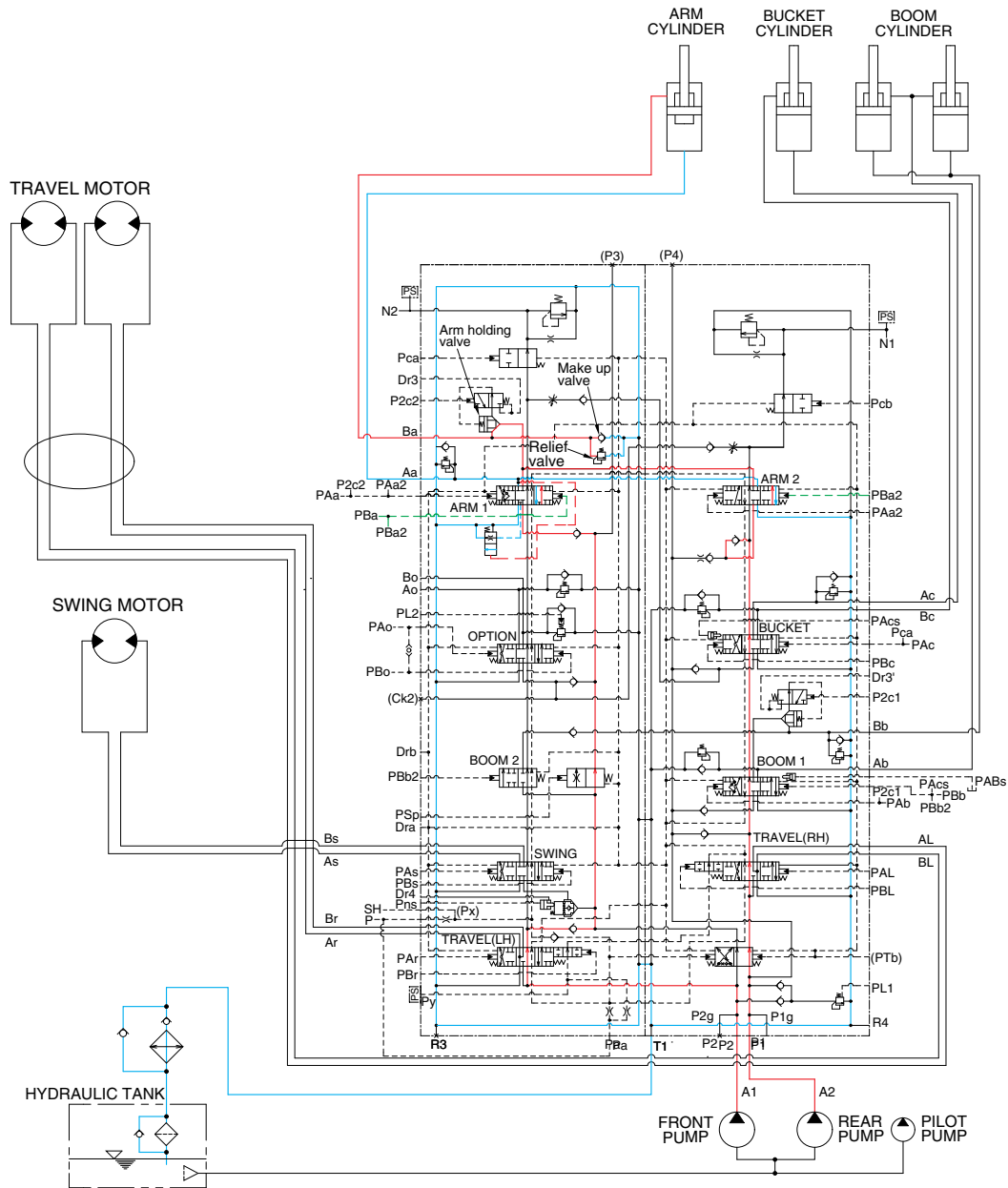

43093HC13

When the LH control lever is pushed forward, the arm spools in the main control valve are moved to the roll out position by the pilot oil pressure from the remote control valve.

The oil from the front and rear pump flows into the main control valve and then goes to the small chamber of arm cylinder.

At the same time, the oil from the large chamber of arm cylinder returns to the hydraulic oil tank through the arm spools in the main control valve. When this happens, the arm rolls out.

The excessive pressure in the arm cylinder rod side is prevented by relief valve.

When the arm is roll out and the control lever is returned to neutral position, the circuit for the holding pressure at the rod side of the arm cylinder is closed by the arm holding valve.

The cavitation which will happen to the rod side of the arm cylinder is also prevented by the make-up valve in the main control valve.

## 5. BUCKET IN OPERATION

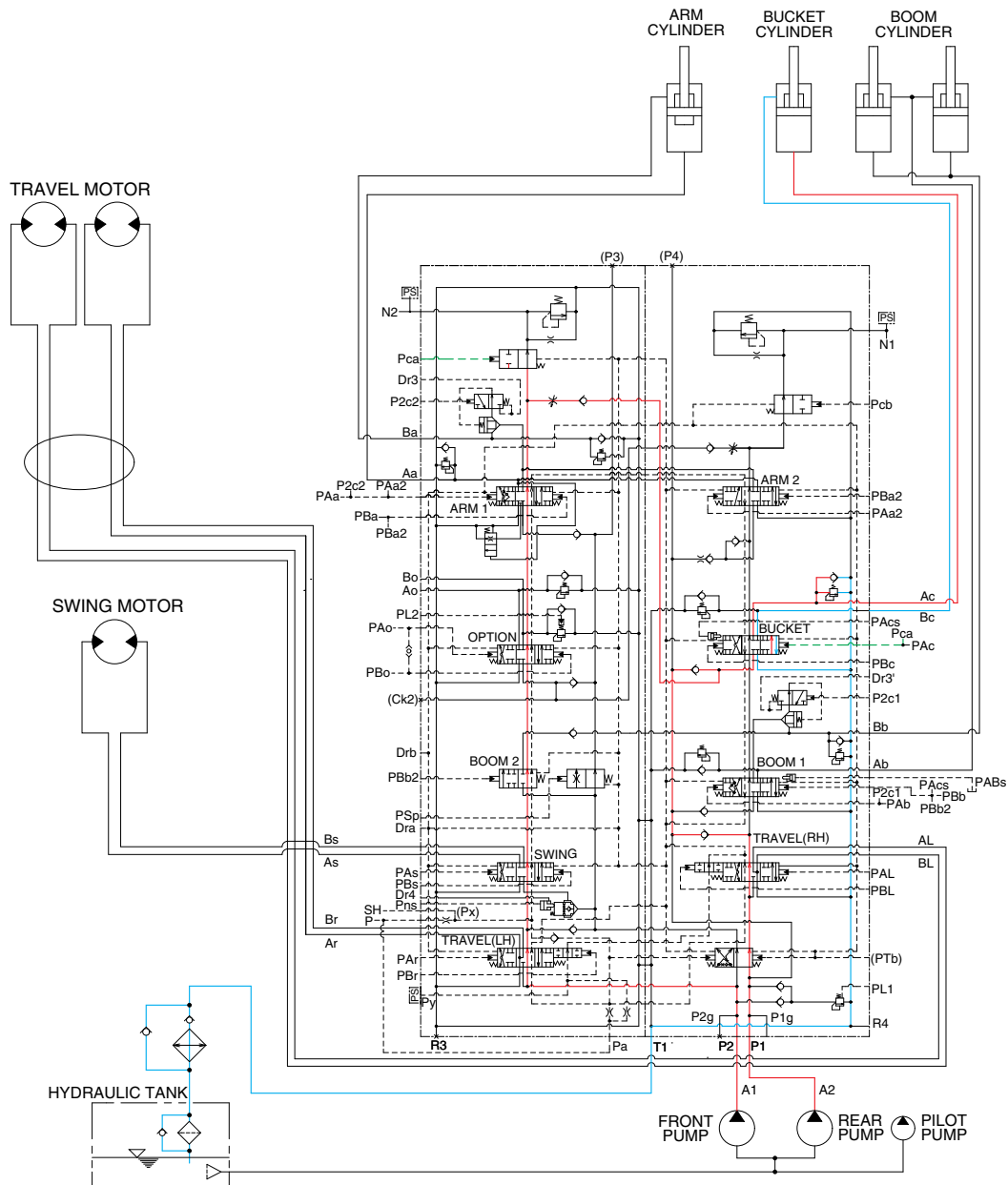

43093HC14

When the RH control lever is pulled left, the bucket spool in the main control valve is moved to the roll in position by the pilot oil pressure from the remote control valve.

The oil from the rear pump flows into the main control valve and then goes to the large chamber of bucket cylinder. The oil from the front pump flows into the large chamber of bucket cylinder through confluence oil passage in the main control valve by bypass cut pilot pressure (Pca).

At the same time, the oil from the small chamber of bucket cylinder returns to the hydraulic oil tank through the boom spool in the main control valve. When this happens, the bucket rolls in.

The excessive pressure in the bucket cylinder head side is prevented by relief valve.

The cavitation which will happen to the head side of the bucket cylinder is also prevented by the make-up valve in the main control valve.

## 6. BUCKET OUT OPERATION

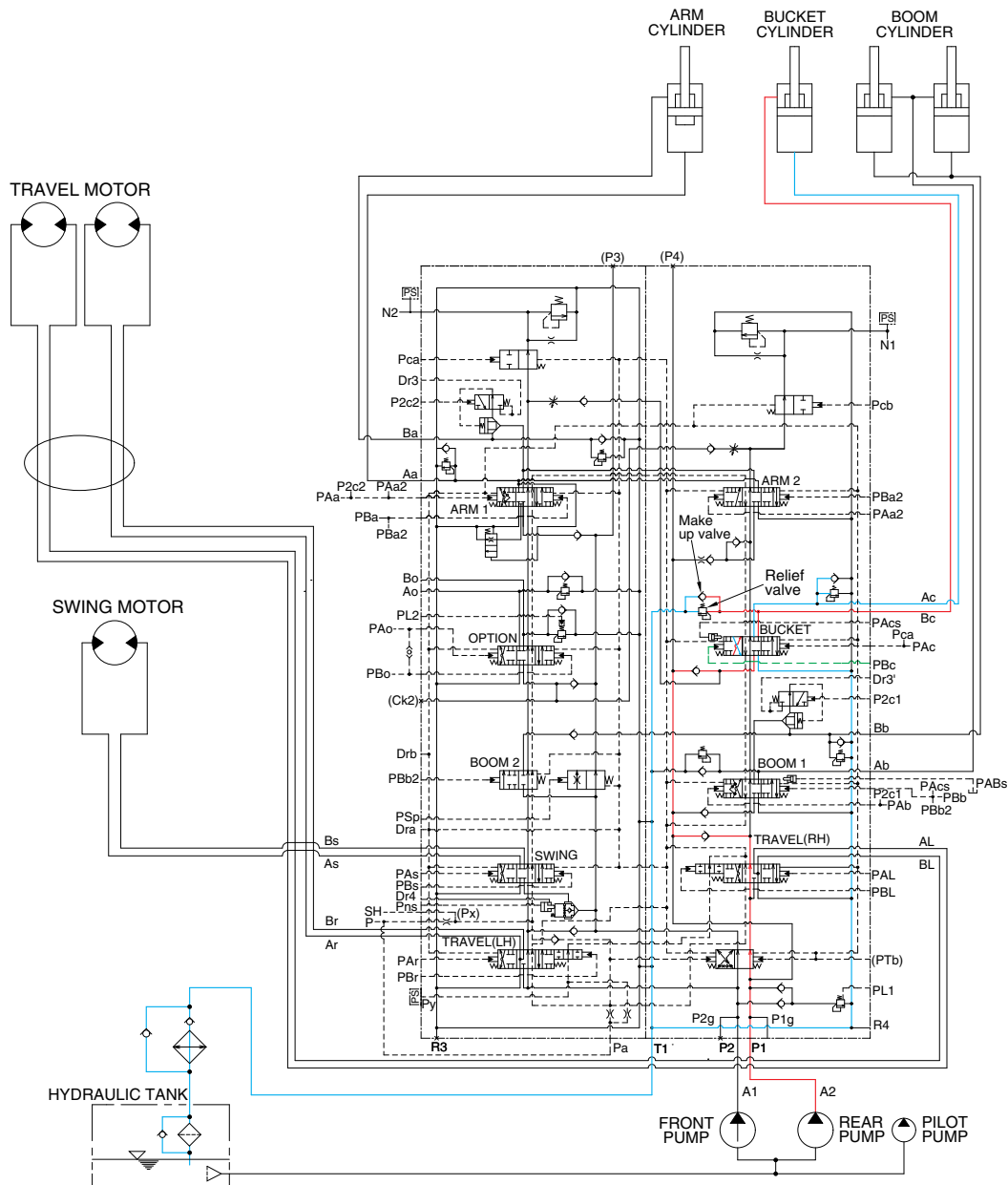

43093HC15

When the RH control lever is pushed right, the bucket spool in the main control valve is moved to the roll out position by the pilot oil pressure from the remote control valve.

The oil from the rear pump flows into the main control valve and then goes to the small chamber of bucket cylinder.

At the same time, the oil from the large chamber of bucket cylinder returns to the hydraulic oil tank through the bucket spool in the main control valve. When this happens, the bucket rolls out.

The excessive pressure in the bucket cylinder rod side is prevented by relief valve.

The cavitation which will happen to the rod side of the bucket cylinder is also prevented by the make-up valve in the main control valve.

## 7. SWING OPERATION

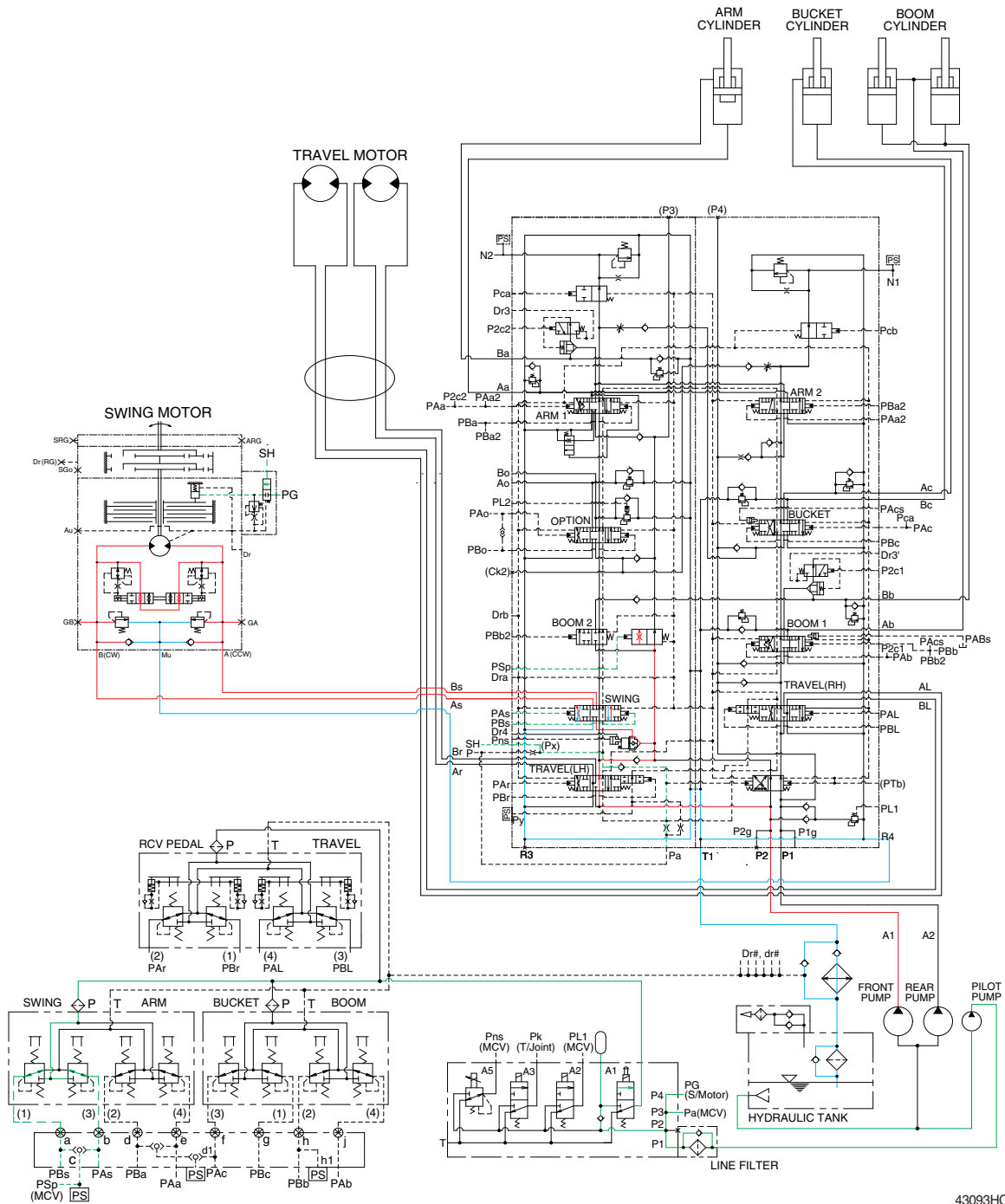

43093HC16

When the LH control lever is pushed left or right, the swing spool in the main control valve is moved to the left or right swing position by the pilot oil pressure from the remote control valve.

Also the swing operation preference function is operated by the pilot pressure Psp (refer to page 2-35).

The oil from the front pump flows into the main control valve and then goes to the swing motor.

At the same time, the return oil from the swing motor returns to the hydraulic oil tank through the swing spool in the main control valve.

When this happens, the upper structure swings to the left or right.

The swing parking brake, make up valve and the motor brake valve are provided in the swing motor.

The cavitation which will happen to the swing motor is also prevented by the make up valve in the swing motor itself.

## SWING CIRCUIT OPERATION

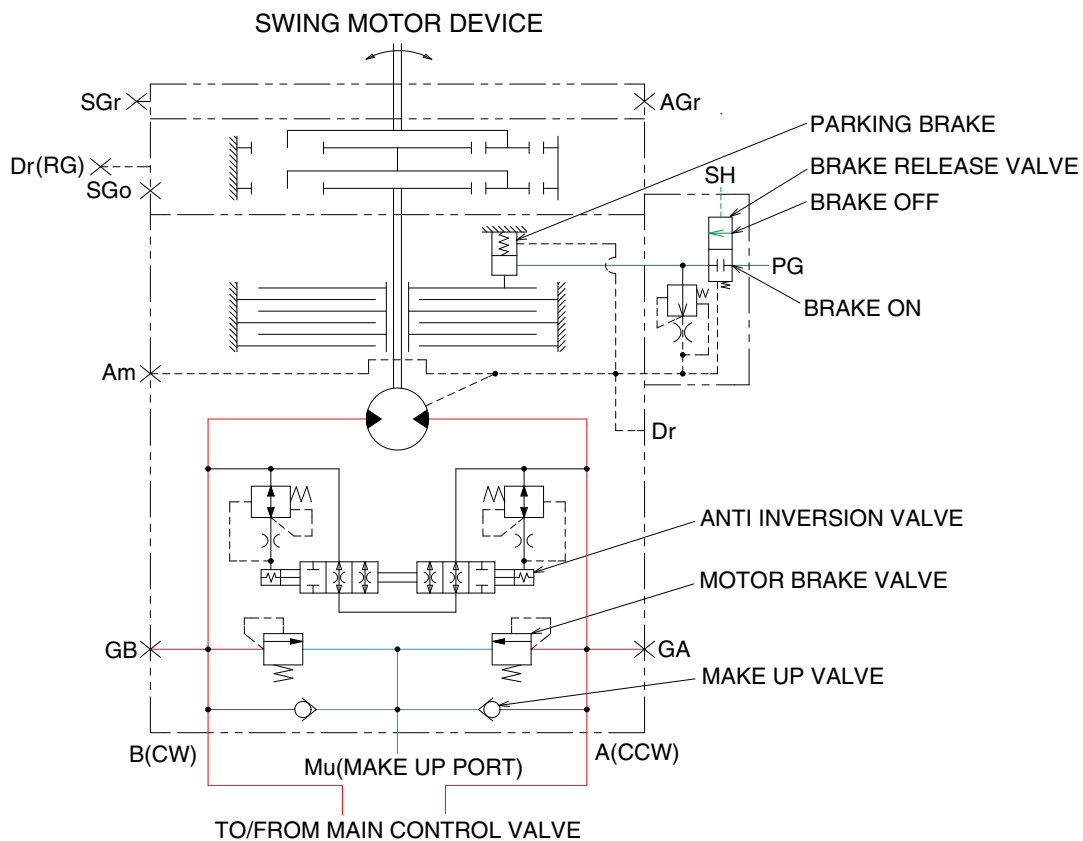

### 1) MOTOR BRAKE VALVE

Motor brake valve for the swing motor limits to cushion the starting and stopping pressure of swing operation and controls the swing motor operating pressure.

### 2) MAKE UP VALVE

The make up valves prevent cavitation by supplying return oil to the vacuum side of the motor.

### 3) PARKING BRAKE

This is function as a parking brake only when all of the RCV lever (except travel pedal) are not operated.

#### PARKING BRAKE "OFF" OPERATION

The parking brake is released by the pilot pressure oil from the pilot pump.

When the RCV lever placed in the operating position, the pilot oil flows into SH port through the MCV. This pressure transferred to the brake release valve and the brake release valve is change over. Then the pilot oil pressure PG lift the brake piston and release the parking brake.

#### PARKING BRAKE "ON" OPERATION

When all of the RCV lever placed in the neutral position, the pressure of the pilot oil passage down. Then the brake release valve returned to the neutral position and the oil is returned from the brake piston to the tank. And the brake is set to 'ON'.

### 4) ANTI-INVERSION VALVE

This anti-inversion valve absorbs shocks produced as swing motion stops and reduced oscillation cause by swing motion.



## 8. TRAVEL FORWARD AND REVERSE OPERATION

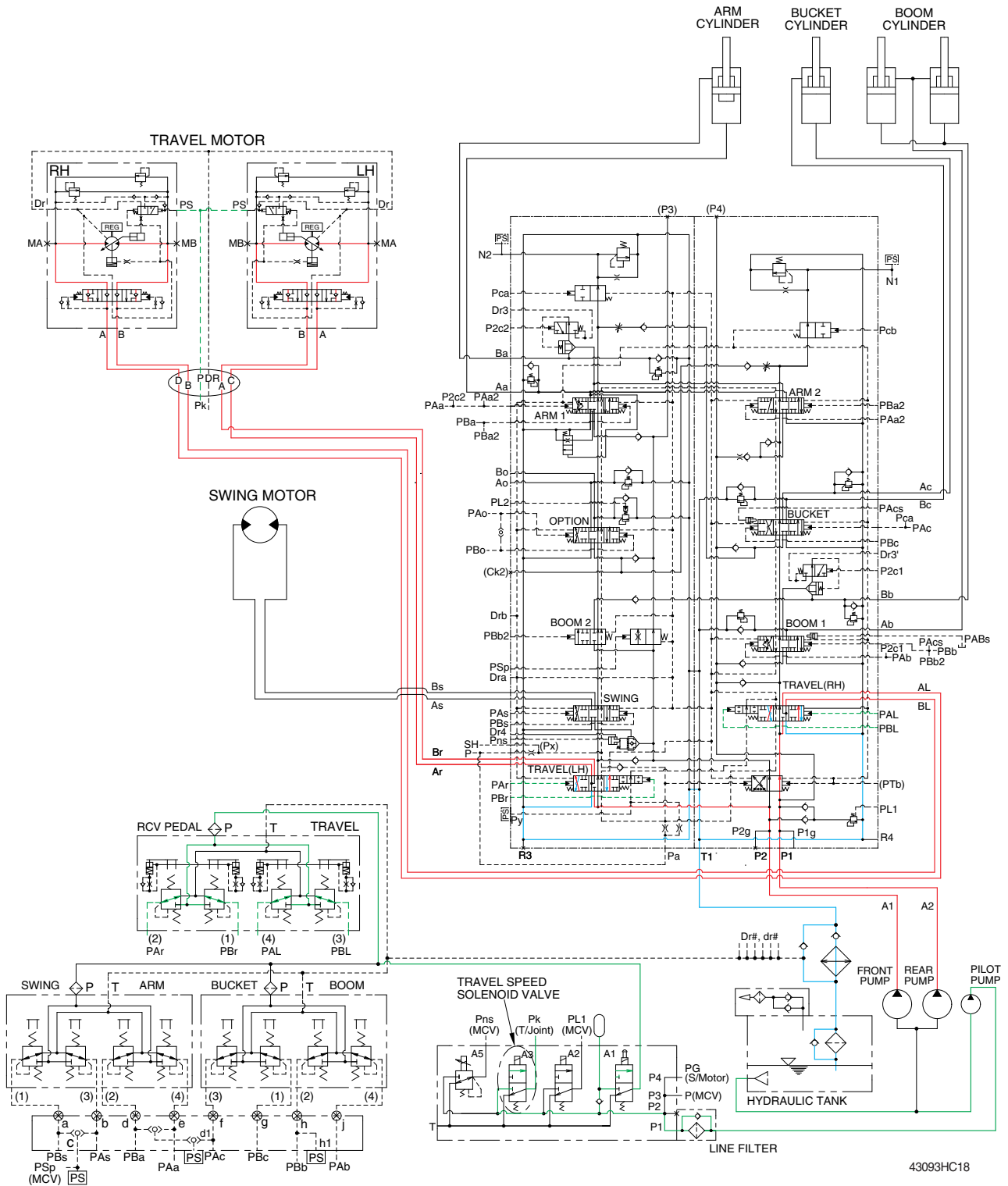

43093HC18

When the travel levers are pushed forward or reverse position, the travel spools in the main control valve are moved to the forward or reverse travel position by the pilot oil pressure from the remote control valve.

The oil from the each pump flows into the main control valve and then goes to the each travel motor through the turning joint.

The return oil from both travel motors returns to the hydraulic oil tank through the turning joint and the travel spools in the main control valve.

When this happens, the machine moves to the forward or reverse.

## TRAVEL CIRCUIT OPERATION

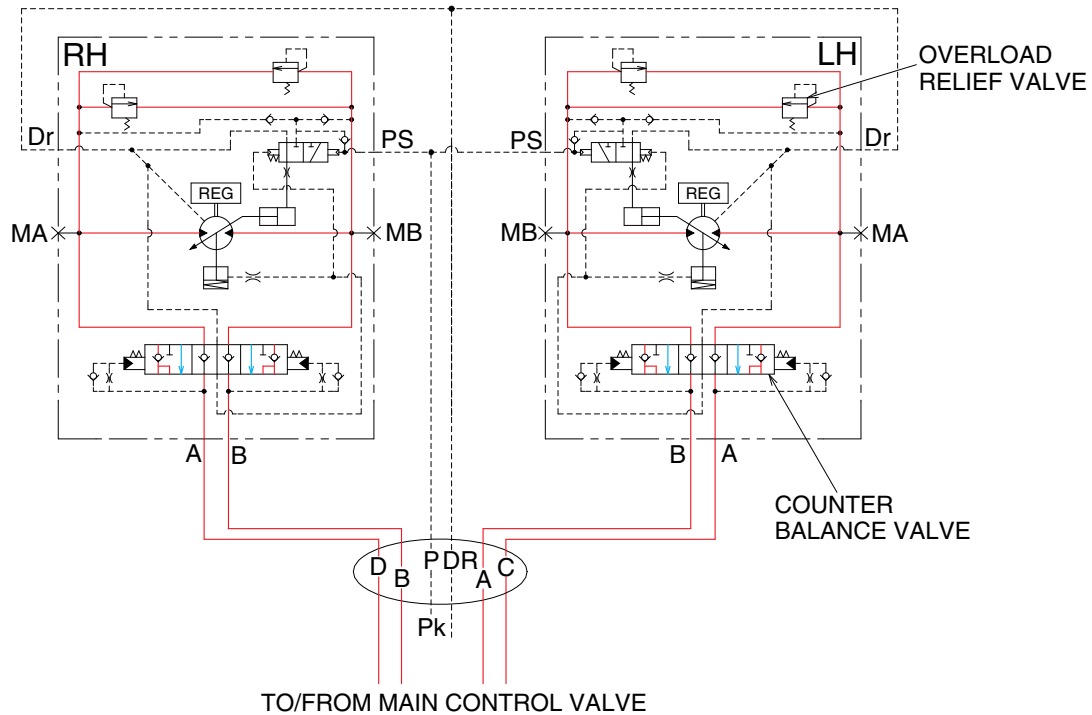

43093HC19

Valves are provided on travel motors to offer the following functions.

### 1) COUNTER BALANCE VALVE

When stopping the motor of slope descending, this valve to prevent the motor over run.

### 2) OVERLOAD RELIEF VALVE

Relief valve limit the circuit pressure below 360 kgf/cm<sup>2</sup> to prevent high pressure generated at a time of stopping the machine. Stopping the motor, this valve sucks the oil from lower pressure passage for preventing the negative pressure and the cavitation of the motor.