

SECTION 4 ELECTRICAL SYSTEM

Group 1 Component Location	4-1
Group 2 Electrical Circuit	4-3
Group 3 Electrical Component Specification	4-21
Group 4 Connectors	4-29

SECTION 4 ELECTRICAL SYSTEM

GROUP 1 COMPONENT LOCATION

1. LOCATION 1

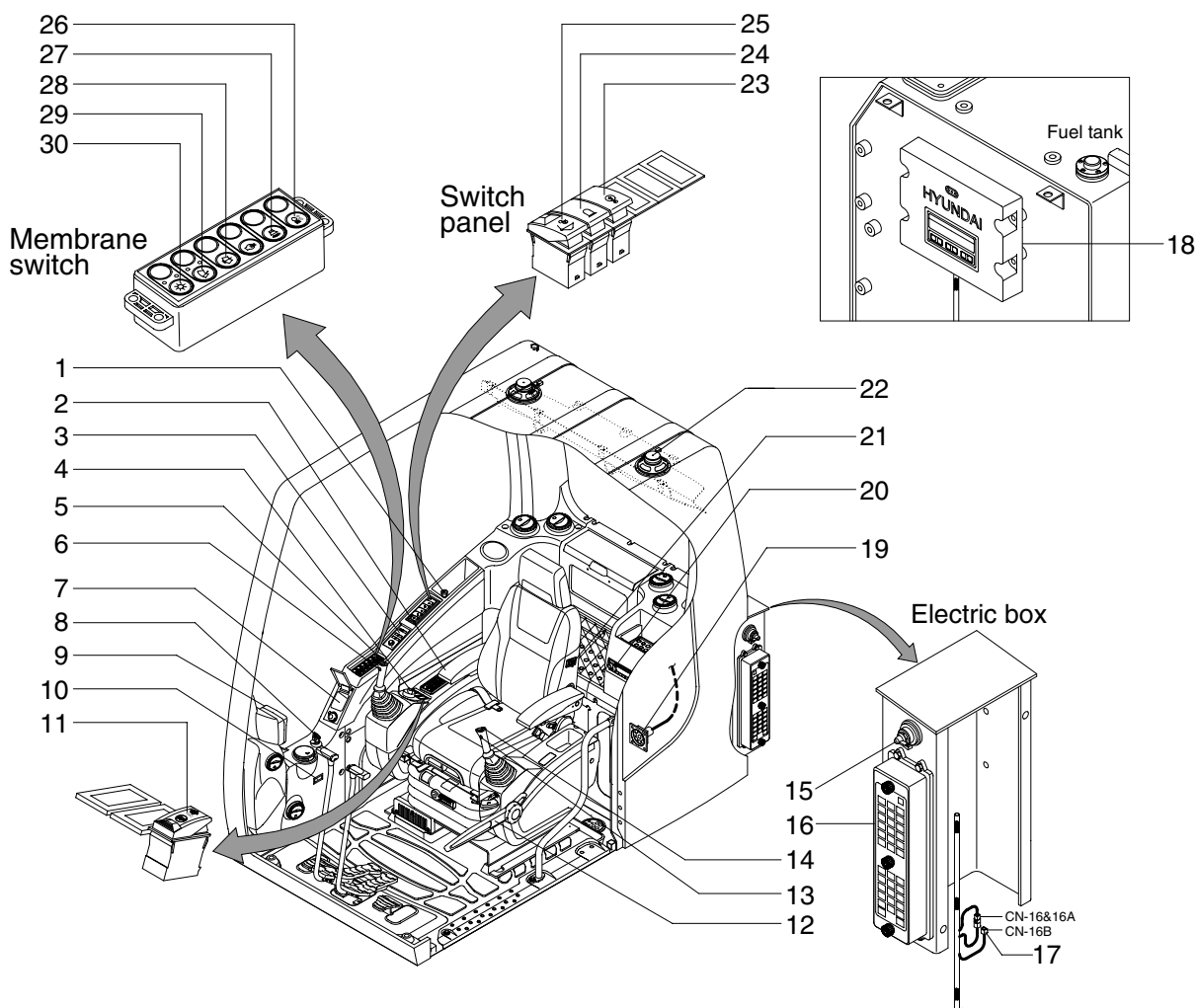

43094EL01

- | | | |
|--------------------------------|---------------------------------|------------------------|
| 1 Cigar light | 11 Air compressor switch | 21 Heated seat switch |
| 2 Aircon & heater switch panel | 12 Safety lever | 22 Speaker |
| 3 Remote controller | 13 Power max switch | 23 Overload switch |
| 4 Accel dial switch | 14 One touch decel switch | 24 Beacon switch |
| 5 Horn switch | 15 Fuse box | 25 Quick clamp switch |
| 6 Breaker operation switch | 16 Master switch | 26 Cab light switch |
| 7 Handsfree | 17 Emergency engine connector | 27 Travel alarm switch |
| 8 Cluster | 18 MCU | 28 Washer switch |
| 9 Starting switch | 19 RS232 & J1939 service socket | 29 Wiper switch |
| 10 Service meter | 20 Radio & USB player | 30 Main light switch |

2. LOCATION 2

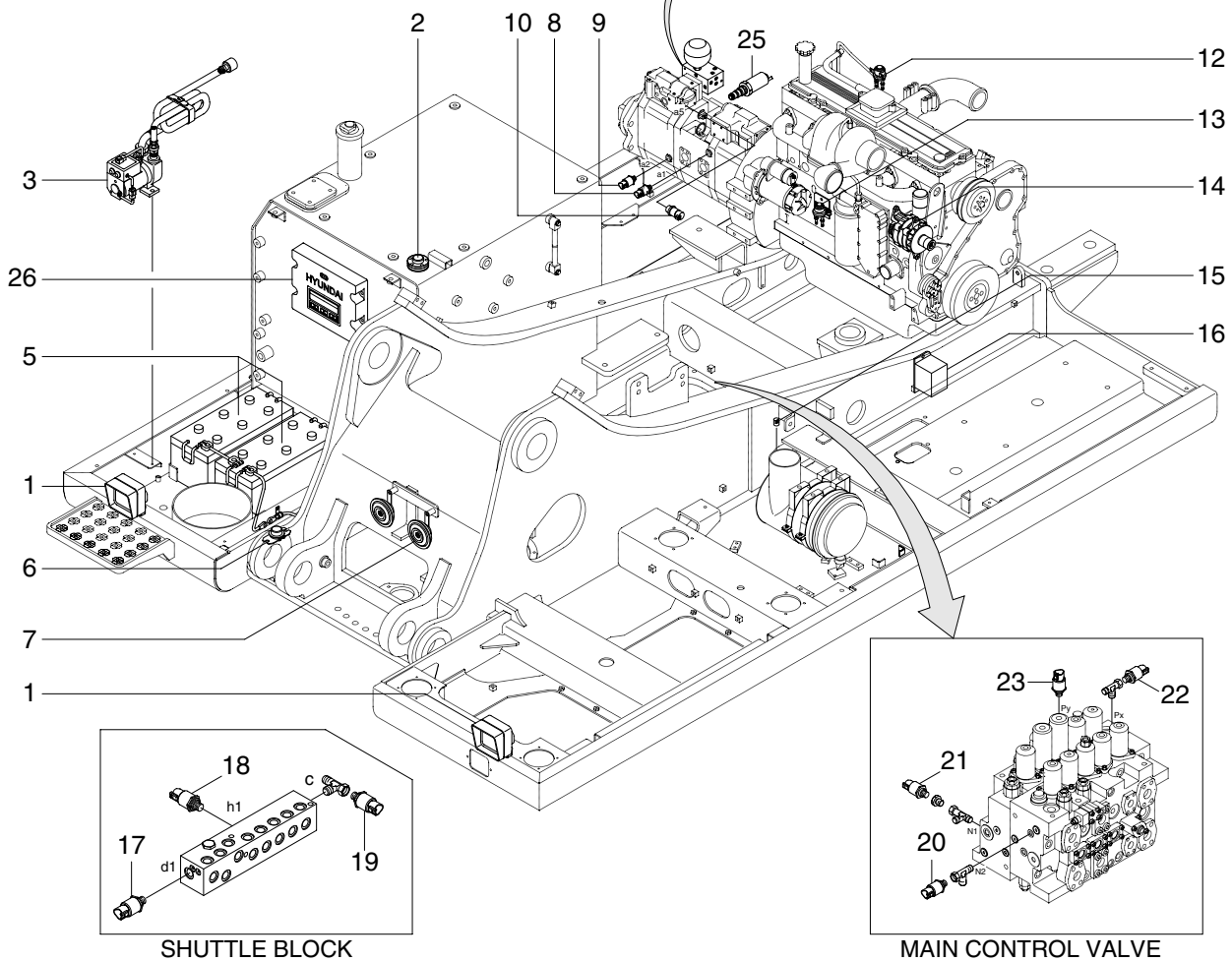
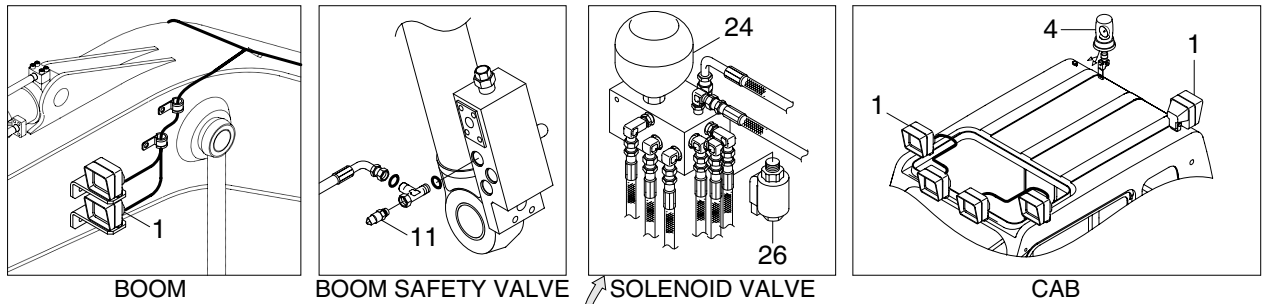

43094EL02

- | | | | | | |
|---|--------------------|----|---------------------------------|----|--------------------------------|
| 1 | Lamp | 10 | P3 pressure sensor | 19 | Swing pressure sensor |
| 2 | Fuel sender | 11 | Overload pressure sensor | 20 | Nega control 1 pressure sensor |
| 3 | Fuel filler pump | 12 | Heater relay | 21 | Nega control 2 pressure sensor |
| 4 | Beacon lamp | 13 | Start relay | 22 | Attach pressure sensor |
| 5 | Battery | 14 | Alternator | 23 | Travel pressure sensor |
| 6 | Battery relay | 15 | Air cleaner switch | 24 | Solenoid valve |
| 7 | Horn | 16 | Travel alarm buzzer | 25 | Pump EPPR valve |
| 8 | P1 pressure sensor | 17 | Arm / bucket in pressure sensor | 26 | Boom priority EPPR valve |
| 9 | P2 pressure sensor | 18 | Boom up pressure sensor | | |