

GROUP 4 MAIN CONTROL VALVE

1. REMOVAL AND INSTALL

1) REMOVAL

- (1) Lower the work equipment to the ground and stop the engine.
- (2) Operate the control levers and pedals several times to release the remaining pressure in the hydraulic piping.
- (3) Loosen the breather slowly to release the pressure inside the hydraulic tank.

▲ Escaping fluid under pressure can penetrate the skin causing serious injury.

※ When pipes and hoses are disconnected, the oil inside the piping will flow out, so catch it in oil pan.

- (4) Remove bolts and disconnect pipes.
- (5) Disconnect pilot line hoses.
- (6) Disconnect pilot pipes.
- (7) Sling the control valve assembly and remove the control valve mounting bolts.
· Weight : 340 kg (750 lb)
- (8) Remove the control valve assembly.
When removing the control valve assembly, check that all the piping have been disconnected.

2) INSTALL

- (1) Carry out installation in the reverse order to removal.
- (2) Bleed the air from below items.
 - ① Cylinder (Boom, arm, bucket)
 - ② Swing motor
 - ③ Travel motor※ See each item removal and install.
- (3) Confirm the hydraulic oil level and recheck the hydraulic oil leak or not.

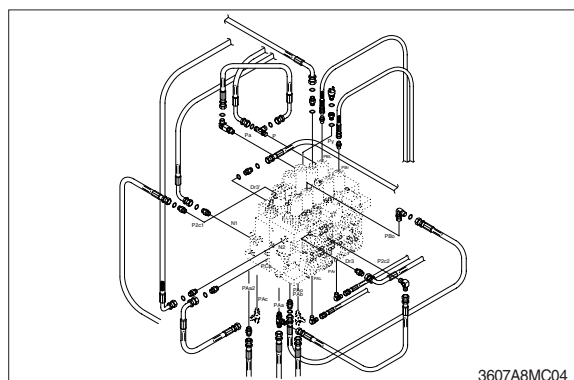
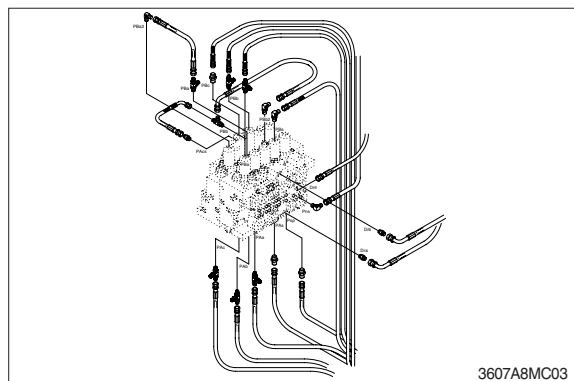
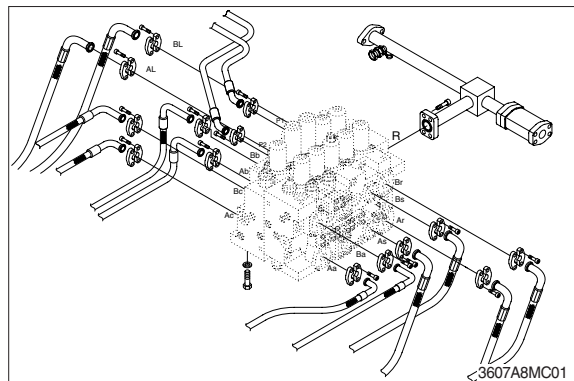

2. STRUCTURE (1/4)

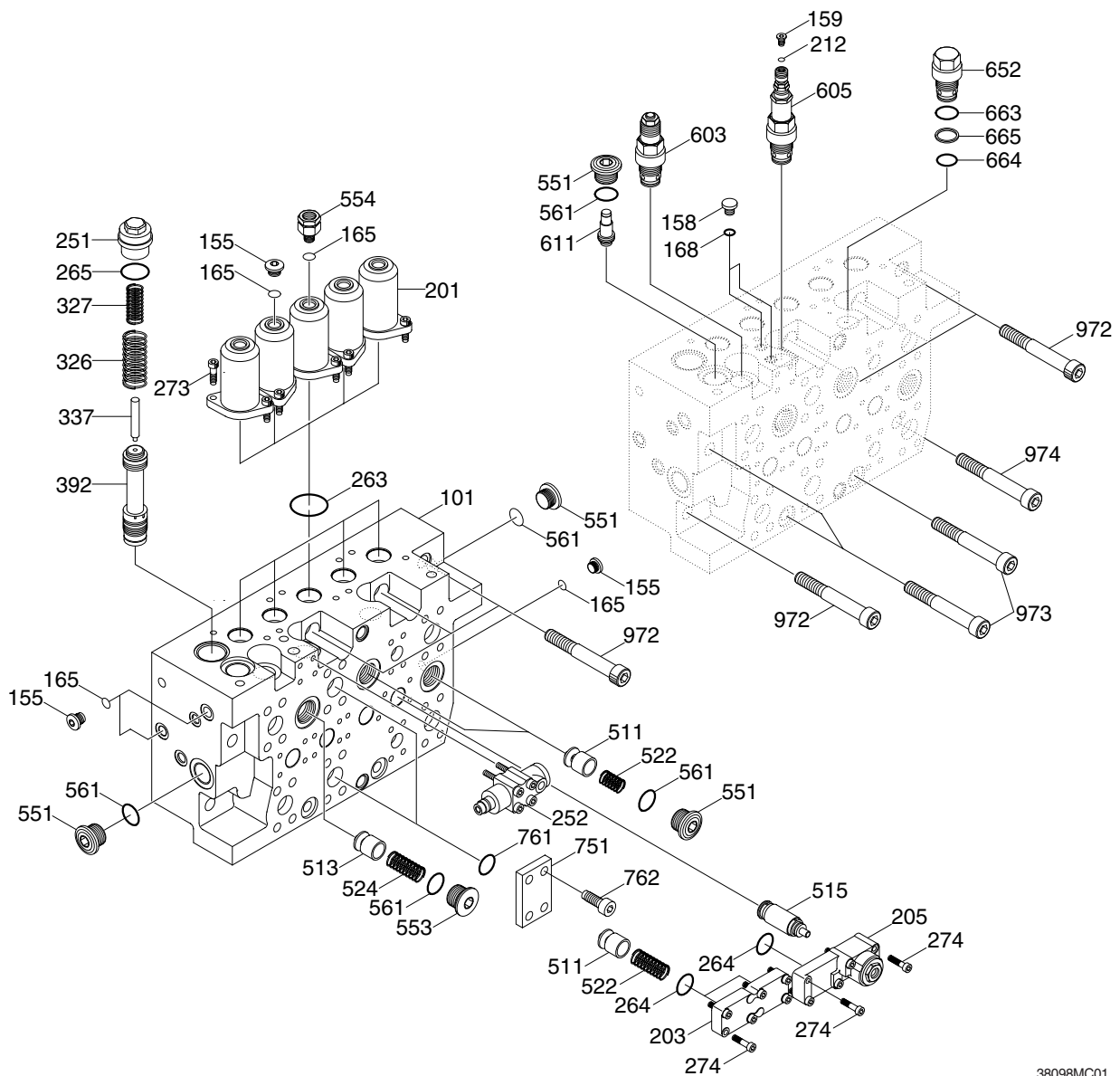

38098MC01

101	Casing A	264	O-ring	561	O-ring
155	Plug	265	O-ring	562	O-ring
158	Plug	274	Socket bolt	603	Port relief assy
159	Plug	326	Spring	605	Port relief assy
161	O-ring	327	Spring	611	Negative relief valve assy
162	O-ring	335	Shim	652	Plug
163	O-ring	337	Rod	663	O-ring
165	O-ring	392	By pass cut spool	664	O-ring
168	O-ring	511	Poppet	665	Back-up ring
201	Spring cover	513	Poppet	751	Flange
203	Spring cover	515	Boom priority valve assy	761	O-ring
205	Cover sub-Bm/Priority	522	Spring	762	Screw
212	O-ring	524	Spring	972	Screw
251	Plug	551	Plug	973	Screw
252	Lock valve assy	553	Plug	974	Screw
263	O-ring	554	Stopper plug		

STRUCTURE (2/4)

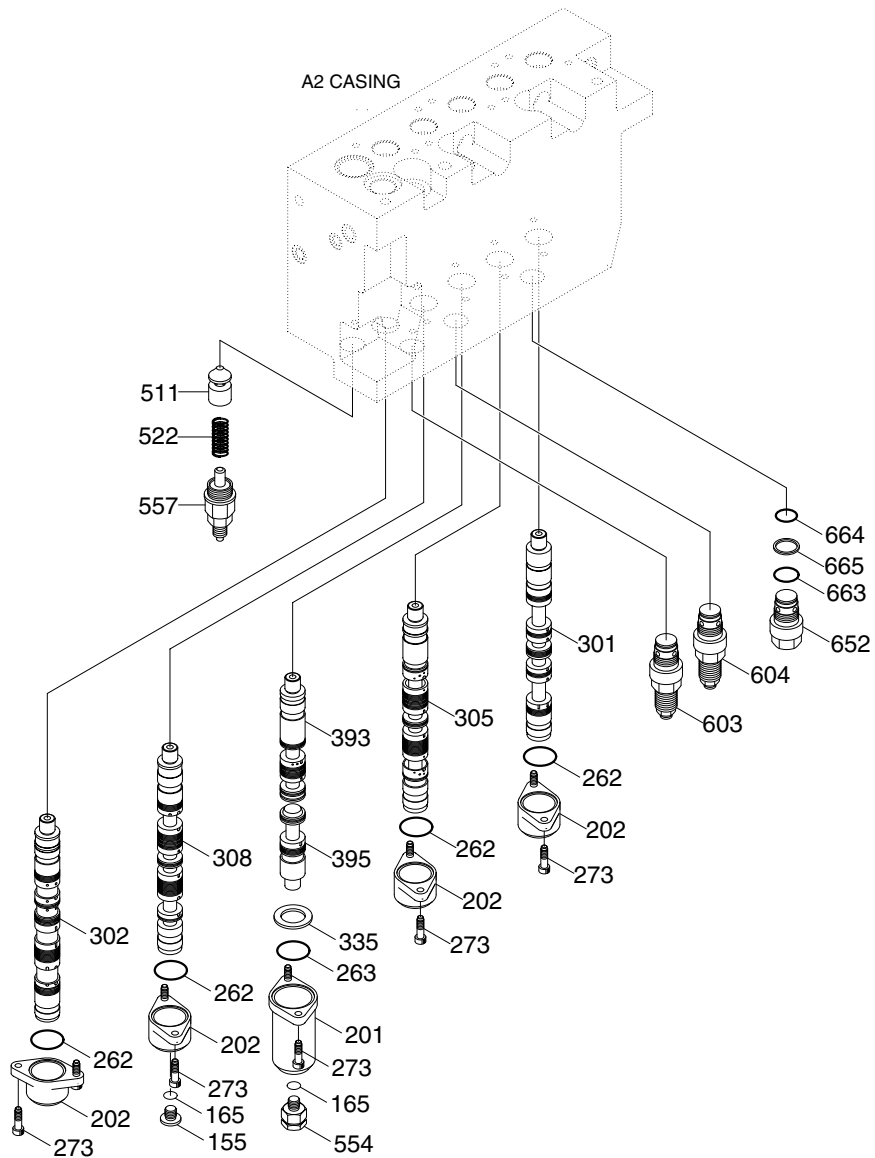

- 155 Plug
- 165 O-ring
- 201 Spring cover
- 202 Spring cover
- 262 O-ring
- 263 O-ring
- 273 Hex screw
- 301 Travel spool kit

- 302 Arm spool kit
- 305 Swing spool kit
- 308 Option spool kit
- 335 Shim
- 393 Boom spool kit
- 395 Swing priority spool kit
- 511 Poppet
- 522 Spring

- 554 Stopper plug
- 557 Plug
- 603 Port relief assy
- 652 Plug
- 663 O-ring
- 664 O-ring
- 665 Back-up ring

38098MC02

STRUCTURE (3/4)

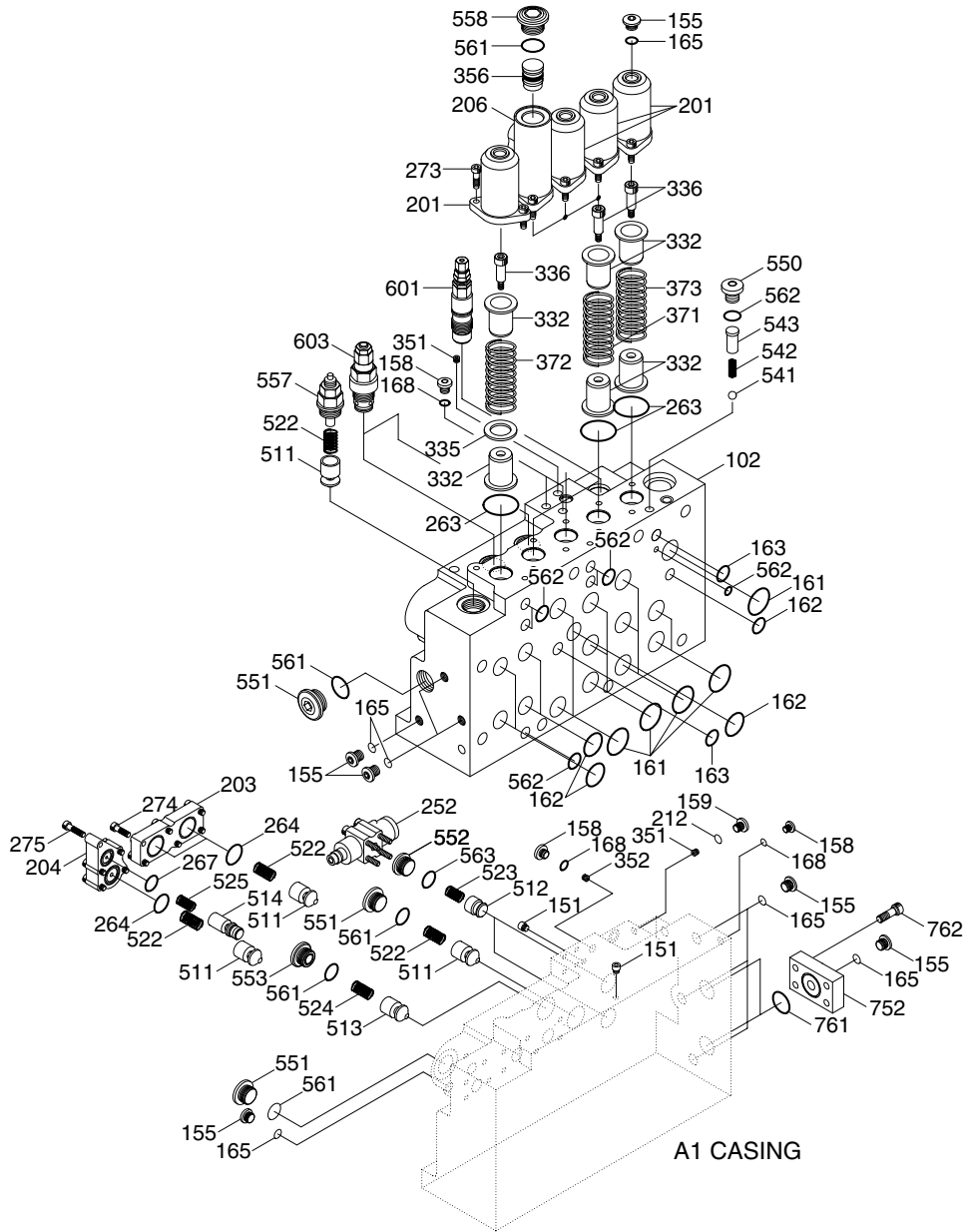

3809A8MC03

- | | | | | | |
|-----|--------------|-----|-------------|-----|------------------|
| 102 | Casing-B | 264 | O-ring | 542 | Spring seat |
| 151 | Plug | 267 | O-ring | 543 | Spring |
| 155 | Plug | 274 | Socket bolt | 550 | Plug |
| 158 | Plug | 275 | Screw | 551 | Plug |
| 159 | Plug | 335 | Shim | 552 | Plug |
| 161 | O-ring | 351 | Orifice | 557 | Plug |
| 162 | O-ring | 352 | Orifice | 558 | Plug |
| 163 | O-ring | 356 | Piston | 561 | O-ring |
| 165 | O-ring | 511 | Poppet | 562 | O-ring |
| 168 | O-ring | 512 | Poppet | 563 | O-ring |
| 201 | Spring cover | 514 | Poppet | 601 | Main relief assy |
| 203 | Spring cover | 522 | Spring | 603 | Port relief assy |
| 204 | Cover | 523 | Spring | 752 | Blank flange |
| 206 | Spring cover | 525 | Spring | 761 | O-ring |
| 212 | O-ring | 541 | Steel ball | 762 | Screw |
| 263 | O-ring | | | | |

STRUCTURE (4/4)

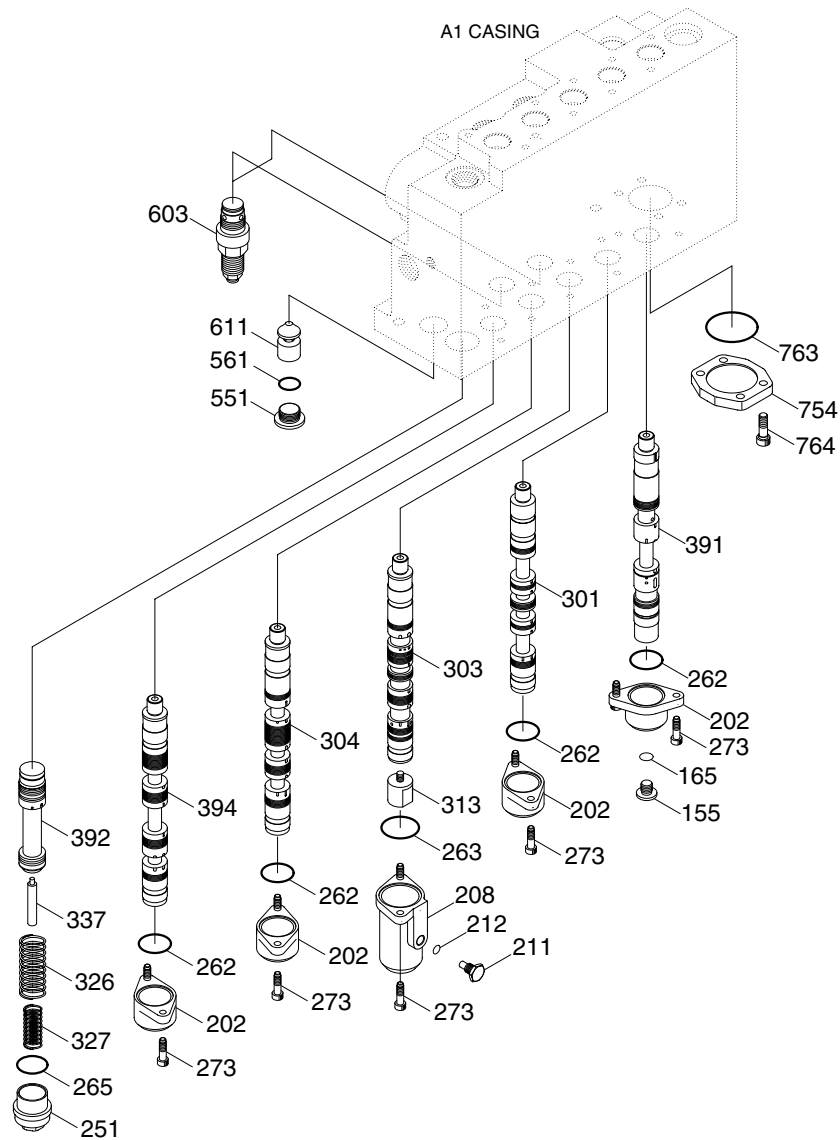

38098MC04

- | | | |
|------------------|-------------------------------|--------------------------------|
| 155 Plug | 273 Hex screw | 394 Am/Confluence spool kit |
| 165 O-ring | 301 Travel spool kit | 551 Plug |
| 202 Spring cover | 303 Boom spool kit | 561 O-ring |
| 208 Spool cover | 304 Bucket spool kit | 603 Port relief assy |
| 211 Plug | 313 Plug | 604 Port relief assy |
| 212 O-ring | 326 Spring | 611 Negative relief valve assy |
| 251 Plug | 327 Spring | 754 Flange |
| 262 O-ring | 337 Rod | 763 O-ring |
| 263 O-ring | 391 Travel straight spool kit | 764 Socket screw |
| 265 O-ring | 392 By pass cut spool | |

3. DISASSEMBLY AND ASSEMBLY

1) GENERAL PRECAUTIONS

- (1) All hydraulic components must be worked with precision working. Then, before disassembling and assembling them, it is essential to select an especially-clean place.
- (2) In handling a control valve, pay full attention to prevent dust, sand, etc. from entering into it.
- (3) When a control valve is to be removed from the machine, apply caps and masking seals to all ports. Before disassembling the valve, re-check that these caps and masking seals are fitted completely, and then clean the outside of the assembly. Use a proper bench for working, spread a paper or rubber mat on the bench, and disassemble the valve on it.
- (4) Support the body section carefully in carrying, transferring and so on of the control valve. Do not support the lever, exposed spool, end cover section or so on without fail.
- (5) After disassembling and assembling of the component, it is desired to carry out various tests (for the relief characteristics, leakage, flow resistance, etc.), but the hydraulic test equipment is necessary to these tests.
Therefore, even when its disassembling can be carried out technically, do not disassemble such component that cannot be tested, adjusted, and so on.
Besides, prepare clean cleaning oil, hydraulic oil, grease, etc. beforehand.

2) TOOLS

Before disassembling the control valve, prepare the following tools beforehand.

Name of tool	Quantity	Size (mm)
Vise bench	1 unit	-
Box wrench	Each 1 piece	22, 27, 32 & 36
Hexagon key wrench	Each 1 piece	5, 8, 12 & 17
Loctite #262	1 pc	-
Spanner	1 pc	10, 22, 24, 32 (Main relief valve), 36

3) DISASSEMBLING

(1) Place control valve on working bench.

※ Disassemble it in clean place and pay attention not to damage flange face.

(2) Disassembling of main spool (travel, bucket, swing, option, arm 2, boom 2, swing priority):

① Loosen hexagon socket head bolts (273) and remove spring cover (201), (206).
· Hexagon key wrench : 8 mm

In removing bucket spring cover (206), at first remove plug (558) and piston (356).

· Hexagon key wrench : 17 mm

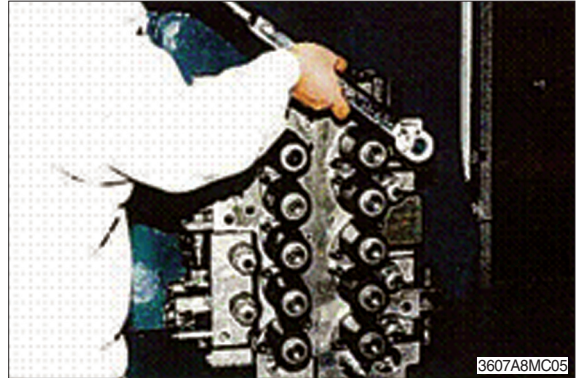

② Remove spool, spring, spring seats (shim) and spacer bolt in spool assembly condition from casing.

※ When pulling out spool assembly from casing, pay attention not to damage casing.

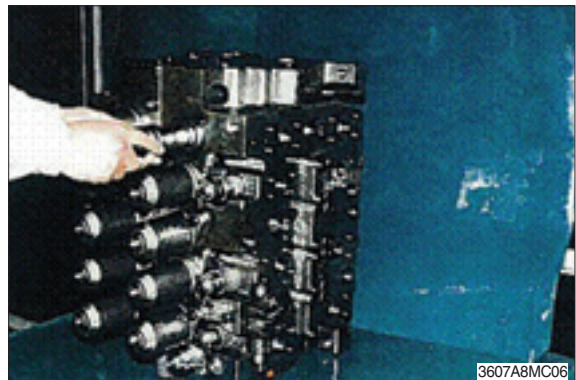

③ Hold spool in mouthpiece-attached vise. Remove spacer bolt (336) and disassemble spring (, shim) and spring seats.

· Hexagon key wrench : 12 mm

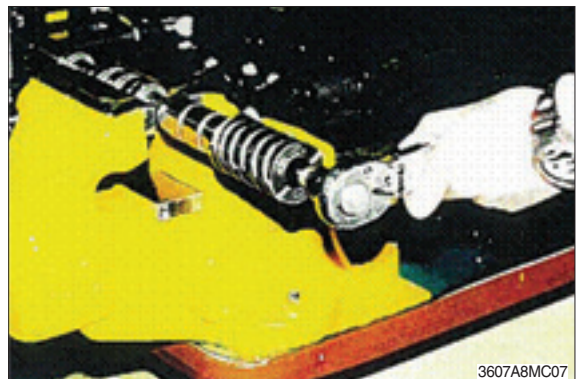

(3) Disassembling of arm 1 spool :

- ① Loosen hexagon socket head bolts (273) and remove spring cover (201).
 - Hexagon key wrench : 8 mm
 - ② Remove arm 1 spool (302), spring (371), spring seat (332) and spacer bolt (336) in spool assembly condition from casing.
- ※ When pulling out spool assembly from casing, pay attention not to damage casing.
- ③ Hold arm 1 spool (302) in mouthpiece-attached vise. Remove spacer bolt (336) and disassemble spring (371) and spring seats (332).
 - Hexagon key wrench : 12 mm
 - ④ Do not disassemble arm 1 spool (302) more than these conditions.

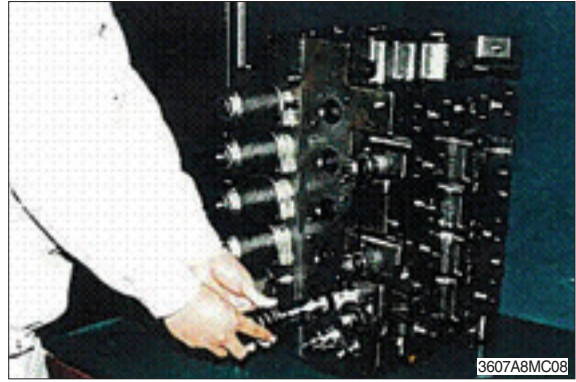

(4) Disassembling of travel straight spool :

- ① Loosen hexagon socket head bolts (273), remove spring cover, and pull out travel straight spool (391), spring (373), spring seat (332) and spacer bolt (336) in spool assembly condition from casing.
 - Hexagon key wrench : 8 mm
- ※ When pulling out spool assembly from casing, pay attention not to damage casing.
- ② Hold travel straight spool (391) in mouthpiece-attached vise, remove spacer bolt (336) and disassemble spring (373) and spring seats (332).
 - Hexagon key wrench : 12 mm
 - ③ Do not disassemble travel straight spool (391) more than these conditions.

(5) Disassembling of boom 1 spool :

- ① Loosen hexagon socket head bolts (273), remove spring cover (201) and pull out boom 1 spool (303), plug (313), spring (371), spring seats (332) and spacer bolt(336) in spool assembly condition from casing.

· Hexagon key wrench : 8 mm

- ※ When pulling out spool assembly from casing, pay attention not to damage casing.

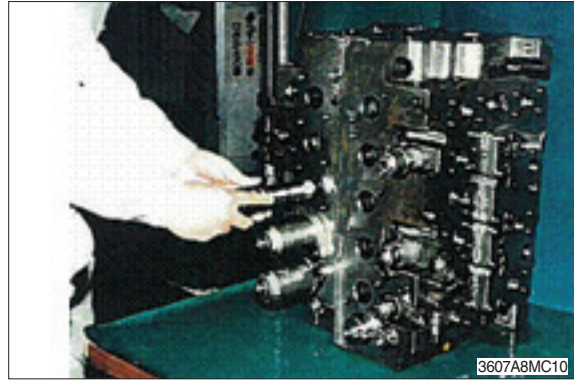

- ② Hold boom 1 spool (303) in mouthpiece-attached vise, remove spacer bolt (336), and disassemble spring (371) and spring seats (332).

· Hexagon key wrench : 12 mm

Remove plug (313).

· Spanner : 27 mm

- ③ Do not disassemble boom1 spool (303) more than these conditions.



(6) Disassembly of covers :

- ① Remove hexagon socket head bolts (273), and remove spool cover (202) and (208).

· Hexagon key wrench : 8 mm

In removing boom1 spool cover (208), at first remove plug (211).

· Box wrench : 22 mm

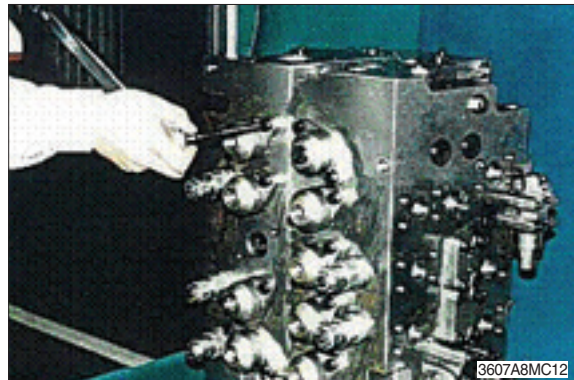

(7) Removal of main relief valve and port relief valves :

- ① Remove main relief valve (601) and port relief valve (603), (604), (605) from casing.

- Main relief valve : Spanner 32 mm
- Port relief valve : Box wrench 36 mm, Spanner 36mm

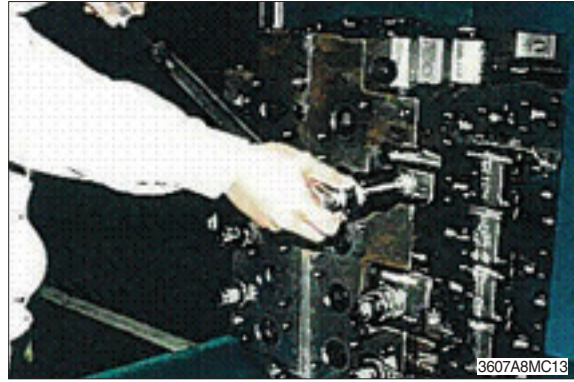

(8) Removal of lock valve assembly :

- ① Loosen hexagon socket head bolts and remove lock valve assembly (252).

- Hexagon key wrench : 5 mm



(9) Removal of bypass cut spool :

- ① Remove plug (251), spring (326 & 327), rod (337), and bypass cut spool (392).

- Box wrench : 27 mm

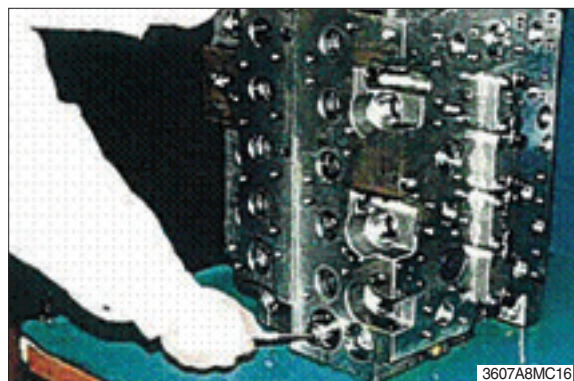

(10) Disassembly of negative control relief valve :

- ① Remove plug (551).
 - Hexagon key wrench : 17 mm

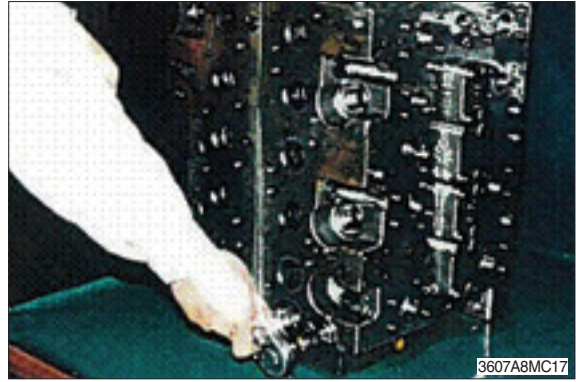

- ② Remove poppet (611), spring (621) and damping rod(631).

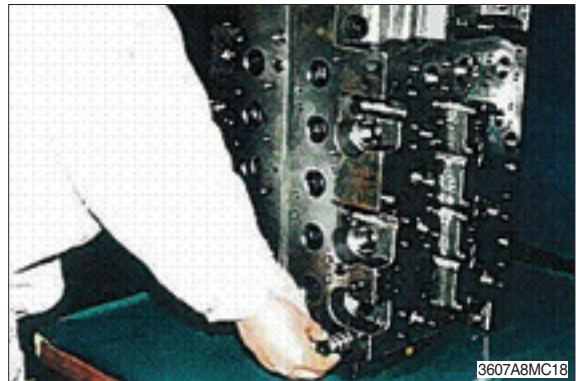

(11) Disassembly of check valve :

- ① Remove plug (551) and take out poppet (511) and spring (522).
 - Hexagon key wrench : 17 mm
- ② Loosen hexagon socket head bolts (274) and remove load check cover (203) and take out poppet (551) and spring (522).
 - Hexagon key wrench : 8 mm
- ③ Remove plug (553) and take out poppet (513) and spring (522).
 - Hexagon key wrench : 17 mm
- ④ Remove plug (552) and take out poppet (512) and spring (523).
 - Hexagon key wrench : 12 mm
- ⑤ Remove plug sub (557) and take out poppet (511) and spring (522).
 - Box wrench : 32 mm

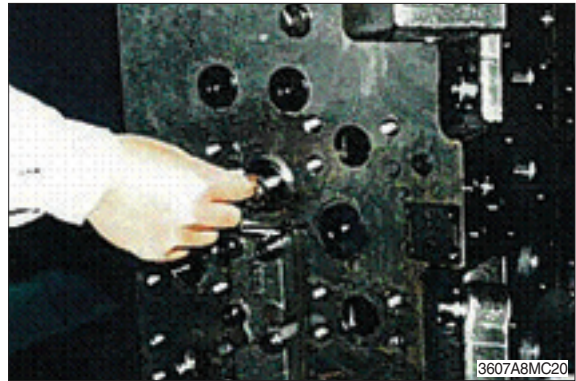

(12) Disassembly of boom priority valve :

- ① Loosen hexagon socket head bolts (276, 277) and remove cover sub (205) and poppet sub (515) of boom priority valve.
 - Hexagon key wrench : 8 mm
- ② Hold cover sub (205) in mouthpiece-attached vise, remove poppet sub (515).
- ③ Cover sub (205) :
Hold cover in mouthpiece-attached vise, Loosen plug (559), and remove piston (356).
 - Box wrench : 24 mm
- ④ Poppet sub (515) :
Remove ass'y of poppet (101, 102), plug (103) and spring (104) from bush (106).
- ⑤ Remove spring (105) and spool (107).
- ⑥ Do not disassemble ass'y in above
④ more than these conditions.

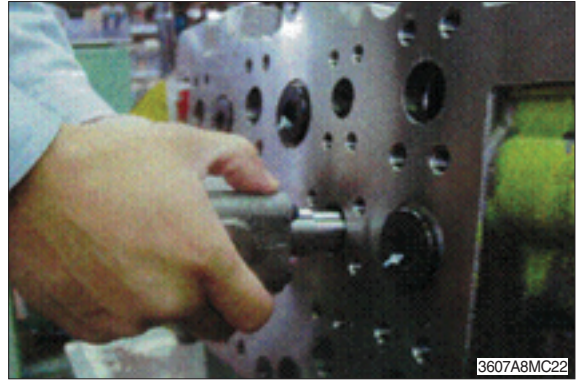

(13) Disassembly of casing :

- ① Except when required specially, do not disassemble tie bolts of casing A.
- ② Since plugs not described in above disassembling procedures are blind plugs for sacrifice holes and blind plugs for casing sanitation, do not disassemble them as far as not required specially.

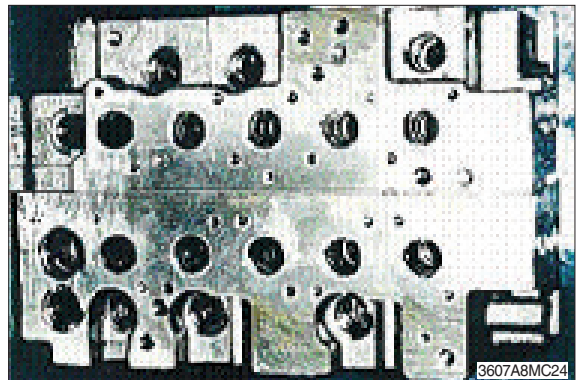

(14) Inspection after disassembling :

Clean all disassembled parts with clean mineral oil fully, and dry them with compressed air. Then, place them on clean papers or cloths for inspection.

① Control valve:

- a. Check whole surfaces of all parts for burrs, scratches, notches and other defects.
- b. Confirm that seal groove faces of casing and block are smooth and free of dust, dent, rust etc.
- c. Correct dents and damages on check seat faces of casing, if any, by lapping.
※ Pay attention not to leave lapping agent in casing.
- d. Confirm that all sliding and fitting parts can be moved manually and that all grooves and paths are free from foreign matter.
- e. If any spring is broken or deformed, replace it with new one.
- f. When relief valve do not function properly, repair it, following its disassembling assembling procedures.
- g. Replace all seats and O-rings with new ones.

② Relief valve:

- a. Confirm that all seat faces at ends of all poppets and seats are free of defects and are uniform contact faces.
- b. Confirm manually that main poppet and seat can slide lightly and smoothly.
- c. Confirm that outside face of main poppet and inside face of seat are free from scratches and so on.
- d. Confirm that springs are free from breaking, deformation, and wear.
- e. Confirm that orifices of main poppet and seat section are not clogged with foreign matter.
- f. Replace all O-rings with new ones.
- g. When any light damage is found in above inspections, correct it by lapping.
- h. When any abnormal part is found, replace it with a relief valve assembly.

4) ASSEMBLING

(1) In this assembling section, explanation only is shown. Refer to figures and photographs shown in disassembling section.

(2) Figure in () shown after part name in explanation sentence shows number in construction figure.

(3) Cautions in assembling seals

- ① Pay attention to keep seals free from defects in its forming and damages in its handling.
- ② Apply grease, hydraulic oil or so on to seals and seal-fitting sections for full lubrication.
- ③ Do not stretch seals so much to deform them permanently.
- ④ In fitting O-ring, pay attention not to roll it into its position. In addition, twisted O-ring cannot remove its twisting naturally with ease after being fitted, and causes oil leakage.
- ⑤ Tighten fitting bolts at all sections with torque wrench to their respective tightening torques shown in "Maintenance Standards".

(4) Assembly of check valve :

- ① Assemble poppets (511,513 & 512) and springs (522 & 523).

Put O-rings (561) onto plugs (551 & 553).

Put O-rings (563) onto plugs (552).

Put O-rings (264) on cover (203).

Tighten the latters with their specified torques.

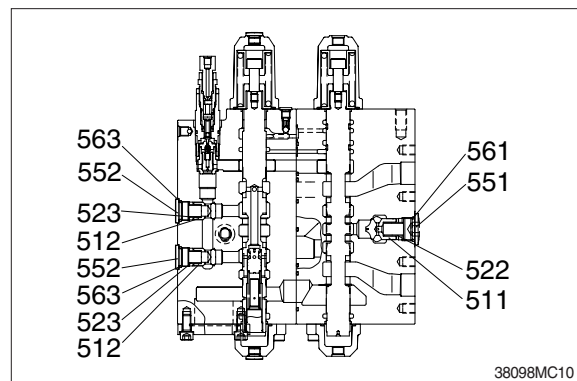

※ Use poppets, springs and plugs in following groups.

Poppet	Spring	Plug or cover	Remember that	
511	522	203, 204, 551, 557		511 in 10 positions
512	523	552		512 in 2 positions
513	522	553		513 in 2 positions
514	525	204		514 in 1 positions

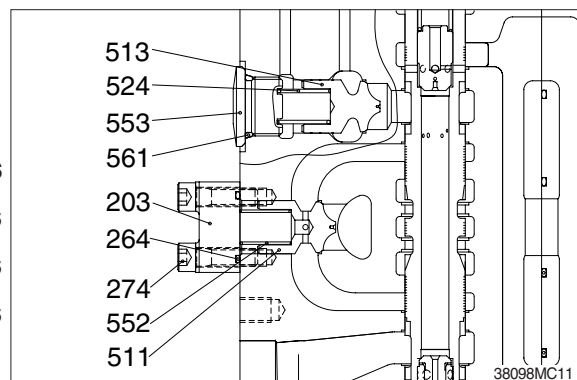

No.	Hexagon key wrench	Tightening torque	
		kgf · m	lbf · ft
(551)	17 mm	37.7~41.8	273~302
(274)	8 mm	5.3~6.3	38.3~45.6
(553)	17 mm	37.7~41.8	273~302
(552)	12 mm	23.5~27.5	170~197
(557)	(box wrench) 32 mm	20.4~25.5	148~184

② Bucket, option confluence plug sub :

If you want bucket confluence or option confluence effective, loosen rod (401) and tighten lock nut (712).

If you want to cancel bucket confluence or option confluence, tighten rod (401) and lock nut (712).

- Spanner : 10 mm for (401)
- Tightening torque : 3.0~4.0 kgf · m
(21.7~28.9 lbf · ft)
- Spanner : 24 mm for (712)
- Tightening torque : 4.0~5.0 kgf · m
(28.9~36.2 lbf · ft)

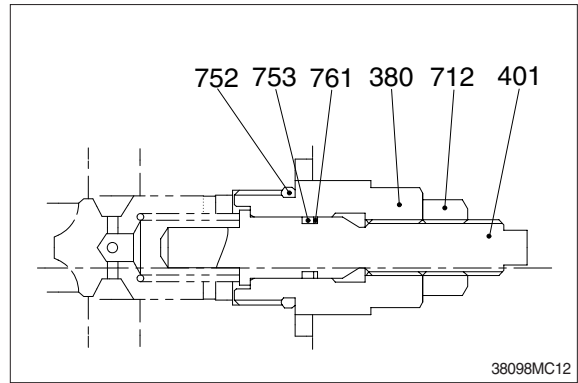

(5) Assemble boom priority valve :

- ① Put O-ring (108) onto bushing (106), and assemble spool (107) and spring (105).

Assemble assy of poppet (101, 102), plug (103) and spring (104) into bushing (106).

Assemble bushing sub in above ② into cover (205) and assemble them into casing, and tighten hexagon socket head bolts (276, 277)

- Hexagon key wrench : 8 mm
- Tightening torque : 5.3~6.3 kgf · m
(38.3~45.6 lbf · ft)

Assemble piston (356) in cover (205), and tighten plug (559)

- Box wrench : 24 mm
- Tightening torque : 20.4~25.5 kgf · m
(147.5~184.4 lbf · ft)

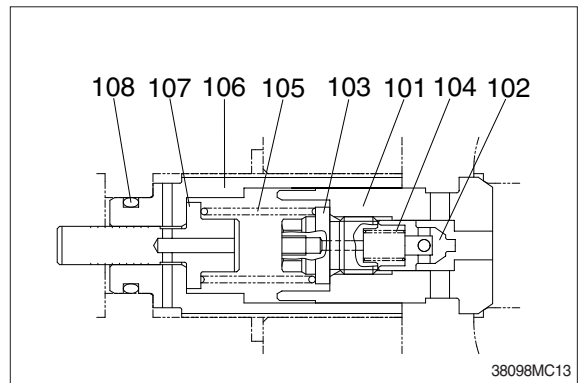

(6) Assembling of negative control relief valve

- ① Assemble poppet (611), spring (621), and damping rod (631) to casing A (101) & casing B(102). Put O-ring (561) onto plug (551) and tighten the latter with its specified torque.

- Hexagon key wrench : 17 mm
- Tightening torque : 37.7~41.8 kgf · m
(272.7~302.3 lbf · ft)

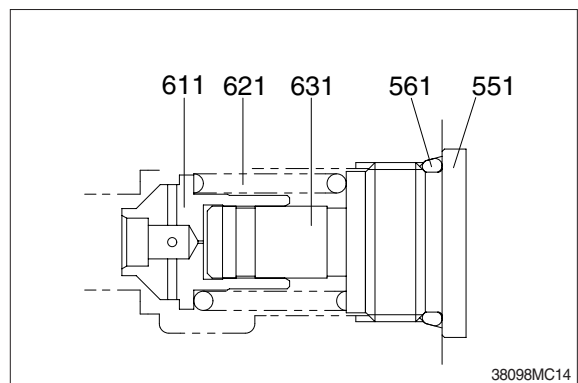

(7) Assembly of bypass cut valve

① Assemble bypass cut spool (392), spring (326 & 327) and rod (337) into casing A (101) & casing B(102).

Put O-ring (265) onto plug (251) and tighten the latter with its specified torque.

- Box wrench : 27 mm
- Tightening torque : 7.95~10.0 kgf · m
(57.5~72.3 lbf · ft)

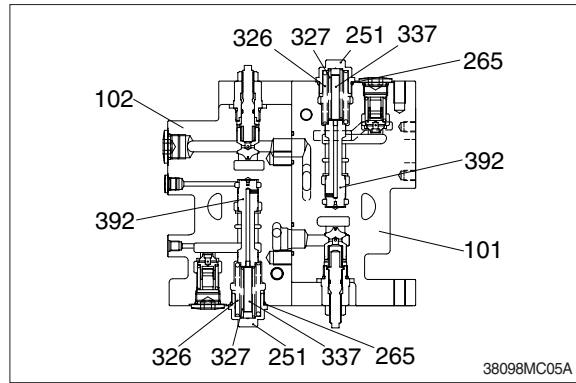

(8) Assembling of lock valve assembly

① Fit O-ring (163) to lock valve assembly (252) and tighten hexagon socket head bolts with specified torque.

- Hexagon key wrench : 5 mm
- Tightening torque : 1.0~1.42 kgf · m
(7.2~10.2 lbf · ft)

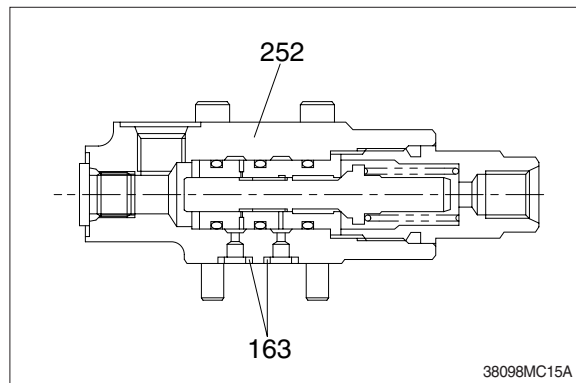

(9) Assembling of main relief valve and port relief valve :

① Assemble main relief valve (601) and port relief valves (603, 604, & 605) to casing and tighten it with specified torque.

Item	Size	Tightening torque	
		kgf · m	lbf · ft
Main relief valve	Spanner 32 mm	12.2~14.3	88.2~103
Port relief valve	Spanner 36 mm Box wrench 36 mm		

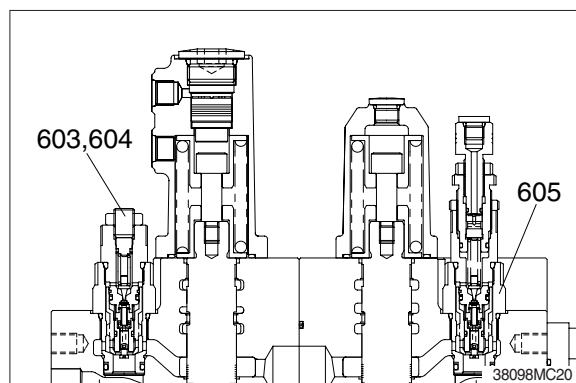
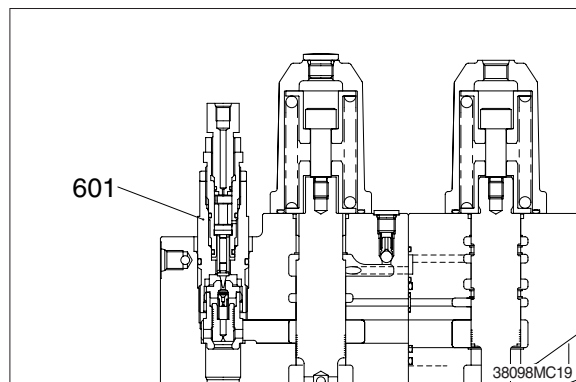

(10) Assembling of travel straight spool :

① Hold end of travel straight spool (391) in mouthpiece-attached vise, set spring seat (332) and spring (373) and tighten spacer bolt (336) with specified torque.

※ Before tightening spacer bolt (336), apply Loctite #262 to it.

- Hexagon key wrench : 12 mm
- Tightening torque : 3.77~4.18 kgf · m
(27.2~30.2 lbf · ft)

② Fit spool assemblies of items ① above into casing B (102).

※ Fit spool assemblies into casing B (102) carefully and slowly. Do not push them forcibly without fail.

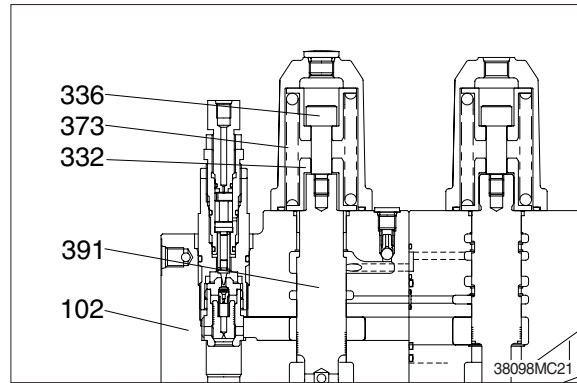

(11) Assembling of boom 1 spool :

① Hold the middle of boom 1 spool (303) in mouthpiece-attached vise, set spring seat (332) and spring (371) and tighten spacer bolt (336) with specified torque, and tighten plug (313) with specified torque.

※ Before tightening spacer bolt (336) and plug (313), apply Loctite #262 to them.

- Spacer bolt (336) : Hexagon key wrench 12 mm
- Tightening Torque : 3.77~4.18 kgf · m
(27.2~30.2 lbf · ft)
- Plug (313) : Spanner 27 mm
- Tightening Torque : 3.77~4.18 kgf · m
(27.2~30.2 lbf · ft)

② Fit spool assemblies of items ① above into casing B (102).

※ Fit spool assemblies into casing B (102) carefully and slowly. Do not push them forcibly without fail.

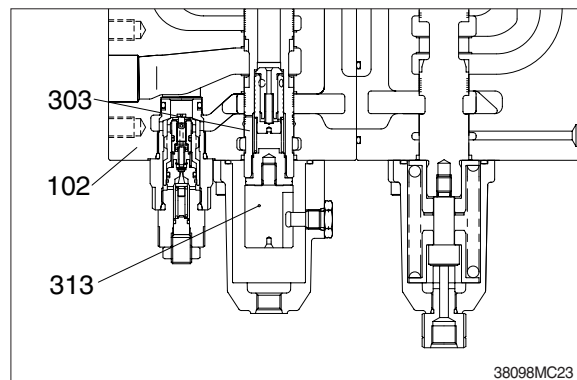
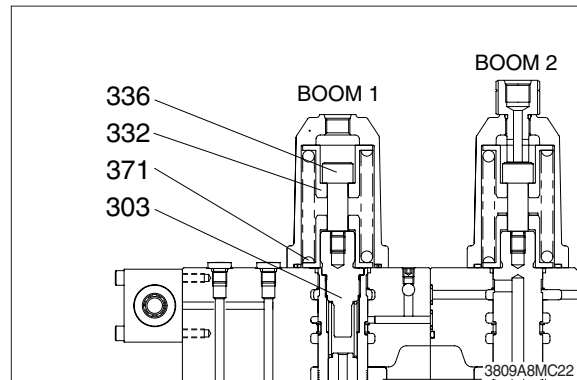

(12) Assembling of arm 1 spool :

① Hold end of arm 1 spool (302) in mouthpiece-attached vise, set spring seats (332) and spring (371) and tighten spacer bolt (336) with specified torque.

※ Before tightening spacer bolt (336), apply Loctite #262 to it.

- Hexagon key wrench : 12 mm
- Tightening Torque : 3.77~4.18 kgf · m
(27.2~30.2 lbf · ft)

② Fit spool assemblies of Items ① above into casing A (101).

※ Fit spool assemblies into casing A (101) carefully and slowly.

Do not push them forcibly without fail.

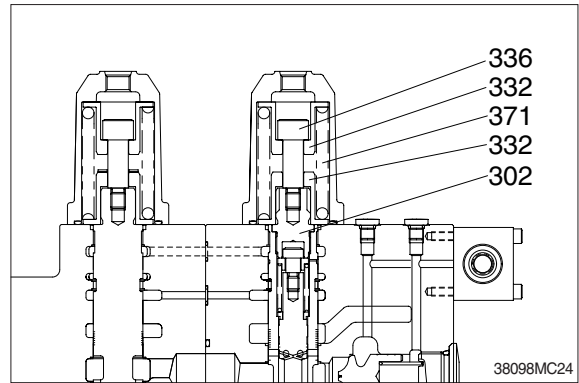

(13) Assembling of main spool (travel (301), bucket (304), swing (305), option (308), arm 2 (394), boom 2 (393), swing priority (395))

① Hold end of each spool in mouthpiece-attached vise, set spring seats, springs (shim (335) for arm 2, boom 2 and swing priority spool) and tighten spacer bolt (336) with specified torque.

※ Before tightening spacer bolt (336), apply Loctite #262 to it.

- Hexagon key wrench : 12 mm
- Tightening Torque : 3.77~4.18 kgf · m
(27.2~30.2 lbf · ft)

② Insert spool assemblies of Items ① above into casing.

※ Fit spool assemblies into casing A (101) and casing B (102) carefully and slowly.

Do not push them forcibly without fail.

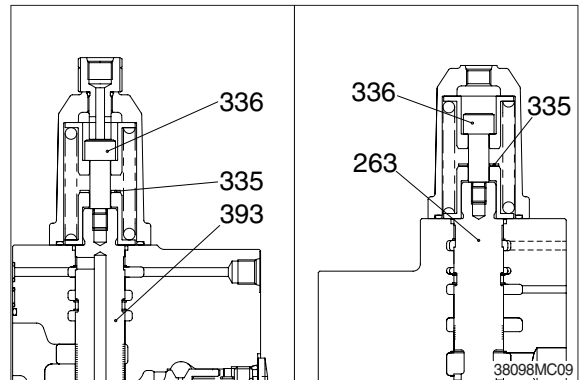

(14) Assembling of cover :

- ① Fit spool covers (202) and (208) to sides reverse to spring sides spools, and tighten hexagon socket head bolts (273) with specified torque.

※ Confirm that O-rings (262) have been fitted to spool cover (202), O-ring (263) to boom 1 spool cover (208).

- Hexagon key wrench : 8 mm
- Tightening torque : 5.3~6.3 kgf · m
(38.3~45.6 lbf · ft)

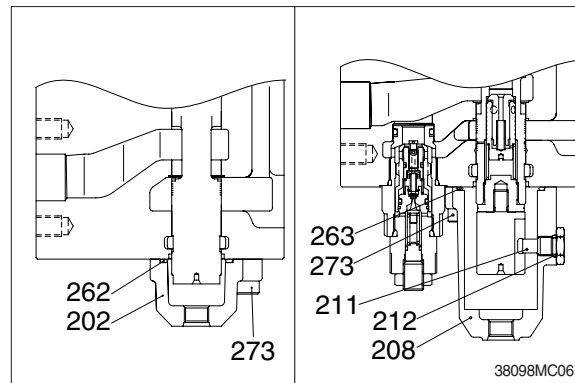

- ② Boom 1 spool cover :

Put O-ring (212) onto plug (211) and tighten the latter onto boom 1 spool cover (208) with its specified torque.

- Box wrench : 22 mm
- Tightening torque : 3.5~4.0 kgf · m
(25.3~29 lbf · ft)

- ③ Fit spring covers (201), (206) to spring sides of spools, and tighten hexagon socket head bolts (273) with specified torque.

※ Confirm that O-rings (263) have been fitted.

- Hexagon key wrench : 8 mm
- Tightening torque : 5.3~6.3 kgf · m
(38.3~45.5 lbf · ft)

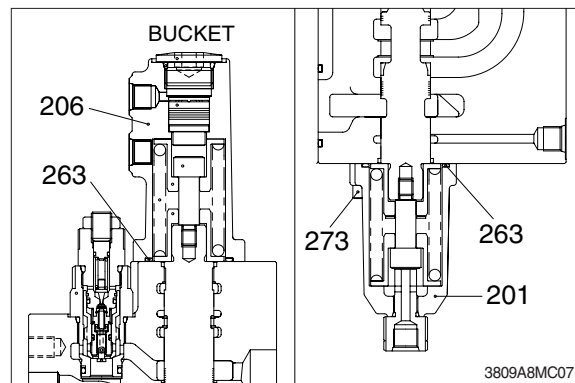

- ④ Bucket spring cover :

Assemble piston (356) to bucket spring cover (206). Put O-ring (561) onto plug (558) and tighten the latter with specified torque.

- Hexagon key wrench : 17 mm
- Tightening torque : 20.1~25.1 kgf · m
(144.6~180.8 lbf · ft)

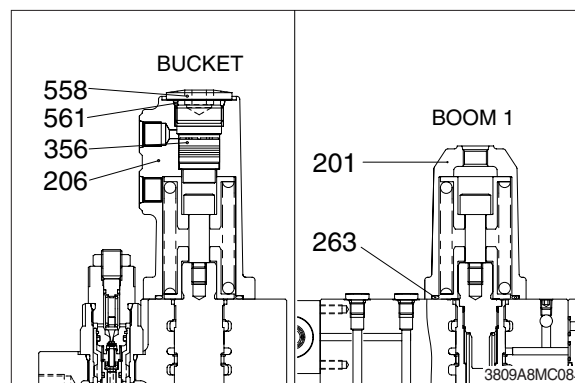

- ⑤ Boom 1 spring cover :

Fit spring cover (201) to spring sides and tighten hexagon socket head bolts (273) with specified torque.

※ Confirm that O-rings (263) have been fitted.

- Hexagon key wrench : 8 mm
- Tightening torque : 5.3~6.3 kgf · m
(38.3~45.5 lbf · ft)