

SECTION 3 HYDRAULIC SYSTEM

Group 1 Hydraulic Circuit	3-1
Group 2 Main Circuit	3-2
Group 3 Pilot Circuit	3-5
Group 4 Single Operation	3-13
Group 5 Combined Operation	3-23

GROUP 1 HYDRAULIC CIRCUIT

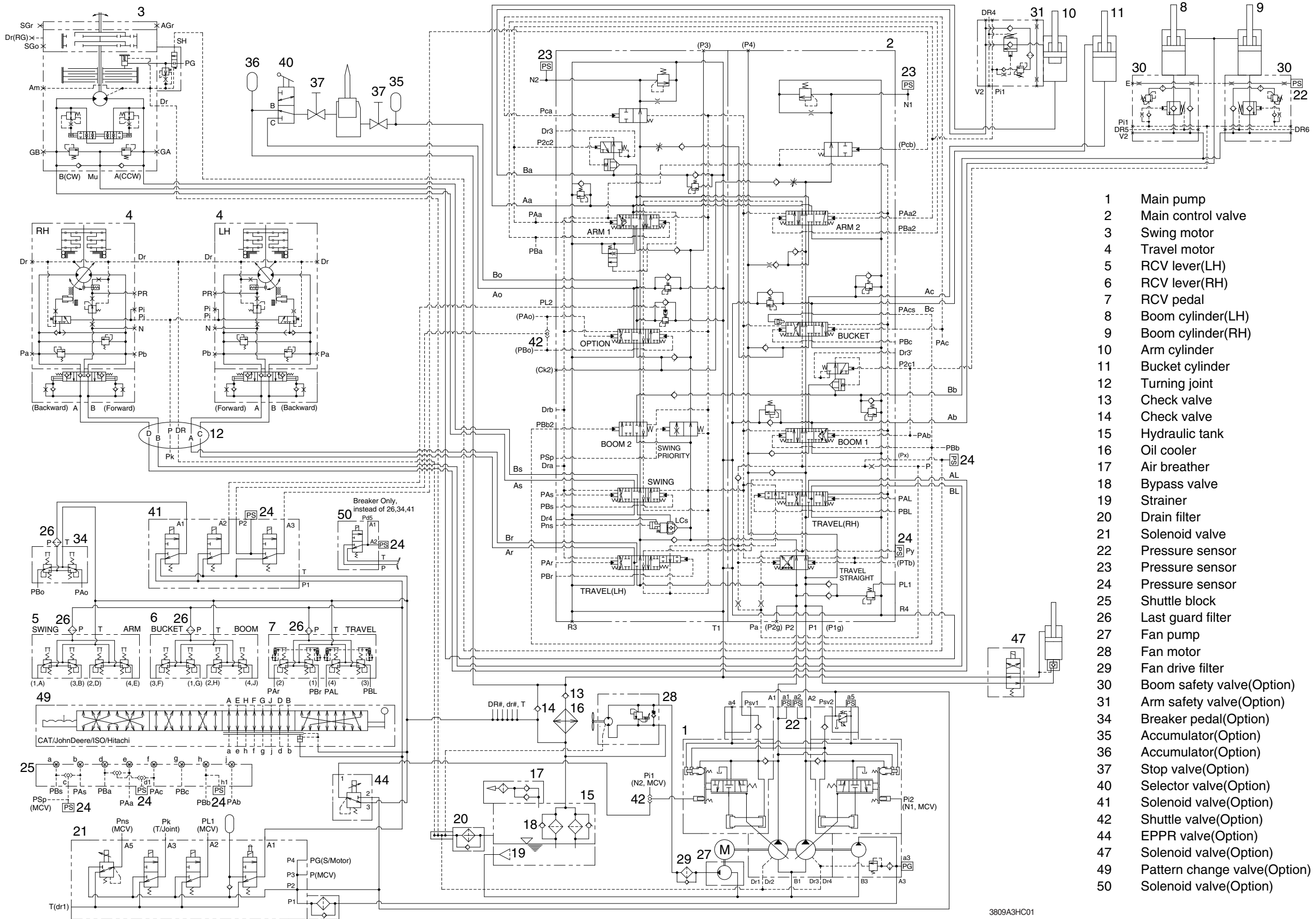

- 1 Main pump
- 2 Main control valve
- 3 Swing motor
- 4 Travel motor
- 5 RCV lever(LH)
- 6 RCV lever(RH)
- 7 RCV pedal
- 8 Boom cylinder(LH)
- 9 Boom cylinder(RH)
- 10 Arm cylinder
- 11 Bucket cylinder
- 12 Turning joint
- 13 Check valve
- 14 Check valve
- 15 Hydraulic tank
- 16 Oil cooler
- 17 Air breather
- 18 Bypass valve
- 19 Strainer
- 20 Drain filter
- 21 Solenoid valve
- 22 Pressure sensor
- 23 Pressure sensor
- 24 Pressure sensor
- 25 Shuttle block
- 26 Last guard filter
- 27 Fan pump
- 28 Fan motor
- 29 Fan drive filter
- 30 Boom safety valve(Optional)
- 31 Arm safety valve(Optional)
- 34 Breaker pedal(Optional)
- 35 Accumulator(Optional)
- 36 Accumulator(Optional)
- 37 Stop valve(Optional)
- 40 Selector valve(Optional)
- 41 Solenoid valve(Optional)
- 42 Shuttle valve(Optional)
- 44 EPPR valve(Optional)
- 47 Solenoid valve(Optional)
- 49 Pattern change valve(Optional)
- 50 Solenoid valve(Optional)

3809A3HC01