

GROUP 2 ENGINE SYSTEM

ENGINE AND ACCESSORIES MOUNTING

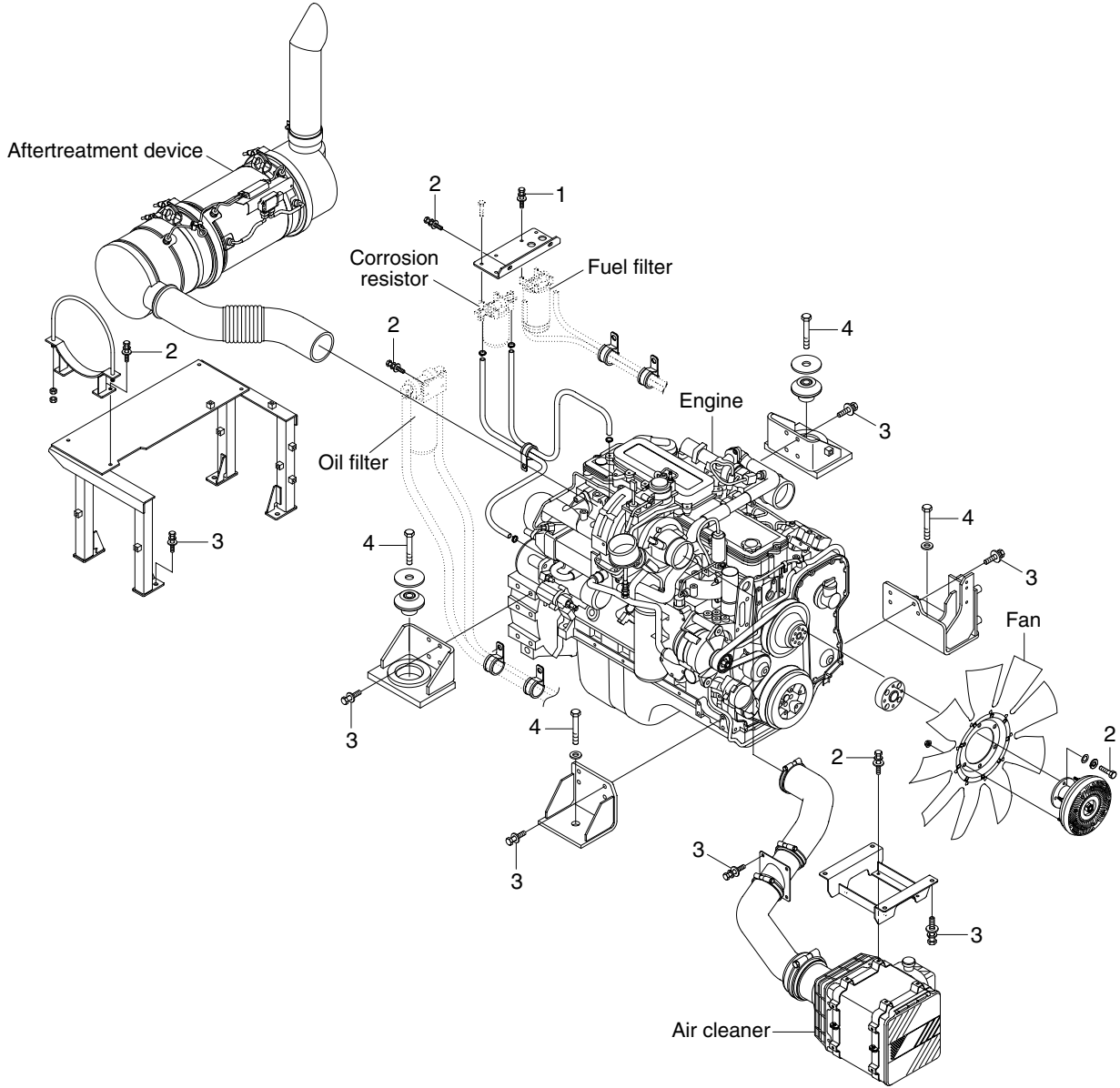

3809A9CM01

· Tightening torque

Item	Size	kgf · m	lbf · ft
1	M 8 × 1.25	2.5 ± 0.5	18.1 ± 3.6
2	M10 × 1.5	6.9 ± 1.4	49.9 ± 10.1

Item	Size	kgf · m	lbf · ft
3	M12 × 1.75	12.8 ± 3.0	92.6 ± 21.7
4	M24 × 3.0	90 ± 7.0	651 ± 51

COOLING SYSTEM AND FUEL TANK MOUNTING

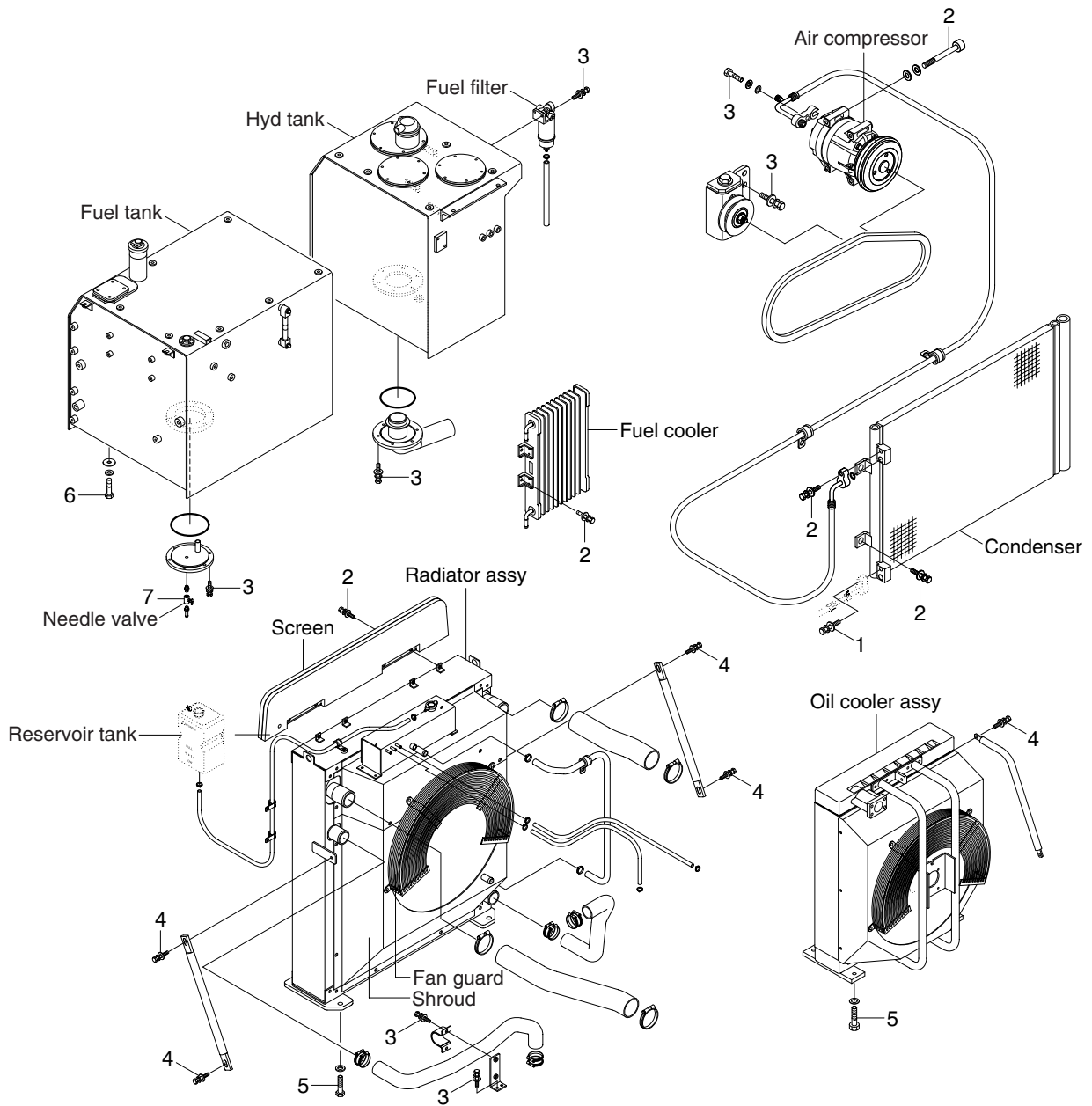

3809A9CM02

· Tightening torque

Item	Size	kgf · m	lbf · ft
1	M 6×1.0	0.5±0.2	3.6±1.45
2	M 8×1.25	2.5±0.5	18.1±3.6
3	M10×1.5	6.9±1.4	49.4±10.1
4	M12×1.75	12.8±3.0	92.6±21.7

Item	Size	kgf · m	lbf · ft
5	M16×2.0	29.7±4.5	215±32.5
6	M20×2.5	46±5.1	333±36.9
7	-	2.3±0.6	16.6±4.3
-	-	-	-