

GROUP 2 MAJOR COMPONENT

1. MAIN PUMP

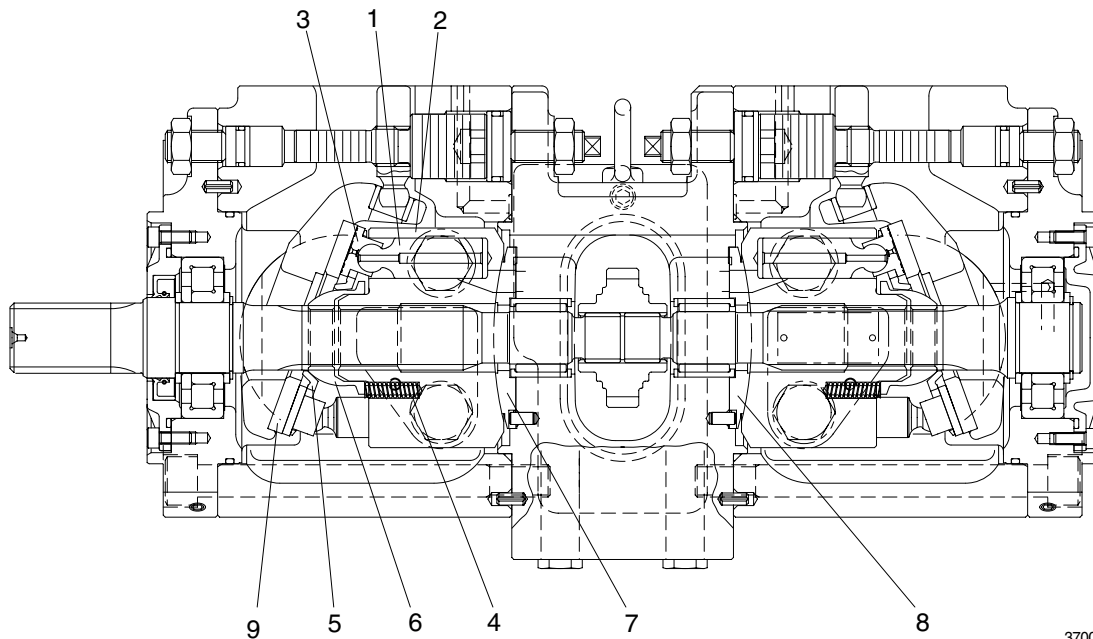

370077MP01

Part name & inspection item		Standard dimension	Recommended replacement value	Counter measures
Clearance between piston(1) & cylinder bore(2) (D-d)		0.038	0.078	Replace piston or cylinder.
Play between piston(1) & shoe caulking section(3) (δ)		0-0.1	0.35	Replace assembly of piston & shoe.
Thickness of shoe (t)		5.4	5.0	
Free height of cylinder spring(4) (L)		40.9	40.1	Replace cylinder spring.
Combined height of set plate(5) & spherical bushing(6) (H-h)		23.8	22.8	Replace retainer or set plate.
Surface roughness for valve plate(Sliding face)(7,8), swash plate (shoe plate area)(9), & cylinder(2)(Sliding face)	Surface roughness necessary to be corrected	3z		Lapping
	Standard surface roughness (Corrected value)	0.4z or lower		

2. MAIN CONTROL VALVE

Part name	Inspection item	Criteria & measure
Casing	<ul style="list-style-type: none"> · Existence of scratch, rusting or corrosion. 	<ul style="list-style-type: none"> · In case of damage in following section, replace part. - Sliding sections of casing fore and spool, especially land sections applied with holded pressure. - Seal pocket section where spool is inserted. - Seal section of port where O-ring contacts. - Seal section of each relief valve for main, travel, and port. - Other damages that may damage normal functions.
Spool	<ul style="list-style-type: none"> · Existence of scratch, gnawing, rusting or corrosion. · O-ring seal sections at both ends. · Insert spool in casing hole, rotate and reciprocate it. 	<ul style="list-style-type: none"> · Replacement when its outside sliding section has scratch(Especially on seals-contacting section). · Replacement when its sliding section has scratch. · Correction or replacement when O-ring is damaged or when spool does not move smoothly.
Poppet	<ul style="list-style-type: none"> · Damage of poppet or spring · Insert poppet into casing and function it. 	<ul style="list-style-type: none"> · Correction or replacement when sealing is incomplete. · Normal when it can function lightly without being caught.
Around spring	<ul style="list-style-type: none"> · Rusting, corrosion, deformation or breaking of spring, spring seat, plug or cover. 	<ul style="list-style-type: none"> · Replacement for significant damage.
Around seal for spool	<ul style="list-style-type: none"> · External oil leakage. · Rusting, corrosion or deformation of seal plate. 	<ul style="list-style-type: none"> · Correction or replacement. · Correction or replacement.
Main relief valve, port relief valve & negative control relief valve	<ul style="list-style-type: none"> · External rusting or damage. · Contacting face of valve seat. · Contacting face of poppet. · Abnormal spring. · O-rings, back up rings and seals. 	<ul style="list-style-type: none"> · Replacement. · Replacement when damaged. · Replacement when damaged. · Replacement. · 100% replacement in general.

3. SWING DEVICE

Part name	Inspection item	Remedy
Balance plate	<ul style="list-style-type: none"> · Worn less than 0.03mm · Worn more than 0.03mm · Sliding surface has a seizure(Even though small). 	<ul style="list-style-type: none"> · Lapping · Replacement · Replacement
Shoe of piston assembly	<ul style="list-style-type: none"> · Sliding surface has a damage. · Sliding surface depression() dimension less than 0.45mm or has a large damage. 	<ul style="list-style-type: none"> · Lapping · Replace parts or motor
Piston of piston assembly	<ul style="list-style-type: none"> · Sliding surface has a seizure(Even though small). 	<ul style="list-style-type: none"> · Replace motor
Piston hole of cylinder assembly	<ul style="list-style-type: none"> · Sliding surface has a seizure. · Sliding surface has a damage. 	<ul style="list-style-type: none"> · Replace motor · Replace motor
Taper roller bearing, Needle bearing Roller bearing	<ul style="list-style-type: none"> · In case 3000hour operation. · Rolling surface has a damage. 	<ul style="list-style-type: none"> · Replacement · Replacement

4. TRAVEL MOTOR

Replace parts in accordance with the following standards. However, if a part is damaged significantly in terms of its appearance, replace it irrespective of the standards.

1) HYDRAULIC MOTOR

Part name & inspection item	Standard dimension	Recommended value for replacement	Remedy
Clearance between piston & cylinder bore(D-d)	0.052mm	0.077mm	Replacement
Clearance caulked part between piston and shoe(δ)	0.1mm	0.3mm	Replacement
Thickness of shoe	5.5mm	5.3mm	Replacement
Assembled height of spherical bush and set plate(H-h)	23.8mm	23.3mm	Replacement as a set
Free length of cylinder spring	40.9mm	40.3mm	Replacement
Shaft over pin dia. Output spline Cylinder spline	43.91($\varnothing 5$) 49.06($\varnothing 5$)	43.31mm 48.46mm	Replacement if either one reaches replacement value.
Spline over dia. Spline in cylinder Spline in spherical bushing	35.25($\varnothing 5$)	35.75mm	Replacement
Thickness of separation plate Thickness of friction plate	1.5mm 3.9mm	1.3mm 3.7mm	Replacement
Free length of brake spring	42.4mm	41.4mm	Replacement
Displacement over teeth Over pin dia. of friction plate internal teeth	50.02(7teeth) 152.97($\varnothing 5$)	49.42mm 153.57mm	Replacement Replacement
Roughness of sliding surfaces Swash plate/shoe Cylinder block/valve plate	0.4 - z 0.4 - z	3 - z 3 - z	Each independent lapping Mutual lapping
Roller bearing Needle bearing	-	-	Replacement if flaking is found on rolling surface.
O-ring Oil seal	-	-	Replacement at every disassembly, in principle.

Part name & inspection item	Standard dimension	Recommended value for replacement	Remedy
Bolt	-	-	Replacement if elongation is found.

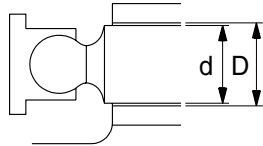

clearance between piston and cylinder bore : $D-d$

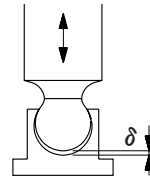

Play at caulking between piston and shoe : δ

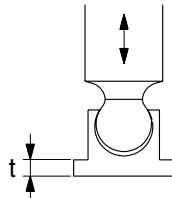

Thickness of shoe : t

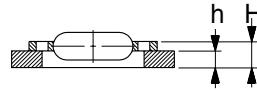

Assembled height of set plate and spherical bushing : $H-h$

2) REDUCTION GEAR

Part name & inspection item		Standard dimension	Recommended value for replacement	Remedy
Pitting or crack of gear		-	Pitting area rate : 10%	Replacement pitting or crack is found
Motor driving gear external spline		Overpin 43.91(∅ 5)	43.31mm	(Z=14)
No. 1 sun gear internal spline		Overpin 30.25(∅ 5)	30.85mm	Replacement (Z=14)
Reduction ratio $i = 70.145$	No. 1 sun gear	Displacement 42.22(4teeth)	41.92mm	Do. (Z=23)
	No. 1 planetary gear	Displacement 43.98(4teeth)	43.68mm	Do. (Z=26)
No. 1 carrier internal spline		Overpin 81.562(∅ 5)	82.162mm	Do. (Z=23)
No. 2 sun gear		Displacement 31.40(3teeth)	31.10mm	Do. (Z=23)
No. 2 planetary gear		Displacement 43.67(4teeth)	43.37mm	Do. (Z=26)
No. 2 carrier internal spline		Overpin 112.24(∅ 10)	112.84mm	Do. (Z=25)
No. 3 sun gear		Displacement 54.92(4teeth)	54.62mm	Do. (Z=25)
No. 3 planetary gear		Displacement 54.93(3teeth)	54.63mm	Do. (Z=22)
Ring gear (3rd stages)		Overpin 348.74(∅ 8.5)	349.34mm	Do. (Z=71)
Crack and flaking of bearing inner/outer races and rollers		-	-	Replacement if crack or flaking is found.
Crack and flaking of 1st/2nd/3rd planetary gears and pins		-	-	Replacement if crack or flaking is found.

Part name & inspection item	Standard dimension	Recommended value for replacement	Remedy
Radial clearance of needle bearing	0.01-0.04mm	0.07mm	Replacement of abnormal parts as a set.
Crack of spline contact part	-	-	Replacement if such damage as crack, crevice of chipping is found.
Backlash of spline contact part	0.1-0.3mm	0.5mm	Dimension check and replacement according to following standards.
Thrust ring(026)	7mm thick	6.6mm	Replacement if severe wear or seizure is found on sliding surface.
Thrust ring(027)	8mm thick	7.6mm	
Floating seal	-	-	Replacement of scratch or rust is found in sliding surface. Replacement if O-ring is deformed or damaged.
Gear oil	SAE 85W-140 (API GL-5)	-	1st time : 500hr 2nd time and later : Every 2000hr After disassembling, fill with new oil without fail. <div style="border-left: 1px solid black; border-right: 1px solid black; border-bottom: 1px solid black; padding: 2px 10px;"> The above times are measured with engine hour meter. </div>

5. RCV LEVER

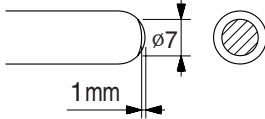
Maintenance check item	Criteria	Remark
Leakage	The valve is to be replaced when the leakage becomes more than 1000cc/m at neutral handle position, or more than 2000cc/m during operation.	Conditions : Primary pressure : 30kgf/cm ² Oil viscosity : 23cSt
Spool	This is to be replaced when the sliding surface has worn more than 10 μm, compared with the non-sliding surface.	The leakage at the left condition is estimated to be nearly equal to the above leakage.
Push rod	 <p>This is to be replaced when the top end has worn more than 1mm.</p>	
Play at operating section	The pin, shaft, and joint of the operating section are to be replaced when their plays become more than 2mm due to wears or so on.	When a play is due to looseness of a tightened section, adjust it.
Operation stability	When abnormal noises, hunting, primary pressure drop, etc. are generated during operation, and these cannot be remedied, referring to section 6. Troubleshooting, replace the related parts.	

- Notes
1. It is desirable to replace seal materials, such as O-rings, every disassembling. However, they may be reused, after being confirmed to be free of damage.
 2. When loosening the plug(3), replace the O-ring(4) without fail.

6. RCV PEDAL

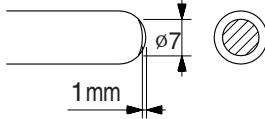
Maintenance check item	Criteria	Remark
Leakage	The valve is to be replaced when the leakage effect to the system. For example, the primary pressure drop.	Conditions : Primary pressure : 30kgf/cm ² Oil viscosity : 23cSt
Spool	This is to be replaced when the sliding surface has worn more than 10 μm, compared with the non-sliding surface.	The leakage at the left condition is estimated to be nearly equal to the above leakage.
Push rod	 <p>This is to be replaced when the top end has worn more than 1 mm.</p>	
Play at operating section	The pin, shaft, and joint of the operating section are to be replaced when their plays become more than 2mm due to wears or so on.	When a play is due to looseness of a tightened section, adjust it.
Operation stability	When abnormal noises, hunting, primary pressure drop, etc. are generated during operation, and these cannot be remedied, referring to section 6. Troubleshooting, replace the related parts.	

Notes 1. It is desirable to replace seal materials, such as O-rings, every disassembling. However, they may be reused, after being confirmed to be free of damage.

7. TURNING JOINT

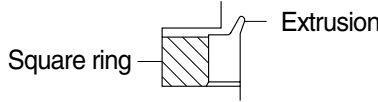
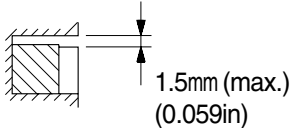
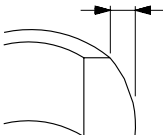
Part name		Maintenance standards	Remedy
Body, Stem	Sliding surface with sealing sections.	Plating worn or peeled due to seizure or contamination.	Replacement
	Sliding surface between body and stem other than sealing section.	• Worn abnormality or damaged more than 0.1mm (0.0039in) in depth due to seizure contamination.	Replacement
		• Damaged more than 0.1mm(0.0039in) in depth.	Smooth with oilstone.
	Sliding surface with thrust plate.	• Worn more than 0.5mm(0.02in) or abnormality.	Replacement
• Worn less than 0.5mm(0.02in).		Smooth	
• Damage due to seizure or contamination remediable within wear limit 0.5mm(0.02in).		Smooth	
Cover	Sliding surface with thrust plate.	• Worn more than 0.5mm(0.02in) or abnormality.	Replacement
		• Worn less than 0.5mm(0.02in).	Smooth
		• Damage due to seizure or contamination remediable within wear limit 0.5mm(0.02in).	Replacement
Seal set	-	<ul style="list-style-type: none"> • Extruded excessively from seal groove square ring. 	Replacement
	-	<ul style="list-style-type: none"> • Slipper ring 1.5mm(0.059in) narrower than seal groove, or narrower than back ring. 	Replacement
	-	<ul style="list-style-type: none"> • Worn more than 0.5mm(0.02in) ~ 1.5mm(MAX.) (0.059in) 	Replacement

8. CYLINDER

Part name	Inspecting section	Inspection item	Remedy
Piston rod	· Neck of rod pin	· Presence of crack	· Replacement
	· Weld on rod hub	· Presence of crack	· Replacement
	· Stepped part to which piston is attached.	· Presence of crack	· Replacement
	· Threads	· Presence of crack	· Recondition or replacement
	· Plated surface	· Plating is not worn off to base metal.	· Replace or replate
		· Rust is not present on plating. · Scratches are not present.	· Replace or replate · Recondition, replate or replace
	· Rod	· Wear of O.D.	· Recondition, replate or replace
· Bushing at mounting part	· Wear of I.D.	· Replacement	
Cylinder tube	· Weld on bottom	· Presence of crack	· Replacement
	· Weld on head	· Presence of crack	· Replacement
	· Weld on hub	· Presence of crack	· Replacement
	· Tube interior	· Presence of faults	· Replace if oil leak is seen
	· Bushing at mounting part	· Wear on inner surface	· Replacement
Gland	· Bushing	· Flaw on inner surface	· Replace if flaw is deeper than coating