

GROUP 4 MAIN CONTROL VALVE

1. REMOVAL AND INSTALL

1) REMOVAL

- (1) Lower the work equipment to the ground and stop the engine.
- (2) Operate the control levers and pedals several times to release the remaining pressure in the hydraulic piping.
- (3) Loosen the breather slowly to release the pressure inside the hydraulic tank.

▲ Escaping fluid under pressure can penetrate the skin causing serious injury.

※ When pipes and hoses are disconnected, the oil inside the piping will flow out, so catch it in oil pan.

- (4) Remove bolts and disconnect pipes.
- (5) Disconnect pilot line hoses.
- (6) Disconnect pilot pipes.
- (7) Sling the control valve assembly and remove the control valve mounting bolts.
 - Weight : 250kg(550lb)
- (8) Remove the control valve assembly.

When removing the control valve assembly, check that all the piping have been disconnected.

2) INSTALL

- (1) Carry out installation in the reverse order to removal.
- (2) Bleed the air from below items.
 - ① Cylinder(Boom, arm, bucket)
 - ② Swing motor
 - ③ Travel motor

※ See each item removal and install.
- (3) Confirm the hydraulic oil level and recheck the hydraulic oil leak or not.

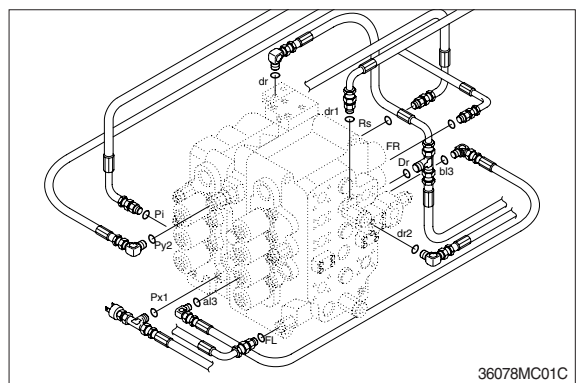
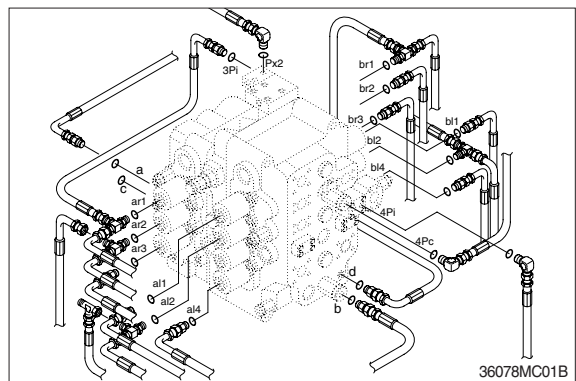
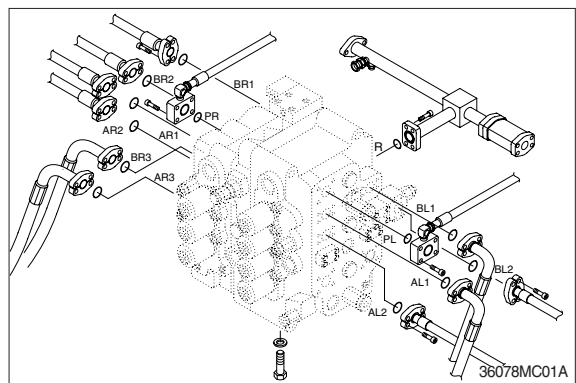

2. STRUCTURE (1/3)

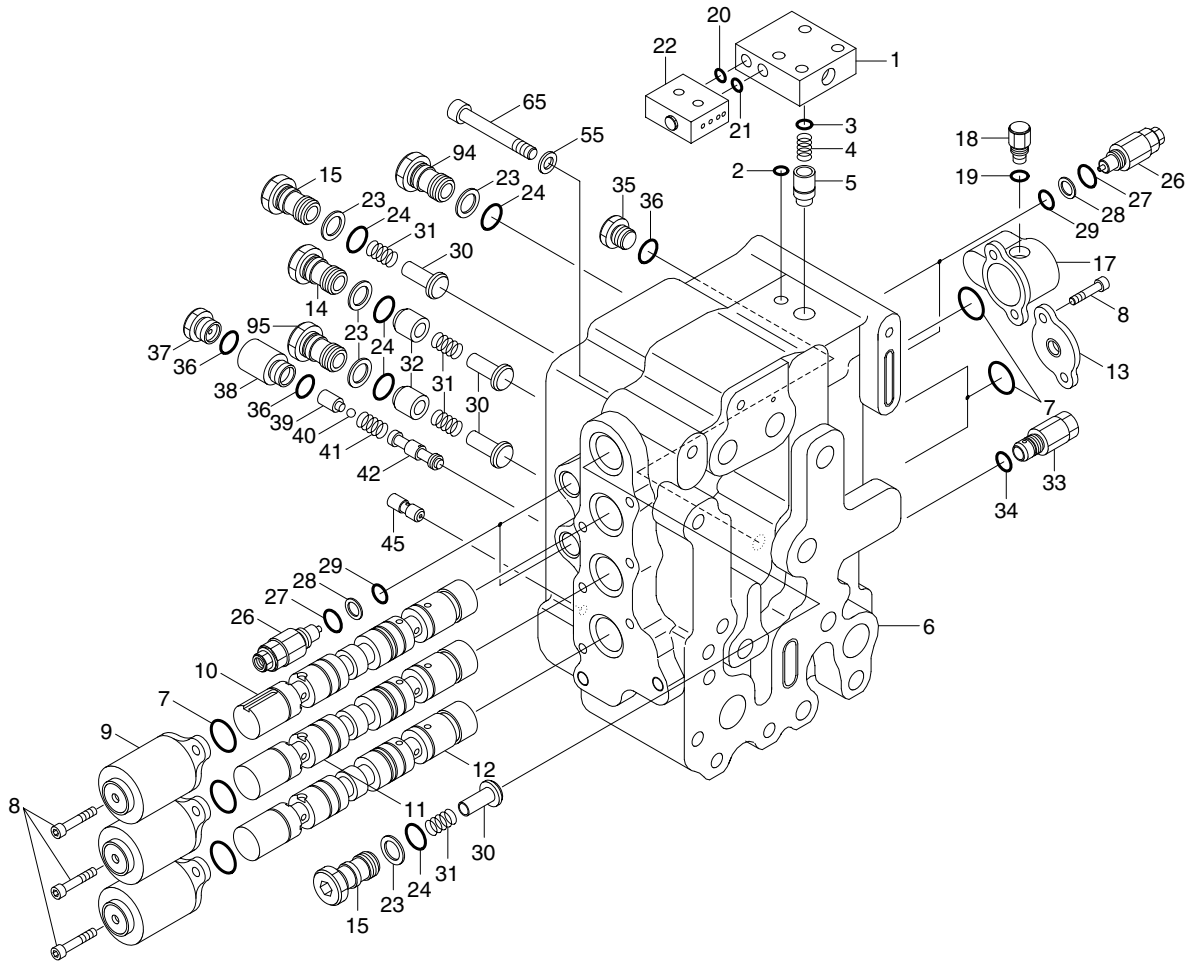

3607A8MC02

1	Cover assy	17	Cover	33	Foot relief valve
2	O-ring	18	Plug	34	O-ring
3	O-ring	19	O-ring	35	Cap
4	Spring	20	O-ring	36	O-ring
5	Poppet	21	O-ring	37	Cap
6	Housing	22	Selector assy	38	Cap
7	O-ring	23	Back up ring	39	Piston
8	Socket bolt	24	O-ring	40	Steel ball
9	Cover	26	Overload relief valve	41	Spring
10	Boom plunger assy	27	O-ring	42	Spool
11	Bucket plunger assy	28	Back up ring	45	Orifice
12	Travel plunger assy	29	O-ring	55	Washer
13	Cover	30	Check	65	Socket bolt
14	Cap	31	Spring	94	Cap
15	Cap	32	Check	95	Cap

STRUCTURE (2/3)

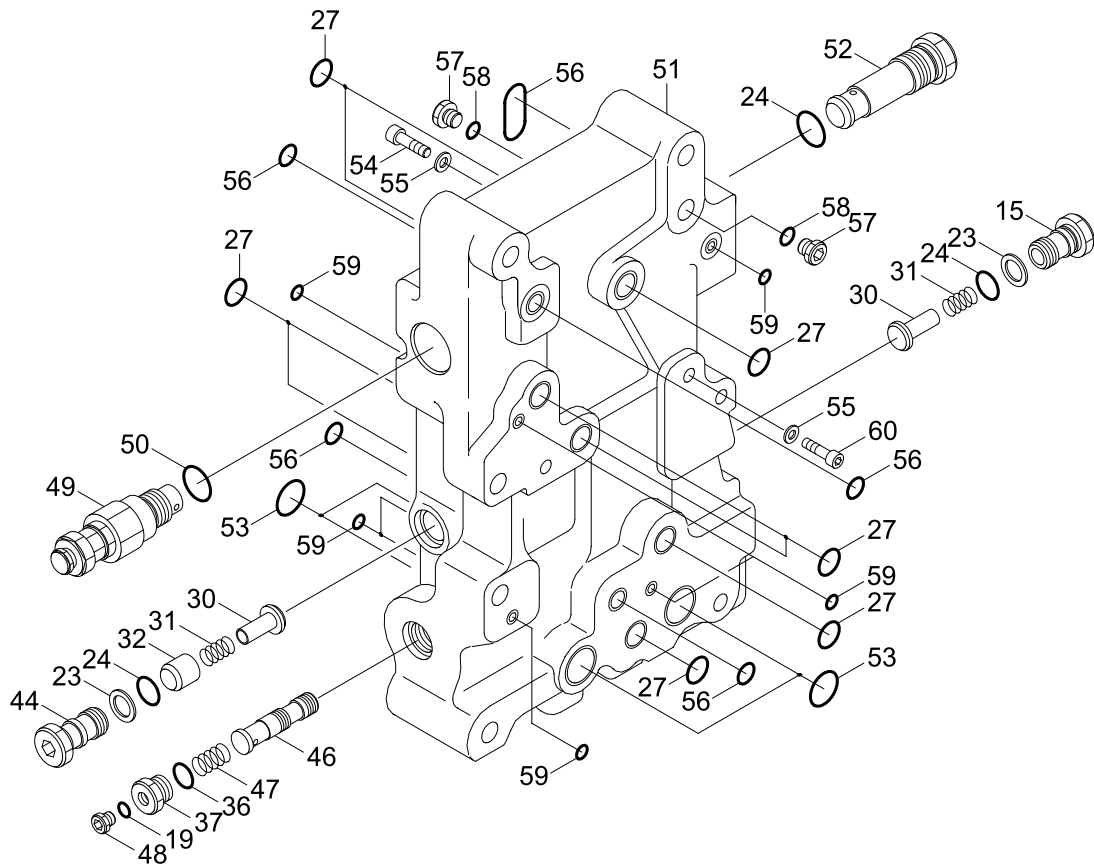

36078MC03

15	Cap	37	Cap	53	O-ring
19	O-ring	44	Cap	54	Socket bolt
23	Back up ring	46	Spool	55	Washer
24	O-ring	47	Spring	56	O-ring
27	O-ring	48	Cap	57	Cap
30	Check	49	Main relief valve	58	O-ring
31	Spring	50	O-ring	59	O-ring
32	Check	51	Manifold	60	Socket bolt
36	O-ring	52	Logic check valve		

STRUCTURE (3/3)

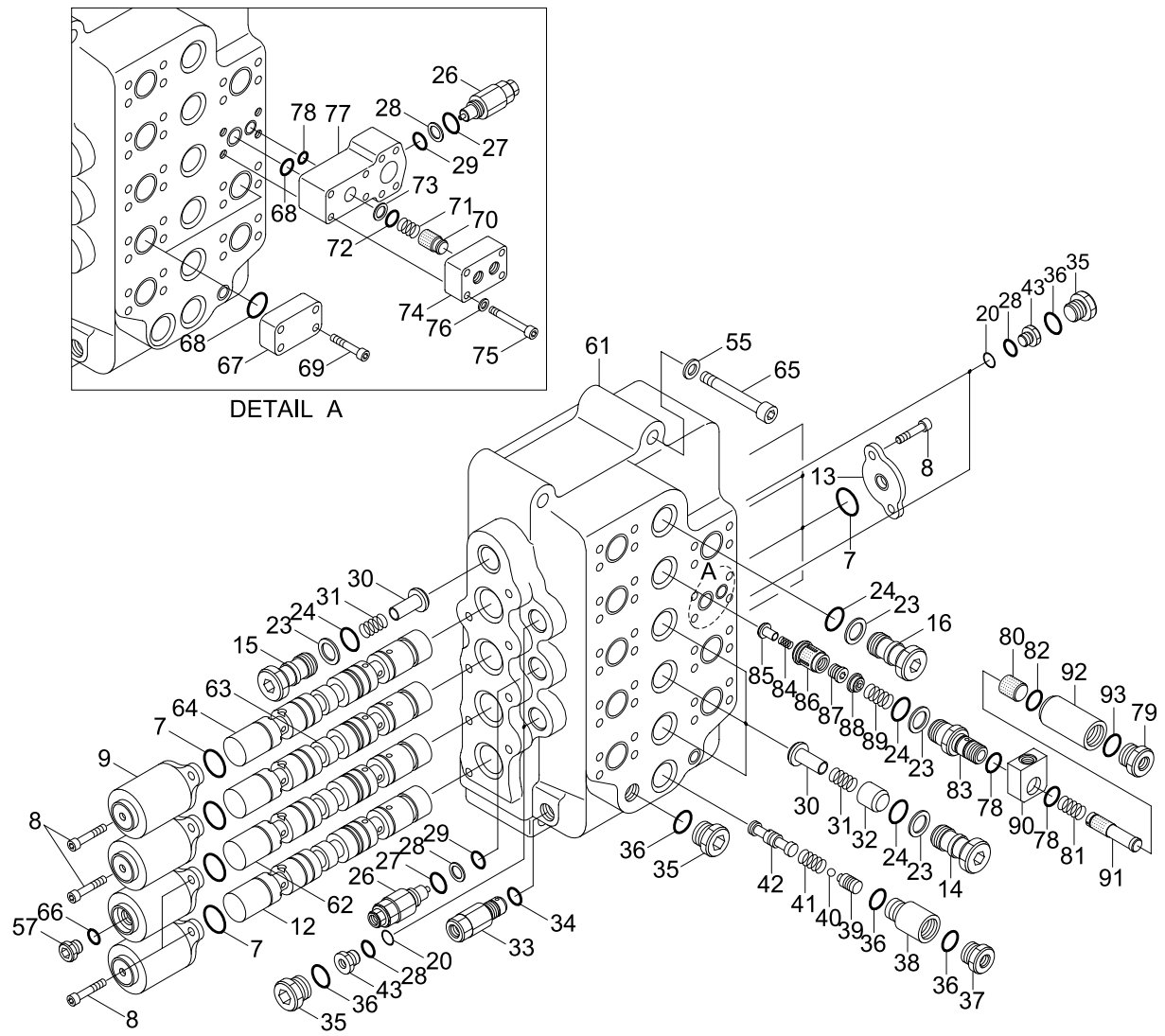

36078MC04

7	O-ring	31	Spring	62	Option plunger assy	78	O-ring
8	Socket bolt	32	Check	63	Arm plunger assy	79	Cap
9	Cover	33	Foot relief valve	64	Swing plunger assy	80	Piston
12	Travel plunger assy	34	O-ring	65	Socket bolt	81	Spring
13	Cover	35	Cap	66	O-ring	82	O-ring
14	Cap	36	O-ring	67	Flange	83	Sleeve
15	Cap	37	Cap	68	O-ring	84	Spring
16	Cap	38	Cap	69	Socket bolt	85	Check
20	O-ring	39	Piston	70	Poppet	86	Poppet
23	Back up ring	40	Steel ball	71	Spring	87	Cap
24	O-ring	41	Spring	72	O-ring	88	Spring guide
26	Overload relief valve	42	Spool	73	Back up ring	89	Spring
27	O-ring	43	Plug	74	Cover assy	90	Union
28	Back up ring	55	Washer	75	Socket bolt	91	Piston
29	O-ring	57	Cap	76	Lock washer	92	Cap
30	Check	61	Housing	77	Manifold	93	O-ring

3. DISASSEMBLY AND ASSEMBLY

1) GENERAL PRECAUTIONS

(1) Disassembly

- ① Handle the components carefully not to drop them or bump them with each other as they are made with precision.
- ② Do not force the work by hitting or twisting as burred or damaged component may not be assembled or result in oil leakage or low performance.
- ③ When disassembled, tag the components for identification so that they can be re-assembled correctly.
- ④ Once disassembled, O-rings and backup rings are usually not to be used again. (Remove them using a wire with its end made like a shoehorn. Be careful not to damage the slot.)
- ⑤ If the components are left disassembled or half-disassembled, they may get rust from moisture or dust. If the work has to be interrupted, take measures to prevent rust and dust.

(2) Assembly

- ① Take the same precautions as for disassembly.
- ② When assembling the components, remove any metal chips or foreign objects and check them for any burrs or dents. Remove burrs and dents with oil-stone, if any.
- ③ O-rings and backup rings are to be replaced with new ones, as a rule.
- ④ When installing O-rings and backup rings, be careful not to damage them. (Apply a little amount of grease for smoothness.)
- ⑤ Tighten the bolts and caps with specified torque.

2) TOOLS

Before disassembling the control valve, prepare the following tools beforehand.

Name of tool	Quantity	Size(mm)
Vice mounted on bench(Soft jaws)	1 unit	
Hexagon wrench	Each 1 piece	6, 8, 10, 12, 14 and 17
Socket wrench	Each 1 piece	19, 30, 36, 41 and 46

3) MOUNTING AND DISMOUNTING VALVES

(1) Disassembly

4 spool valve can be removed by loosening socket bolts (1,2), while 3 spool valve can be removed by loosening socket bolts (3,4).

(2) Assembly

- ※ Valves should be mounted after making sure that all O-rings and cap are placed on the assembling faces and check spacer is placed on assembling faces of 3-plunger valve.
- Place the valve assembly on plane surface and assemble 3 spool valve to manifold and then assemble 4 spool valve.
- Tighten the socket bolts at specified torque after making sure that the assembly is leveled.
- Tightening torque : 25 kgf · m (181 lbf · ft)

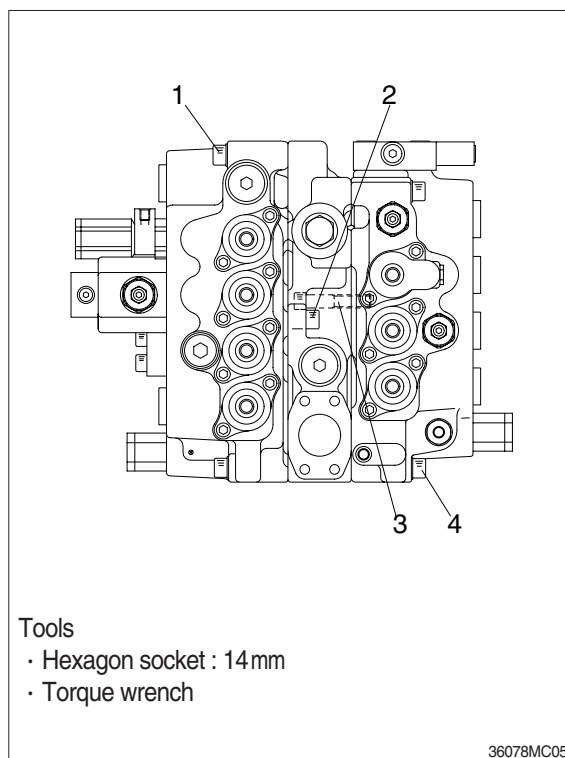

4) OPERATING SECTION OF HYDRAULIC PACK

(1) Loosen socket bolt (1) to remove cover (2).

※ Install cover (2) after making sure that O-ring is placed on the edge of the valve hole.

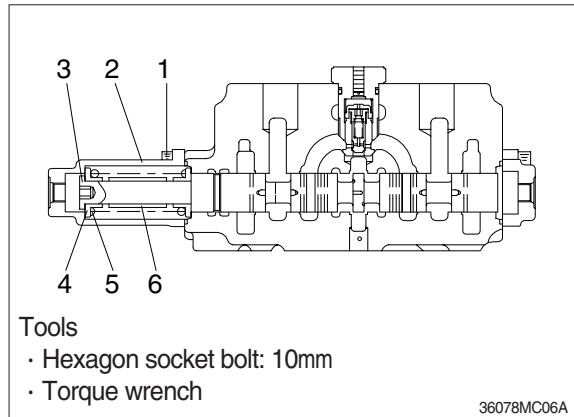

(2) Pull the plunger out while holding the spring.

※ Do not pull it out violently, but draw it out gently while making sure of its contact with housing hole.

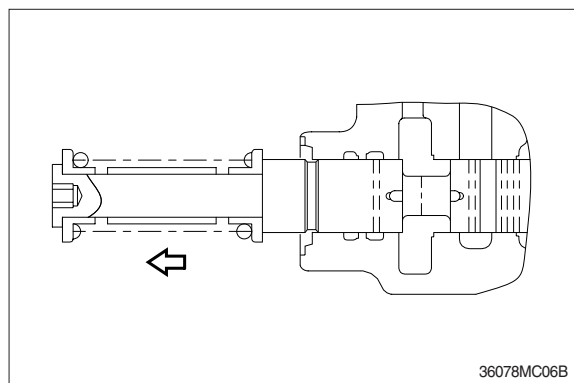

(3) Place the plunger between holders and loosen plunger cap (3) by using a vise.

• Plunger cap

Hexagon socket : 10 mm

Tightening torque : 10 kgf · m(72.3 lbf · ft)

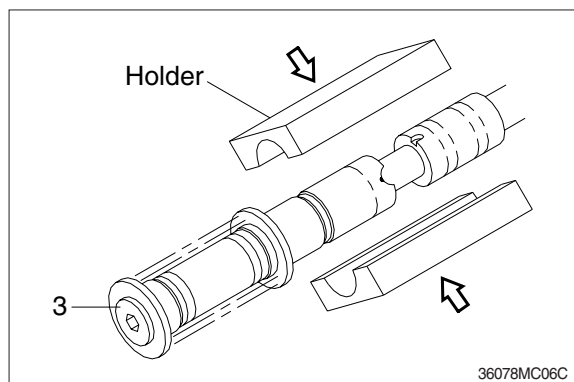

(4) Remove plunger cap (3), guide (4), sleeve (5) and spring (6) in this order.

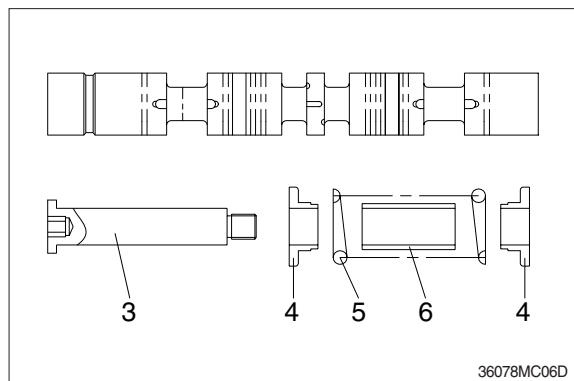

(5) Arm plunger only (Remove check)

Remove cap (7) and disassemble spring (8) and check (9).

- Plunger cap

Hexagon socket : 10 mm

Tightening torque : 10 kgf · m (72.3 lbf · ft)

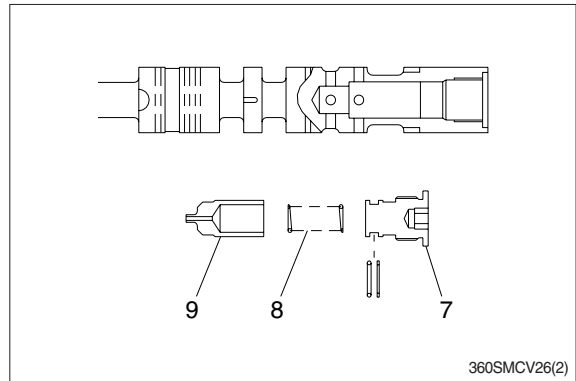

5) OVERLOAD RELIEF ASSEMBLY

Relief assembly is assembled into a single block as a cartridge. Do not disassemble the relief assembly as a rule.

- (1) Loosen the relief sleeve(1) and remove the cartridge.

Tightening torque : 10 kgf · m (72.3 lbf · ft)

- ※ Record original position for reassembly.

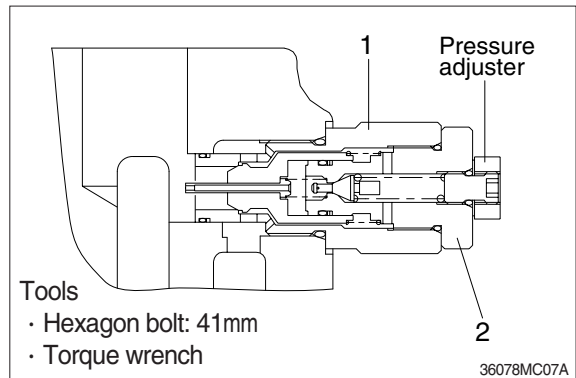

- (2) Loosen the relief seat(2) and remove the sub assembly.

Tightening torque : 10 kgf · m (72.3 lbf · ft)

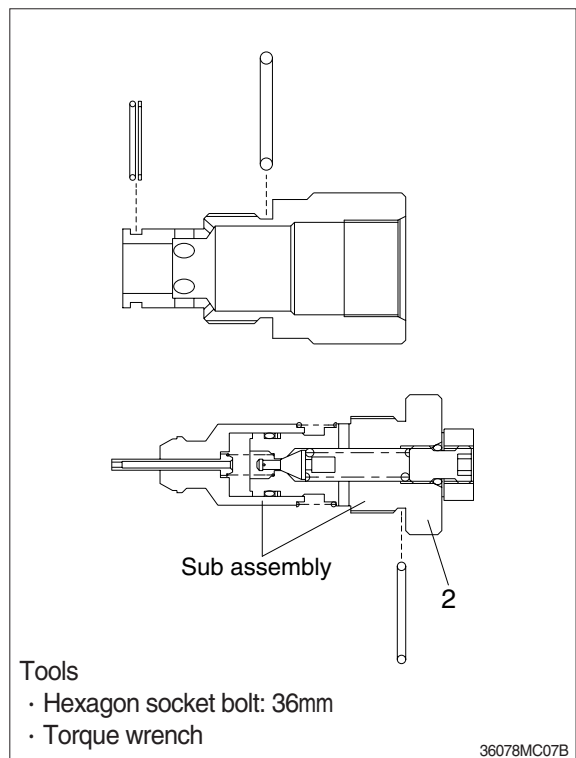

(3) Pull out the poppet(3) and take off the piston(4) and springs(5,6).

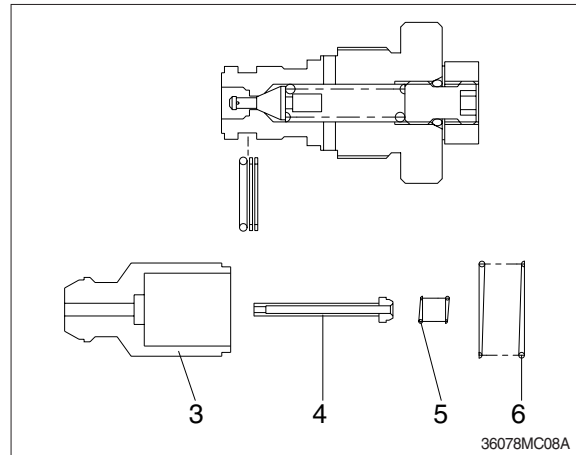

6) COVER ASSEMBLY(BOOM PLUNGER)

(1) Loosen socket bolt(1) to remove cover(2).
 ※ Install cover(2) after making sure that O-ring is placed on the edge of the valve hole.

Tightening torque : 10kgf · m (72.3lbf · ft)

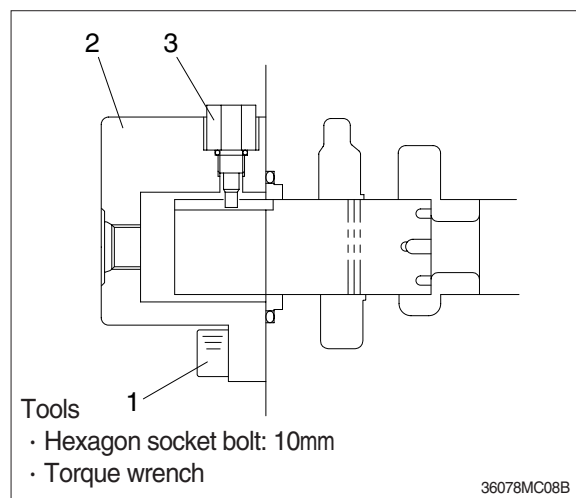

(2) Remove plug(3).

Tightening torque : 8kgf · m (57.9lbf · ft)

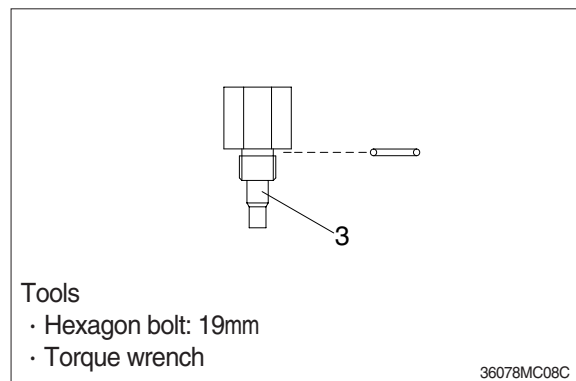

7) CENTER BYPASS VALVE ASSEMBLY

(1) Remove cap(1).

Tightening torque : 10kgf · m (72.3lbf · ft)

※ Record original position for reassembly.

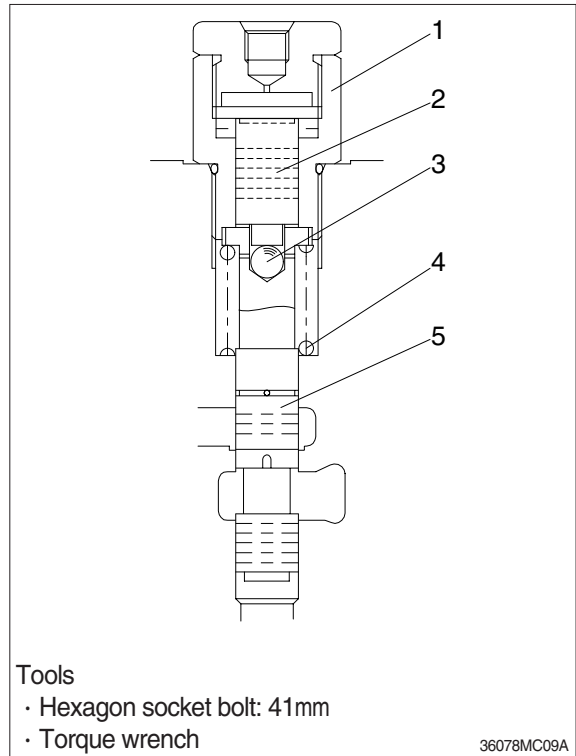

(2) Remove piston(2), steel ball(3), spool(5) and spring(4).

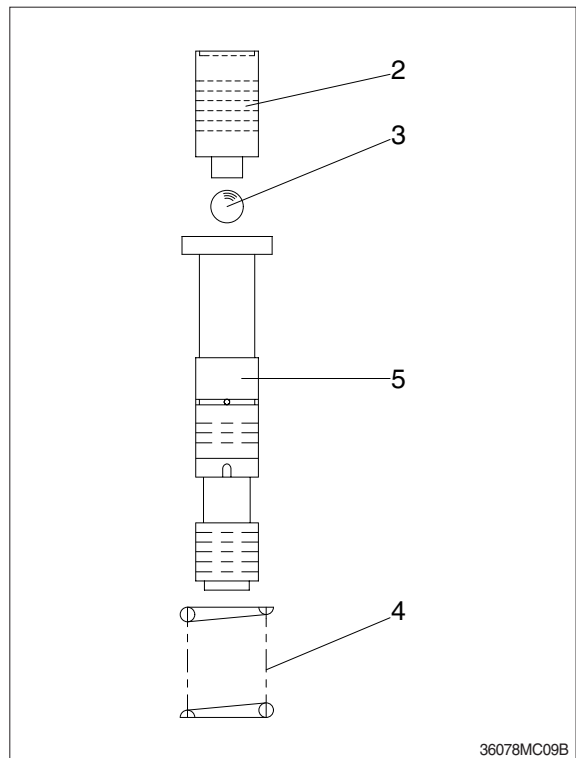

8) LOAD CHECK ASSEMBLY

(1) Remove cap(1).

Tightening torque : 35kgf · m (253.2lbf · ft)

※ Record original position of arm summation cap for reassembly.

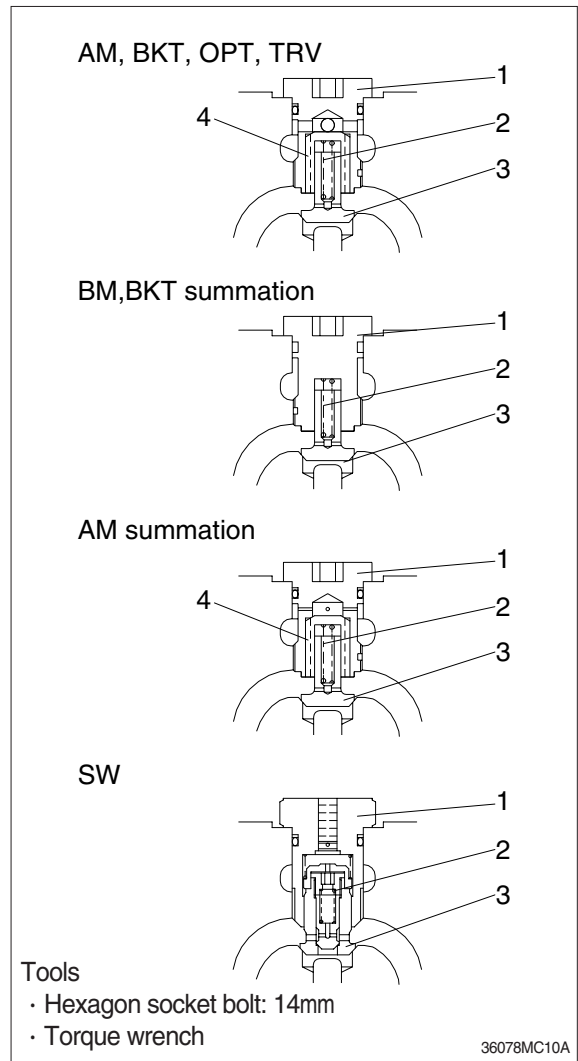

(2) Remove check valve(4), spring(2) and check valve(3).

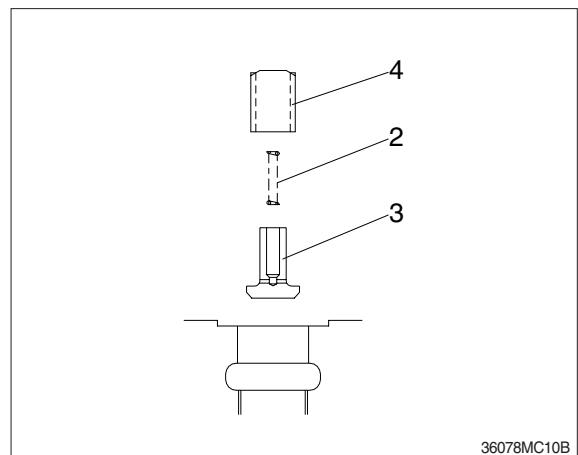

9) BOOM PRIORITY ASSEMBLY

- (1) Remove cap(1), piston(2), spring(3) and union(4).

Tightening torque : 10kgf · m (72.3lbf · ft)

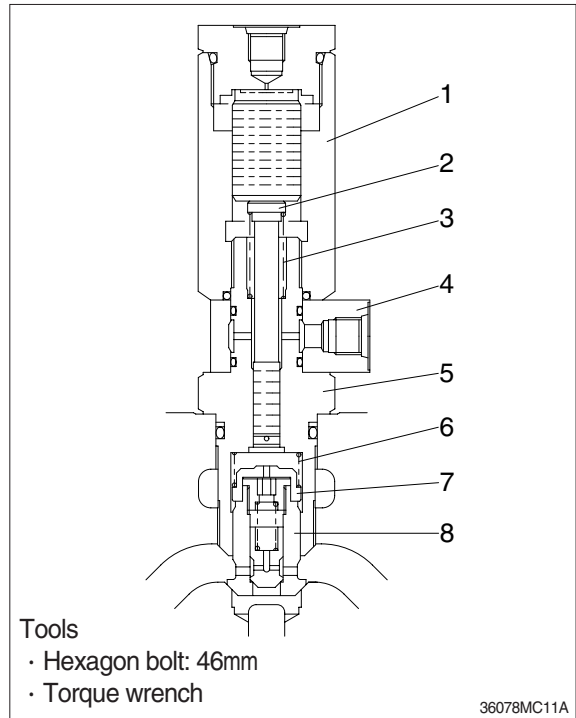

- (2) Remove sleeve(5), spring(6), spring guide(7) and poppet sub assembly(8).

Tightening torque : 35kgf · m (253.2lbf · ft)

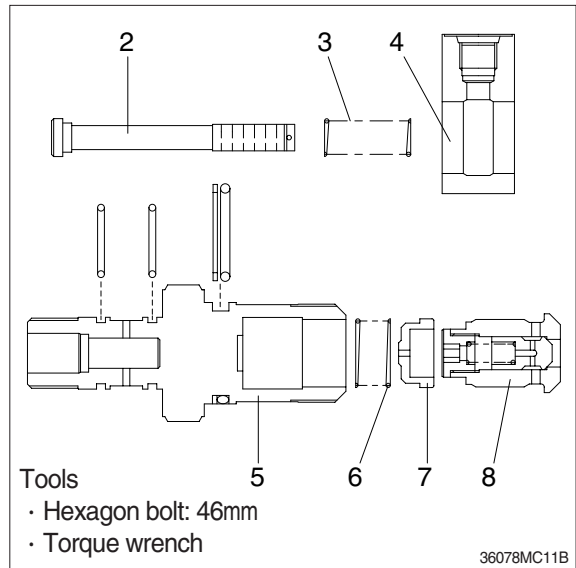

- (3) Place the poppet sub assembly(8) between holders and cap(9) by using a vise.

Tightening torque : 3.5kgf · m (25.3lbf · ft)

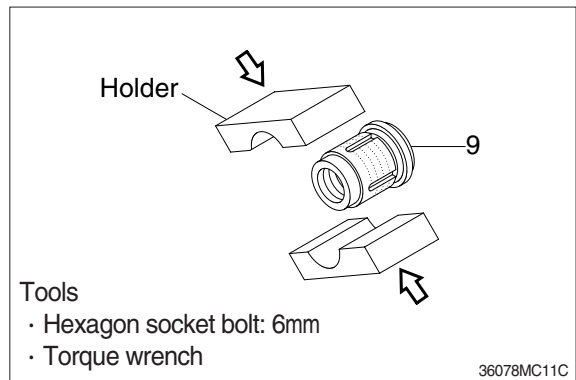

(4) Remove cap(9).

Take off spring(10), check valve(11) and poppet(12).

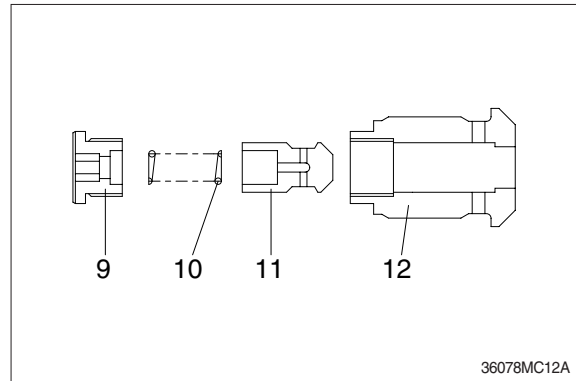

10) ARM LOAD HOLDING VALVE

(1) Loosen socket bolt(1) to remove cover(2) from housing.

Tightening torque : 18kgf · m (130.2lbf · ft)

※ Install cover(2) after making sure that O-ring is placed on the edge of the bore.

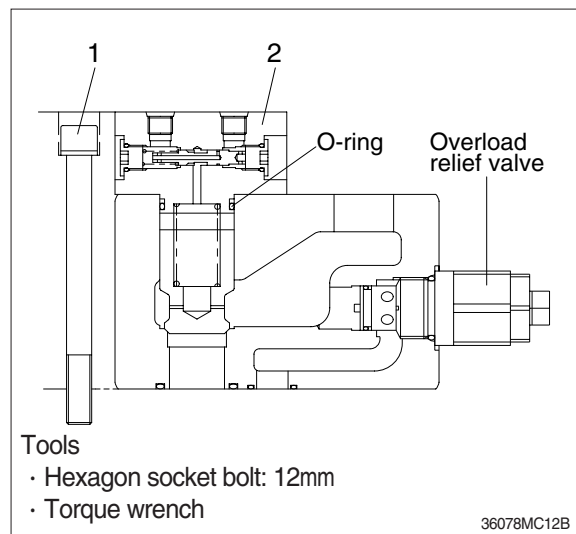

(2) Remove spring(3) and poppet(4).

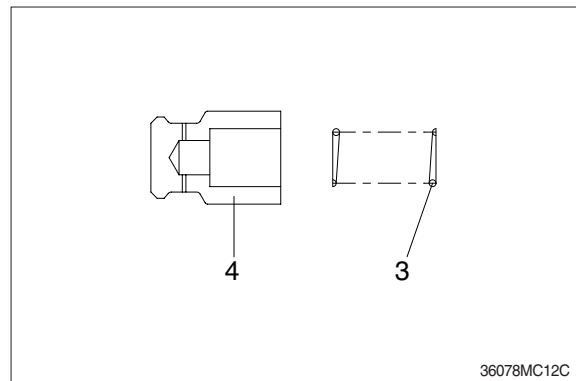

- (3) Remove cap(5).
 Take off spring(6) and spool(7).
 Tightening torque : 3kgf · m (21.7lbf · ft)

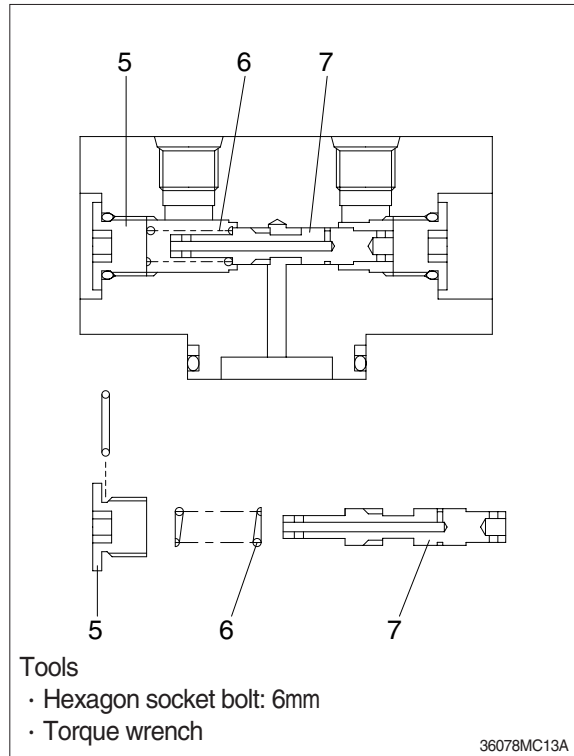

11) LOGIC VALVE(FOR BOOM SUMMATION)

- (1) Remove cap(1).
 Take off piston(2) and spring(3).
 Tightening torque : 10kgf · m (72.3lbf · ft)

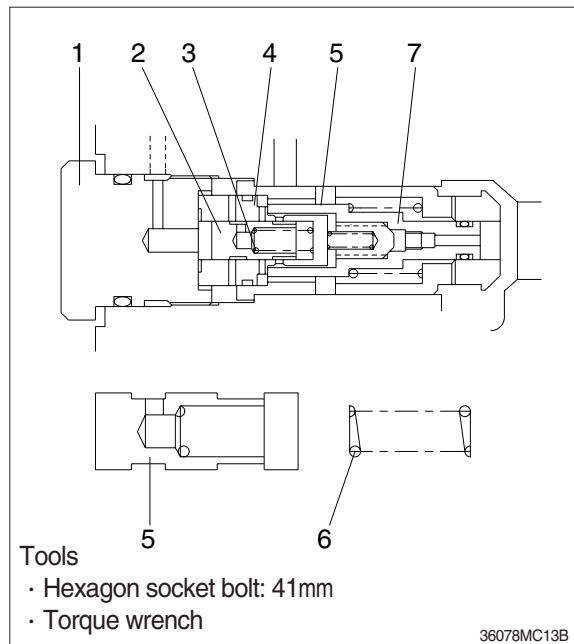

- (2) Pull out sleeve(4) by inner-threaded special tool.
Take off spring(5) and check valve(6).

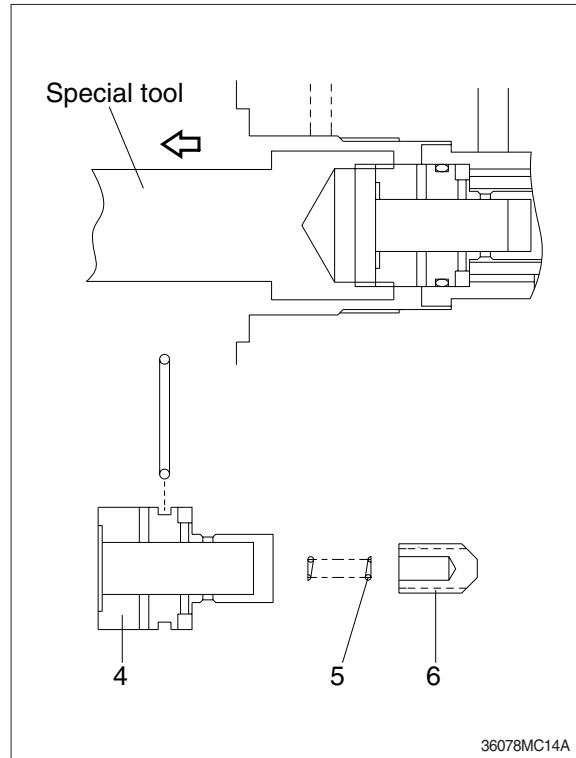

- (3) Pull out sleeve(7) by threaded round bar.
Take off spring(8) and check(9).

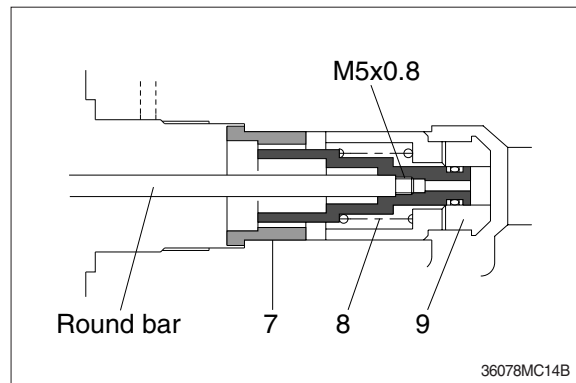

12) MAIN RELIEF ASSEMBLY

Relief assy is assembled into a single block as a cartridge. Do not disassemble the relief assembly as a rule.

- (1) Loosen the hexagon nut(2) with a holding adjust screw(1).
- (2) Loosen the hexagon nut(3) with a holding cap(4).
- (3) Loosen the cap(4) and remove the cartridge.
- (4) Pull out the sleeve(6) and take off the main piston(7), spring(8) and orifice(9).
 - ※ Can't remove the pilot seat from the cap(4), because it was locked at the cap.
- (5) Loosen each screw and remove.

Item No.	Name	Socket
1	Adjust screw	22mm
2	Hexagon nut	30mm
3	Hexagon nut	30mm
4	Cap	41mm
6	Sleeve	27mm

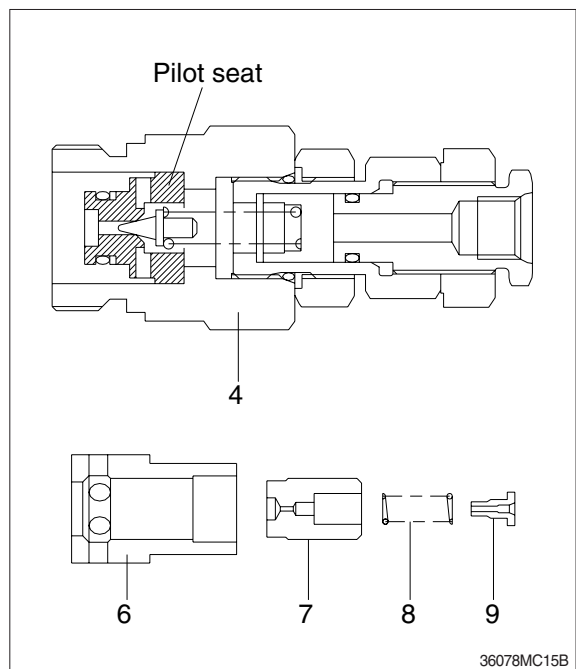
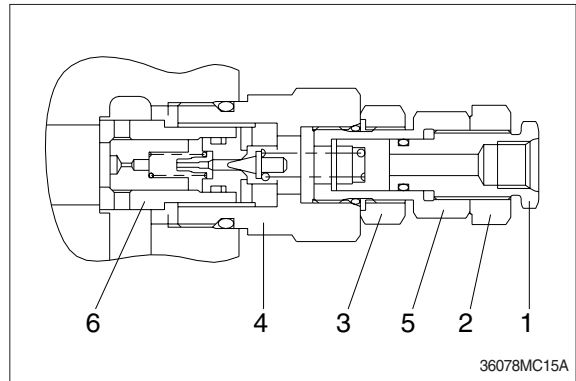

13) FOOT RELIEF ASSEMBLY

- (1) Loosen cap(1) and remove poppet(2).
Tightening torque : 6kgf · m (43.4lbf · ft)

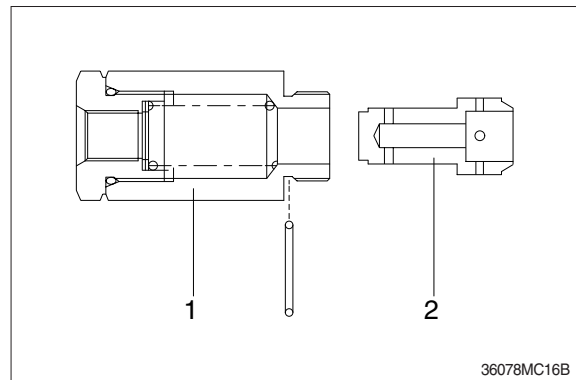
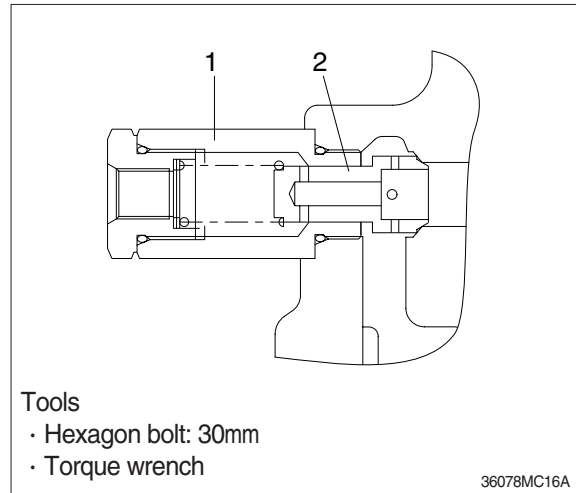

- (2) Remove cap(3) and take off shim(4) and spring(5).

Tightening torque : 6kgf · m (43.4lbf · ft)

※ Make sure adjust shim quantity.

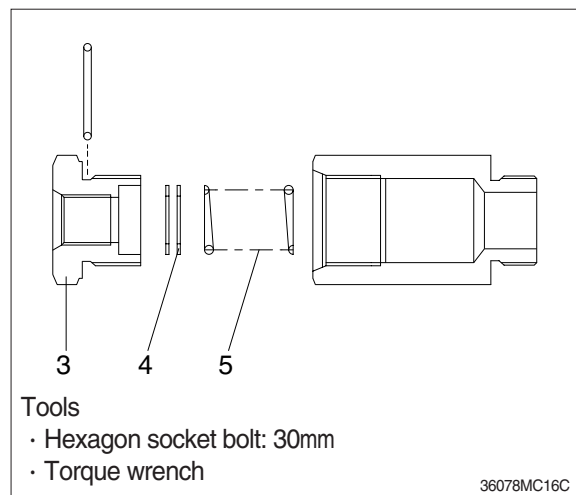

14) BOOM LOAD HOLDING VALVE

(1) Basic unit

- ① Loosen socket bolt (1) to remove cover assembly (2).

Tightening torque : 25 kgf · m
(180.8 lbf · ft)

- ※ Install cover assembly (2) after making sure that O-ring is placed on the edge of the valve hole.

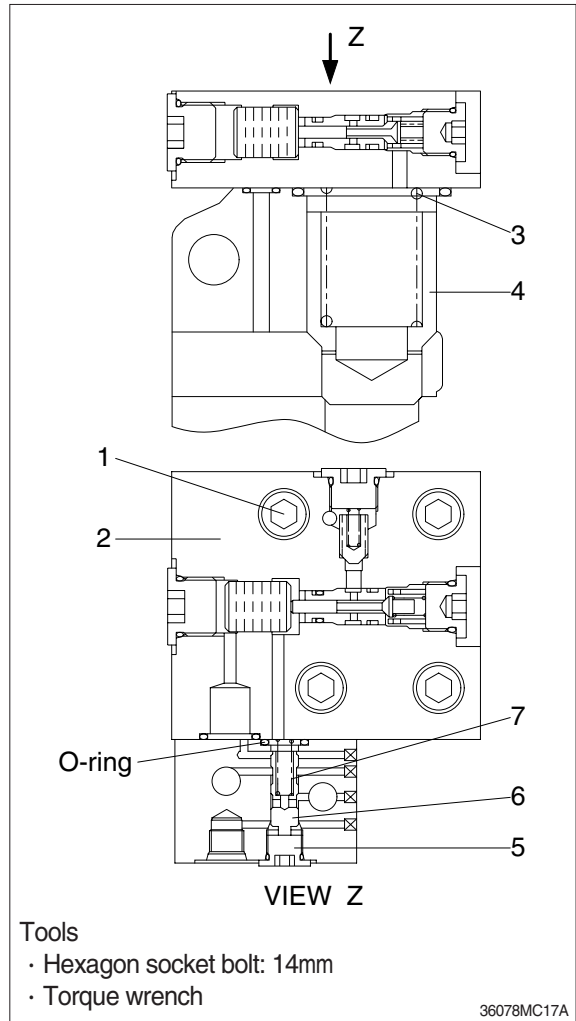

- ② Take off spring (3) and check valve (4).

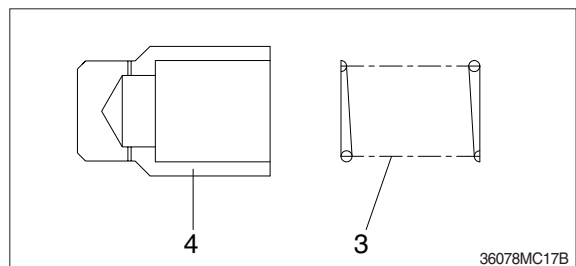

(2) Selector unit

- ① Remove the cap(5), piston(6) and spring(7).

Tightening torque : 3kgf · m (21.7lbf · ft)

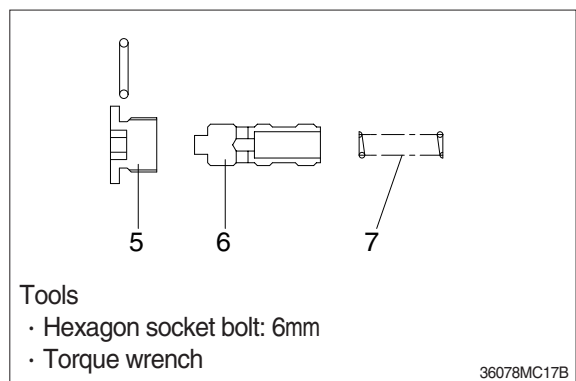

(3) Cover assembly

- ① Remove cap (8).

Take off spring (9) and check valve (10).

Tightening torque : 5 kgf · m(36.2lbf · ft)

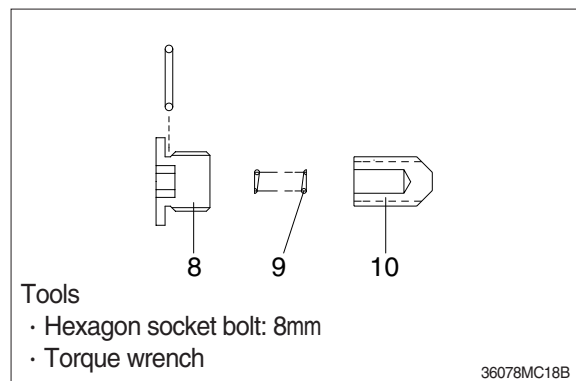
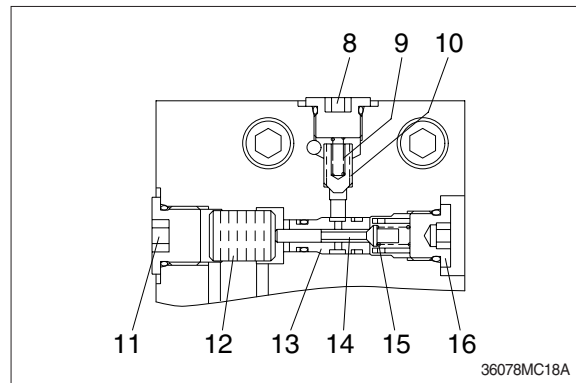

- ② Remove cap (11) and take off piston(12).

Tightening torque : 6kgf · m(43.4lbf · ft)

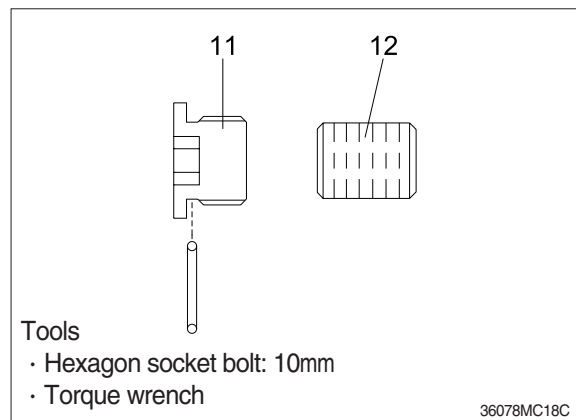

- ③ Remove cap (16).

Take off spring(15) and poppet(14).

Tightening torque : 5kgf · m(36.2lbf · ft)

- ④ Push sleeve (13) out with a rod or the like through the hole of cap (11).

※ Be careful not to damage the guideway of the sleeve.

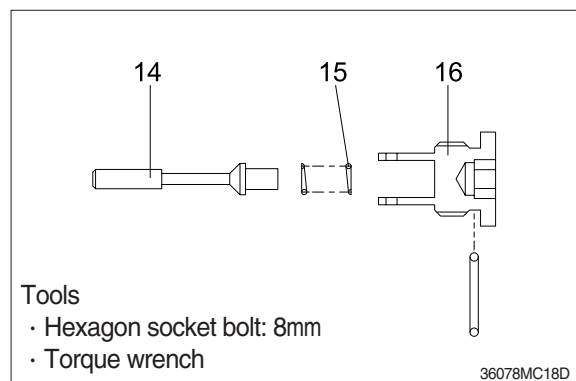

15) TRAVEL STRAIGHT VALVE

- (1) Remove cap(1).
Take off spool(3) and spring(2).
Tightening torque : 10kgf · m (72.3lbf · ft)

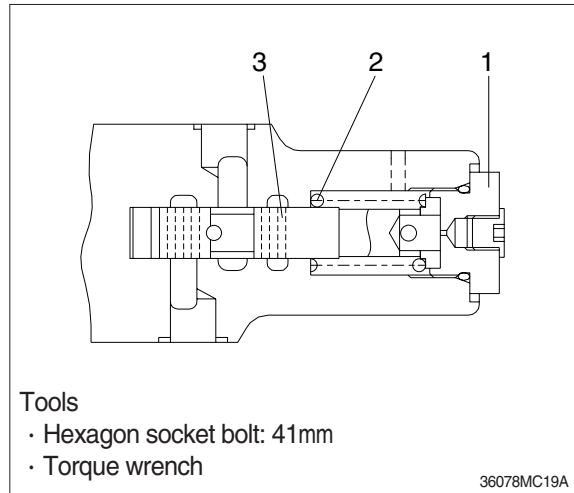

16) OVER LOAD PLUG(OPTION)

- (1) Remove cap(1).
Take off spool(2) by M8 tap.

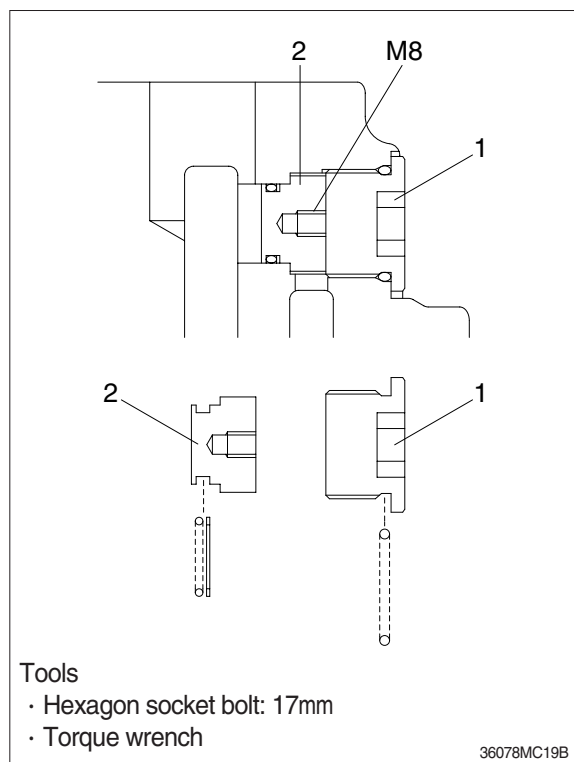

- (2) Install overload relief valve(3) to valve hole.
Tightening torque : 10kgf · m (72.3lbf · ft)

