

GROUP 4 HYDRAULIC SYSTEM

HYDRAULIC COMPONENTS MOUNTING 1

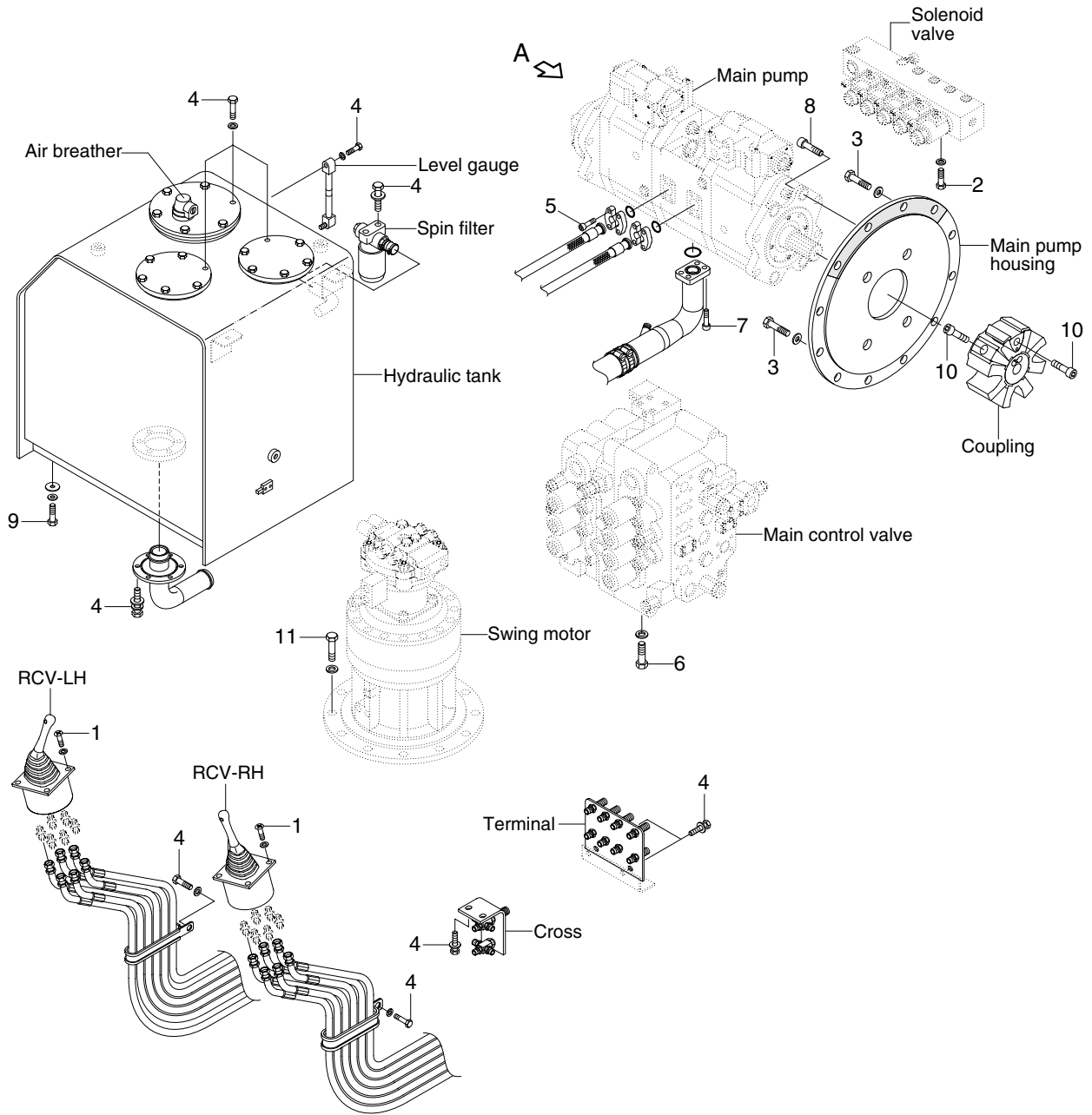

37079CM05

· Tightening torque

Item	Size	kgf · m	lbf · ft
1	M 6×1.0	1.05±0.2	7.6±1.45
2	M 8×1.25	2.5±0.5	18.1±3.6
3	M10×1.5	4.8±0.3	34.7±2.1
4	M10×1.5	6.9±1.4	49.9±10.1
5	M12×1.75	14.7±2.2	106±15.9
6	M16×2.0	19.5±1.3	141±9.4

Item	Size	kgf · m	lbf · ft
7	M16×2.0	35.6±7.1	257±51
8	M20×2.5	42±4.5	304±32.5
9	M20×2.5	46±5.0	333±36
10	M20×2.5	46.5±2.5	336±18.1
11	M24×3.0	100±15	723±108
-	-	-	-

HYDRAULIC COMPONENTS MOUNTING 2

Double acting attachment piping

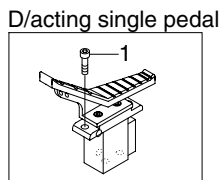
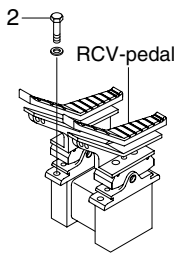
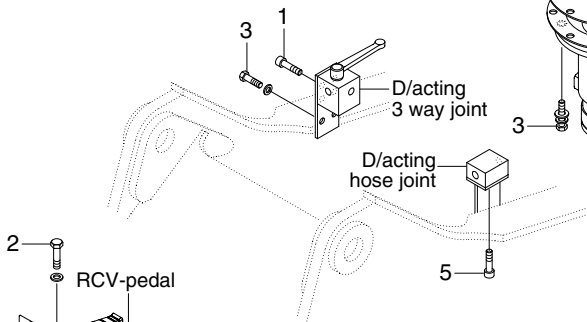
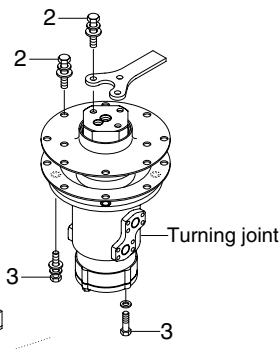
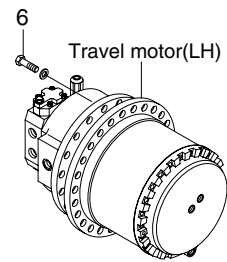
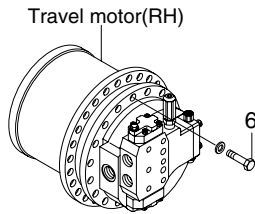
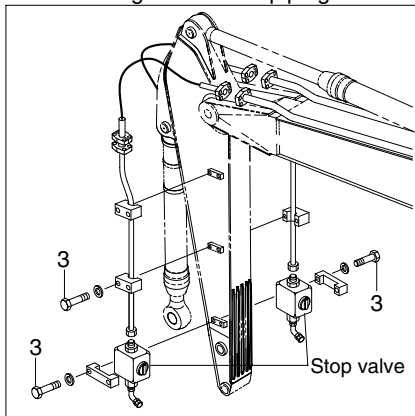

Boom safety lock system

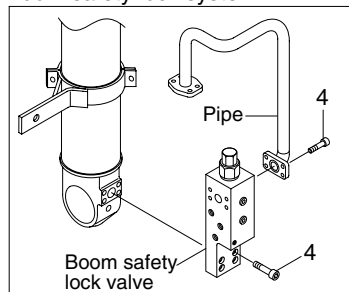

Arm safety lock system

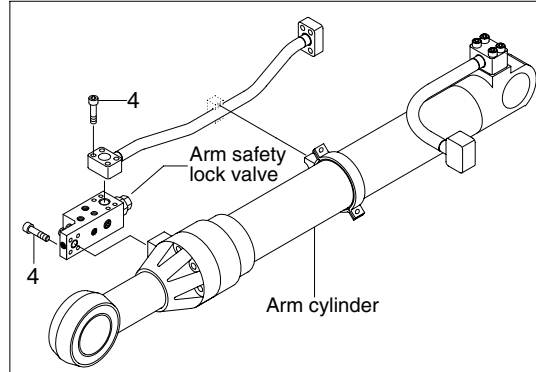

30079CM06

· Tightening torque

Item	Size	kgf · m	lbf · ft
1	M 8×1.25	4.05±0.8	29.3±5.8
2	M10×1.5	6.9±1.4	49.9±10.1
3	M12×1.75	12.8±3.0	92.6±21.7

Item	Size	kgf · m	lbf · ft
4	M12×1.75	9.4±1.0	68.0±7.2
5	M12×1.75	14.7±2.2	106±15.9
6	M20×2.5	43.8±4.0	317±29

HYDRAULIC COMPONENTS MOUNTING 3

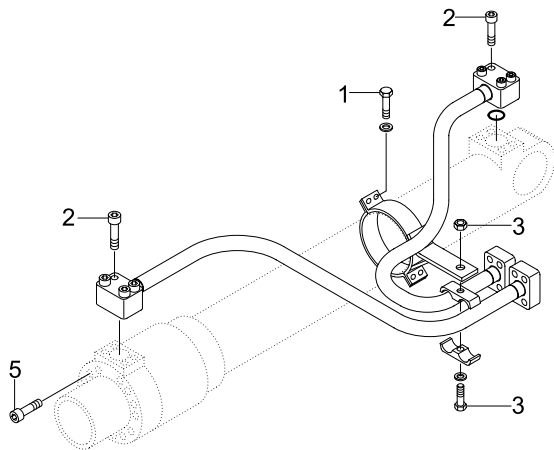

BOOM CYLINDER

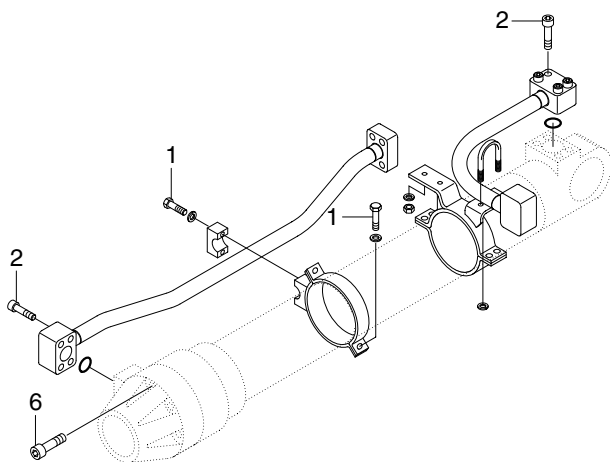
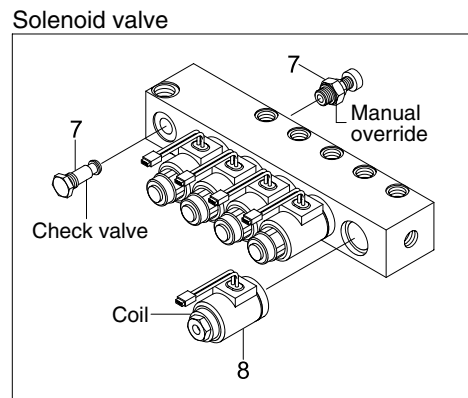

ARM CYLINDER

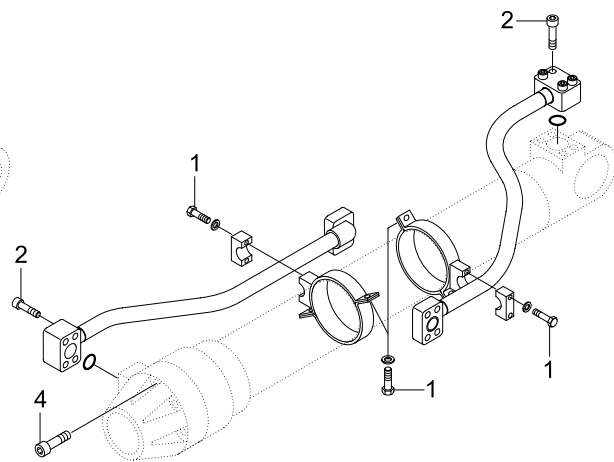

BUCKET CYLINDER

37079CM07

· Tightening torque

Item	Size	kgf · m	lbf · ft
1	M12×1.75	5.5±0.6	39.8±4.3
2	M12×1.75	9.4±1.0	68.0±7.2
3	M14×2.0	9.0±1.0	65±7.2
4	M24×3.0	79±8.0	571±57.9

Item	Size	kgf · m	lbf · ft
5	M20×2.5	46±5.0	333±36.2
6	M27×3.0	116±12	839±86.8
7	M22×2.5	4.1	29.6
8	M27×3.0	5.1	36.9