

GROUP 2 ENGINE SYSTEM

ENGINE AND ACCESSORIES MOUNTING

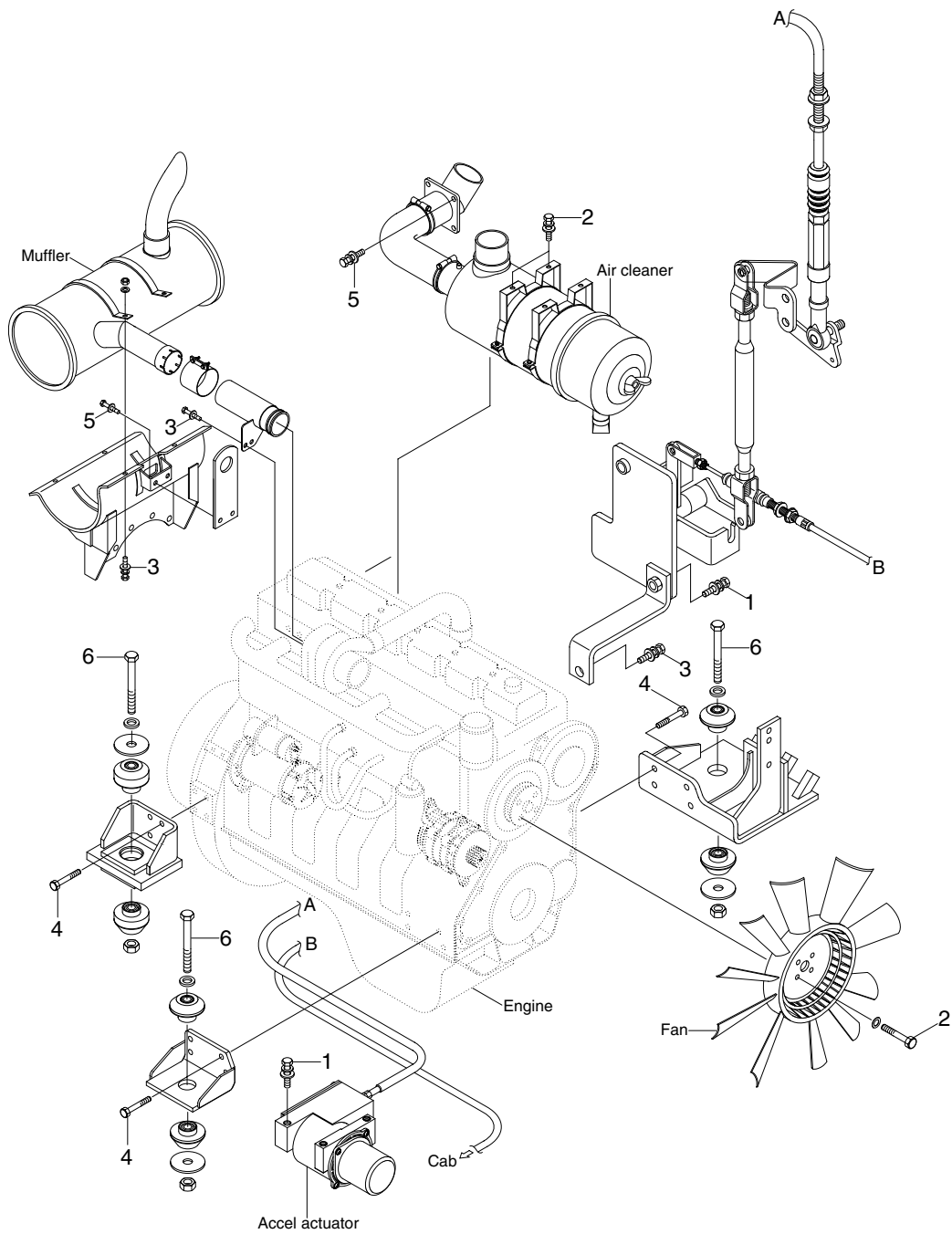

37079CM01

· Tightening torque

Item	Size	kgf · m	lbf · ft
1	M 8×1.5	2.5±0.5	18.1±3.6
2	M10×1.5	4.4±0.9	31.8±6.5
3	M10×1.5	6.9±1.4	49.9±10.1

Item	Size	kgf · m	lbf · ft
4	M14×2.0	14.5±2.5	105±18
5	M12×1.75	12.8±3.0	92.6±21.7
6	M22×2.5	48±2.0	347±14.5

COOLING SYSTEM AND FUEL TANK MOUNTING

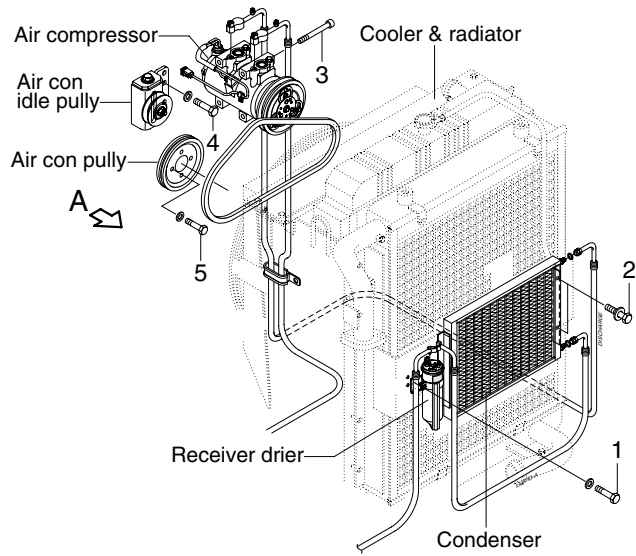
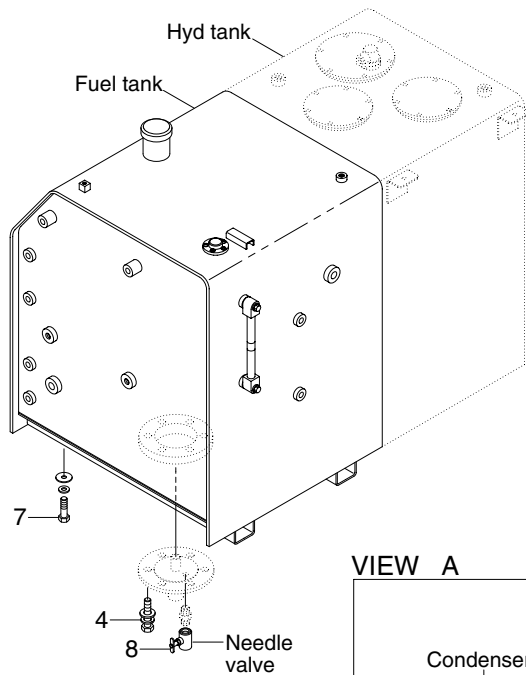

VIEW A

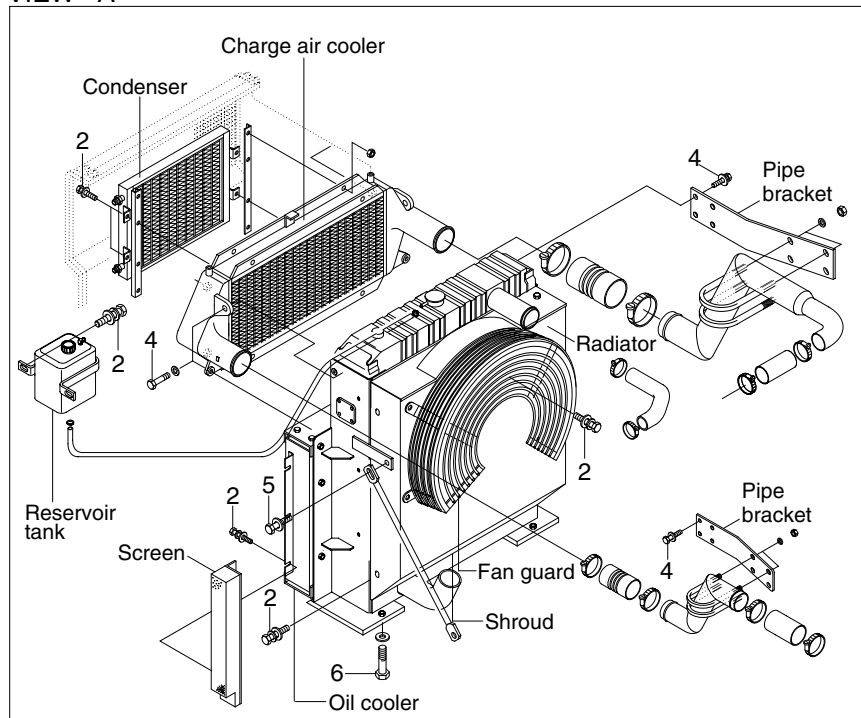

37079CM02

· Tightening torque

Item	Size	kgf · m	lbf · ft
1	M 6×1.0	1.05±0.2	7.6±1.45
2	M 8×1.25	2.5±0.5	18.1±3.6
3	M 8×1.25	4.05±0.8	29.3±5.8
4	M10×1.5	6.9±1.4	49.9±10.1

Item	Size	kgf · m	lbf · ft
5	M12×1.75	12.8±3.0	92.6±21.7
6	M16×2.0	22±1.0	159±7.2
7	M20×2.5	46±5.0	333±36
8	-	2.3±0.6	16.6±4.3