

## GROUP 3 TRACK AND WORK EQUIPMENT

### 1. TRACK

#### 1) TRACK ROLLER

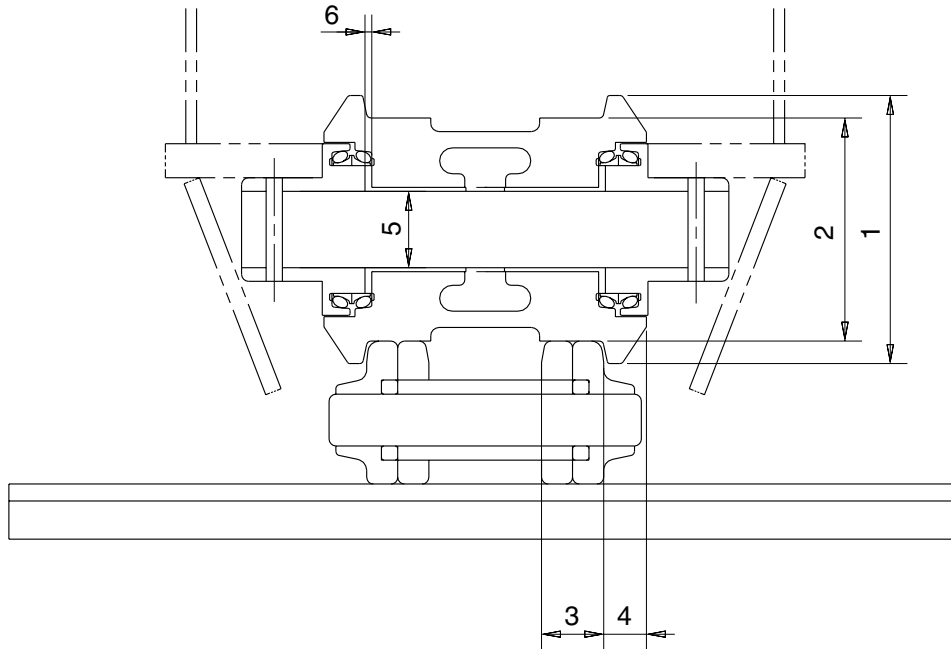

21037MS01

Unit : mm

No.	Check item	Criteria				Remedy
		Standard size		Repair limit		
1	Outside diameter of flange	Standard size		Repair limit		Rebuild or replace
		ø 250		-		
2	Outside diameter of tread	ø 200		ø 188		
3	Width of tread	54.6		60.6		
4	Width of flange	34.4		-		
5	Clearance between shaft and bushing	Standard size & tolerance		Standard clearance	Clearance limit	Replace bushing
		Shaft	Hole			
		ø 85 <sup>-0.25</sup> <sub>-0.35</sub>	ø 85 <sup>+0.176</sup> <sub>+0.029</sub>	0.279 to 0.526	2.0	
6	Side clearance of roller (Both side)	Standard clearance		Clearance limit		Replace
		0.12~1.3		2.0		

## 2) CARRIER ROLLER

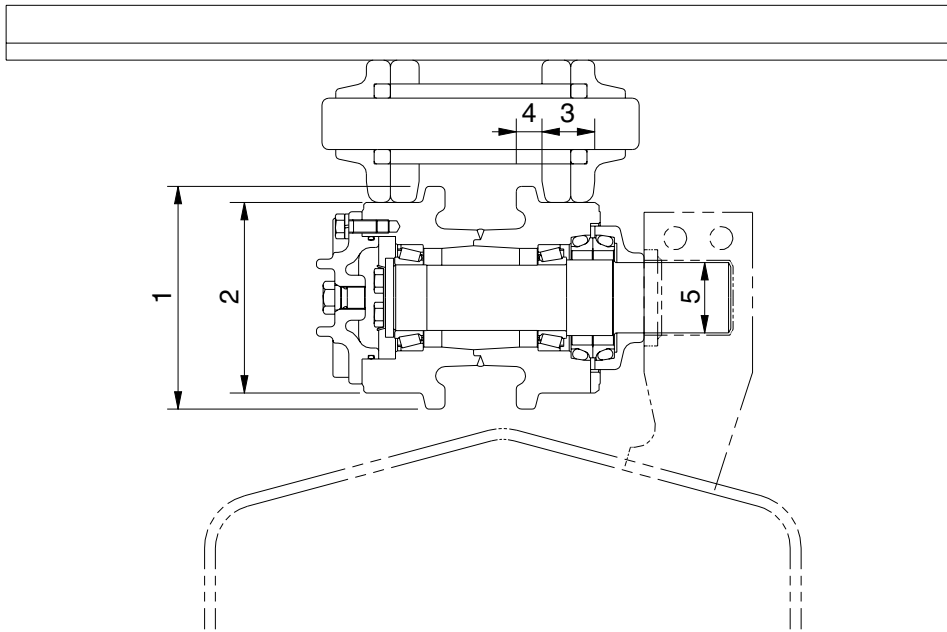

21037MS02

Unit : mm

No.	Check item	Criteria			Remedy
		Standard size		Repair limit	
1	Outside diameter of flange	ø 200		-	Rebuild or replace
2	Outside diameter of tread	ø 191		ø 181	
3	Width of tread	51		56	
4	Width of flange	20		-	
5	Clearance between shaft and support	Standard size & tolerance		Standard clearance	Clearance limit
		Shaft	Hole		
		ø 57.15 $\begin{matrix} 0 \\ -0.1 \end{matrix}$	ø 57.15 $\begin{matrix} +0.3 \\ +0.1 \end{matrix}$	0.1 to 0.4	1.2

### 3) IDLER

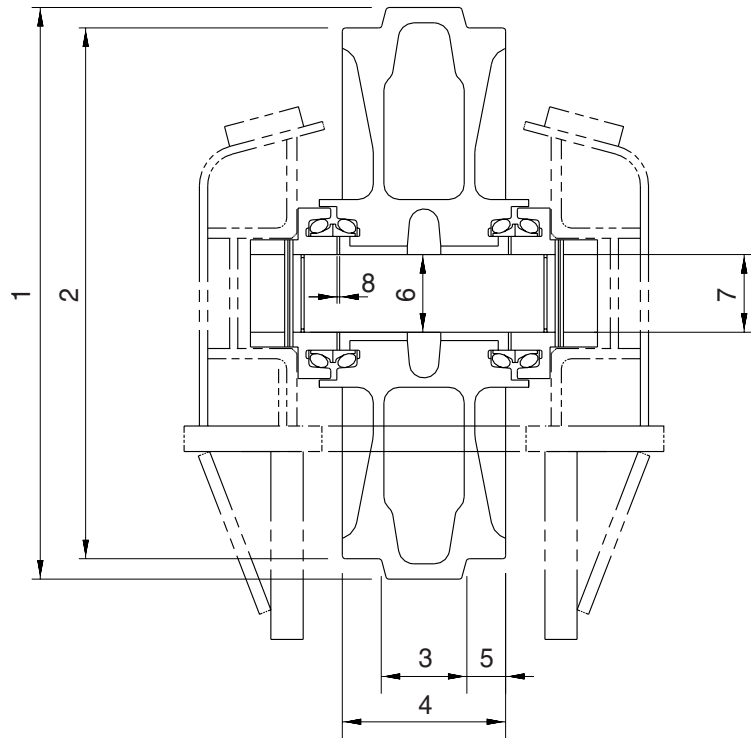

21037MS03

Unit : mm

No.	Check item	Criteria		Remedy		
		Standard size	Repair limit			
1	Outside diameter of protrusion	Standard size	Repair limit	Rebuild or replace		
		ø 646	-			
2	Outside diameter of tread	ø 594	ø 580			
3	Width of protrusion	102	-			
4	Total width	203	-			
5	Width of tread	50.5	57.5			
6	Clearance between shaft and bushing	Standard size & tolerance		Standard clearance	Clearance limit	Replace bushing
		Shaft	Hole			
		ø 85 $\begin{matrix} 0 \\ -0.035 \end{matrix}$	ø 85.35 $\begin{matrix} +0.05 \\ 0 \end{matrix}$	0.35 to 0.435	2.0	
7	Clearance between shaft and support	ø 85 $\begin{matrix} 0 \\ -0.035 \end{matrix}$	ø 85 $\begin{matrix} +0.09 \\ +0.036 \end{matrix}$	0.036 to 0.125	1.2	Replace
8	Side clearance of idler (Both side)	Standard clearance		Clearance limit		Replace
		0.25 to 1.2		2.0		

#### 4) TRACK

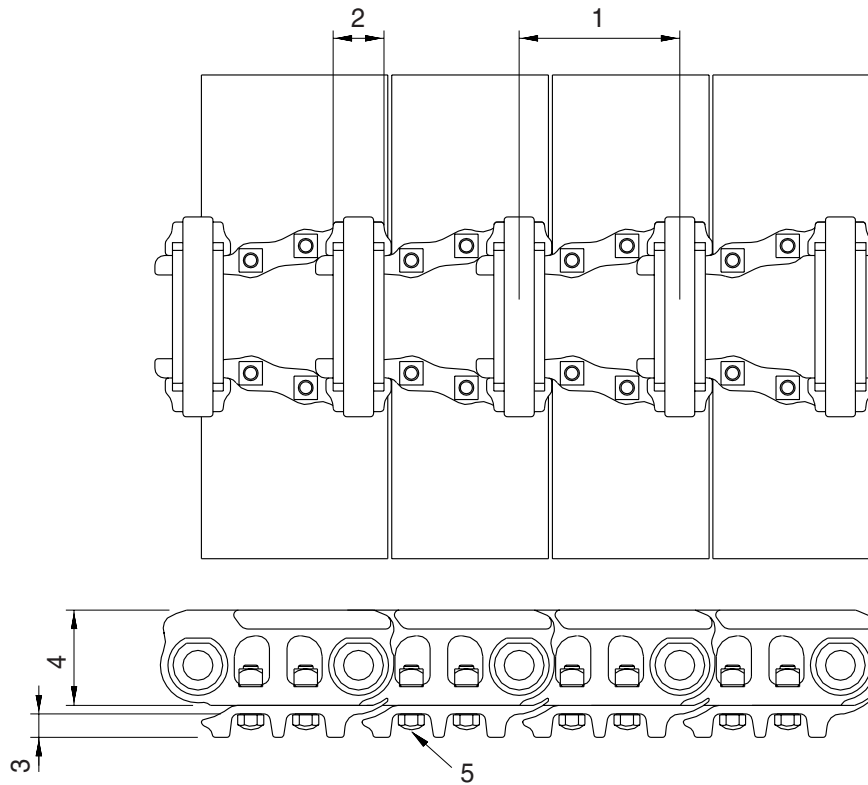

21037MS04

Unit : mm

No.	Check item	Criteria		Remedy
		Standard size	Repair limit	
1	Link pitch	215.9	220.9	Turn or replace
2	Outside diameter of bushing	∅ 71	∅ 60.4	
3	Height of grouser	36	21	Rebuild or replace
4	Height of link	129	115	
5	Tightening torque	Initial tightening torque : $140 \pm 14 \text{kgf} \cdot \text{m}$		Retighten

## 5) TRACK FRAME AND RECOIL SPRING

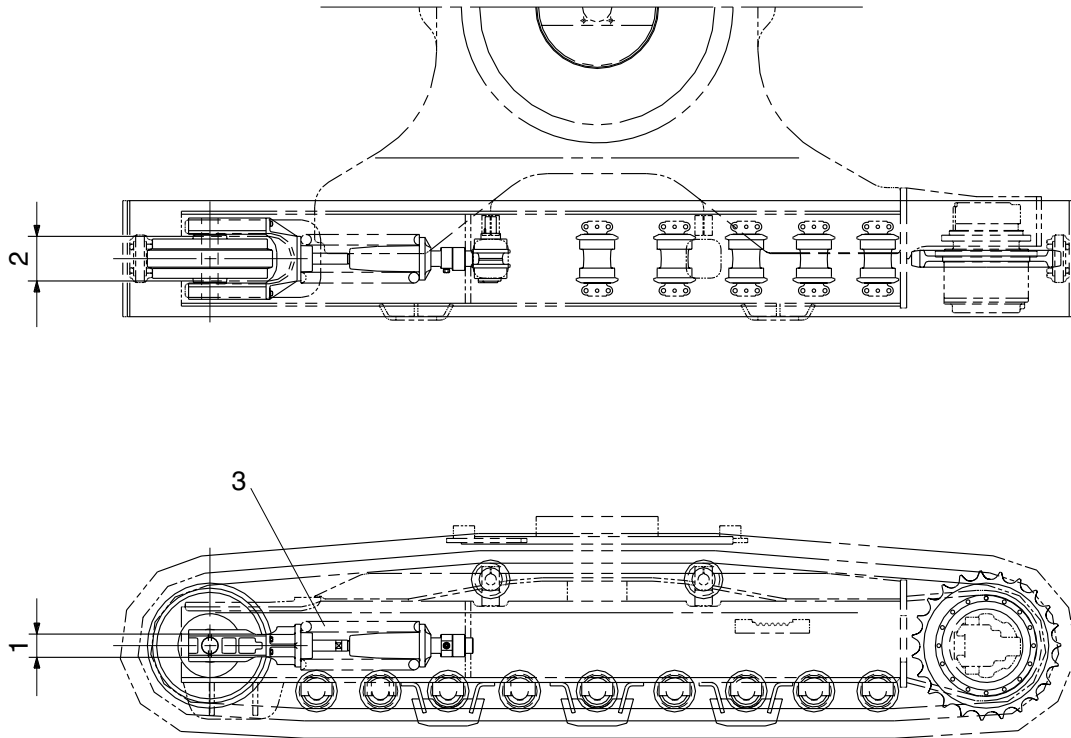

21037MS05

Unit : mm

No.	Check item	Criteria				Remedy	
			Standard size	Tolerance	Repair limit		
1	Vertical width of idler guide	Track frame	123	+2 -1	127	Rebuild or replace	
		Idler support	120	0 -1.5	116		
2	Horizontal width of idler guide	Track frame	292	+2 -1	296		
		Idler support	290	-	287		
3	Recoil spring	Standard size		Repair limit		Replace	
		Free length	Installation length	Installation load	Free length		Installation load
		∅ 251 × 826.5	670.2	21100kg	-		16880kg

## 2. WORK EQUIPMENT

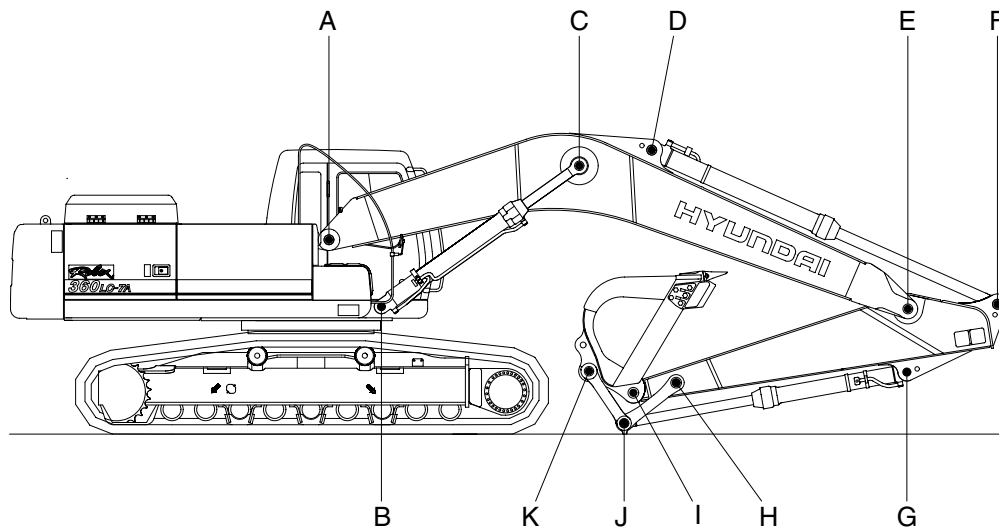

3607A7MS20

Unit : mm

Mark	Measuring point (Pin and Bushing)	Normal value	Pin		Bushing		Remedy & Remark
			Recomm. service limit	Limit of use	Recomm. service limit	Limit of use	
A	Boom Rear	120	119	118.5	120.5	121	Replacement
B	Boom Cylinder Head	100	99	98.5	100.5	101	"
C	Boom Cylinder Rod	110	109	108.5	110.5	111	"
D	Arm Cylinder Head	110	109	108.5	110.5	111	"
E	Boom Front	110	109	108.5	110.5	111	"
F	Arm Cylinder Rod	110	109	108.5	110.5	111	"
G	Bucket Cylinder Head	90	89	88.5	90.5	91	"
H	Arm Link	90	89	88.5	90.5	91	"
I	Bucket and Arm Link	100	99	98.5	100.5	101	"
J	Bucket Cylinder Rod	90	89	88.5	90.5	91	"
K	Bucket Link	100	99	98.5	100.5	101	"