

# GROUP 2 SPECIFICATIONS

## 1. MAJOR COMPONENT

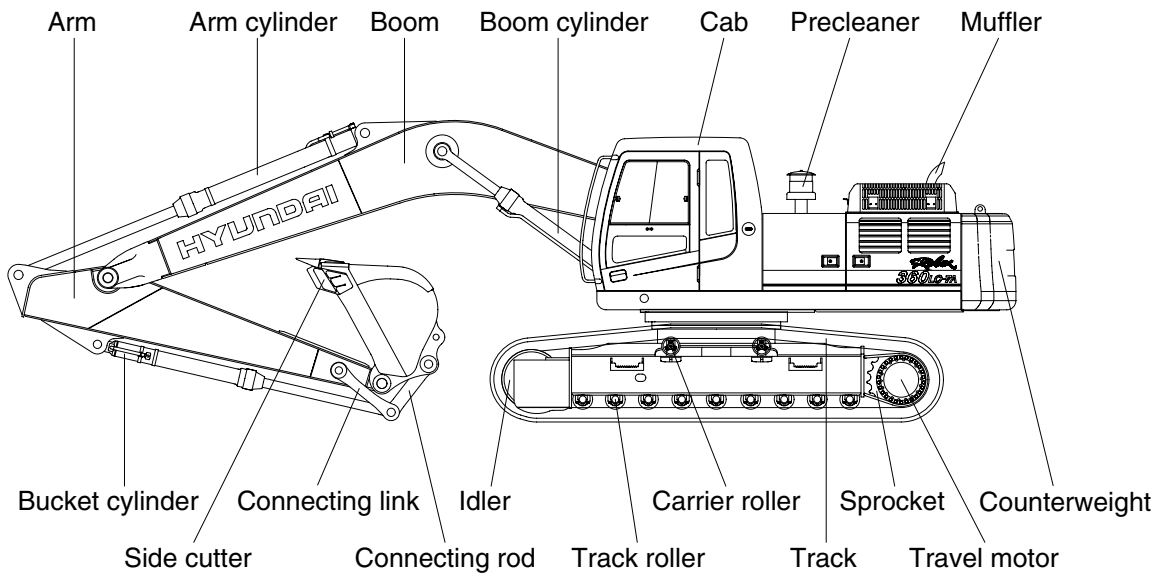
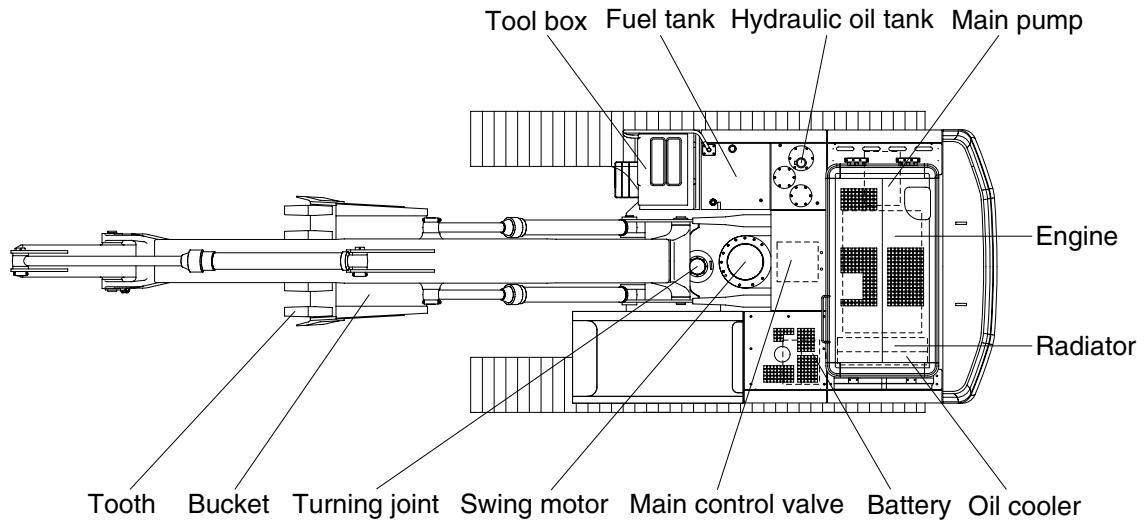

3607A2SP00

## 2. SPECIFICATIONS

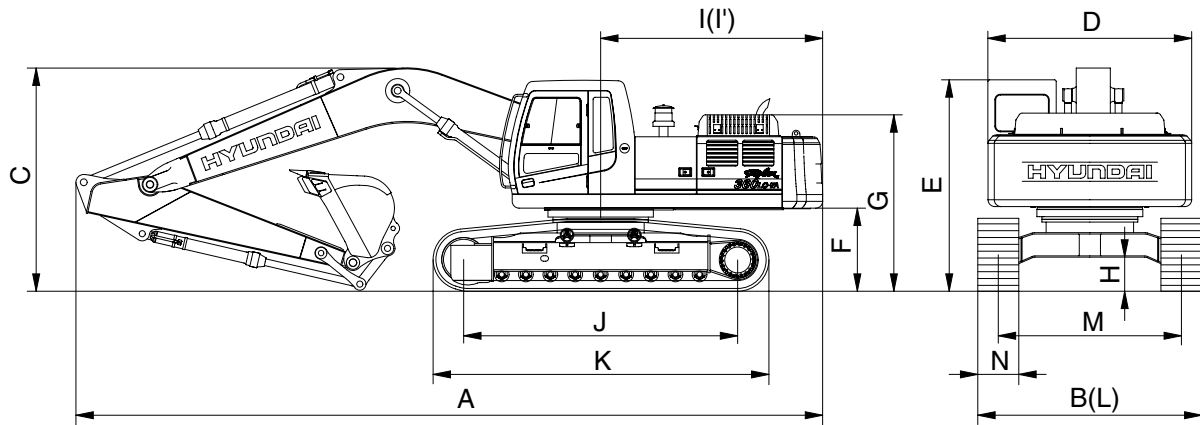

36072ASP01

Description		Unit	Specification
Operating weight		kg(lb)	36100(79590)
Bucket capacity(SAE heaped), standard		m <sup>3</sup> (yd <sup>3</sup> )	1.62(2.12)
Overall length	A	mm(ft-in)	11120(36' 6")
Overall width, with 600mm shoe	B		3340(10' 11")
Overall height	C		3440(11' 3")
Superstructure width	D		2980( 9' 9")
Overall height of cab	E		3175(10' 5")
Ground clearance of counterweight	F		1290( 4' 3")
Engine cover height	G		3190(10' 6")
Minimum ground clearance	H		550( 1' 10")
Rear-end distance	I		3350(11' 1")
Rear-end swing radius	I'		3415(11' 2")
Distance between tumblers	J		4340(14' 3")
Undercarriage length	K		5280(17' 4")
Undercarriage width	L		3340(11' 0")
Track gauge	M		2740( 9' 0")
Track shoe width, standard	N		600(24")
Travel speed(Low/high)		km/hr(mph)	3.2/4.5(2.0/2.8)
Swing speed		rpm	9.0
Gradeability		Degree(%)	35(70)
Ground pressure(600mm shoe)		kgf/cm <sup>2</sup> (psi)	0.64(9.10)

### 3. WORKING RANGE

#### 1) 6.5m(21' 4") BOOM

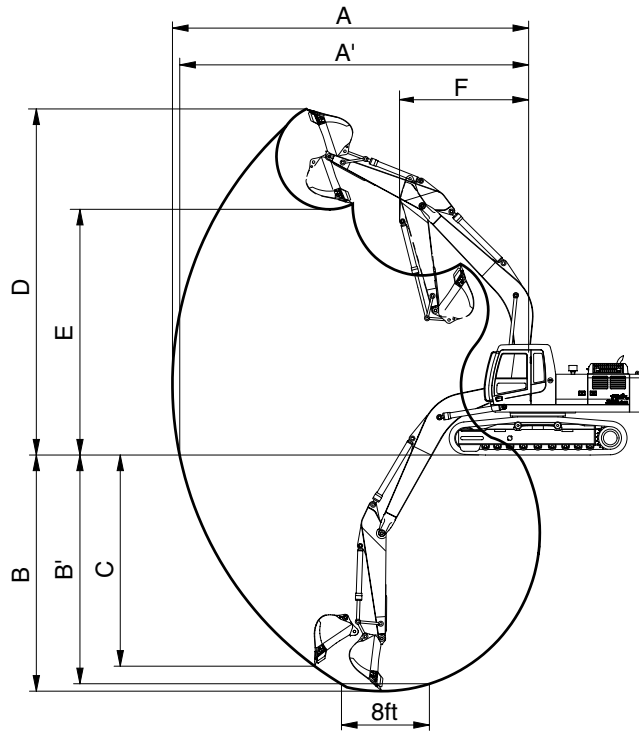

3607A2SP04

Description		2.5m(8' 2") Arm	*3.2m(10' 6") Arm	3.9m(12' 10") Arm	4.3m(14' 1") Arm
Max digging reach	A	10720mm(35' 2")	11250mm (36'11")	11870mm(38'11")	12380mm(40' 7")
Max digging reach on ground	A'	10490mm(34' 5")	11000mm (36' 1")	11670mm(38' 3")	12180mm(40' 0")
Max digging depth	B	6800mm(22' 4")	7500mm (24' 7")	8200mm(26'11")	8600mm(28' 3")
Max digging depth (8ft level)	B'	6620mm(21' 9")	7350mm (24' 1")	8070mm(26' 6")	8480mm(27'10")
Max vertical wall digging depth	C	5940mm(19' 6")	6340mm (20'10")	7040mm(23' 1")	7550mm(24' 9")
Max digging height	D	10470mm(34' 4")	10430mm (34' 3")	10650mm(34'11")	11210mm(36' 9")
Max dumping height	E	7270mm(23'10")	7290mm (23'11")	7510mm(24' 8")	8030mm(26' 4")
Min swing radius	F	4630mm(15' 2")	4560mm (15' 0")	4550mm(14'11")	4570mm(15' 0")
Bucket digging force	SAE	201.0[219.3]kN	201.0[219.3]kN	201.0[219.3]kN	201.0[219.3]kN
		20500[22360]kgf	20500[22360]kgf	20500[22360]kgf	20500[22360]kgf
		45190[49300]lbf	45190[49300]lbf	45190[49300]lbf	45190[49300]lbf
	ISO	228.5[249.3]kN	228.5[249.3]kN	228.5[249.3]kN	228.5[249.3]kN
		23300[25420]kgf	23300[25420]kgf	23300[25420]kgf	23300[25420]kgf
		51370[56040]lbf	51370[56040]lbf	51370[56040]lbf	51370[56040]lbf
Arm crowd force	SAE	184.4[201.1]kN	152.0[165.8]kN	135.3[147.6]kN	124.5[135.9]kN
		18800[20510]kgf	15500[16910]kgf	13800[15050]kgf	12700[13850]kgf
		41450[45220]lbf	34170[37280]lbf	30420[33190]lbf	28000[30550]lbf
	ISO	192.2[209.7]kN	156.9[171.2]kN	139.3[151.9]kN	128.5[140.1]kN
		19600[21380]kgf	16000[17450]kgf	14200[15490]kgf	13100[14290]kgf
		43210[47140]lbf	35270[38480]lbf	31310[34160]lbf	28880[31510]lbf

[ ] : Power boost

\* : STD

· 6.15m(20' 2") BOOM

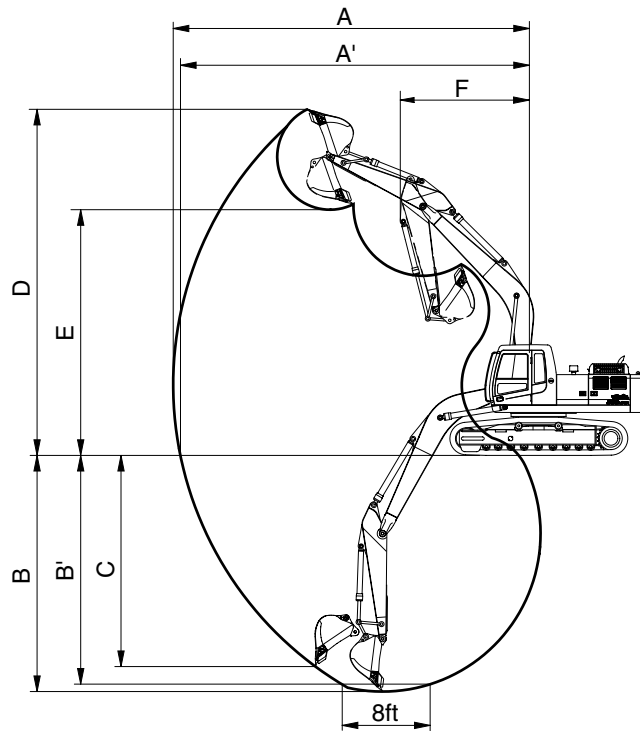

3607A2SP04

Description		2.5m(8' 2") Arm
Max digging reach	A	10330mm(33'11")
Max digging reach on ground	A'	10100mm(33' 2")
Max digging depth	B	6440mm(21' 2")
Max digging depth (8ft level)	B'	6260mm(20' 6")
Max vertical wall digging depth	C	5500mm(18' 1")
Max digging height	D	10200mm(33' 6")
Max dumping height	E	7020mm(23' 0")
Min swing radius	F	4320mm(14' 2")
Bucket digging force	SAE	201.0[219.3] kN
		20500[22360] kgf
		45190[49300] lbf
	ISO	228.5[249.3] kN
		23300[25420] kgf
		51370[56040] lbf
Arm crowd force	SAE	184.4[201.1] kN
		18800[20510] kgf
		41450[45220] lbf
	ISO	192.2[209.7] kN
		19600[21380] kgf
		43210[47140] lbf

[ ] : Power boost

• 8.6m(28' 3") BOOM

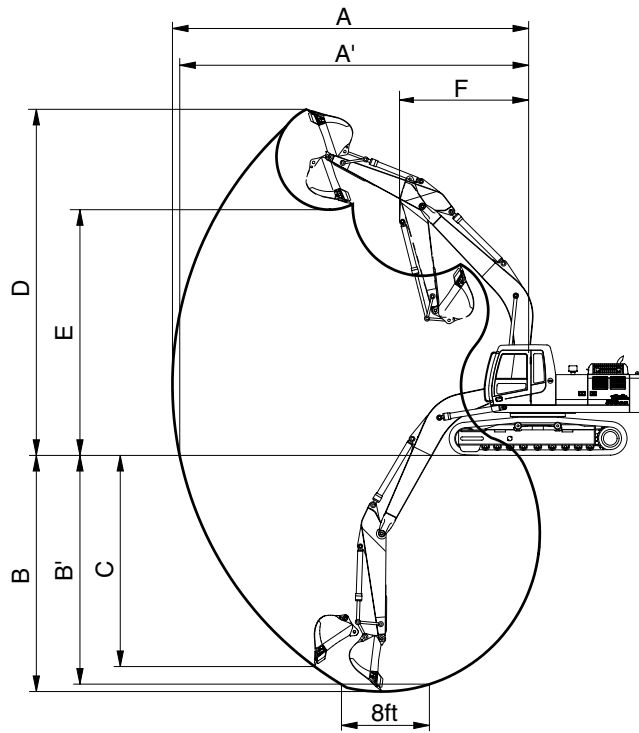

3607A2SP04

Description		5.1m(16' 9") Arm
Max digging reach	A	15300mm(50' 2")
Max digging reach on ground	A'	15120mm(49' 7")
Max digging depth	B	11210mm(36' 9")
Max digging depth (8ft level)	B'	11100mm(36' 5")
Max vertical wall digging depth	C	10070mm(33' 0")
Max digging height	D	13160mm(43' 2")
Max dumping height	E	9990mm(32' 9")
Min swing radius	F	6040mm(19'10")
Bucket digging force	SAE	202[220.4] kN
		20600[22470] kgf
		45420[49550] lbf
	ISO	229.5[250.3] kN
		23400[25530] kgf
		51590[56280] lbf
Arm crowd force	SAE	109.8[119.8] kN
		11200[12220] kgf
		24690[26930] lbf
	ISO	112.8[123.0] kN
		11500[12550] kgf
		25350[27650] lbf

[ ] : Power boost















#### 4. WEIGHT

Item	R360LC-7A	
	kg	lb
Upperstructure assembly	11620	25620
Main frame weld assembly	2810	6200
Engine assembly	740	1630
Main pump assembly	190	420
Main control valve assembly	250	550
Swing motor assembly	360	790
Hydraulic oil tank assembly	230	510
Fuel tank assembly	240	530
Counterweight	6500	14330
Cab assembly	310	680
Lower chassis assembly	5270	11620
Track frame weld assembly	14140	31170
Swing bearing	560	1230
Travel motor assembly	380	840
Turning joint	50	110
Track recoil spring and idler	420	930
Idler	180	400
Carrier roller	40	90
Track roller	80	180
Track-chain assembly(600mm standard triple grouser shoe)	2360	5200
Front attachment assembly(6.5m boom, 3.2m arm, 1.62m <sup>3</sup> SAE heaped bucket)	7660	16890
6.5m boom assembly	3020	6660
3.2m arm assembly	1280	2820
1.62m <sup>3</sup> SAE heaped bucket	1280	2820
Boom cylinder assembly	340	750
Arm cylinder assembly	460	1010
Bucket cylinder assembly	290	640
Bucket control linkage assembly	350	770

## 5. LIFTING CAPACITIES











1) 6.5m(21' 4") boom, 3.2m(10' 6") arm equipped with 1.62m<sup>3</sup>(SAE heaped) bucket and 600mm (24") triple grouser shoe with 6500kg(14,330lb) counterweight.

-  : Rating over-front
-  : Rating over-side or 360 degree















Load point height		Load radius												At max. reach			
		1.5m(5ft)		3.0m(10ft)		4.5m(15ft)		6.0m(20ft)		7.5m(25ft)		9.0m(30ft)		Capacity		Reach	
																m(ft)	
9.0m (30ft)	kg lb														*6020 *13270	*6020 *13270	7.97 (26.1)
7.5m (25ft)	kg lb									*4590 *10120	*4590 *10120			*6110 *13470	4650 10250	9.12 (29.9)	
6.0m (20ft)	kg lb									*6710 *14790	6590 14530			*6140 *13540	3860 8510	9.87 (32.4)	
4.5m (15ft)	kg lb							*8350 *18410	*8350 *18410	*7420 *16360	6290 13870	*4490 *9900	4440 9790	6020 13270	3410 7520	10.32 (33.9)	
3.0m (10ft)	kg lb					*13690 *30180	13640 30070	*10100 *22270	8600 18960	*8370 *18450	5930 13070	*6400 *14110	4260 9390	5710 12590	3180 7010	10.50 (34.4)	
1.5m (5ft)	kg lb					*16650 *36710	12420 27380	*11760 *25930	7980 17590	*9330 *20570	5590 12320	7260 16010	4080 8990	5670 12500	3120 6880	10.45 (34.3)	
Ground Line	kg lb			*13060 *28790	*13060 *28790	*18210 *40150	11800 26010	*12930 *28510	7540 16620	9560 21080	5320 11730	7100 15650	3930 8660	5900 13010	3240 7140	10.14 (33.3)	
-1.5m (-5ft)	kg lb	*13680 *30160	*13680 *30160	*17490 *38560	*17490 *38560	*18550 *40900	11600 25570	*13460 *29670	7330 16160	9400 20720	5170 11400			6480 14290	3590 7910	9.57 (31.4)	
-3.0m (-10ft)	kg lb	*17850 *39350	*17850 *39350	*22770 *50200	*22770 *50200	*17870 *39400	11660 25710	*13210 *29120	7310 16120	9400 20720	5180 11420			7700 16980	4320 9520	8.65 (28.4)	
-4.5m (-15ft)	kg lb	*22570 *49760	*22570 *49760	*22590 *49800	*22590 *49800	*16000 *35270	11960 26370	*11870 *26170	7510 16560					*8000 *17640	5980 13180	7.25 (23.8)	
-6.0m (-20ft)	kg lb					*11900 *26230	*11900 *26230										

- Note
1. Lifting capacity are based on SAE J1097 and ISO 10567.
  2. Lifting capacity of the ROBEX series does not exceed 75% of tipping load with the machine on firm, level ground or 87% of full hydraulic capacity.
  3. The load point is a hook located on the back of the bucket.
  4. \*indicates load limited by hydraulic capacity.

2) 6.5m(21' 4") boom, 2.50m(8' 2") arm equipped with 1.62m<sup>3</sup>(SAE heaped) bucket and 600mm (24") triple grouser shoe with 6500kg(14,330lb) counterweight.



















Load point height		Load radius								At max. reach				
		3.0m(10ft)		4.5m(15ft)		6.0m(20ft)		7.5m(25ft)		Capacity		Reach		
												m(ft)		
9.0m (30ft)	kg lb											*6900 *15210	*6900 *15210	7.22 (23.7)
7.5m (25ft)	kg lb											*6870 *15150	5190 11440	8.49 (27.9)
6.0m (20ft)	kg lb					*8050 *17750	*8050 *17750	*7580 *16710	6370 14040	*6970 *15370	4240 9350	9.29 (30.5)		
4.5m (15ft)	kg lb			*11980 *26410	*11980 *26410	*9400 *20720	8990 19820	*8180 *18030	6110 13470	6550 14440	3720 8200	9.77 (32.1)		
3.0m (10ft)	kg lb			*15410 *33970	12960 28570	*11030 *24320	8330 18360	*9020 *19890	5790 12760	6210 13690	3470 7650	9.97 (32.7)		
1.5m (5ft)	kg lb			*17780 *39200	12000 26460	*12460 *27470	7780 17150	9750 21500	5490 12100	6180 13620	3430 7560	9.91 (32.5)		
Ground Line	kg lb			*18570 *40940	11650 25680	*13320 *29370	7450 16420	9520 20990	5280 11640	6490 14310	3610 7960	9.59 (31.5)		
-1.5m (-5ft)	kg lb	*17800 *39240	*17800 *39240	*18280 *40300	11630 25640	*13480 *29720	7340 16180	9440 20810	5210 11490	7260 16010	4070 8970	8.97 (29.4)		
-3.0m (-10ft)	kg lb	*23550 *51920	*23550 *51920	*17040 *37570	11830 26080	*12770 *28150	7430 16380			*8130 *17920	5070 11180	7.97 (26.1)		
-4.5m (-15ft)	kg lb	*19520 *43030	*19520 *43030	*14370 *31680	12280 27070					*7460 *16450	7460 16450	6.39 (21.0)		

3) 6.5m(21' 4") boom, 3.9m(12' 10") arm equipped with 1.62m<sup>3</sup>(SAE heaped) bucket and 600mm (24") triple grouser shoe with 6500kg(14,330lb) counterweight.













Load point height		Load radius										At max. reach				
		1.5m(5ft)		3.0m(10ft)		4.5m(15ft)		6.0m(20ft)		7.5m(25ft)		9.0m(30ft)		Capacity		Reach
																m(ft)
9.0m (30ft)	kg lb													*5290 *11660	5130 11310	8.81 (28.9)
7.5m (25ft)	kg lb													*5420 *11950	4000 8820	9.85 (32.3)
6.0m (20ft)	kg lb								*5890 *12990	*5890 *12990	*3660 *8070	*3660 *8070	*5590 *12320	3360 7410	10.54 (34.6)	
4.5m (15ft)	kg lb								*6660 *14680	6330 13960	*5450 *12020	4440 9790	5380 11860	2980 6570	10.95 (35.9)	
3.0m (10ft)	kg lb			*19900 *43870	*19900 *43870	*12040 *26540	*12040 *26540	*9120 *20110	8690 19160	*7660 *16890	5930 13070	*6860 *15120	4230 9330	5120 11290	2780 6130	11.13 (36.5)
1.5m (5ft)	kg lb			*12660 *27910	*12660 *27910	*15330 *33800	12590 27760	*10910 *24050	7990 17610	*8710 *19200	5540 12210	7200 15870	4000 8820	5060 11160	2720 6000	11.07 (36.3)
Ground Line	kg lb			*13680 *30160	*13680 *30160	*17420 *38400	11750 25900	*12310 *27140	7470 16470	9470 20880	5220 11510	6990 15410	3820 8420	5230 11530	2800 6170	10.79 (35.4)
-1.5m (-5ft)	kg lb	*12590 *27760	*12590 *27760	*16830 *37100	*16830 *37100	*18250 *40230	11390 25110	*13100 *28880	7170 15810	9240 20370	5020 11070	6870 15150	3710 8180	5670 12500	3060 6750	10.26 (33.7)
-3.0m (-10ft)	kg lb	*16200 *35710	*16200 *35710	*21040 *46390	*21040 *46390	*18030 *39750	11340 25000	*13170 *29030	7080 15610	9170 20220	4960 10930		6560 14460	3600 7940	9.42 (30.9)	
-4.5m (-15ft)	kg lb	*20270 *44690	*20270 *44690	*24240 *53440	*24240 *53440	*16700 *36820	11540 25440	*12330 *27180	7180 15830	*9270 *20440	5080 11200		*7640 *16840	4710 10380	8.17 (26.8)	
-6.0m (-20ft)	kg lb			*19460 *42900	*19460 *42900	*13690 *30180	12040 26540									













4) 6.5m(21' 4") boom, 4.3m(14' 1") arm equipped with 1.62m<sup>3</sup>(SAE heaped) bucket and 600mm (24") triple grouser shoe with 6500kg(14,330lb) counterweight.

Load point height		Load radius														At max. reach			
		1.5m(5ft)		3.0m(10ft)		4.5m(15ft)		6.0m(20ft)		7.5m(25ft)		9.0m(30ft)		10.5m(35ft)		Capacity		Reach	
																			
9.0m (30ft)	kg lb																*5050 *11130	4420 9740	9.45 (31.0)
7.5m (25ft)	kg lb														*2740 *6040	*2740 *6040	*4810 *10600	3510 7740	10.42 (34.2)
6.0m (20ft)	kg lb														*4460 *9830	*4460 *9830	*4700 *10360	2980 6570	11.07 (36.3)
4.5m (15ft)	kg lb									*6110 *13470	*6110 *13470	*5620 *12390	4490 9900				*4730 *10430	2650 5840	11.46 (37.6)
3.0m (10ft)	kg lb			*17000 *37480	*17000 *37480	*10840 *23900	*10840 *23900	*8410 *18540	*8410 *18540	*7160 *15790	6000 13230	*6460 *14240	4250 9370	*2660 *5860	*2660 *5860	4680 10320	2480 5470	11.63 (38.2)	
1.5m (5ft)	kg lb			*13680 *30160	*13680 *30160	*14340 *31610	12850 28330	*10300 *22710	8090 17840	*8270 *18230	5580 12300	*7120 *15700	4000 8820	*2990 *6590	2920 6440	4630 10210	2430 5360	11.58 (38.0)	
Ground Line	kg lb			*13030 *28730	*13030 *28730	*16790 *37020	11840 26100	*11850 *26120	7500 16530	*9250 *20390	5220 11510	6970 15370	3790 8360			4770 10520	2500 5510	11.31 (37.1)	
-1.5m (-5ft)	kg lb	*11080 *24430	*11080 *24430	*15420 *34000	*15420 *34000	*17980 *39640	11350 25020	*12820 *28260	7140 15740	9210 20300	4980 10980	6810 15010	3650 8050			5140 11330	2710 5970	10.81 (35.5)	
-3.0m (-10ft)	kg lb	*14380 *31700	*14380 *31700	*19060 *42020	*19060 *42020	*18090 *39880	11210 24710	*13120 *28920	6990 15410	9090 20040	4870 10740	*6650 *14660	3610 7960			5870 12940	3160 6970	10.02 (32.9)	
-4.5m (-15ft)	kg lb	*18170 *40060	*18170 *40060	*24050 *53020	*24050 *53020	*17140 *37790	11340 25000	*12590 *27760	7040 15520	9150 20170	4930 10870					*6970 *15370	4020 8860	8.87 (29.1)	
-6.0m (-20ft)	kg lb	*22830 *50330	*22830 *50330	*21250 *46850	*21250 *46850	*14730 *32470	11750 25900	*10720 *23630	7330 16160							*6830 *15060	6040 13320	7.15 (23.5)	











5) 6.15m(20' 2") boom, 2.5m(8' 2") arm equipped with 1.62m<sup>3</sup>(SAE heaped) bucket and 600mm (24") triple grouser shoe with 6500kg(14,330lb) counterweight.

Load point height		Load radius								At max. reach					
		3.0m(10ft)		4.5m(15ft)		6.0m(20ft)		7.5m(25ft)		Capacity		Reach			
														m(ft)	
9.0m (30ft)	kg lb												*7640 *16840	*7640 *16840	6.65 (21.8)
7.5m (25ft)	kg lb												*7520 *16580	5970 13160	8.02 (26.3)
6.0m (20ft)	kg lb							*8660 *19090	*8660 *19090	*6540 *14420	6530 14400	*7580 *16710	4800 10580	8.88 (29.1)	
4.5m (15ft)	kg lb	*18380 *40520	*18380 *40520	*12260 *27030	*12260 *27030	*9890 *21800	9350 20610	*8740 *19270	6330 13960	7200 15870	4190 9240	9.38 (30.8)			
3.0m (10ft)	kg lb			*15570 *34330	13710 30230	*11460 *25260	8720 19220	*9500 *20940	6030 13290	6790 14970	3890 8580	9.58 (31.4)			
1.5m (5ft)	kg lb			*18030 *39750	12630 27840	*12850 *28330	8150 17970	10010 22070	5730 12630	6750 14880	3830 8440	9.52 (31.2)			
Ground Line	kg lb	*13370 *29480	*13370 *29480	*18930 *41730	12120 26720	*13670 *30140	7770 17130	9760 21520	5500 12130	7090 15630	4010 8840	9.19 (30.2)			
-1.5m (-5ft)	kg lb	*20990 *46270	*20990 *46270	*18580 *40960	11990 26430	*13710 *30230	7610 16780	9650 21270	5410 11930	7990 17610	4540 10010	8.53 (28.0)			
-3.0m (-10ft)	kg lb	*23670 *52180	*23670 *52180	*17040 *37570	12100 26680	*12670 *27930	7650 16870			*8470 *18670	5730 12630	7.47 (24.5)			
-4.5m (-15ft)	kg lb	*18590 *40980	*18590 *40980	*13590 *29960	12520 27600										















6) 6.15m(20' 2") boom, 2.5m(8' 2") arm equipped with 1.62m<sup>3</sup>(SAE heaped) bucket and 800mm (32") triple grouser shoe with 6500kg(14,330lb) counterweight.

Load point height		Load radius								At max. reach		
		3.0m(10ft)		4.5m(15ft)		6.0m(20ft)		7.5m(25ft)		Capacity		Reach
												m(ft)
9.0m (30ft)	kg lb									*7640 *16840	*7640 *16840	6.65 (21.8)
7.5m (25ft)	kg lb									*7520 *16580	6120 13490	8.02 (26.3)
6.0m (20ft)	kg lb					*8660 *19090	*8660 *19090	*6540 *14420	*6540 *14420	*7580 *16710	4940 10890	8.88 (29.1)
4.5m (15ft)	kg lb	*18380 *40520	*18380 *40520	*12260 *27030	*12260 *27030	*9890 *21800	9560 21080	*8740 *19270	6490 14310	7410 16340	4310 9500	9.38 (30.8)
3.0m (10ft)	kg lb			*15570 *34330	14040 30950	*11460 *25260	8930 19690	*9500 *20940	6190 13650	6990 15410	4010 8840	9.58 (31.4)
1.5m (5ft)	kg lb			*18030 *39750	12960 28570	*12850 *28330	8370 18450	*10240 *22580	5890 12990	6950 15320	3950 8710	9.52 (31.2)
Ground Line	kg lb	*13370 *29480	*13370 *29480	*18930 *41730	12450 27450	*13670 *30140	7990 17610	10030 22110	5670 12500	7300 16090	4140 9130	9.19 (30.2)
-1.5m (-5ft)	kg lb	*20990 *46270	*20990 *46270	*18580 *40960	12310 27140	*13710 *30230	7820 17240	9920 21870	5570 12280	8220 18120	4680 10320	8.53 (28.0)
-3.0m (-10ft)	kg lb	*23670 *52180	*23670 *52180	*17040 *37570	12430 27400	*12670 *27930	7870 17350			*8470 *18670	5900 13010	7.47 (24.5)
-4.5m (-15ft)	kg lb	*18590 *40980	*18590 *40980	*13590 *29960	12850 28330							















7) 6.5m(21' 4") boom, 2.5m(8' 2") arm equipped with 1.62m<sup>3</sup>(SAE heaped) bucket and 800mm (32") triple grouser shoe with 6500kg(14,330lb) counterweight.

Load point height		Load radius								At max. reach		
		3.0m(10ft)		4.5m(15ft)		6.0m(20ft)		7.5m(25ft)		Capacity		Reach
												m(ft)
9.0m (30ft)	kg lb									*6900 *15210	*6900 *15210	7.22 (23.7)
7.5m (25ft)	kg lb									*6870 *15150	5330 11750	8.49 (27.9)
6.0m (20ft)	kg lb					*8050 *17750	*8050 *17750	*7580 *16710	6530 14400	*6970 *15370	4360 9610	9.29 (30.5)
4.5m (15ft)	kg lb			*11980 *26410	*11980 *26410	*9400 *20720	9200 20280	*8180 *18030	6280 13850	6740 14860	3840 8470	9.77 (32.1)
3.0m (10ft)	kg lb			*15410 *33970	13290 29300	*11030 *24320	8540 18830	*9020 *19890	5950 13120	6390 14860	3590 7910	9.97 (32.7)
1.5m (5ft)	kg lb			*17780 *39200	12320 27160	*12460 *27470	8000 17640	*9830 *21670	5650 12460	6370 14040	3550 7830	9.91 (32.5)
Ground Line	kg lb			*18570 *40940	11980 26410	*13320 *29370	7670 16910	9790 21580	5450 12020	6690 14750	3730 8220	9.59 (31.5)
-1.5m (-5ft)	kg lb	*17800 *39240	*17800 *39240	*18280 *40300	11960 26370	*13480 *29720	7560 16670	9710 21410	5370 11840	7480 16490	4200 9260	8.97 (29.4)
-3.0m (-10ft)	kg lb	*23550 *51920	*23550 *51920	*17040 *37570	12150 26790	*12770 *28150	7640 16840			*8130 *17920	5220 11510	7.97 (26.1)
-4.5m (-15ft)	kg lb	*19520 *43030	*19520 *43030	*14370 *31680	12600 27780					*7460 *16450	*7460 *16450	6.39 (21.0)

8) 6.5m(21' 4") boom, 3.2m(10' 6") arm equipped with 1.62m<sup>3</sup>(SAE heaped) bucket and 800mm (32") triple grouser shoe with 6500kg(14,330lb) counterweight.

Load point height		Load radius												At max. reach			
		1.5m(5ft)		3.0m(10ft)		4.5m(15ft)		6.0m(20ft)		7.5m(25ft)		9.0m(30ft)		Capacity		Reach	
																	m(ft)
9.0m (30ft)	kg lb														*6020 *13270	*6020 *13270	7.97 (26.1)
7.5m (25ft)	kg lb								*4590 *10120	*4590 *10120					*6110 *13470	4780 10540	9.12 (29.9)
6.0m (20ft)	kg lb								*6710 *14790	*6710 *14790					*6140 *13540	3970 8750	9.87 (32.4)
4.5m (15ft)	kg lb							*8350 *18410	*8350 *18410	*7420 *16360	6460 14240	*4490 *9900	*4490 *9900	6200 13670	3520 7760	10.32 (33.9)	
3.0m (10ft)	kg lb					*13690 *30180	*13690 *30180	*10100 *22270	8820 19440	*8370 *18450	6100 13450	*6400 *14110	4390 9680	5890 12990	3290 7250	10.50 (34.4)	
1.5m (5ft)	kg lb					*16650 *36710	12750 28110	*11760 *25930	8190 18060	*9330 *20570	5750 12680	7470 16470	4210 9280	5850 12900	3240 7140	10.45 (34.3)	
Ground Line	kg lb			*13060 *28790	*13060 *28790	*18210 *40150	12130 26740	*12930 *28510	7760 17110	9840 21690	5480 12080	*7120 *15700	4060 8950	6080 13400	3360 7410	10.14 (33.3)	
-1.5m (-5ft)	kg lb	*13680 *30160	*13680 *30160	*17490 *38560	*17490 *38560	*18550 *40900	11930 26300	*13460 *29670	7550 16640	9670 21320	5340 11770			6680 14730	3710 8180	9.57 (31.4)	
-3.0m (-10ft)	kg lb	*17850 *39350	*17850 *39350	*22770 *50200	*22770 *50200	*17870 *39400	11990 26430	*13210 *29120	7530 16600	9670 21320	5340 11770			7930 17480	4460 9830	8.65 (28.4)	
-4.5m (-15ft)	kg lb	*22570 *49760	*22570 *49760	*22590 *49800	*22590 *49800	*16000 *35270	12290 27090	*11870 *26170	7730 17040					*8000 *17640	6150 13560	7.25 (23.8)	
-6.0m (-20ft)	kg lb					*11900 *26230	*11900 *26230										

9) 6.5m(21' 4") boom, 3.9m(12' 10") arm equipped with 1.62m<sup>3</sup>(SAE heaped) bucket and 800mm (32") triple grouser shoe with 6500kg(14,330lb) counterweight.

Load point height		Load radius												At max. reach				
		1.5m(5ft)		3.0m(10ft)		4.5m(15ft)		6.0m(20ft)		7.5m(25ft)		9.0m(30ft)		Capacity		Reach		
																	m(ft)	
9.0m (30ft)	kg lb															*5290 *11660	5260 11600	8.81 (28.9)
7.5m (25ft)	kg lb															*5420 *11950	4120 9080	9.85 (32.3)
6.0m (20ft)	kg lb									*5890 *12990	*5890 *12990	*3660 *8070	*3660 *8070	*5590 *12320	3470 7650	10.54 (34.6)		
4.5m (15ft)	kg lb									*6660 *14680	6500 14330	*5450 *12020	4580 10100	5550 12240	3090 6810	10.95 (35.9)		
3.0m (10ft)	kg lb			*19900 *43870	*19900 *43870	*12040 *26540	*12040 *26540	*9120 *20110	8910 19640	*7660 *16890	6100 13450	*6860 *15120	4360 9610	5280 11640	2880 6350	11.13 (36.5)		
1.5m (5ft)	kg lb			*12660 *27910	*12660 *27910	*15330 *33800	12920 28480	*10910 *24050	8210 18100	*8710 *19200	5700 12570	7410 16340	4140 9130	5230 11530	2820 6220	11.07 (36.3)		
Ground Line	kg lb			*13680 *30160	*13680 *30160	*17420 *38400	12070 26610	*12310 *27140	7680 16930	*9600 *21160	5380 11860	7200 15870	3950 8710	5400 11900	2910 6420	10.79 (35.4)		
-1.5m (-5ft)	kg lb	*12590 *27760	*12590 *27760	*16830 *37100	*16830 *37100	*18250 *40230	11710 25820	*13100 *28880	7390 16290	9520 20990	5180 11420	7080 15610	3840 8470	5850 12900	3170 6990	10.26 (33.7)		
-3.0m (-10ft)	kg lb	*16200 *35710	*16200 *35710	*21040 *46390	*21040 *46390	*18030 *39750	11670 25730	*13170 *29030	7290 16070	9450 20830	5120 11290			6770 14930	3720 8200	9.42 (30.9)		
-4.5m (-15ft)	kg lb	*20270 *44690	*20270 *44690	*24240 *53440	*24240 *53440	*16700 *36820	11870 26170	*12330 *27180	7400 16310	*9270 *20440	5250 11570			*7640 *16840	4860 10710	8.17 (26.8)		
-6.0m (-20ft)	kg lb			*19460 *42900	*19460 *42900	*13690 *30180	12360 27250											

10) 6.5m(21' 4") boom, 4.3m(14' 1") arm equipped with 1.62m<sup>3</sup>(SAE heaped) bucket and 800mm (32") triple grouser shoe with 6500kg(14,330lb) counterweight.

Load point height		Load radius														At max. reach			
		1.5m(5ft)		3.0m(10ft)		4.5m(15ft)		6.0m(20ft)		7.5m(25ft)		9.0m(30ft)		10.5m(35ft)		Capacity		Reach	
																		m(ft)	
9.0m (30ft)	kg lb																*5050 *11130	4540 10010	9.45 (31.0)
7.5m (25ft)	kg lb											*2740 *6040	*2740 *6040				*4810 *10600	3620 7980	10.42 (34.2)
6.0m (20ft)	kg lb											*4460 *9830	*4460 *9830				*4700 *10360	3080 6790	11.07 (36.3)
4.5m (15ft)	kg lb								*6110 *13470	*6110 *13470	*5620 *12390	4620 10190				*4730 *10430	2750 6060	11.46 (37.6)	
3.0m (10ft)	kg lb			*17000 *37480	*17000 *37480	*10840 *23900	*10840 *23900	*8410 *18540	*8410 *18540	*7160 *15790	6170 13600	*6460 *14240	4380 9660	*2660 *5860	*2660 *5860	4830 10650	2580 5690	11.63 (38.2)	
1.5m (5ft)	kg lb			*13680 *30160	*13680 *30160	*14340 *31610	13180 29060	*10300 *22710	8310 18320	*8270 *18230	5740 12650	*7120 *15700	4140 9130	*2990 *6590	*2990 *6590	4790 10560	2520 5560	11.58 (38.0)	
Ground Line	kg lb			*13030 *28730	*13030 *28730	*16790 *37020	12170 26830	*11850 *26120	7720 17020	*9250 *20390	5380 11860	7180 15830	3920 8640			4930 10870	2600 5730	11.31 (37.1)	
-1.5m (-5ft)	kg lb	*11080 *24430	*11080 *24430	*15420 *34000	*15420 *34000	*17980 *39640	11680 25750	*12820 *28260	7360 16230	9480 20900	5140 11330	7030 15500	3780 8330			5310 11710	2820 6220	10.81 (35.5)	
-3.0m (-10ft)	kg lb	*14380 *31700	*14380 *31700	*19060 *42020	*19060 *42020	*18090 *39880	11540 25440	*13120 *28920	7210 15900	9360 20640	5040 11110	*6650 *14660	3750 8270			6050 13340	3270 7210	10.02 (32.9)	
-4.5m (-15ft)	kg lb	*18170 *40060	*18170 *40060	*24050 *53020	*24050 *53020	*17140 *37790	11670 25730	*12590 *27760	7250 15980	9430 20790	5090 11220					*6970 *15370	4160 9170	8.87 (29.1)	
-6.0m (-20ft)	kg lb	*22830 *50330	*22830 *50330	*21250 *46850	*21250 *46850	*14730 *32470	12070 26610	*10720 *23630	7550 16640							*6830 *15060	6220 13710	7.15 (23.5)	

11) 8.6m(21' 4") boom, 5.1m(14' 1") arm equipped with 1.62m<sup>3</sup>(SAE heaped) bucket and 600mm (24") triple grouser shoe with 10,700kg(23,590lb) counterweight.

Load point height		Load radius														At max. reach								
		1.5m(5ft)		3.0m(10.0ft)		4.5m(15.0ft)		6.0m(20.0ft)		7.5m(25.0ft)		9.0m(30.0ft)		10.5m(35.0ft)		12.0m(40.0ft)		13.5m(45.0ft)		Capacity		Reach		
																						m(ft)		
9.0m (30ft)	kg lb													*3080 *6790	*3080 *6790						*3130 *6900	*3130 *6900	12.91 (42.4)	
7.5m (25ft)	kg lb													*3180 *7010	*3180 *7010	*2670 *5890	*2670 *5890				*3200 *7050	2740 6040	13.61 (44.7)	
6.0m (20ft)	kg lb													*3450 *7610	*3450 *7610	*3400 *7500	*3400 *7500				*3290 *7250	2440 5380	14.10 (46.3)	
4.5m (15ft)	kg lb									*4190 *9240	*4190 *9240	*3830 *8440	*3830 *8440	*3630 *8000	3420 7540							*3410 *7520	2250 4960	14.40 (47.2)
3.0m (10ft)	kg lb			*11100 *24470	*11100 *24470	*7540 *16620	*7540 *16620	*5830 *12850	*5830 *12850	*4870 *10740	*4870 *10740	*4280 *9440	4260 9390	*3910 *8620	3260 7190	*1760 *3880	*1760 *3880	*3540 *7800	2130 4700	14.53 (47.7)				
1.5m (5ft)	kg lb			*10860 *23940	*10860 *23940	*9180 *20240	*9180 *20240	*6870 *15150	*6870 *15150	*5560 *12260	5250 11570	*4750 *10470	4010 8840	*4230 *9330	3090 6810	*1940 *4280	*1940 *4280	*3690 *8140	2090 4610	14.49 (47.5)				
Ground Line	kg lb			*10370 *22860	*10370 *22860	*10430 *22900	9120 20110	*7750 *17090	6560 14460	*6180 *13620	4930 10870	*5180 *11420	3800 8380	*4520 *9960	2960 6530			*3860 *8510	2120 4670	14.28 (46.9)				
-1.5m (-5ft)	kg lb			*7950 *17530	*7950 *17530	*11690 *25770	*11690 *25770	*11210 *24710	8750 19290	*8400 *18520	*6670 *14700	*4700 *10360	*5540 *12210	3630 8000	*4760 *10490	2860 6310					*4040 *8910	2230 4920	13.90 (45.6)	
-3.0m (-10ft)	kg lb	*8870 *19550	*8870 *19550	*10240 *22580	*10240 *22580	*13850 *30530	13680 30160	*11570 *25510	8600 18960	*8790 *19380	6090 13430	*6990 *15410	4570 10080	*5770 *12720	3540 7800	*4870 *10740	2810 6190				*4230 *9330	2440 5380	13.31 (43.7)	
-4.5m (-15ft)	kg lb	*11060 *24380	*11060 *24380	*12770 *28150	*12770 *28150	*15780 *34790	13820 30470	*11540 *25440	8610 18980	*8880 *19580	6050 13340	*7090 *15630	4530 9990	*5800 *12790	3530 7780			*4430 *9770	2790 6150	12.50 (37.4)				
-6.0m (-20ft)	kg lb	*13500 *29760	*13500 *29760	*15760 *34740	*15760 *34740	*14940 *32940	14100 31090	*11120 *24520	8750 19290	*8630 *19030	6130 13510	*6880 *15170	4600 10140	*5490 *12100	3630 8000			*4600 *10140	3390 7470	11.41 (37.4)				
-7.5m (-25ft)	kg lb	*16400 *36160	*16400 *36160	*19240 *42420	*19240 *42420	*13480 *29720	*13480 *29720	*10160 *22400	9040 19930	*7890 *17390	6350 1400	*6120 *13490	4820 10630					*4700 *10360	4480 9880	9.94 (32.6)				
-9.0m (-30ft)	kg lb			*15380 *33910	*15380 *33910	*11020 *24290	*11020 *24290	*8300 *18300	*8300 *18300	*6130 *13510	*6130 *13510													

## 6. BUCKET SELECTION GUIDE

### 1) GENERAL BUCKET

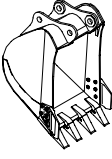
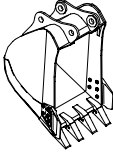
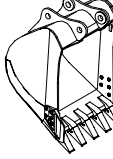
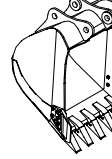
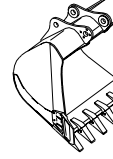
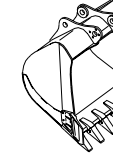
					
1.15m <sup>3</sup> SAE heaped bucket	1.46m <sup>3</sup> SAE heaped bucket	※ 1.62m <sup>3</sup> SAE heaped bucket	1.86m <sup>3</sup> SAE heaped bucket	2.10m <sup>3</sup> SAE heaped bucket	2.32m <sup>3</sup> SAE heaped bucket

Capacity		Width		Weight	6.5m (21' 4") boom				6.15m(20' 2") boom	8.6m(28' 3") boom
SAE heaped	CECE heaped	Without side cutter	With side cutter		2.5m arm (8' 2")	3.2m arm (10' 6")	3.9m arm (12' 10")	4.3m arm (14' 1")	2.5m arm (8' 2")	5.1m arm (16' 9")
1.15m <sup>3</sup> (1.5yd <sup>3</sup> )	1.0m <sup>3</sup> (1.3yd <sup>3</sup> )	1090mm (42.9")	1220mm (48.0")	1030kg (2270lb)						
1.46m <sup>3</sup> (1.91yd <sup>3</sup> )	1.27m <sup>3</sup> (1.66yd <sup>3</sup> )	1380mm (54.3")	1510mm (59.4")	1170kg (2580lb)						
※ 1.62m <sup>3</sup> (2.12yd <sup>3</sup> )	1.40m <sup>3</sup> (1.8yd <sup>3</sup> )	1440mm (56.7")	1570mm (61.8")	1280kg (2820lb)						
1.86m <sup>3</sup> (2.43yd <sup>3</sup> )	1.60m <sup>3</sup> (2.1yd <sup>3</sup> )	1620mm (63.8")	1750mm (68.9")	1390kg (3060lb)						
2.10m <sup>3</sup> (2.75yd <sup>3</sup> )	1.80m <sup>3</sup> (2.4yd <sup>3</sup> )	1810mm (71.3")	1940mm (76.4")	1520kg (3350lb)						
2.32m <sup>3</sup> (3.03yd <sup>3</sup> )	2.0m <sup>3</sup> (2.6yd <sup>3</sup> )	1990mm (78.3")	2120mm (83.5")	1760kg (3880lb)						

※ : Standard bucket

 Applicable for materials with density of 2000kg/m<sup>3</sup> (3370lb/yd<sup>3</sup>) or less

 Applicable for materials with density of 1600kg/m<sup>3</sup> (2700lb/yd<sup>3</sup>) or less

 Applicable for materials with density of 1100kg/m<sup>3</sup> (1850lb/yd<sup>3</sup>) or less

## 2) ROCK AND HEAVY DUTY BUCKET

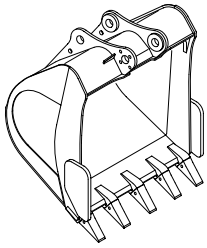
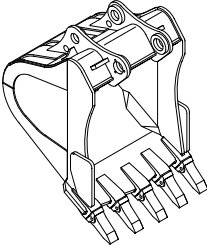
	
<p>◆ 1.62m<sup>3</sup> SAE heaped bucket</p>	<p>◎ 1.44m<sup>3</sup>, 1.62m<sup>3</sup>, 1.86m<sup>3</sup> SAE heaped bucket</p>

Capacity		Width		Weight	6.5m (21' 4") boom				6.15m (20' 2") boom
SAE heaped	CECE heaped	Without side cutter	With side cutter		2.5m arm (8' 2")	3.2m arm (10' 6")	3.9m arm (12' 10")	4.3m arm (14' 1")	2.5m arm (8' 2")
◆ 1.62m <sup>3</sup> (2.12yd <sup>3</sup> )	1.40m <sup>3</sup> (1.8yd <sup>3</sup> )	1540mm (60.6")	-	1570kg (3460lb)					
◎ 1.44m <sup>3</sup> (1.88yd <sup>3</sup> )	1.27m <sup>3</sup> (1.66yd <sup>3</sup> )	1280mm (50.4")	-	1565kg (3450lb)					
◎ 1.62m <sup>3</sup> (2.12yd <sup>3</sup> )	1.40m <sup>3</sup> (1.8yd <sup>3</sup> )	1545mm (60.8")	-	1610kg (3550lb)					
◎ 1.86m <sup>3</sup> (2.43yd <sup>3</sup> )	1.60m <sup>3</sup> (2.1yd <sup>3</sup> )	1725mm (67.9")	-	1710kg (3770lb)					

◆ : Heavy duty bucket

◎ : Rock bucket

Applicable for materials with density of 2000kgf/m<sup>3</sup> (3370lbf/yd<sup>3</sup>) or less

Applicable for materials with density of 1600kgf/m<sup>3</sup> (2700lbf/yd<sup>3</sup>) or less

Applicable for materials with density of 1100kgf/m<sup>3</sup> (1850lbf/yd<sup>3</sup>) or less

## 7. UNDERCARRIAGE

### 1) TRACKS

X-leg type center frame is integrally welded with reinforced box-section track frames. The design includes dry tracks, lubricated rollers, idlers, sprockets, hydraulic track adjusters with shock absorbing springs and assembled track-type tractor shoes with triple grousers.

### 2) TYPES OF SHOES

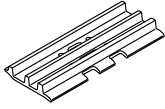
Model	Shapes		Triple grouser				
							
R360LC-7A	Shoe width	mm(in)	600(24)	700(28)	750(30)	800(32)	900(36)
	Operating weight	kg(lb)	36100(79590)	36500(80600)	36725(81000)	36950(81500)	37400(82500)
	Ground pressure	kgf/cm <sup>2</sup> (psi)	0.64(9.10)	0.56(7.96)	0.52(7.39)	0.49(6.97)	0.44(6.26)
	Overall width	mm(ft-in)	3340(10' 11")	3440(11' 3")	3490(11' 5")	3540(11' 7")	3640(11' 11")

### 3) NUMBER OF ROLLERS AND SHOES ON EACH SIDE

Item	Quantity
Carrier rollers	2EA
Track rollers	9EA
Track shoes	51EA

### 4) SELECTION OF TRACK SHOE

Suitable track shoes should be selected according to operating conditions.

#### Method of selecting shoes

Confirm the category from the list of applications in **table 2**, then use **table 1** to select the shoe. Wide shoes(Categories B and C) have limitations on applications. Before using wide shoes, check the precautions, then investigate and study the operating conditions to confirm if these shoes are suitable.

Select the narrowest shoe possible to meet the required flotation and ground pressure. Application of wider shoes than recommendations will cause unexpected problem such as bending of shoes, crack of link, breakage of pin, loosening of shoe bolts and the other various problems.

※ **Table 1**

Track shoe	Specification	Category
600mm triple grouser	Standard	A
700mm triple grouser	Option	B
750mm triple grouser	Option	B
800mm triple grouser	Option	C
900mm triple grouser	Option	C



※ **Table 2**

Category	Applications	Precautions
A	Rocky ground, river beds, normal soil	<ul style="list-style-type: none"> <li>• Travel at low speed on rough ground with large obstacles such as boulders or fallen trees</li> </ul>
B	Normal soil, soft ground	<ul style="list-style-type: none"> <li>• These shoes cannot be used on rough ground with large obstacles such as boulders or fallen trees</li> <li>• Travel at high speed only on flat ground</li> <li>• Travel slowly at low speed if it is impossible to avoid going over obstacles</li> </ul>
C	Extremely soft ground (Swampy ground)	<ul style="list-style-type: none"> <li>• Use the shoes only in the conditions that the machine sinks and it is impossible to use the shoes of category A or B</li> <li>• These shoes cannot be used on rough ground with large obstacles such as boulders or fallen trees</li> <li>• Travel at high speed only on flat ground</li> <li>• Travel slowly at low speed if it is impossible to avoid going over obstacles</li> </ul>



## 8. SPECIFICATIONS FOR MAJOR COMPONENTS

### 1) ENGINE

Item	Specification
Model	Cummins QSL
Type	4-cycle turbocharged charger air cooled diesel engine
Cooling method	Water cooling
Number of cylinders and arrangement	6 cylinders, in-line
Firing order	1-5-3-6-2-4
Combustion chamber type	Direct injection type
Cylinder bore × stroke	114 × 144.5mm(4.49" × 5.69")
Piston displacement	8900cc(540cu in)
Compression ratio	17.8 : 1
Rated gross horse power(SAE J1995)	296Hp at 1850rpm(221kW at 1850rpm)
Maximum torque	138.3kgf · m(1000lb · ft) at 1400rpm
Engine oil quantity	31.7 l (8.4U.S. gal)
Dry weight	738kg(1630lb)
Low idling speed	700 ± 100rpm
High idling speed	1850 + 50rpm
Rated fuel consumption	164.8g/Hp · hr at 1850rpm
Starting motor	Denso 24V-7.5kW
Alternator	Delco Remy 24V-50A
Battery	2 × 12V × 160Ah

### 2) MAIN PUMP

Item	Specification
Type	Variable displacement tandem axis piston pumps
Capacity	2 × 160cc/rev
Maximum pressure	330kgf/cm <sup>2</sup> (4690psi)[360kgf/cm <sup>2</sup> (5120psi)]
Rated oil flow	2 × 288 l /min (76.1U.S. gpm/ 63.3U.K. gpm)
Rated speed	1800rpm

[ ]: Power boost

### 3) GEAR PUMP

Item	Specification
Type	Fixed displacement gear pump single stage
Capacity	15cc/rev
Maximum pressure	35kgf/cm <sup>2</sup> (500psi)
Rated oil flow	27 l /min(7.1U.S. gpm/5.9U.K. gpm)

### 4) MAIN CONTROL VALVE

Item	Specification
Type	7 spools
Operating method	Hydraulic pilot system
Main relief valve pressure	330kgf/cm <sup>2</sup> (4690psi) [360kgf/cm <sup>2</sup> (5120psi)]
Overload relief valve pressure	390kgf/cm <sup>2</sup> (5550psi)

[ ]: Power boost

### 5) SWING MOTOR

Item	Specification
Type	Axial piston motor
Capacity	250cc/rev
Relief pressure	260kgf/cm <sup>2</sup> (3700psi)
Braking system	Automatic, spring applied hydraulic released
Braking torque	107kgf · m(773lbf · ft)
Brake release pressure	30~50kgf/cm <sup>2</sup> (427~711psi)
Reduction gear type	2 - stage planetary
Swing speed	9.0rpm

### 6) TRAVEL MOTOR

Item	Specification
Type	Variable displacement axial piston motor
Relief pressure	360kgf/cm <sup>2</sup> (5120psi)
Capacity(max / min)	185.2/114.2cc/rev
Reduction gear type	3-stage planetary
Braking system	Automatic, spring applied hydraulic released
Brake release pressure	8.5kgf/cm <sup>2</sup> (121psi)
Braking torque	44.4kgf · m(321lbf · ft)

## 7) REMOTE CONTROL VALVE

Item		Specification
Type		Pressure reducing type
Operating pressure	Minimum	6.5kgf/cm <sup>2</sup> (92psi)
	Maximum	26kgf/cm <sup>2</sup> (370psi)
Single operation stroke	Lever	61mm(2.4in)
	Pedal	123mm(4.84in)

## 8) CYLINDER

Item		Specification
Boom cylinder	Bore dia × Rod dia × Stroke	∅ 160 × ∅ 110 × 1500mm
	Cushion	Extend only
Arm cylinder	Bore dia × Rod dia × Stroke	∅ 170 × ∅ 120 × 1760mm
	Cushion	Extend and retract
Bucket cylinder	Bore dia × Rod dia × Stroke	∅ 150 × ∅ 105 × 1295mm
	Cushion	Extend only

※ Discoloration of cylinder rod can occur when the friction reduction additive of lubrication oil spreads on the rod surface.

※ Discoloration does not cause any harmful effect on the cylinder performance.

## 9) SHOE

Item		Width	Ground pressure	Link quantity	Overall width
R360LC-7A	Standard	600mm(24")	0.64kgf/cm <sup>2</sup> (9.10psi)	51	3340mm(10' 11")
	Option	700mm(28")	0.56kgf/cm <sup>2</sup> (7.96psi)	51	3440mm(11' 3")
		750mm(30")	0.52kgf/cm <sup>2</sup> (7.39psi)	51	3490mm(11' 5")
		800mm(32")	0.49kgf/cm <sup>2</sup> (6.97psi)	51	3540mm(11' 7")
		900mm(36")	0.44kgf/cm <sup>2</sup> (6.26psi)	51	3640mm(11' 11")

## 10) BUCKET

Item		Capacity		Tooth quantity	Width		
		SAE heaped	CECE heaped		Without side cutter	With side cutter	
R360LC-7A	Standard	1.62m <sup>3</sup> (2.12yd <sup>3</sup> )	1.40m <sup>3</sup> (1.8yd <sup>3</sup> )	5	1440mm(56.7")	1570mm(61.8")	
	Option		1.15m <sup>3</sup> (1.50yd <sup>3</sup> )	1.0m <sup>3</sup> (1.3yd <sup>3</sup> )	4	1090mm(42.9")	1220mm(48.0")
			1.46m <sup>3</sup> (1.91yd <sup>3</sup> )	1.27m <sup>3</sup> (1.66yd <sup>3</sup> )	4	1380mm(54.3")	1510mm(59.4")
		◆	1.62m <sup>3</sup> (2.12yd <sup>3</sup> )	1.40m <sup>3</sup> (1.8yd <sup>3</sup> )	5	1540mm(60.6")	-
		◎	1.44m <sup>3</sup> (1.88yd <sup>3</sup> )	1.27m <sup>3</sup> (1.66yd <sup>3</sup> )	5	1280mm(50.4")	-
		◎	1.62m <sup>3</sup> (2.12yd <sup>3</sup> )	1.40m <sup>3</sup> (1.8yd <sup>3</sup> )	5	1545mm(60.8")	-
		◎	1.86m <sup>3</sup> (2.43yd <sup>3</sup> )	1.60m <sup>3</sup> (2.1yd <sup>3</sup> )	5	1725mm(67.9")	-
			1.86m <sup>3</sup> (2.43yd <sup>3</sup> )	1.60m <sup>3</sup> (2.1yd <sup>3</sup> )	5	1620mm(63.8")	1750mm(68.9")
			2.10m <sup>3</sup> (2.75yd <sup>3</sup> )	1.80m <sup>3</sup> (2.4yd <sup>3</sup> )	6	1810mm(71.3")	1940mm(76.4")
			2.32m <sup>3</sup> (3.03yd <sup>3</sup> )	2.0m <sup>3</sup> (2.6yd <sup>3</sup> )	6	1990mm(78.3")	2120mm(83.5")

◆ : Heavy duty bucket

◎ : Rock bucket(Esco type)

## 9. RECOMMENDED OILS

Use only oils listed below or equivalent.

Do not mix different brand oil.

Service point	Kind of fluid	Capacity l (U.S. gal)	Ambient temperature °C (°F)						
			-20 (-4)	-10 (14)	0 (32)	10 (50)	20 (68)	30 (86)	40 (104)
Engine oil pan	Engine oil	31.7(8.4)	SAE 30						
			SAE 10W						
			SAE 10W-30						
							SAE 15W-40		
Swing drive	Gear oil	8.0(2.1)	SAE 85W-140						
Final drive		5.5 × 2 (1.5 × 2)							
Hydraulic tank	Hydraulic oil	Tank; 230(61)	ISO VG 32						
		System; 380(100)	ISO VG 46						
			ISO VG 68						
Fuel tank	Diesel fuel	520(137)	ASTM D975 NO.1						
			ASTM D975 NO.2						
Fitting (Grease nipple)	Grease	As required	NLGI NO.1						
			NLGI NO.2						
Radiator (Reservoir tank)	Mixture of antifreeze and water 50 : 50	45(12)	Ethylene glycol base permanent type						

**SAE** : Society of Automotive Engineers

**API** : American Petroleum Institute

**ISO** : International Organization for Standardization

**NLGI** : National Lubricating Grease Institute

**ASTM** : American Society of Testing and Material