

# GROUP 2 ENGINE SYSTEM

## ENGINE AND ACCESSORIES MOUNTING

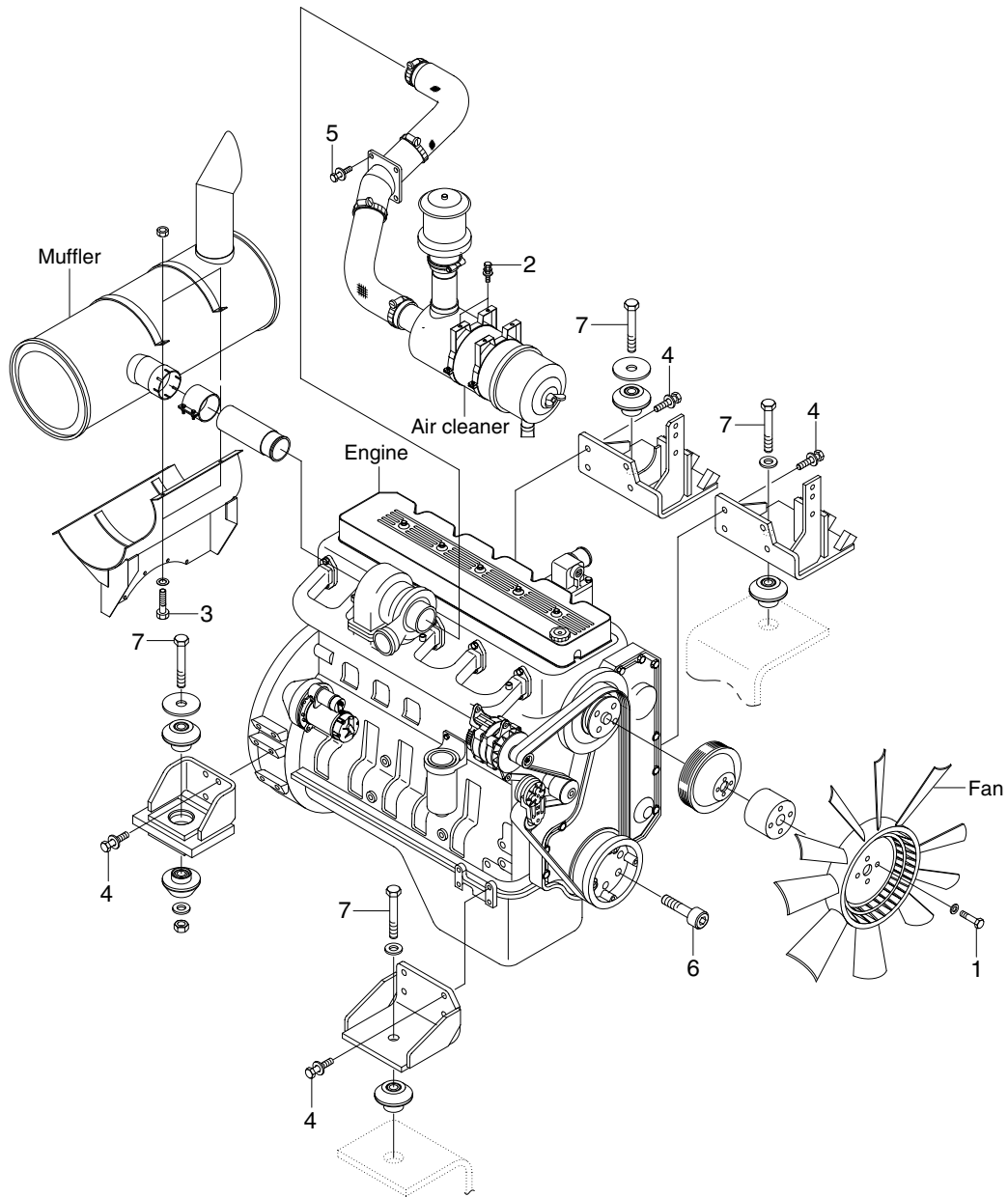

3607A9CM01

### · Tightening torque

Item	Size	kgf · m	lbf · ft
1	M10×1.5	4.4±0.9	31.8±6.5
2	M10×1.5	5.0±1.0	36.2±7.2
3	M10×1.5	6.9±1.4	49.9±10.1
4	M12×1.75	10.0±2.0	72.3±14.5

Item	Size	kgf · m	lbf · ft
5	M12×1.75	12.8±3.0	92.6±21.7
6	M12×1.75	14.7±2.2	106±15.9
7	M24×3.0	90±7.0	651±51
-	-	-	-

# COOLING SYSTEM AND FUEL TANK MOUNTING

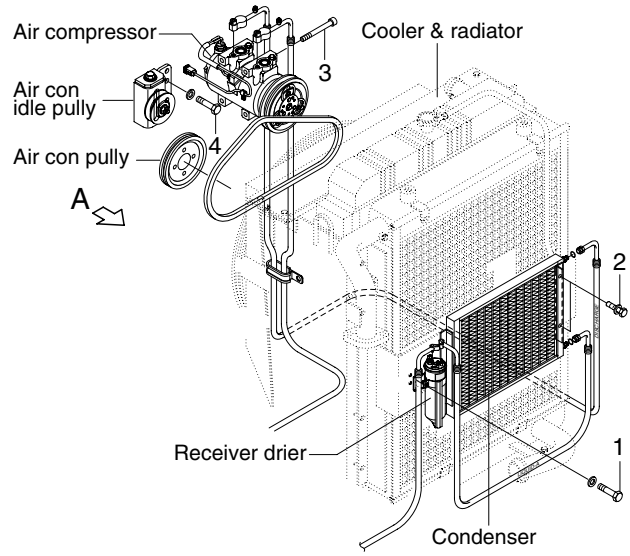
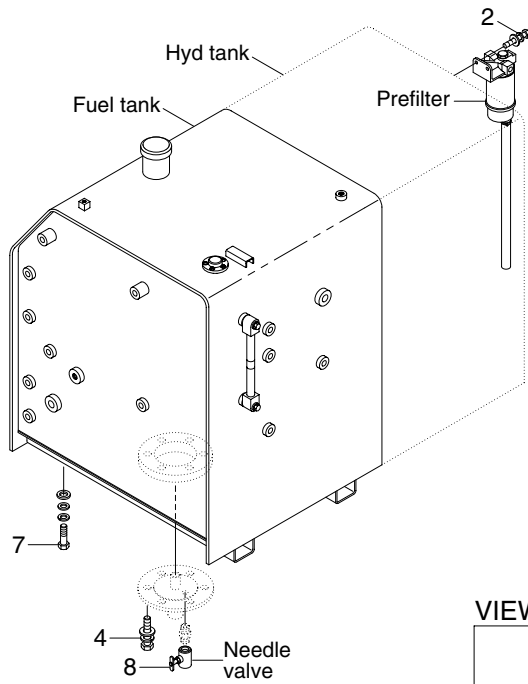

VIEW A

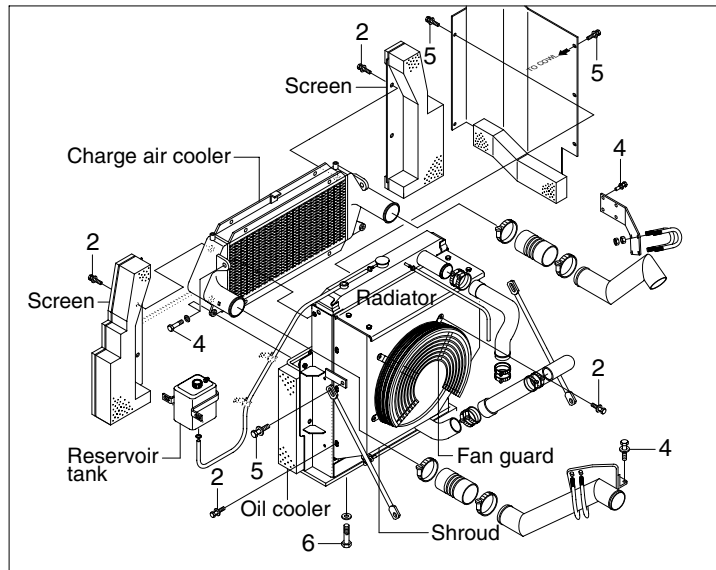

3607A9CM02

## · Tightening torque

Item	Size	kgf · m	lbf · ft
1	M 6×1.0	1.05±0.2	7.6±1.45
2	M 8×1.25	2.5±0.5	18.1±3.6
3	M 8×1.25	4.05±0.8	29.3±5.8
4	M10×1.5	6.9±1.4	49.9±10.1

Item	Size	kgf · m	lbf · ft
5	M12×1.75	12.8±3.0	92.6±21.7
6	M16×2.0	29.7±4.5	215±32.5
7	M20×2.5	46±5.0	333±36
8	-	2.3±0.6	16.6±4.3