

GROUP 2 ELECTRICAL CIRCUIT

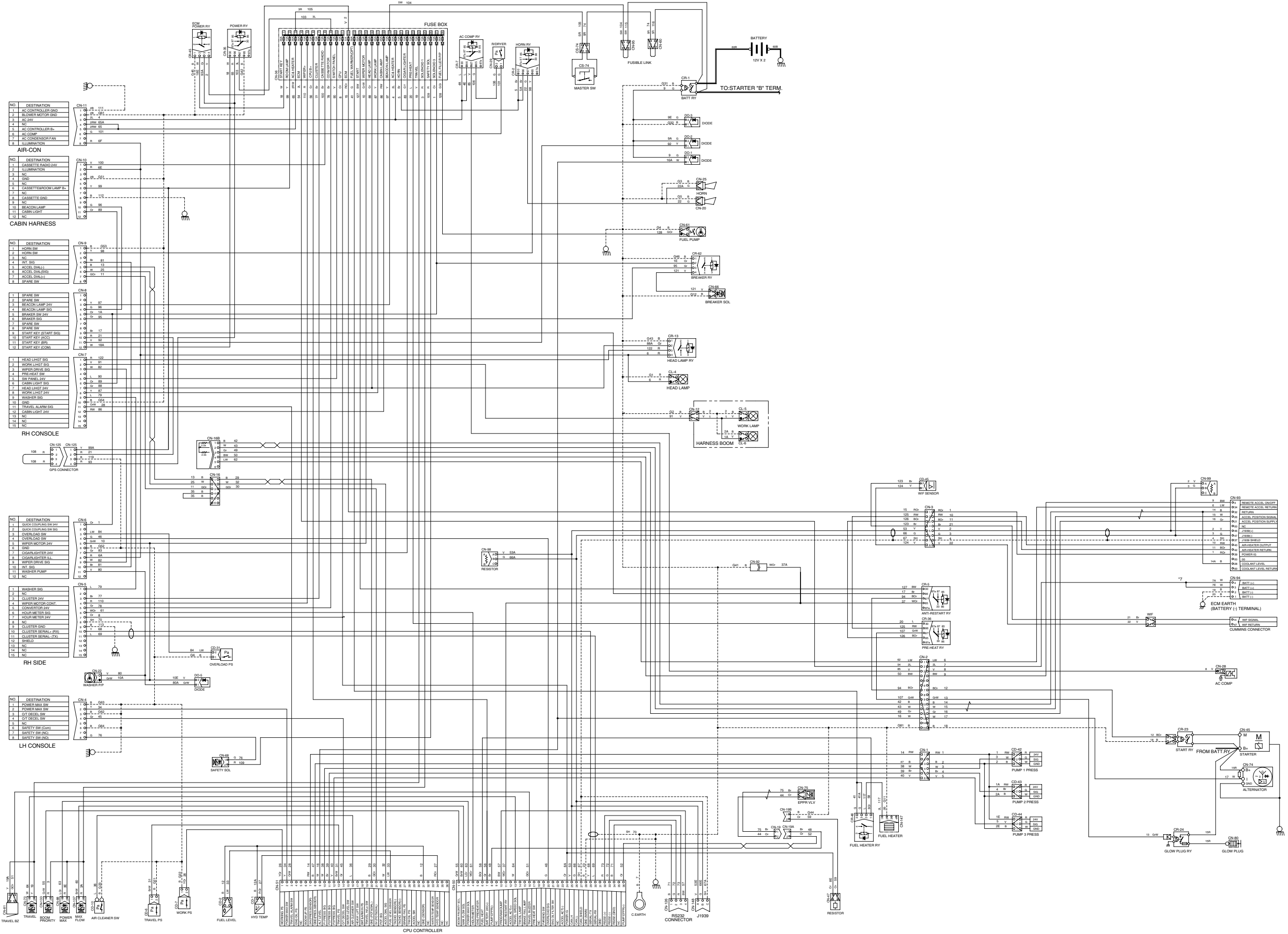

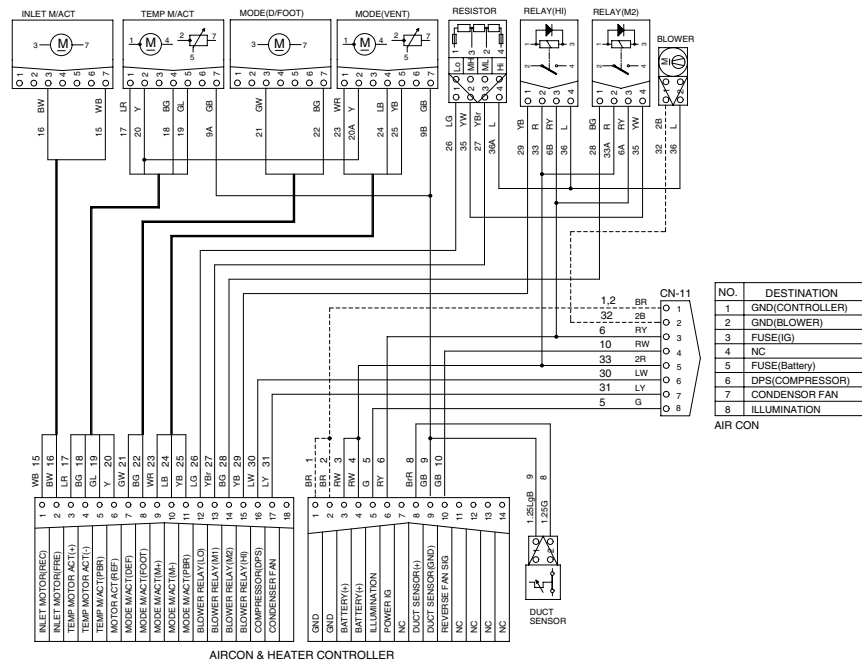

NO.	DESTINATION
1	GND(CONTROLLER)
2	GND(BLOWER)
3	FUSE(S)
4	NC
5	FUSE(Battery)
6	DPS(COMPRESSOR)
7	CONDENSOR FAN
8	ILLUMINATION

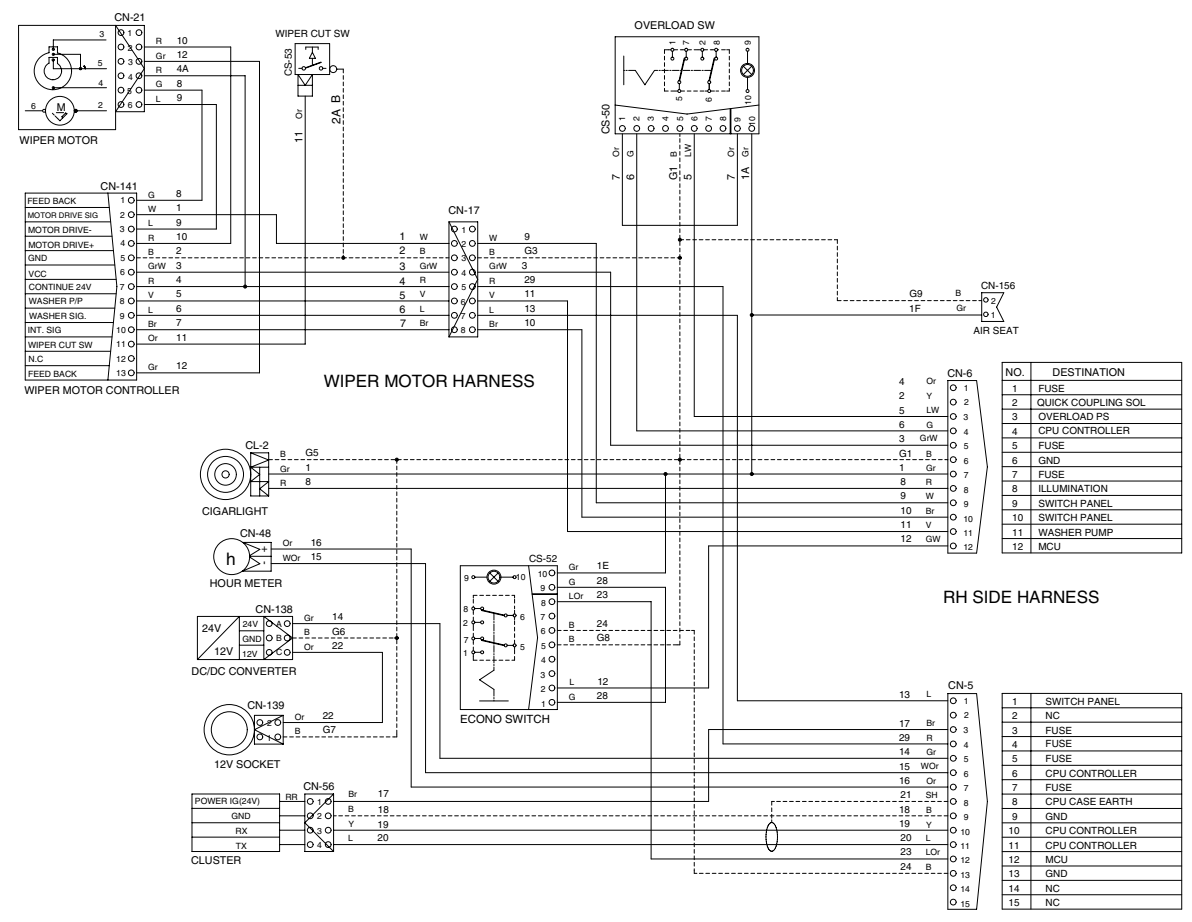

NO.	DESTINATION
1	FUSE
2	QUICK COUPLING SOL
3	OVERLOAD PS
4	CPU CONTROLLER
5	FUSE
6	GND
7	FUSE
8	ILLUMINATION
9	SWITCH PANEL
10	SWITCH PANEL
11	WASHER PUMP
12	MCU

NO.	DESTINATION
1	SWITCH PANEL
2	NC
3	FUSE
4	FUSE
5	FUSE
6	CPU CONTROLLER
7	FUSE
8	CPU CASE EARTH
9	GND
10	CPU CONTROLLER
11	CPU CONTROLLER
12	MCU
13	GND
14	NC
15	NC

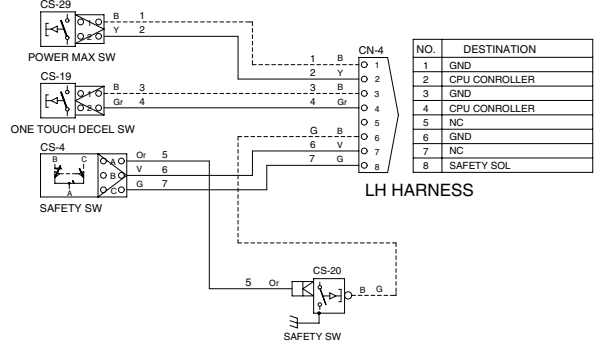

NO.	DESTINATION
1	GND
2	CPU CONTROLLER
3	GND
4	CPU CONTROLLER
5	NC
6	GND
7	NC
8	SAFETY SOL

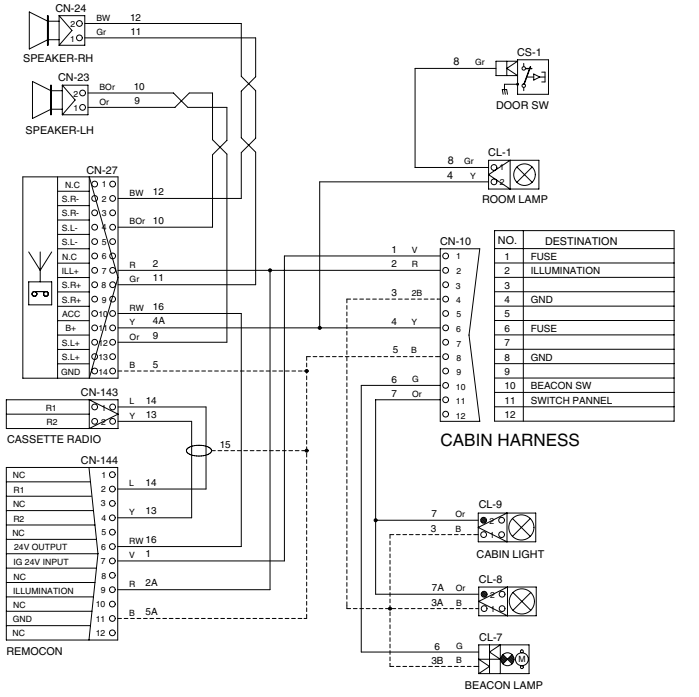

NO.	DESTINATION
1	FUSE
2	ILLUMINATION
3	
4	GND
5	FUSE
6	GND
7	
8	GND
9	
10	BEACON SW
11	SWITCH PANNEL
12	

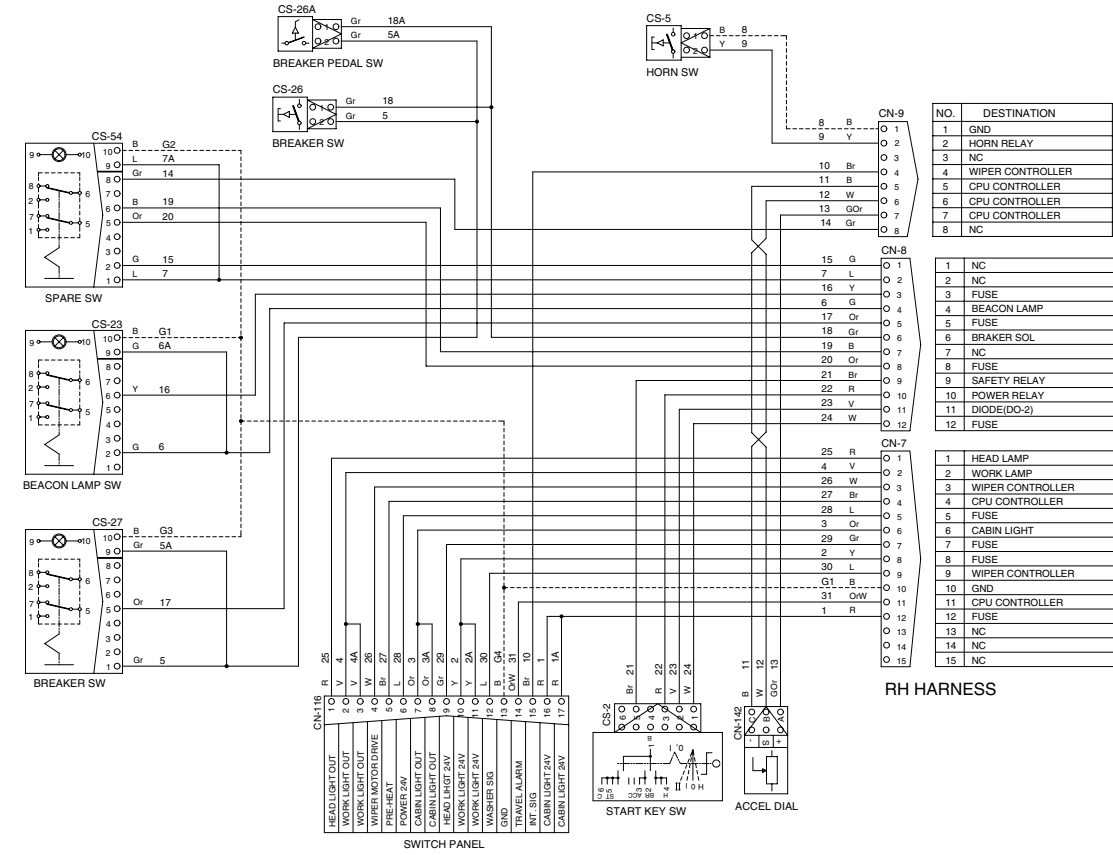

NO.	DESTINATION
1	GND
2	HORN RELAY
3	NC
4	WIPER CONTROLLER
5	CPU CONTROLLER
6	CPU CONTROLLER
7	CPU CONTROLLER
8	NC

NO.	DESTINATION
1	NC
2	NC
3	FUSE
4	BEACON LAMP
5	FUSE
6	BRAKER SOL
7	NC
8	FUSE
9	SAFETY RELAY
10	POWER RELAY
11	DIODE(DO-2)
12	FUSE

NO.	DESTINATION
1	HEAD LAMP
2	WORK LAMP
3	WIPER CONTROLLER
4	CPU CONTROLLER
5	FUSE
6	CABIN LIGHT
7	FUSE
8	FUSE
9	WIPER CONTROLLER
10	GND
11	CPU CONTROLLER
12	FUSE
13	NC
14	NC
15	NC

## 1. POWER CIRCUIT

The negative terminal of battery is grounded to the machine chassis.

When the start switch is in the OFF position, the current flows from the positive battery terminal as shown below.

### 1) OPERATING FLOW

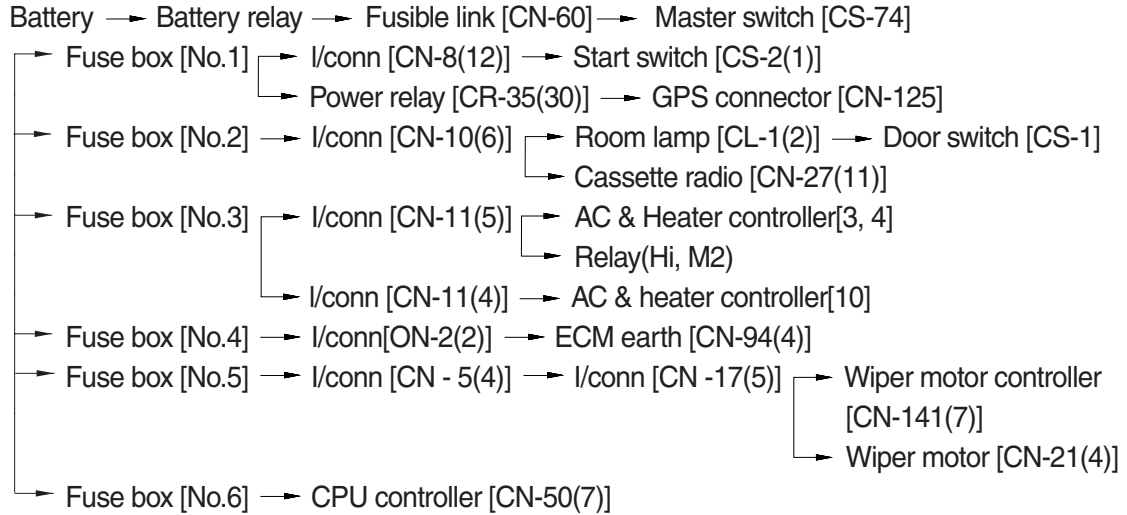

※ I/conn : Intermediate connector

### 2) CHECK POINT

Engine	Start switch	Check point	Voltage
OFF	OFF	① - GND (Battery 1EA)	10~12.5V
		② - GND (Battery 2EA)	20~25V
		③ - GND (Battery 2EA)	20~25V
		④ - GND (Fusible link)	20~25V

※ GND : Ground

# POWER CIRCUIT

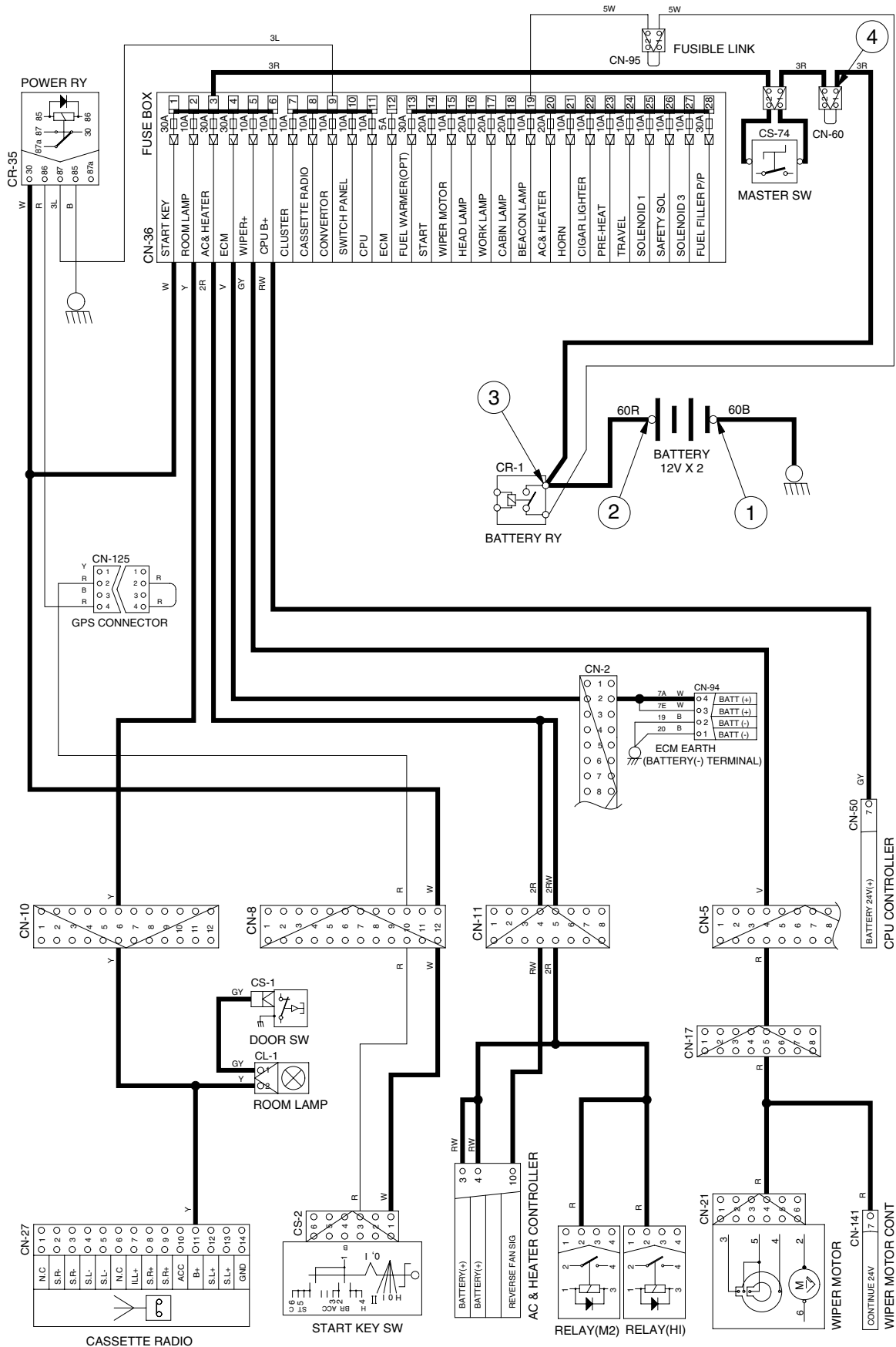

## 2. STARTING CIRCUIT

### 1) OPERATING FLOW

Battery(+) terminal → Battery relay [CR-1] → Fusible link [CN-60] → Master switch [CS-74]  
 → Fuse box [No.1] → I/conn [CN-8(12)] → Start switch [CS-2(1)]

#### (1) When start key switch is in ON position

→ Start switch ON [CS-2(2)] → I/conn [CN-8(11)] → Battery relay [CR-1]  
 → Battery relay operating (All power is supplied with the electric component)  
 → Start switch ON [CS-2(3)] → I/conn [CN-8(10)] → GPS connector [CN-125(2)→(4)]  
 → Power relay [CR-35(86)→(87)] → Fuse box [No.9]

#### (2) When start key switch is in START position

Start switch START [CS-2(5)] → I/conn [CN-8(9)] → Safety relay [CR-5(86)→(87)]  
 → I/conn [CN-2(7)] → Start relay [CR-23]

### 2) CHECK POINT

Engine	Start switch	Check point	Voltage
OPERATING	START	① - GND(Battery) ② - GND(Start key) ③ - GND(Battery relay M4) ④ - GND(Starter B <sup>+</sup> ) ⑤ - GND(Starter M) ⑥ - GND(Start relay) ⑦ - GND(Battery relay M8)	20~25V

※ GND : Ground

# STARTING CIRCUIT

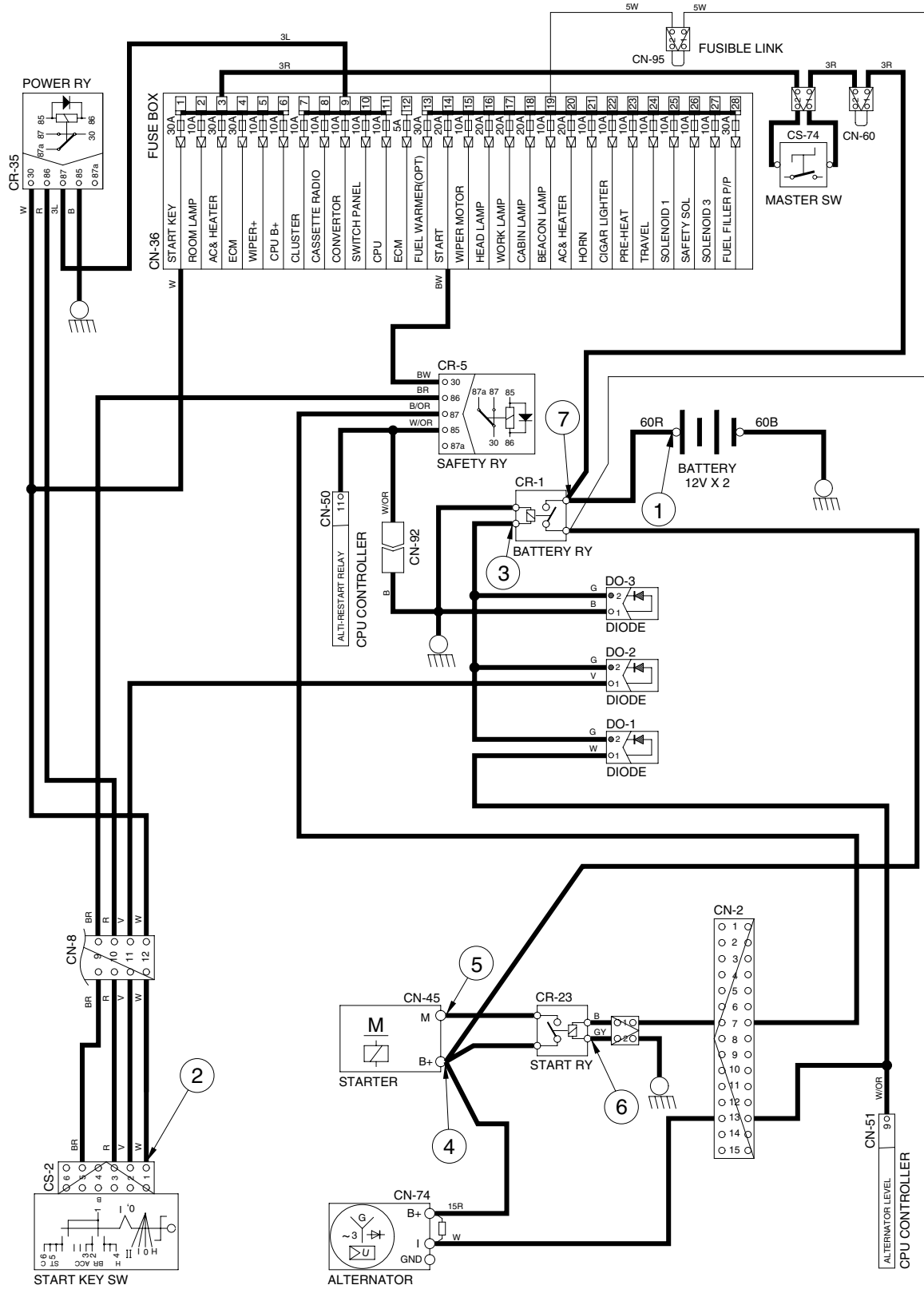

### 3. CHARGING CIRCUIT

When the starter is activated and the engine is started, the operator releases the key switch to the ON position.

Charging current generated by operating alternator flows into the battery through the battery relay (CR-1).

The current also flows from alternator to each electrical component and controller through the fuse box.

#### 1) OPERATING FLOW

##### (1) Warning flow

Alternator "I" terminal → I/conn [CN-2(13)] → CPU alternator level [CN-51(9)]  
Cluster charging warning lamp(Via serial interface)

##### (2) Charging flow

Alternator "B+" terminal → Battery relay(M8) → Battery(+) terminal  
→ Fusible link [CN-60] → Master switch [CS-74]  
→ Fuse box

#### 2) CHECK POINT

Engine	Start switch	Check point	Voltage
Run	ON	① - GND(Battery voltage) ② - GND(Battery relay) ③ - GND(Alternator B <sup>+</sup> terminal) ④ - GND(Alternator I terminal) ⑤ - GND(CPU)	20~30V

※ GND : Ground

# CHARGING CIRCUIT

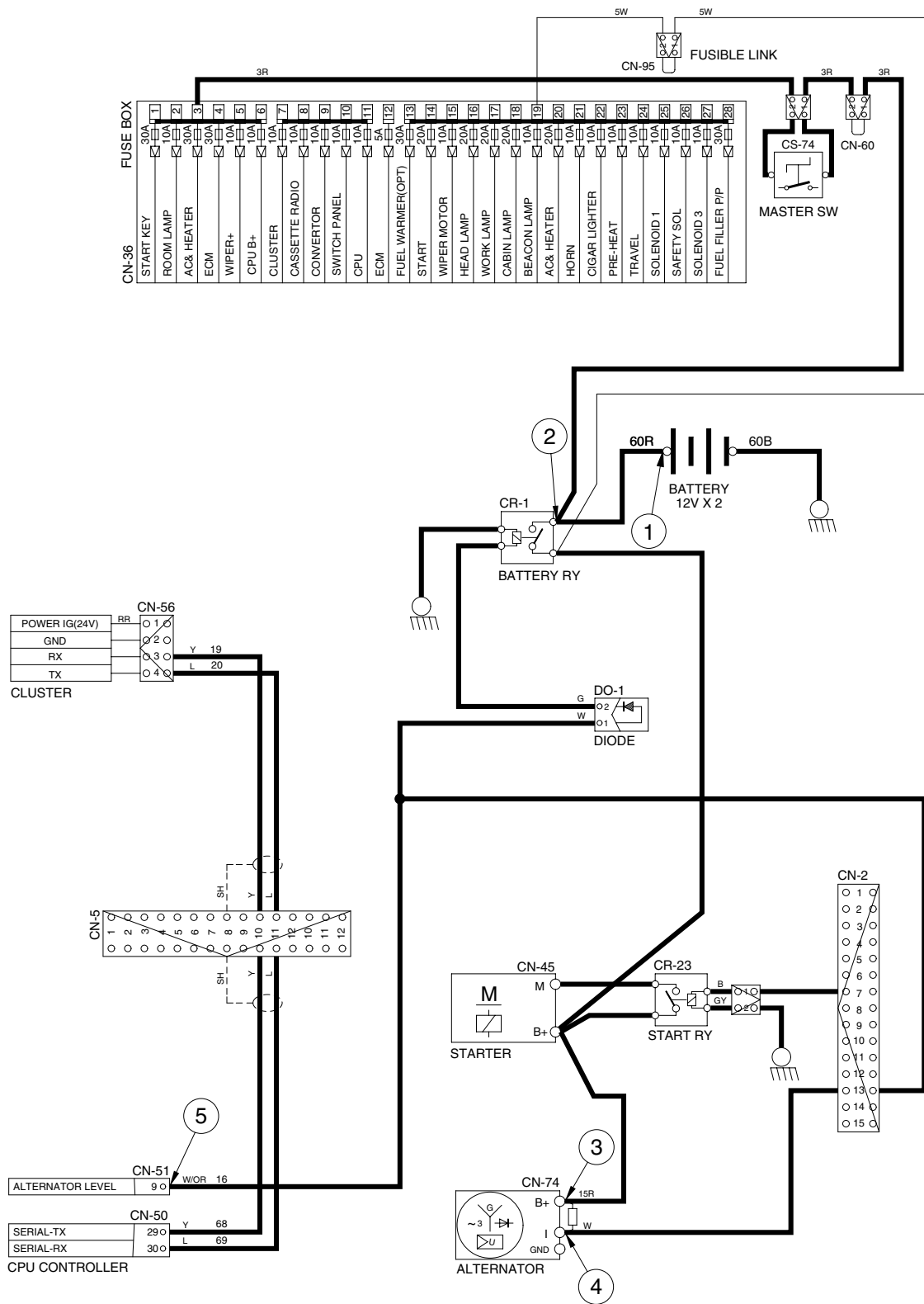

3607A4EL05



## 4. HEAD AND WORK LIGHT CIRCUIT

### 1) OPERATING FLOW

Fuse box (No.16) → I/conn [CN-7(7)] → Switch panel [CN-116(9)]

Fuse box (No.17) → I/conn [CN-7(8)] → Switch panel [CN-116(10,11)]

#### (1) Head light switch ON

Head light switch ON [CN-116(1)] → I/conn [CN-7(1)] → Head light relay [CR-13(3)]

- Head light ON [CL-4(1)]
- I/conn [CN-10(2)] → Cassette radio illumination ON [CN-27(7)]
- I/conn [CN-11(8)] → AC & Heater controller illumination ON(5)
- I/conn [CN-6(8)] → Cigarlight [CL-2]

#### (2) Work light switch ON

Work light switch ON [CN-116(2,3)] → I/conn [CN-7(2)] → I/conn [CN-12(1)]

→ Work light ON [CL-5(2), CL-6(2)]

### 2) CHECK POINT

Engine	Start switch	Check point	Voltage
STOP	ON	① - GND(Fuse box) ② - GND(Switch power input) ③ - GND(Switch power output) ④ - GND(Head light) ⑤ - GND(Head light relay)	20~25V
STOP	ON	⑥ - GND(Fuse box) ⑦ - GND(Switch power input) ⑧ - GND(Switch power output) ⑨ - GND(Work light)	20~25V

※ GND : Ground

# HEAD AND WORK LIGHT CIRCUIT

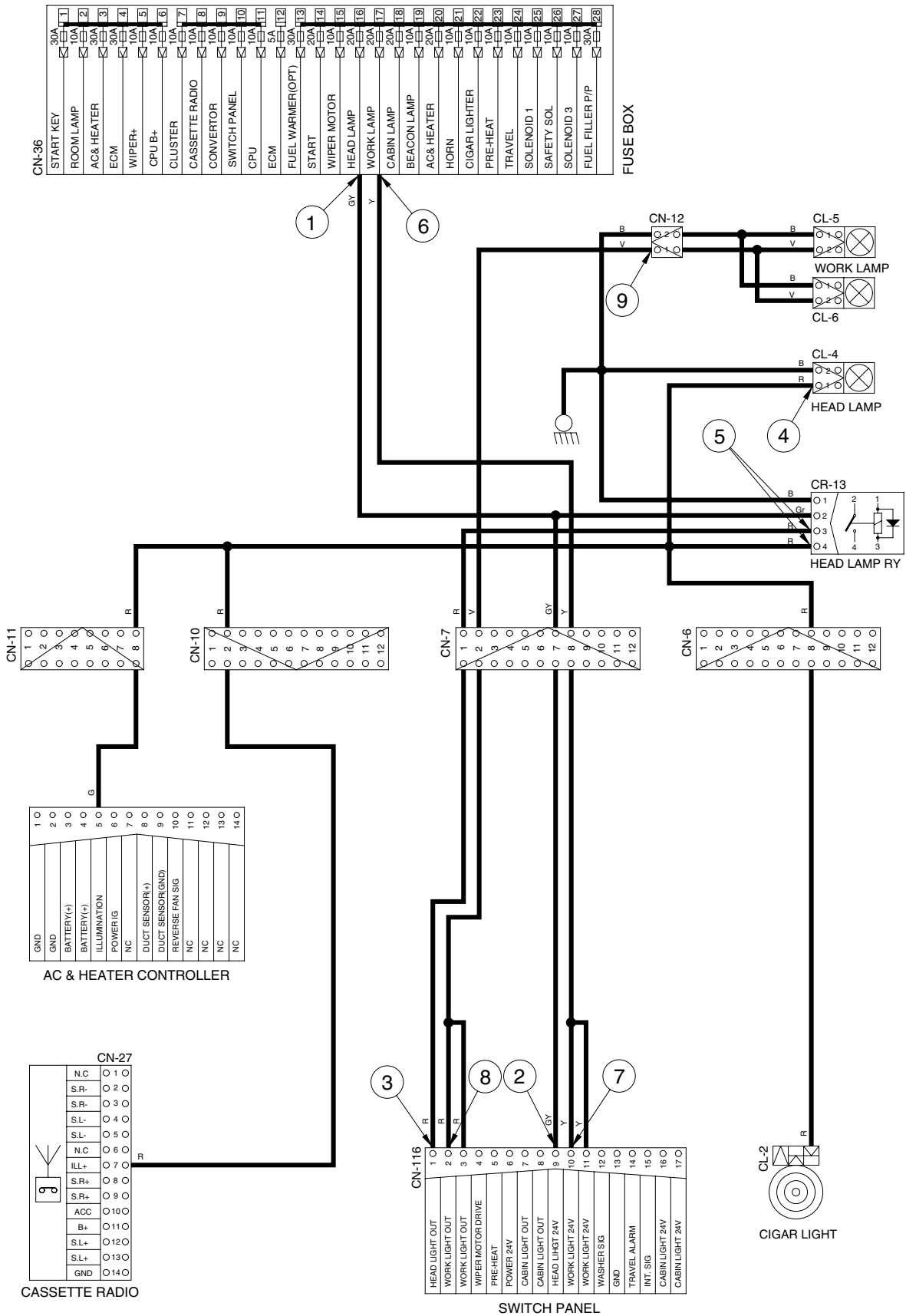

## 5. BEACON LAMP AND CAB LIGHT CIRCUIT

### 1) OPERATING FLOW

Fuse box (No.19) → I/conn [CN-8(3)] → Beacon lamp switch [CN-23(6)]

Fuse box (No.18) → I/conn [CN-7(12)] → Switch panel [CN-116(16, 17)]

#### (1) Beacon lamp switch ON

Beacon lamp switch ON [CS-23(2)] → Switch Indicator lamp ON [CS-23(9)]  
 → I/conn [CN-8(4)] → I/conn [CN-10(10)]  
 → Beacon lamp ON [CL-7]

#### (2) Cab light switch ON

Cab light switch ON [CN-116(7, 8)] → I/conn [CN-7(6)] → I/conn [CN-10(11)]

→ Cab light ON [CL-8(2), CL-9(2)]

### 2) CHECK POINT

Engine	Start switch	Check point	Voltage
STOP	ON	① - GND(Fuse box) ② - GND(Switch power input) ③ - GND(Switch power output) ④ - GND(Beacon lamp)	20~25V
STOP	ON	⑤ - GND(Fuse box) ⑥ - GND(Switch power input) ⑦ - GND(Switch power output) ⑧ - GND(Cab light)	20~25V

※ GND : Ground

# BEACON LAMP AND CAB LIGHT CIRCUIT

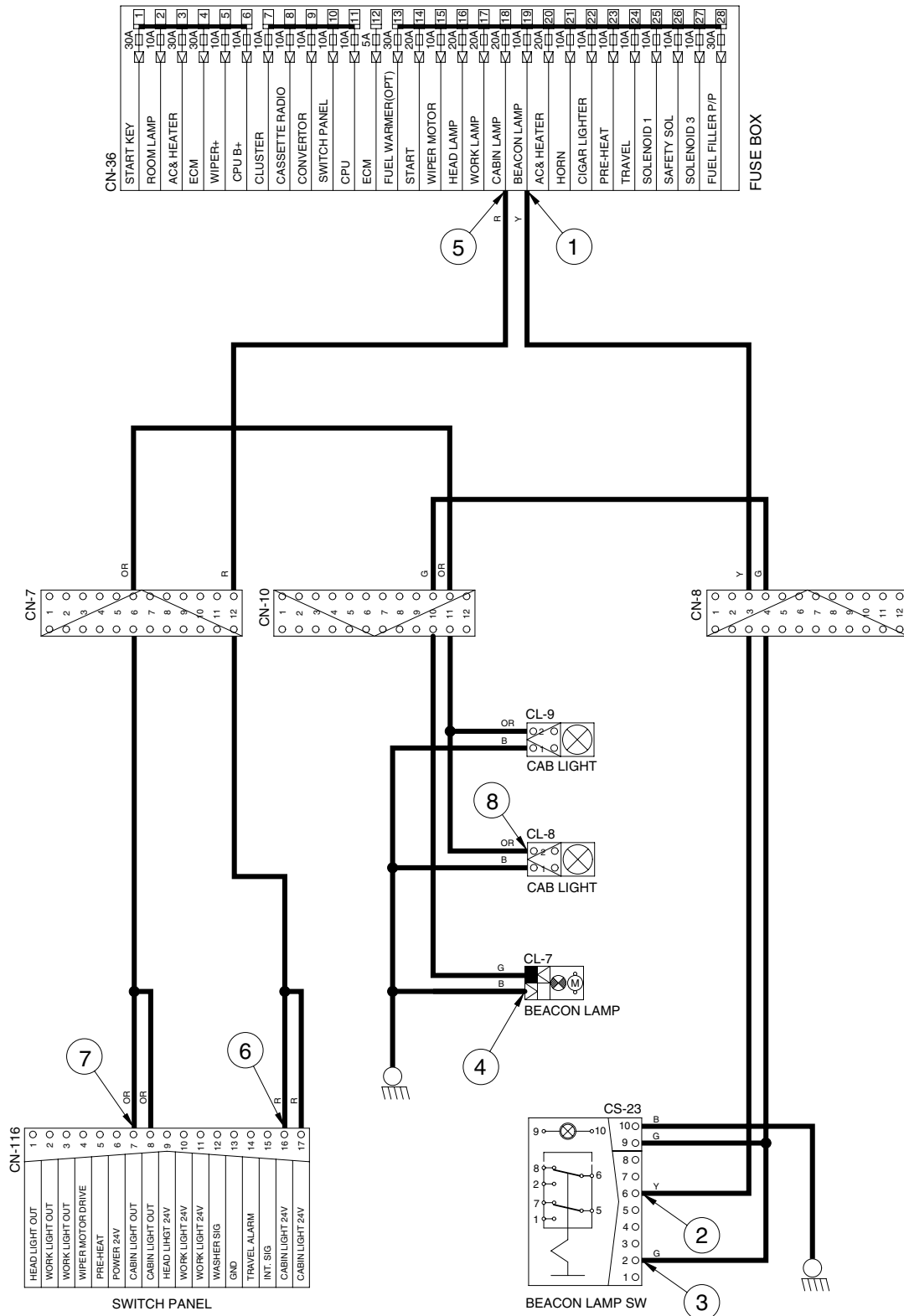

3607A4EL07

## 6. WIPER AND WASHER CIRCUIT

### 1) OPERATING FLOW

#### (1) Key switch ON

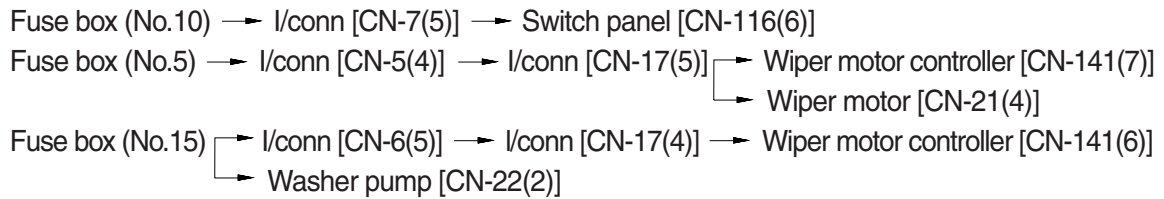

#### (2) Wiper switch ON : 1st step(Intermittent)

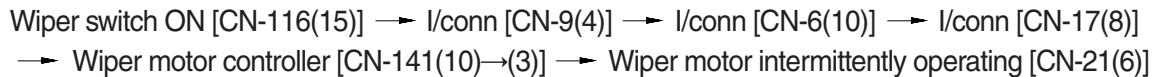

#### (3) Wiper switch ON : 2nd step(Low speed)

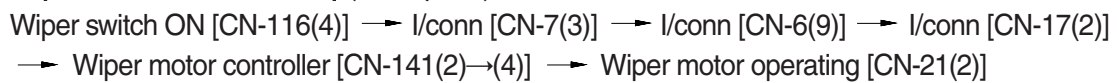

#### (4) Washer switch ON

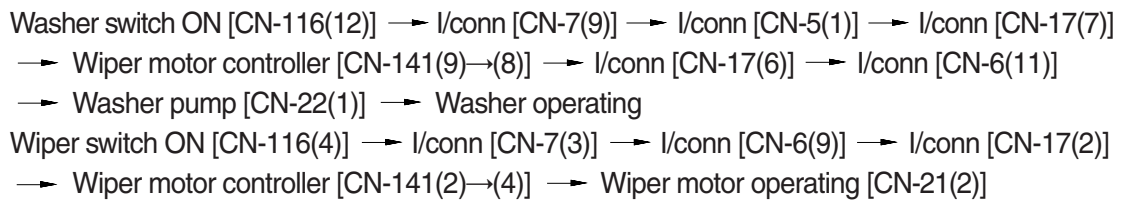

#### (5) Auto parking(When switch OFF)



### 2) CHECK POINT

Engine	Start switch	Check point	Voltage
STOP	ON	① - GND(Fuse box)	24V
		② - GND(Switch power input)	
		③ - GND(Switch power output)	0~5V
		④ - GND(Wiper Power input)	
		⑤ - GND(Wiper power output)	24V
		⑥ - GND(Wiper motor)	

※ GND : Ground

# WIPER AND WASHER CIRCUIT

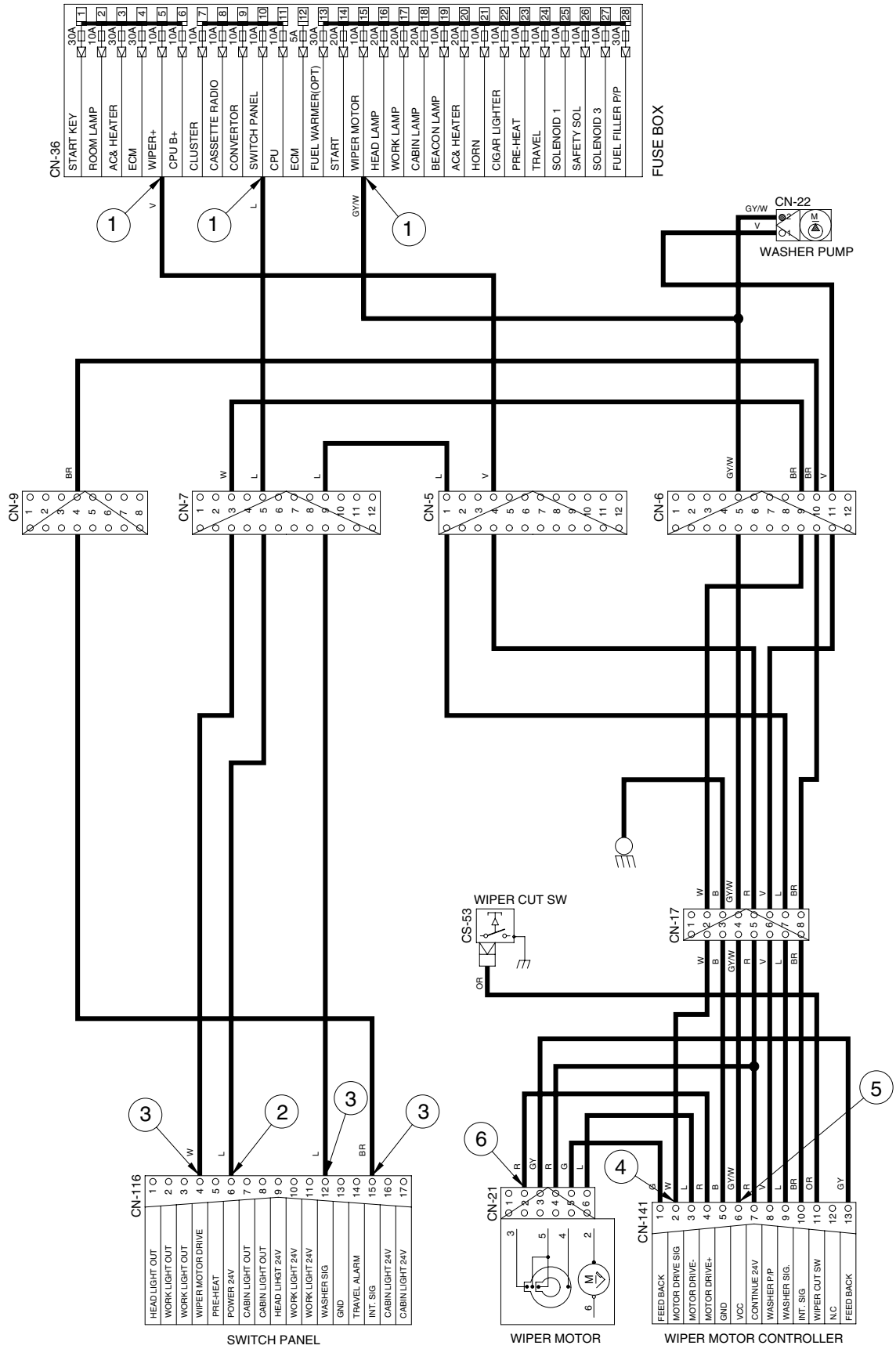

3607A4EL08

# CONTROLLER CIRCUIT

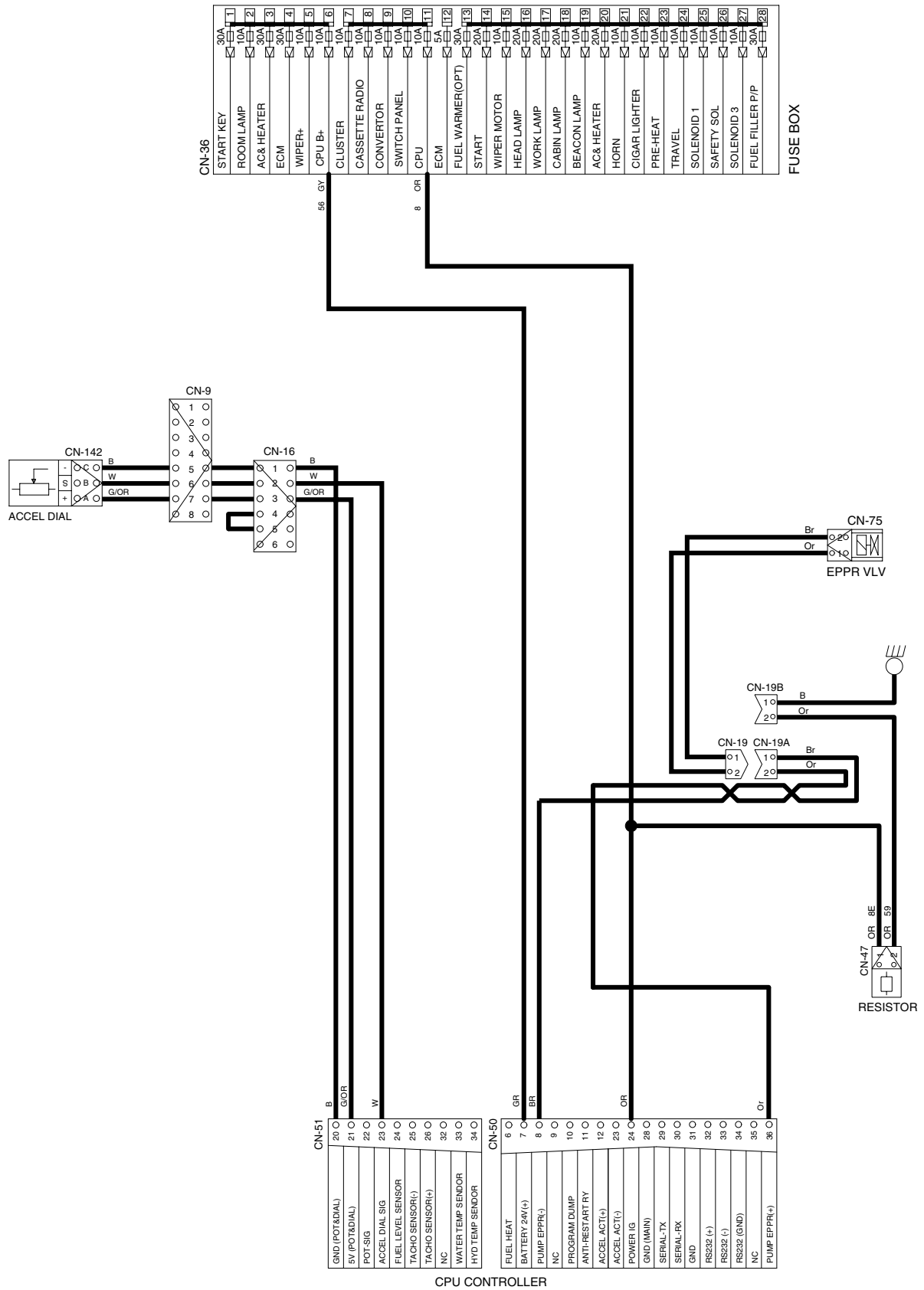

3607A4EL09

# ELECTRIC CIRCUIT FOR HYDRAULIC

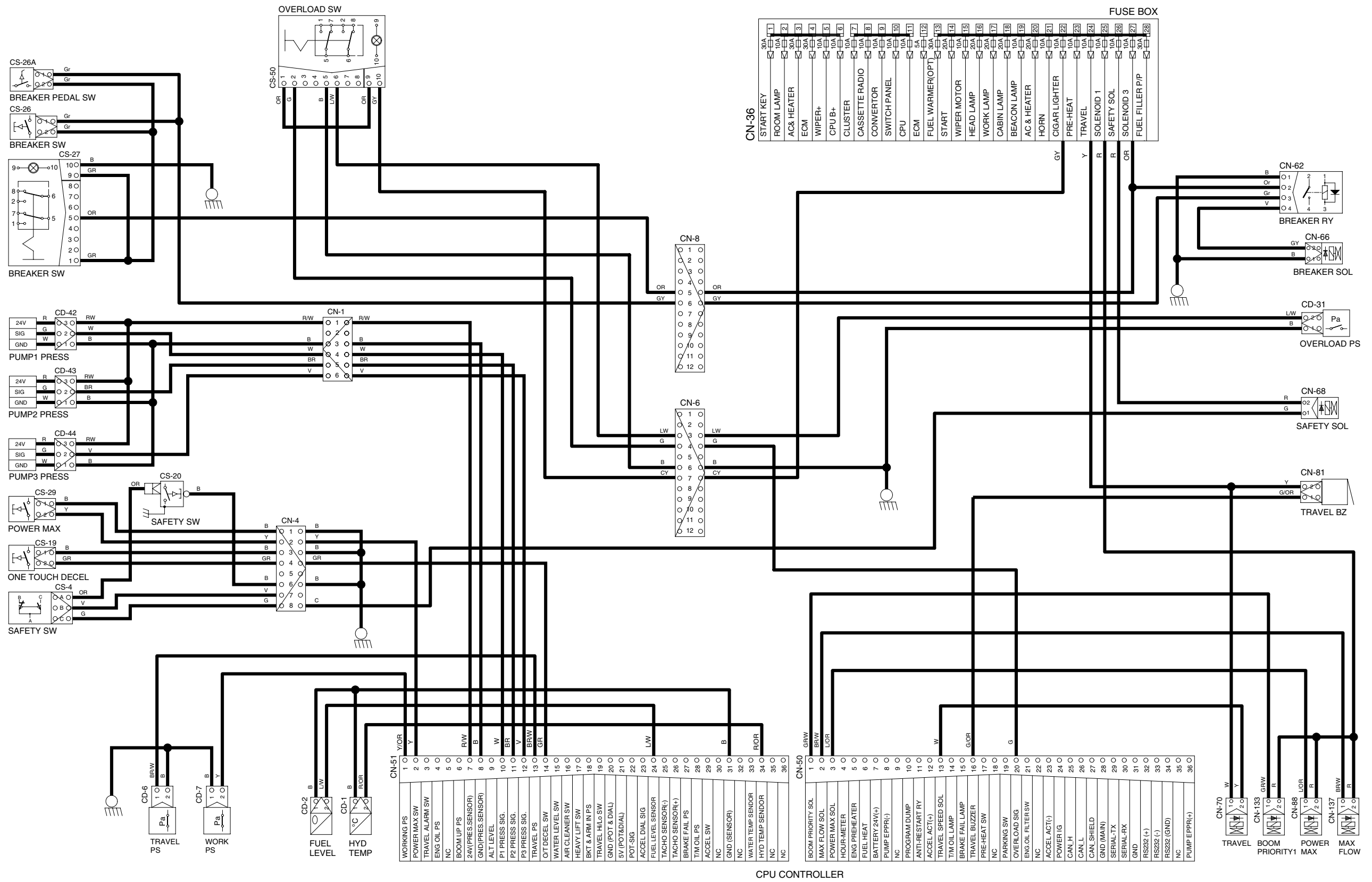



# MONITORING CIRCUIT

