

GROUP 3 AUTOMATIC DECELERATION SYSTEM

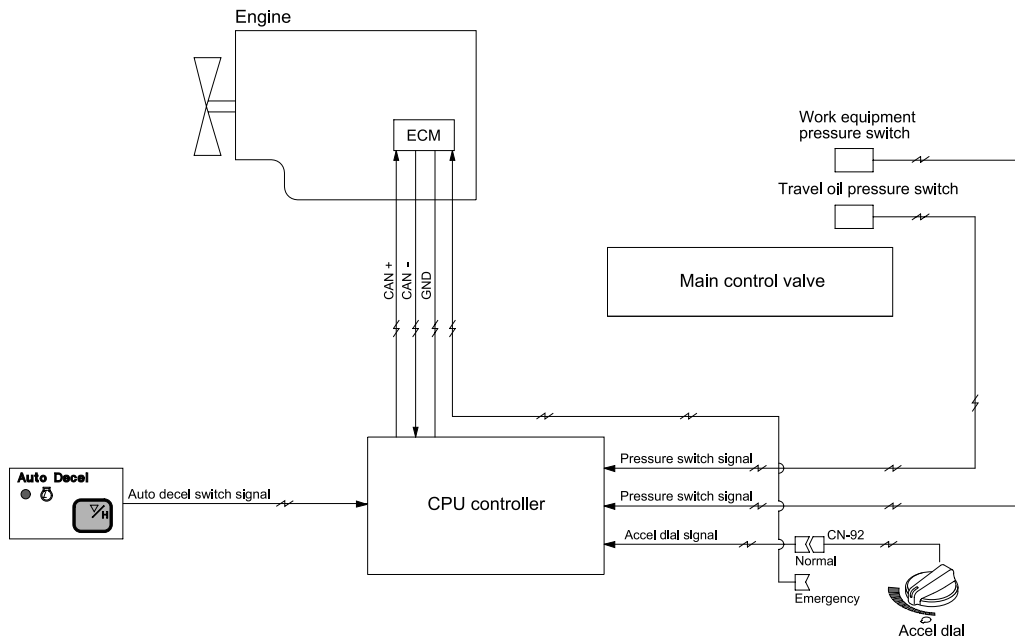

36075MS04

1. WHEN AUTO DECEL LAMP ON

If all the work equipment control levers including swing and travel levers are at neutral for at least 4 seconds, CPU controller transmits the throttle command to ECM to reduce the engine speed to 1100rpm. As the result of reducing the engine speed, fuel consumption and noise are effectively cut down during non-operation of the control levers.

When the Auto decel lamp is turned off by pressing the switch or any control lever is operated, the reduced engine speed rises up to the speed set before deceleration in a second.

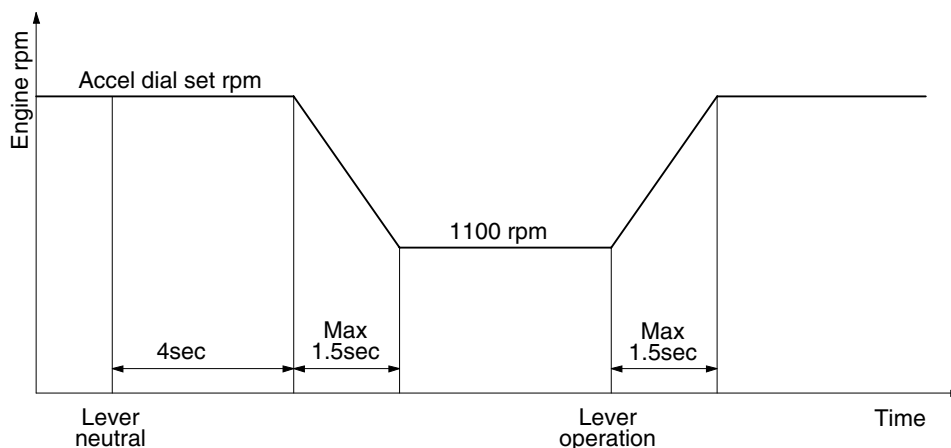

3607A5MS05

2. WHEN AUTO DECEL LAMP OFF

The engine speed can be set as desired using the engine speed switch, and even if the control levers are neutral, the engine speed is not reduced.

※ Auto decel function can be activated when accel dial position is over 4.