

GROUP 4 SINGLE OPERATION

1. BOOM RAISE CIRCUIT OPERATION

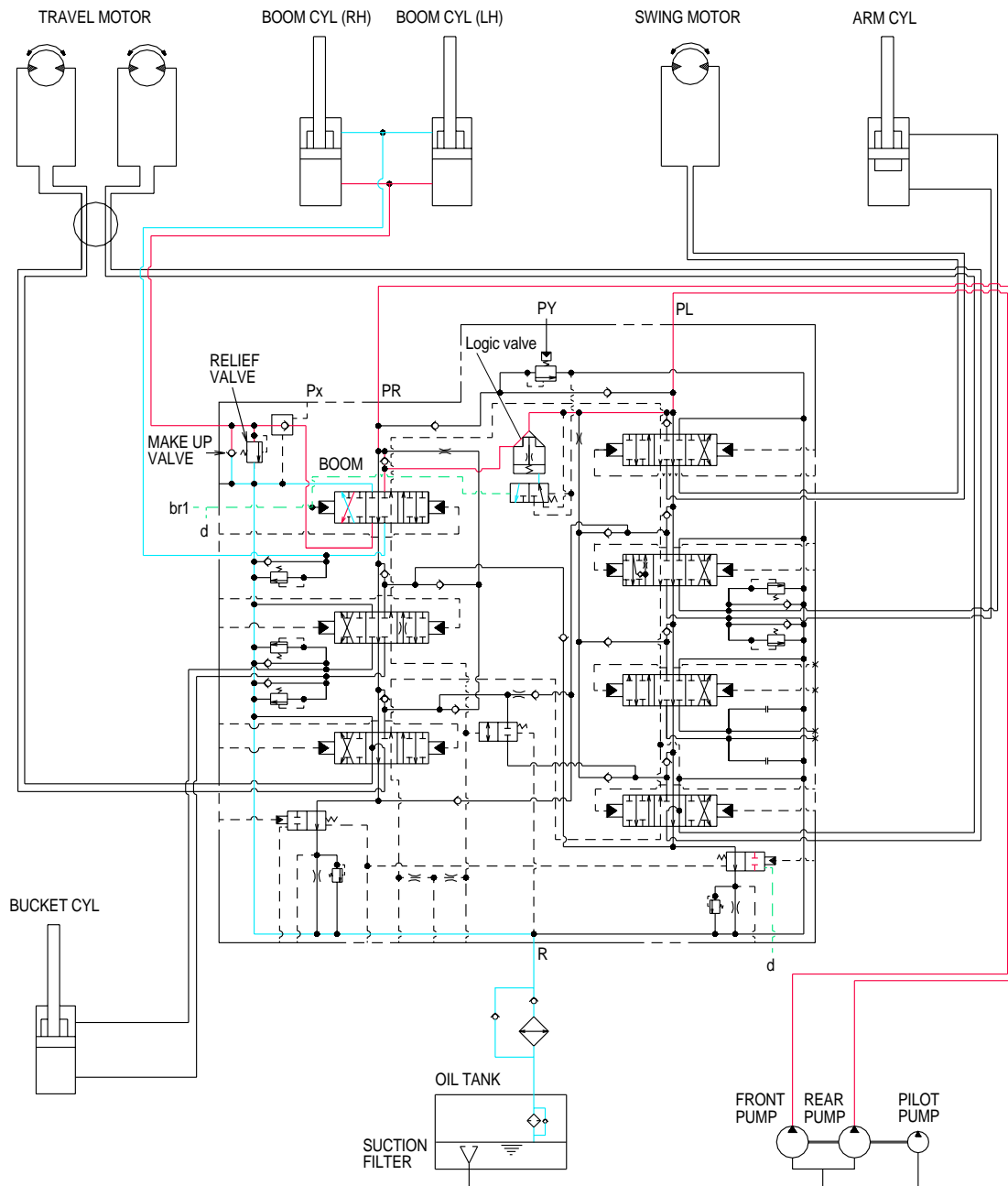

When the right control lever is pulled to boom raise position. Then the oil from pilot pump through the remote control valve to boom sections of the control valve.

Here, the spool positions are moved to the boom raise position, and the boom circuits are opened. The oil flows from rear pumps through boom section of the control valve and front pump via logic valve to the bottom end of the boom cylinders, and to raise the boom.

The return oil flow from the rod end of the cylinders are directed to the tank through the boom section of the control valve.

Cavitation and excessive pressure in the boom cylinder bottom end circuit is prevented by a overload relief and make up valve in the control valve.

2. BOOM DOWN CIRCUIT OPERATION

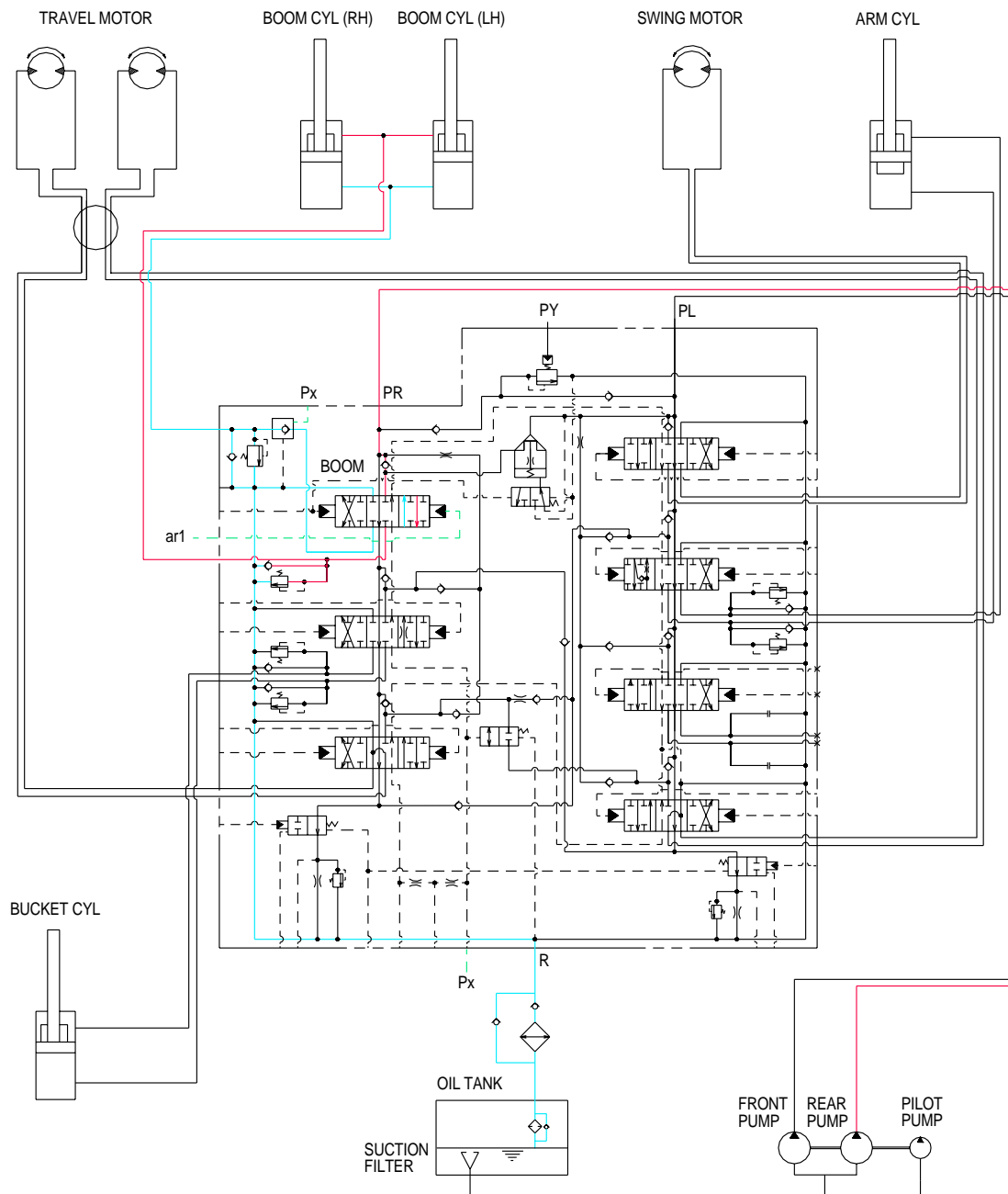

When the right control lever is pushed forward to boom lower position. Then the oil from pilot pump through the remote control valve to boom sections of the control valve. Here, the spool positions are moved to the boom lower position, and the boom lower circuit is opened.

Oil flows from rear pump through boom section of the control valve to the rod end of the boom cylinders, and to lower the boom.

The return oil flows from the bottom end of the cylinders to the tank through the boom section of the control valve.

Cavitation and excessive pressure in the boom cylinder rod end circuit is prevented by a overload relief and make up valve in the control valve.

3. ARM ROLL IN CIRCUIT OPERATION

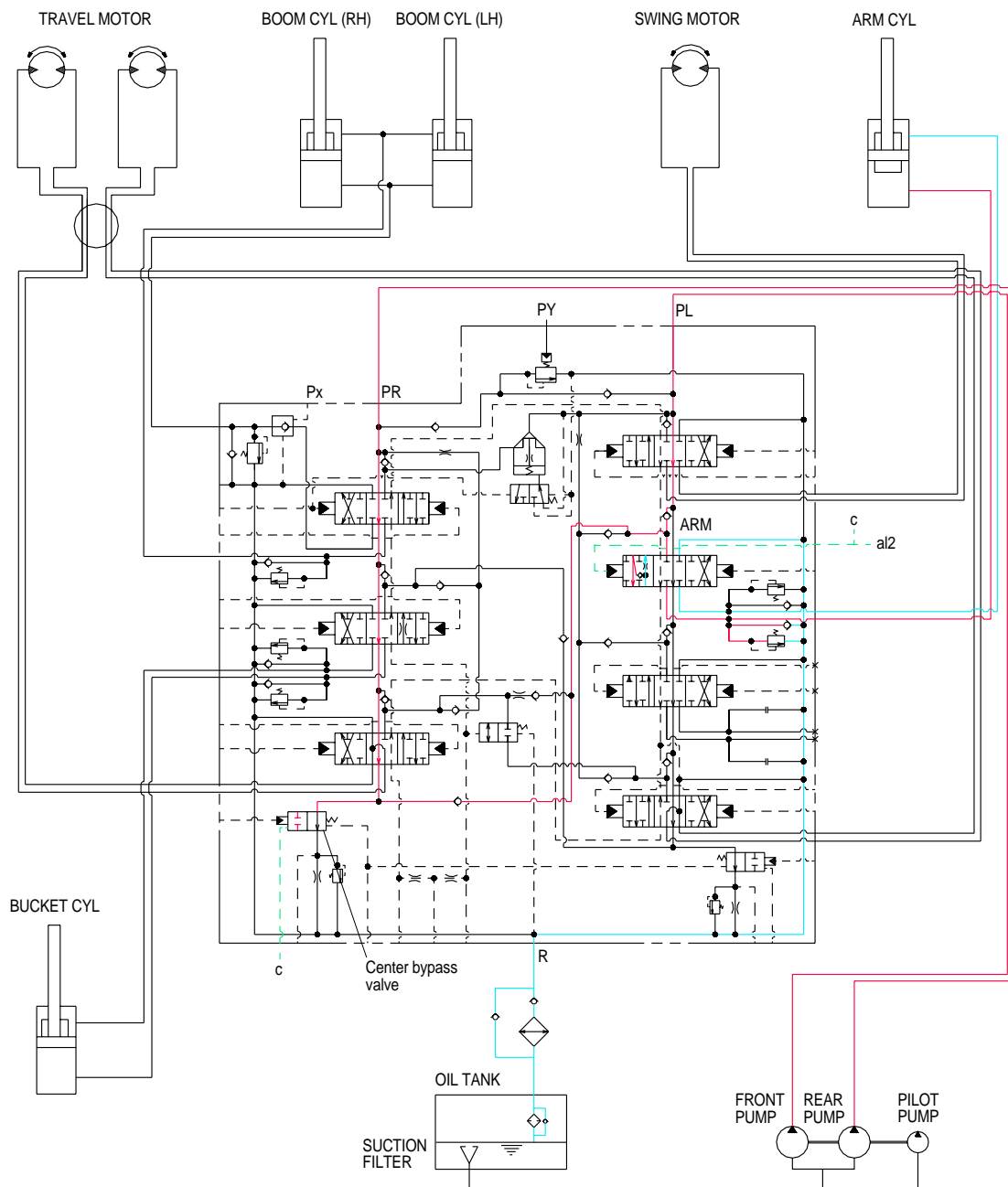

When the left control lever manually is placed in the arm roll in position.

Then the oil flows from pilot pump through the remote control valve to arm sections of the control valve. Here, the spool positions are moved to arm roll in position.

The center bypass valve is blocked by pilot pressure(c) and then the oil from rear pump is join to flow of the front pump via confluence passage.

The oil flows from both main pump through arm section of the control valve to the bottom end of the arm cylinder, and to roll in arm.

The return oil flows from the rod end of the cylinder through the arm section returned to the tank.

Then cavitation which will happen to the bottom of the arm cylinder is prevented by a make up valve, on other hand. The excess pressure is also prevented by an overload relief valve in the control valve.

4. ARM ROLL OUT CIRCUIT OPERATION

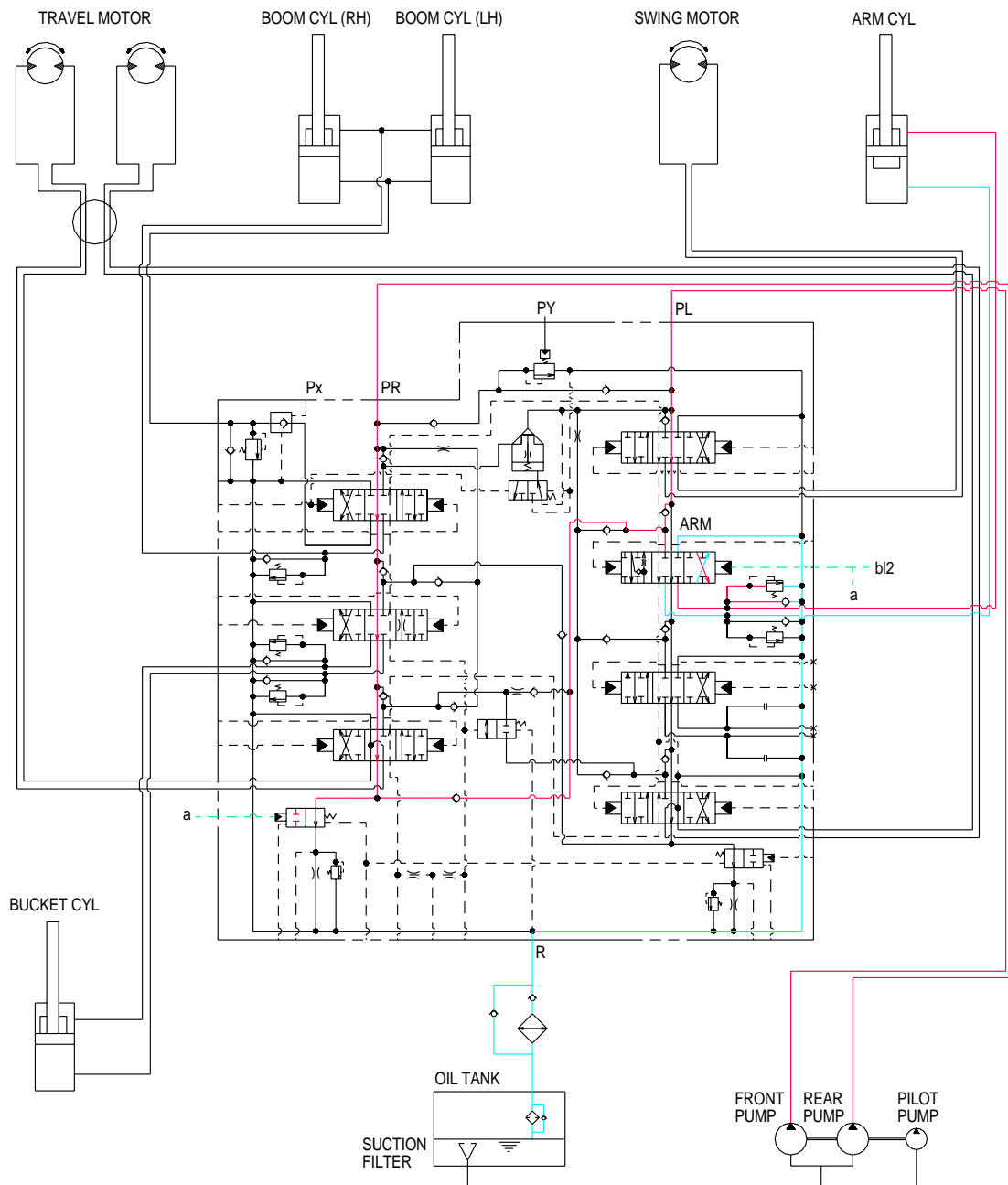

When the left control lever manually is placed in the arm roll out position.

Then the oil flows from pilot pump through the remote control valve to arm section of the control valve. Here, the spool positions are moved to arm roll out position.

The center bypass valve is blocked by pilot pressure(a) and then the oil from rear front pump is join to flow of the front pump via confluence passage.

The oil flows from both pump through arm section of control valve to the rod end of the bucket cylinder, and to roll out arm.

The return oil flows from the bottom end of the cylinder through the arm section returned to the tank.

The cavitation which will happen to the rod of the arm cylinder is prevented by a make up valve, on other hand. The excess pressure is also prevented by an overload relief valve in the control valve.

5. BUCKET ROLL IN CIRCUIT OPERATION

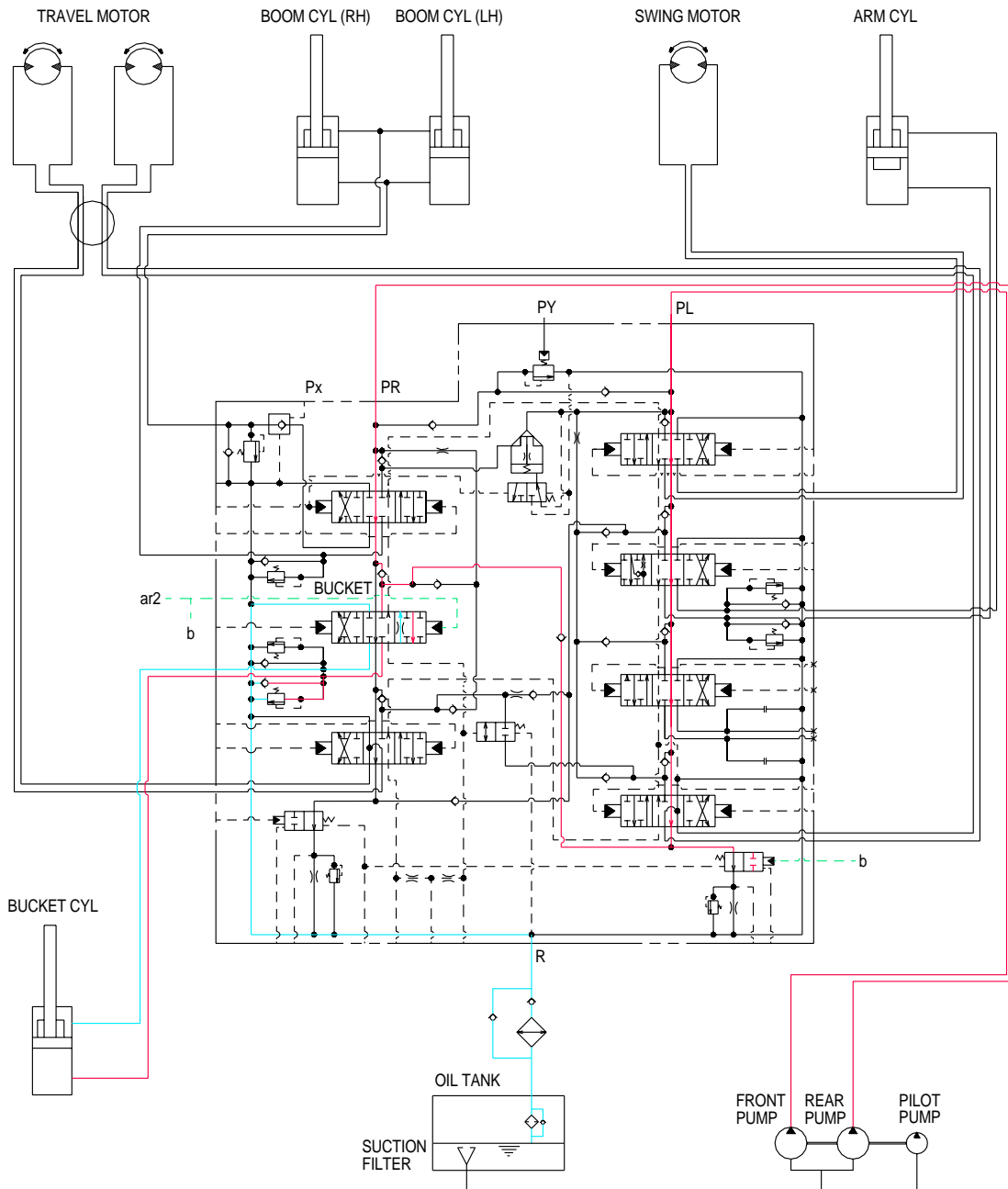

When the right control lever manually is placed in the bucket roll in position.

Then the oil flows from pilot pump through the remote control valve to bucket section of the control valve. Here, the spool positions are moved to bucket roll in position.

The center bypass valve is blocked by pilot pressure(b) and then the oil from front pump is join to flow of the rear pump via confluence passage.

The oil flows from both pump through bucket section of control valve to the rod end of the bucket cylinder, and to roll in bucket.

The return oil flows from the rod end of the cylinder through the bucket section returned to the tank.

The cavitation which will happen to the bottom of the bucket cylinder is prevented by a make up valve, on other hand. The excess pressure is also prevented by an overload relief valve in the control valve.

6. BUCKET ROLL OUT CIRCUIT OPERATION

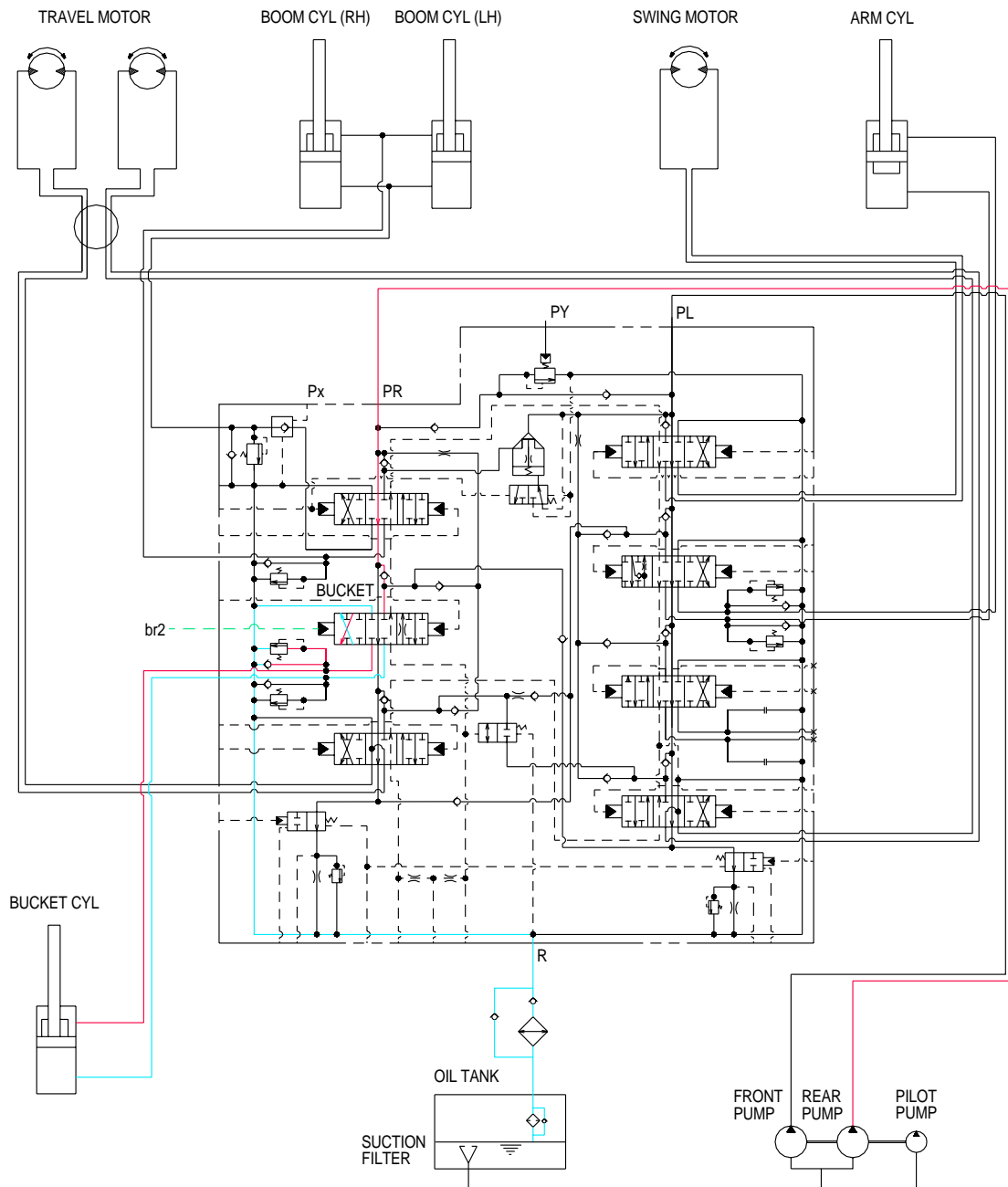

When the right control lever manually is placed in the bucket roll out position.

Then the oil flows from pilot pump through the remote control valve to bucket section of the control valve. Here, the spool positions are moved to bucket roll out position.

The oil flows from rear pump through bucket section of control valve to the rod end of the bucket cylinder, and to roll out bucket.

The return oil flows from the bottom end of the cylinder through the bucket section returned to the tank.

The cavitation which will happen to the rod of the bucket cylinder is prevented by a make up valve, on other hand. The excess pressure is also prevented by an overload relief valve in the control valve.

7. SWING CIRCUIT OPERATION

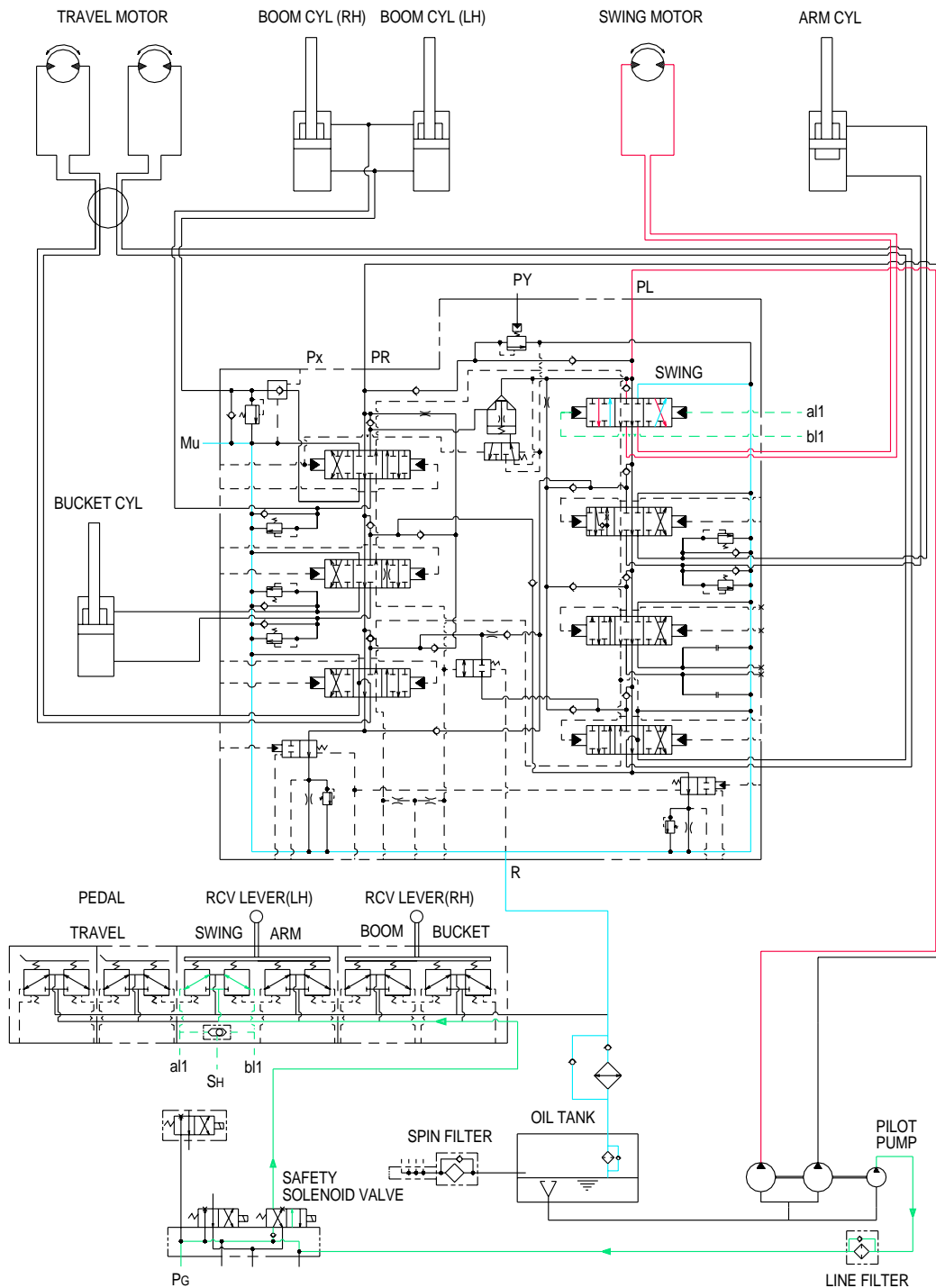

When the left control lever manually is placed in the swing position. Then the oil flows from pilot pump through the pilot valve to the swing section of the control valve. Here, the spool position is moved to right or left swing position.

The oil flows from front pump through swing section of the control valve to the swing motor and swings the superstructure.

The motor brake valve, make up valve and swing parking brake are provided in the swing motor.

SWING CIRCUIT OPERATION

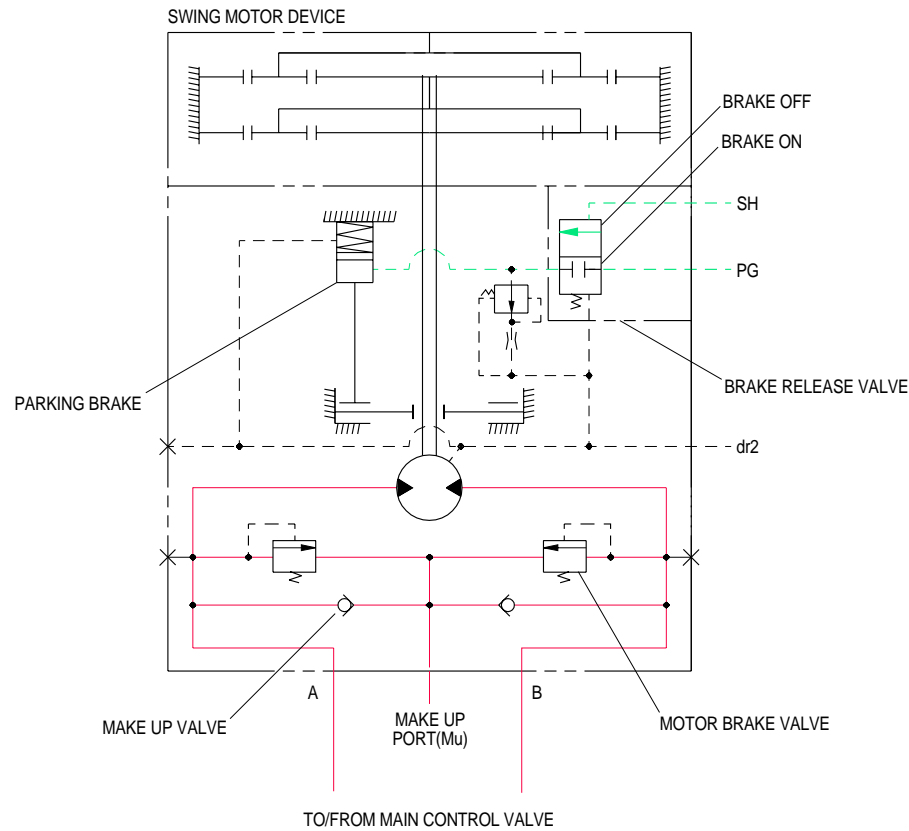

1) MOTOR BRAKE VALVE

Motor brake valve for the swing motor limits to cushion the starting and stopping pressure of swing operation.

2) MAKE UP VALVE

The make up valves prevent cavitation by supplying return oil to the vacuum side of the motor.

3) PARKING BRAKE

In case that the parking, of the machine at slope is required during operation, there is the danger of involuntary swing caused by the self weight of the machine. The brake is connected to prevent this involuntary swing.

PARKING BRAKE "OFF" OPERATION

The parking brake is released by the pilot pressure oil from the pilot pump.

When the left control lever placed in the swing position, the pilot pressure at the shuttle valve is transferred to the brake release valve and the brake release valve is change over. Then the pilot pressure lift the brake piston and release the parking brake.

PARKING BRAKE "ON" OPERATION

When the control lever placed in the neutral position, the pressure of the pilot oil passage down. Then the brake release valve returned to the neutral position and the oil is returned from the brake piston to the tank. And the brake is set to "ON".

TRAVEL CIRCUIT OPERATION

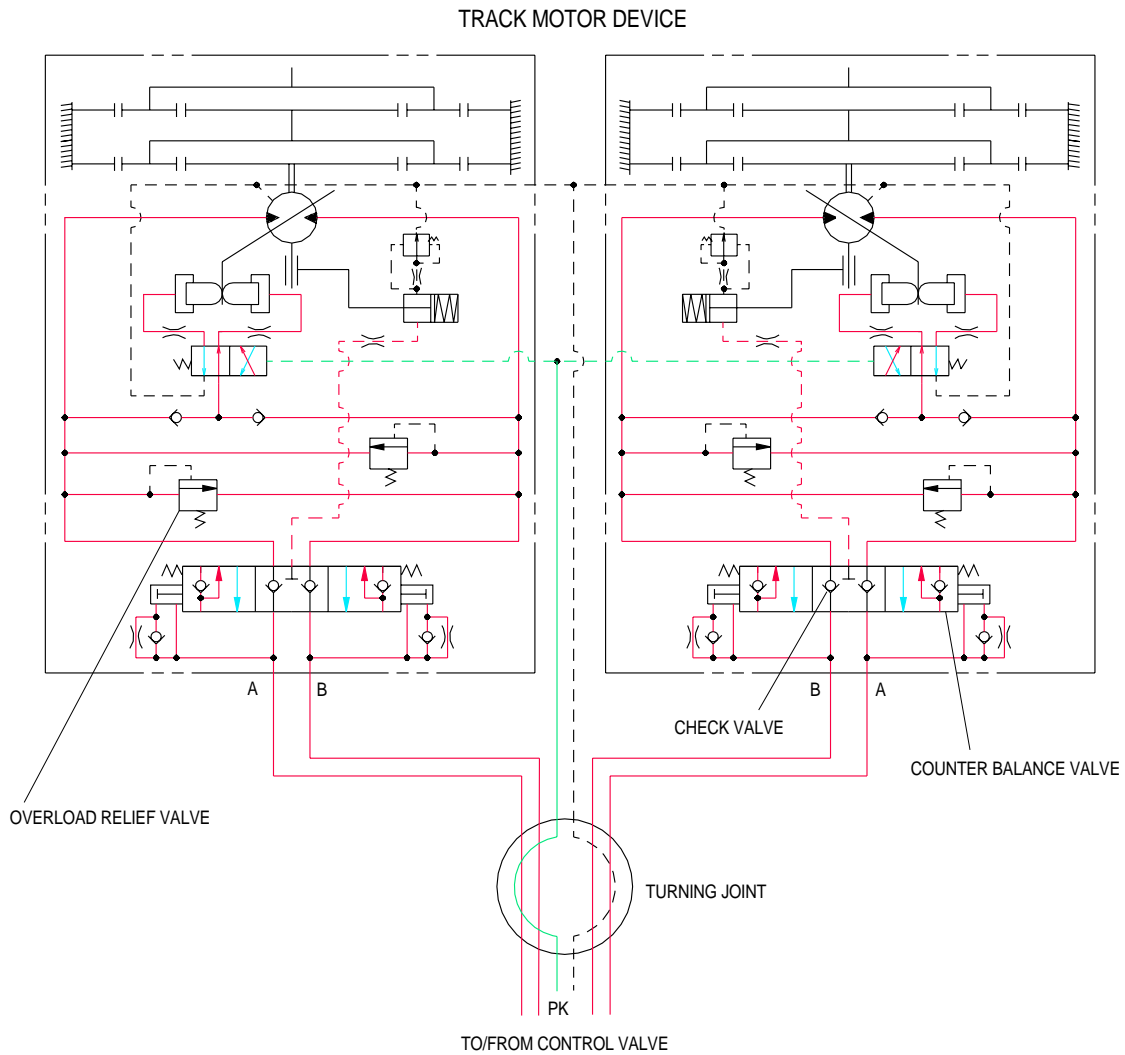

Brake valves are provided on travel motors to offer the following functions.

1) CHECK VALVE

Stopping the motor, this valve sucks the oil from lower pressure passage for preventing the negative pressure and the cavitation of the motor.

2) COUNTER BALANCE VALVE

When stopping the motor or slope descending, this valve to prevent the motor over run.

3) OVERLOAD RELIEF VALVE

Relief valve limit the circuit pressure below 350kg/cm^2 to prevent high pressure generated at a time of stopping the machine.