

GROUP 2 MODE SELECTION SYSTEM

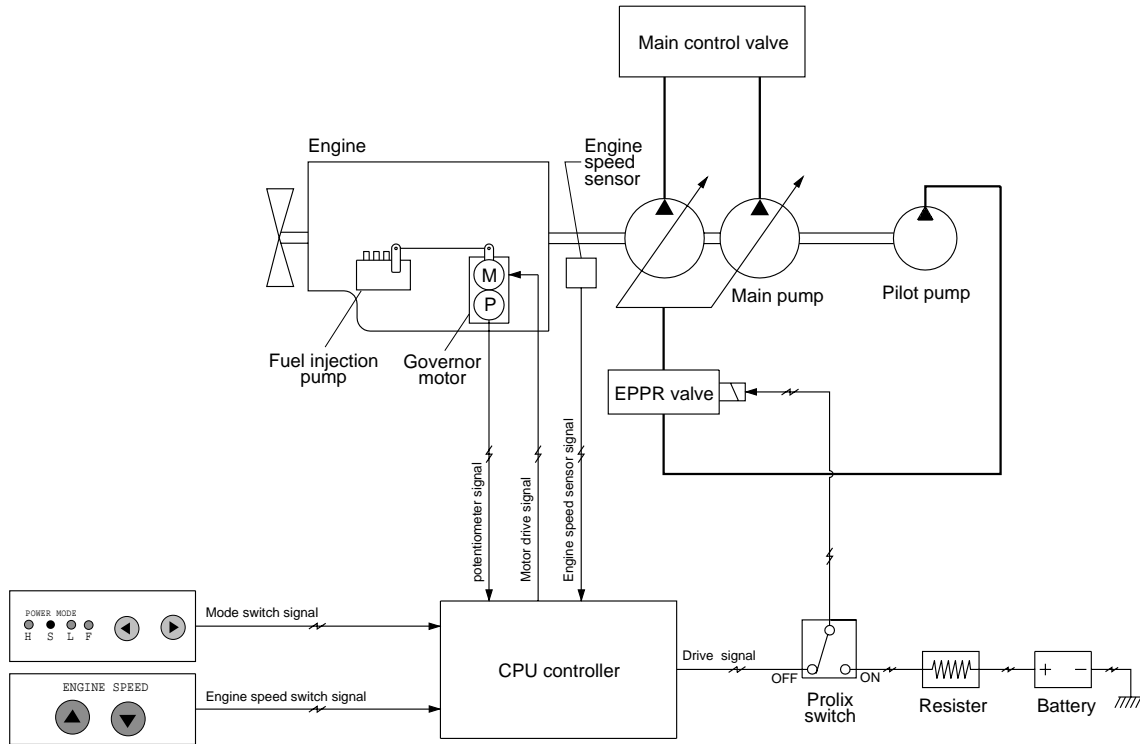

1. OUTLINE

Micro computer based electro-hydraulic pump and engine mutual control system (mode selection system) optimizes the engine and pump performance.

The combination of 4 power modes(H,S,L,F) makes it possible to use the engine and pump power more effectively corresponding to the work conditions from a heavy and great power requesting work to a light and precise work.

Item	Mode	Application	Engine rpm	
			Idle rpm	Rated rpm
POWER MODE	H	Heavy duty operation	2150+50	2000
	S	General operation	2150+50	2000
	L	Light duty operation	1950+50	1800
	F	Finishing operation	1650+50	1500
TRAVEL MODE	LO	Low speed travelling	—	—
	Hi	High speed travelling	—	—
KEY STARTING	—	Key switch start position	800 ± 100	—
AUTO DECEL MODE	—	Engine deceleration	1200 ± 100	—

When engine start, S mode, Auto Decel and Travel Lo(Turtle) mode are selected automatically.

2. PUMP CONTROL BY ENGINE SPEED SENSING

If any engine speed drops under the reference rpm of each mode set caused by the pump load are detected by the engine speed sensor, CPU controller sends calculated current signal to EPPR(Electro Proportional Pressure Reducing) valve to match engine torque with pump torque optimally by controlling the pump discharge volume.

- **H** : Heavy duty operation mode
- **S** : General operation mode
- **L** : Lifting operation mode
- **F** : Finishing operation mode

• Engine Torque

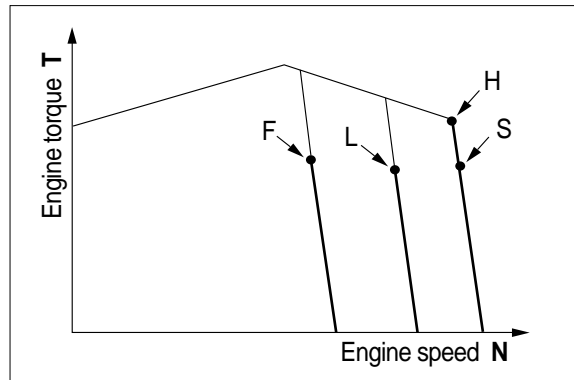

• Engine horsepower

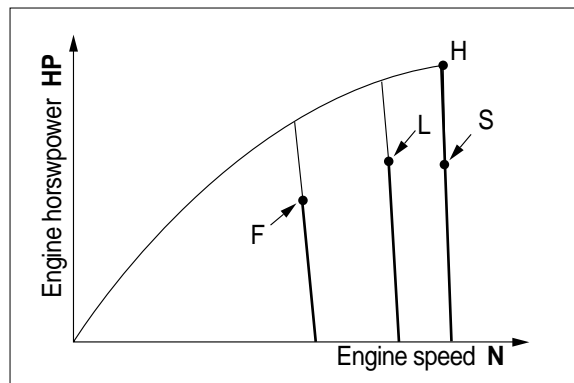

• Main pump delivery

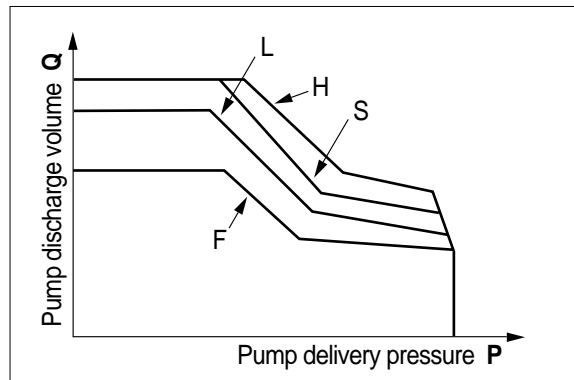

3. MAXIMUM POWER OF H MODE

- 1) When **H** mode is selected in the cluster, CPU controller moves the engine governor motor to set the throttle lever to the full position and sends initial current signal to the EPPR valve to set the pump absorption torque high. So, it is possible to maximize the work performance by using 100% of the engine power at this mode.
- 2) If the pump load becomes too high and the engine speed drops, the CPU controller reduces the pump discharge amount and momentarily resets the engine speed to the rated point through engine speed sensing.

• Engine Torque

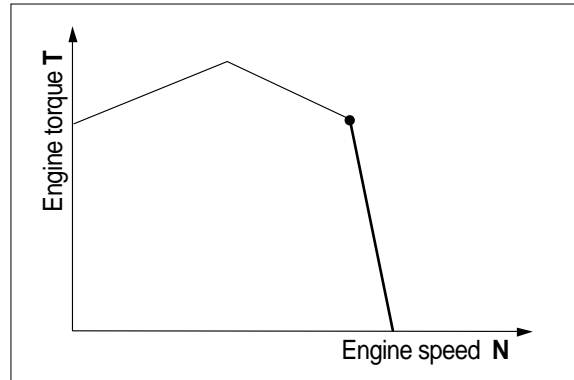

• Engine horsepower

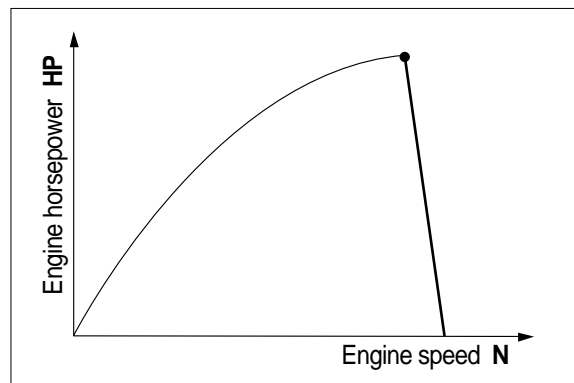

• Main pump delivery

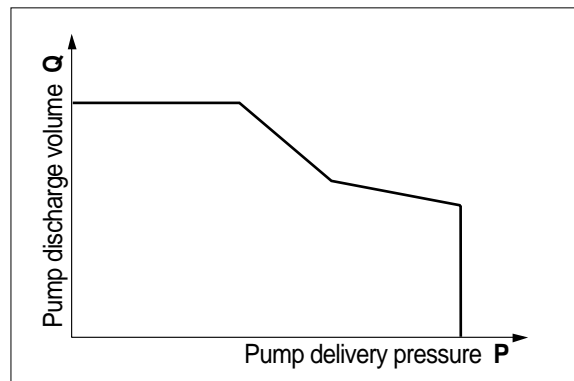

4. GENERAL STANDARD POWER OF S MODE

- 1) When **S** mode is selected in the cluster, CPU controller moves the engine governor motor to set the throttle lever to the full position and sends power shift current to EPPR valve which reduces the pump discharge. So the pump absorption horsepower is reduced by 15%.
- 2) Engine speed sensing at the matching point is the same as for **H** mode.

• Engine Torque

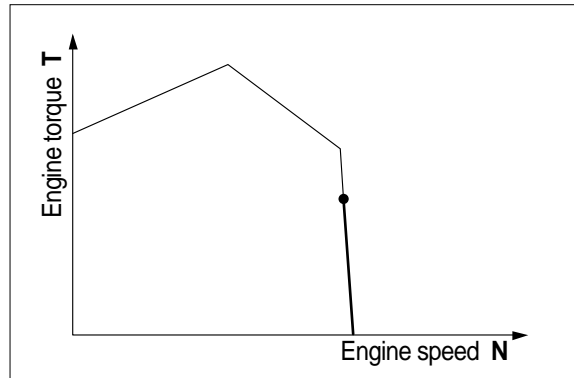

• Engine horsepower

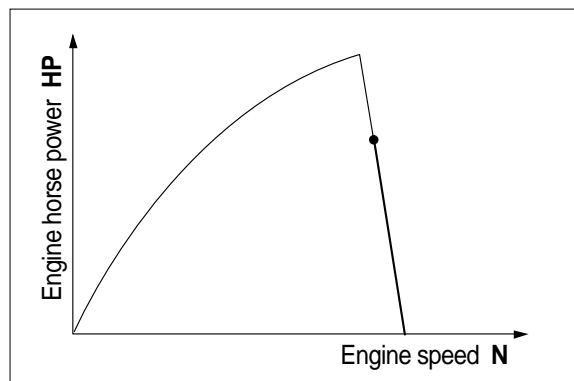

• Main pump delivery

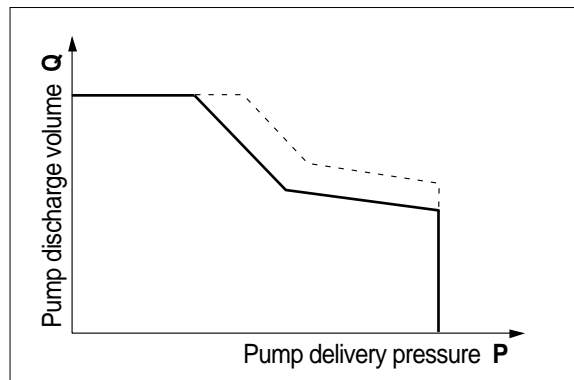

5. ENERGY SAVING AND LIGHT POWER OF L MODE

- 1) When **L** mode is selected in the cluster, CPU controller moves the engine governor motor to set the throttle lever to the partial position and it sends large amount of power shift current to EPPR valve, which reduces the pump absorption horsepower 30%. So, at the this mode it is useful for light work and energy saving.
- 2) Engine speed and pump absorption horsepower are different, but the engine sensing at the matching point is the same as for **H** mode.

• Engine Torque

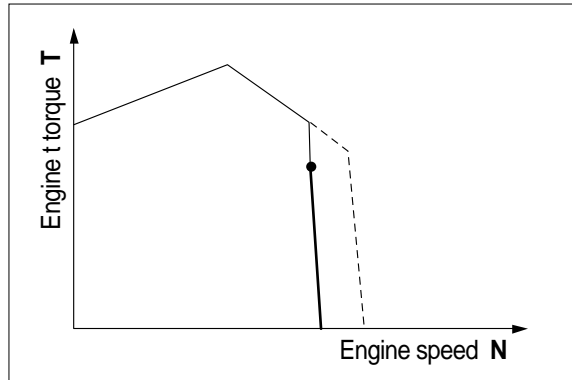

• Engine horsepower

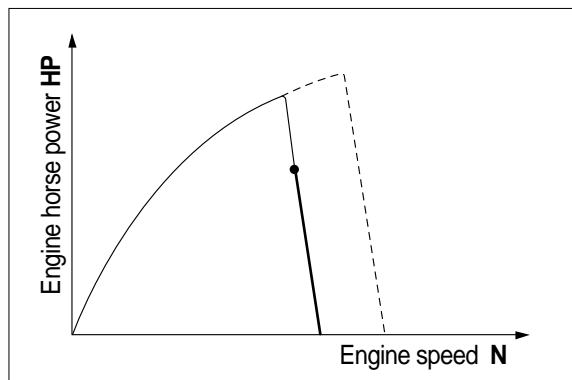

• Main pump delivery

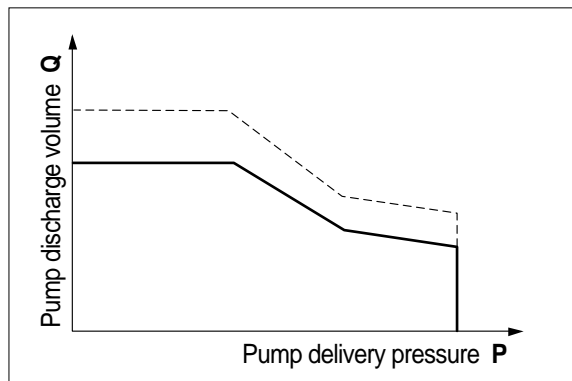

6. FINISHING WORK OF F MODE

- 1) When **F** mode is selected in the cluster, CPU controller moves the engine governor motor to set the throttle lever to the partial position and it sends of power shift current to EPPR valve to reduces the pump absorption horsepower to the least amount as much as 50% of full horsepower. So, at this mode it is useful light work, especially for finishing work.
- 2) Engine speed and pump absorption horsepower are set at highly efficient area for engine fuel consumption, so the fuel reduction effect is extremely large.

• Engine Torque

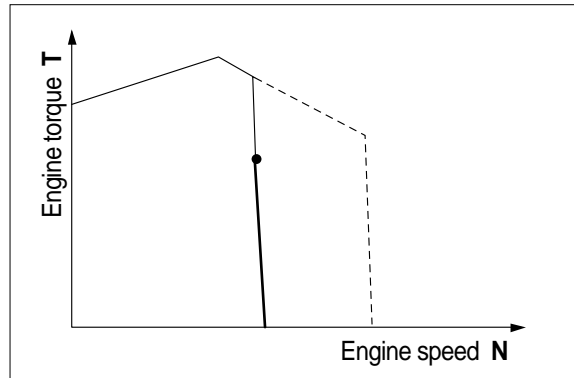



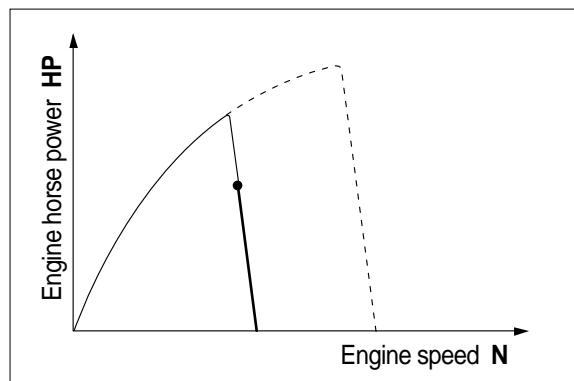

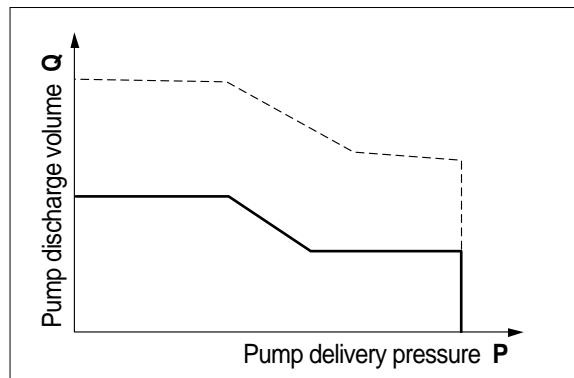

• Engine horsepower

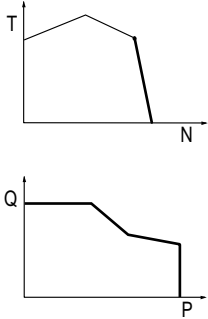
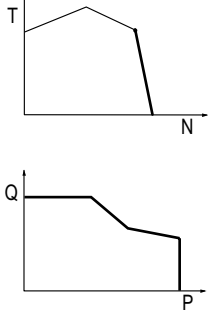
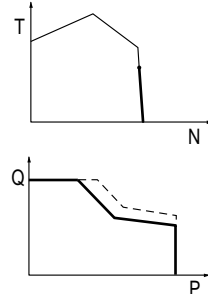

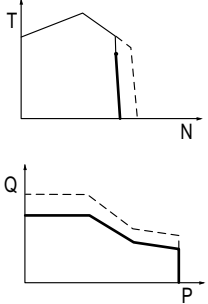
• Main pump delivery

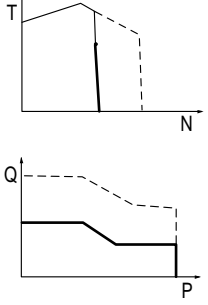

Mode	Power boost switch OFF		Power boost switch ON		Other functions	
	Power set	Level of achievement	Power set	Level of achievement	Auto decel	Overheat prevention
H	250HP/ 2000rpm	<ul style="list-style-type: none"> Full power used by engine speed sensing. 	250HP/ 2000rpm	<ul style="list-style-type: none"> Full power used by engine speed sensing. Power increased by 2-stage relief solenoid valve. 	ON / OFF	ON
S	213HP/ 2000rpm	<ul style="list-style-type: none"> Power shift by eppr valve. 		250HP/ 2000rpm		ON / OFF
L	175HP/ 1800rpm	<ul style="list-style-type: none"> Fuel consumption improved by partial use of engine power. 				ON / OFF
F	125HP/ 1500rpm	<ul style="list-style-type: none"> Increase of fine control range. High improvement in fuel consumption by lowering engine speed. 			ON / OFF	ON