

**GROUP 2 ELECTRICAL CIRCUIT**

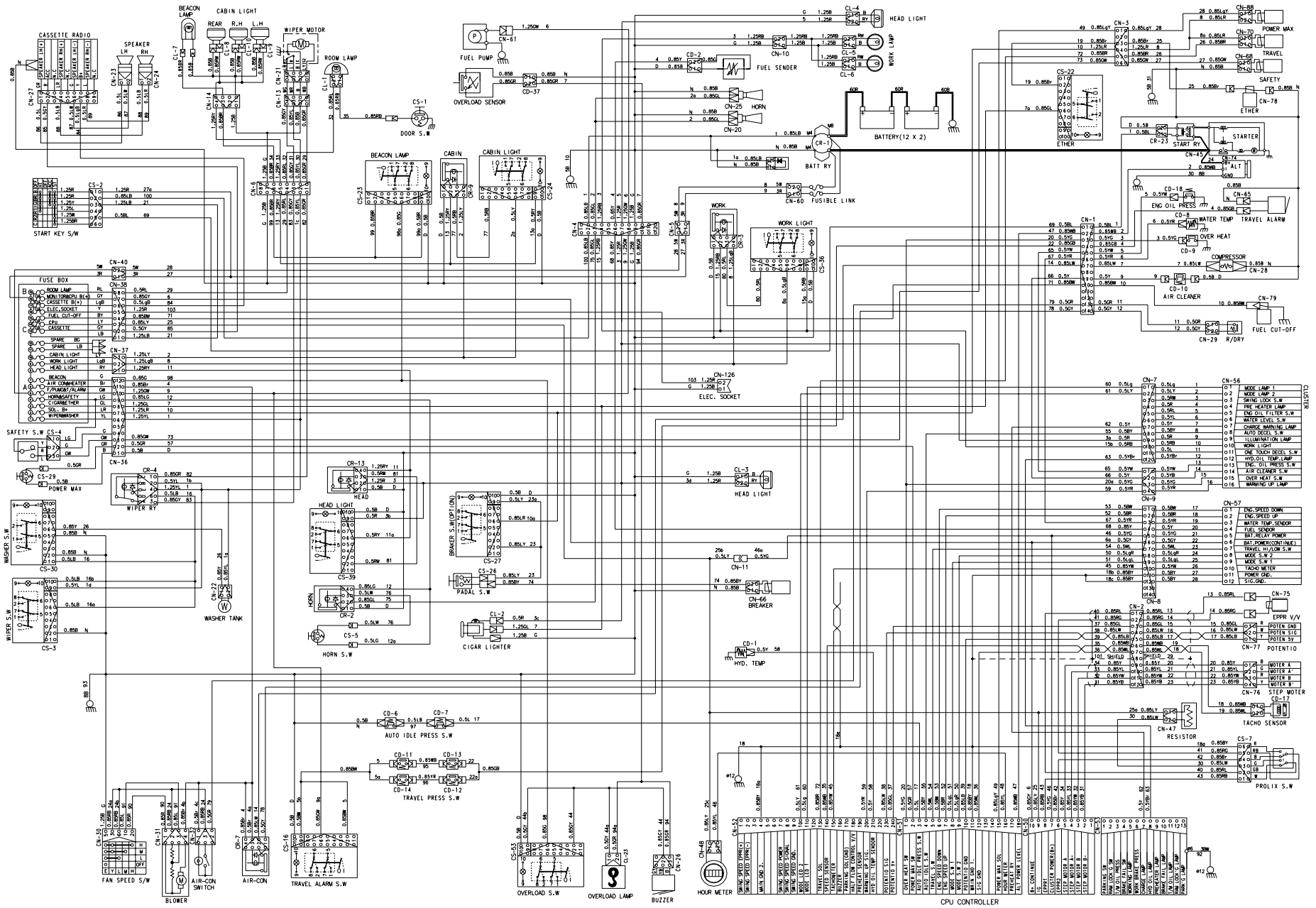

## 1. POWER CIRCUIT

The negative terminal of battery is grounded to the machine chassis.

When the start key switch is in the OFF position, the current flows from the positive battery terminal as shown here.

### 1) OPERATING FLOW

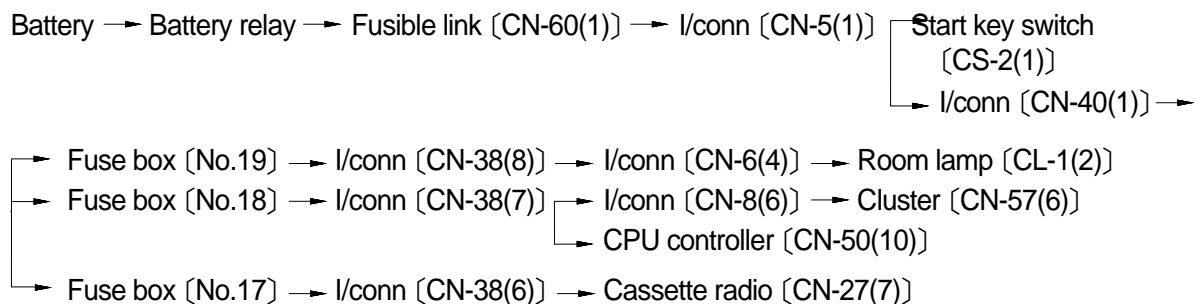

### 2) CHECK POINT

Engine	Key switch	Check point	Voltage
OFF	OFF	① - GND (Battery 1 EA) ② - GND (Battery 2 EA) ③ - GND (Battery 2 EA) ④ - GND (Fusible link )	10 ~ 12.5V 20 ~ 25V 20 ~ 25V 20 ~ 25V

※ GND : Ground

# POWER CIRCUIT

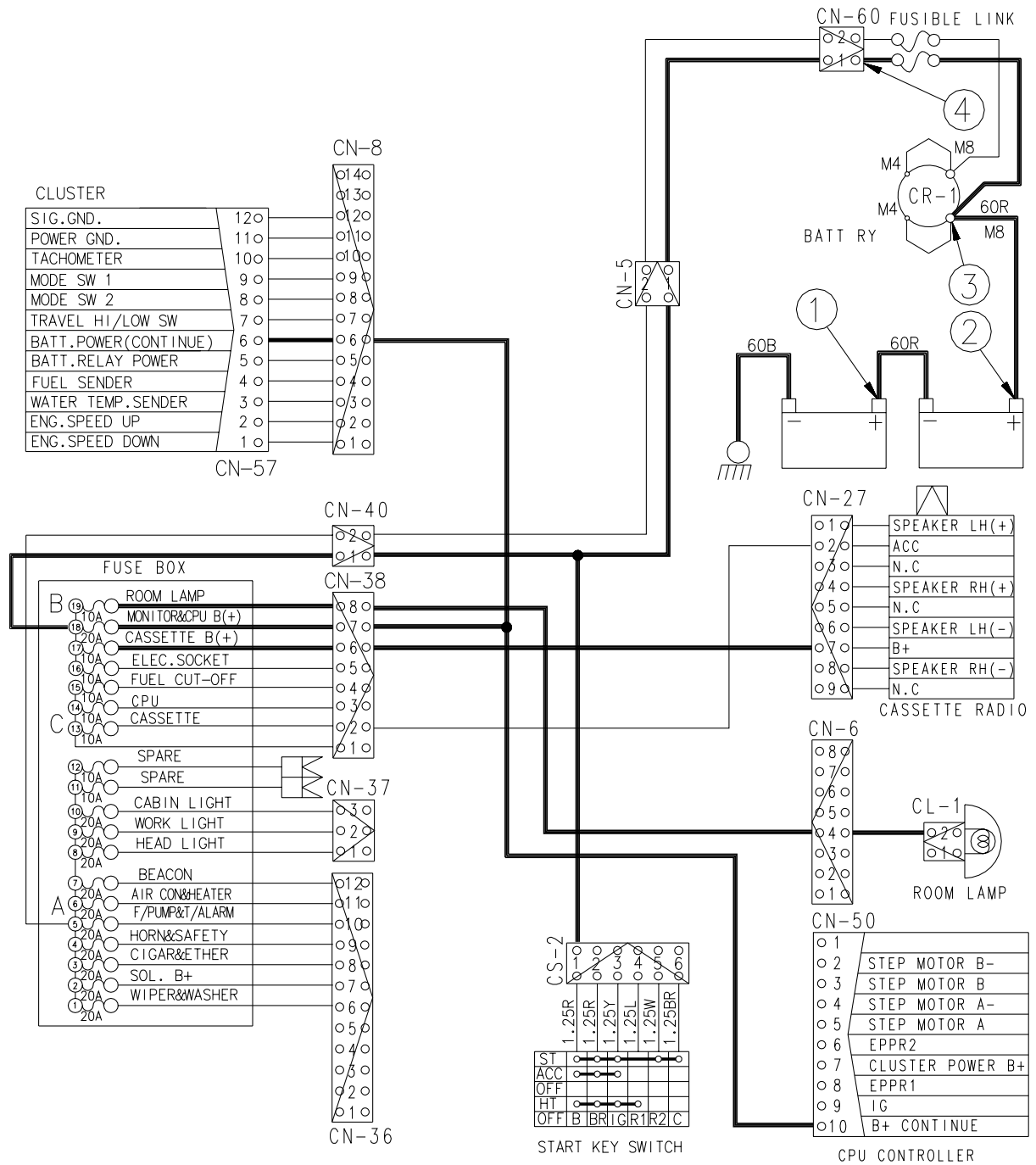

## 2. STARTING CIRCUIT

### 1) OPERATING FLOW

Battery(+) terminal → Battery relay(M8, B<sup>+</sup> terminal) → Fusible link [CN-60(1)]  
 → I/conn [CN-5(1)] → Start switch [CS-2(1)]

※ When start key switch is in ON position

→ Start key switch ON [CS-2(2)] → I/conn [CN-4(2)] → Battery relay [M4 terminal]  
 → Battery relay operating(All power is supplied with the electric component)  
 → Start key switch ON [CS-2(3)] → I/conn [CN-38(1)]  
 → Fuse box(No. 13)  
 → Fuse box(No. 14)  
 → Fuse box(No. 15) → I/conn [CN-38(4)] → I/conn [CN-1(10)]  
 → Fuel cut-off [CN-79]

※ When start key switch is in START position

Start key switch START [CS-2(5)] → I/conn [CN-1(1)] → Start relay [CR-23(1)]

### 2) CHECK POINT

Engine	Key switch	Check point	Voltage
Operating	Start	① - GND (Battery) ② - GND (Start key) ③ - GND (Battery relay M4) ④ - GND (Start B) ⑤ - GND (Start S) ⑥ - GND (Start relay) ⑦ - GND (Battery relay M8)	20 ~ 25V

※ GND : Ground

# STARTING CIRCUIT

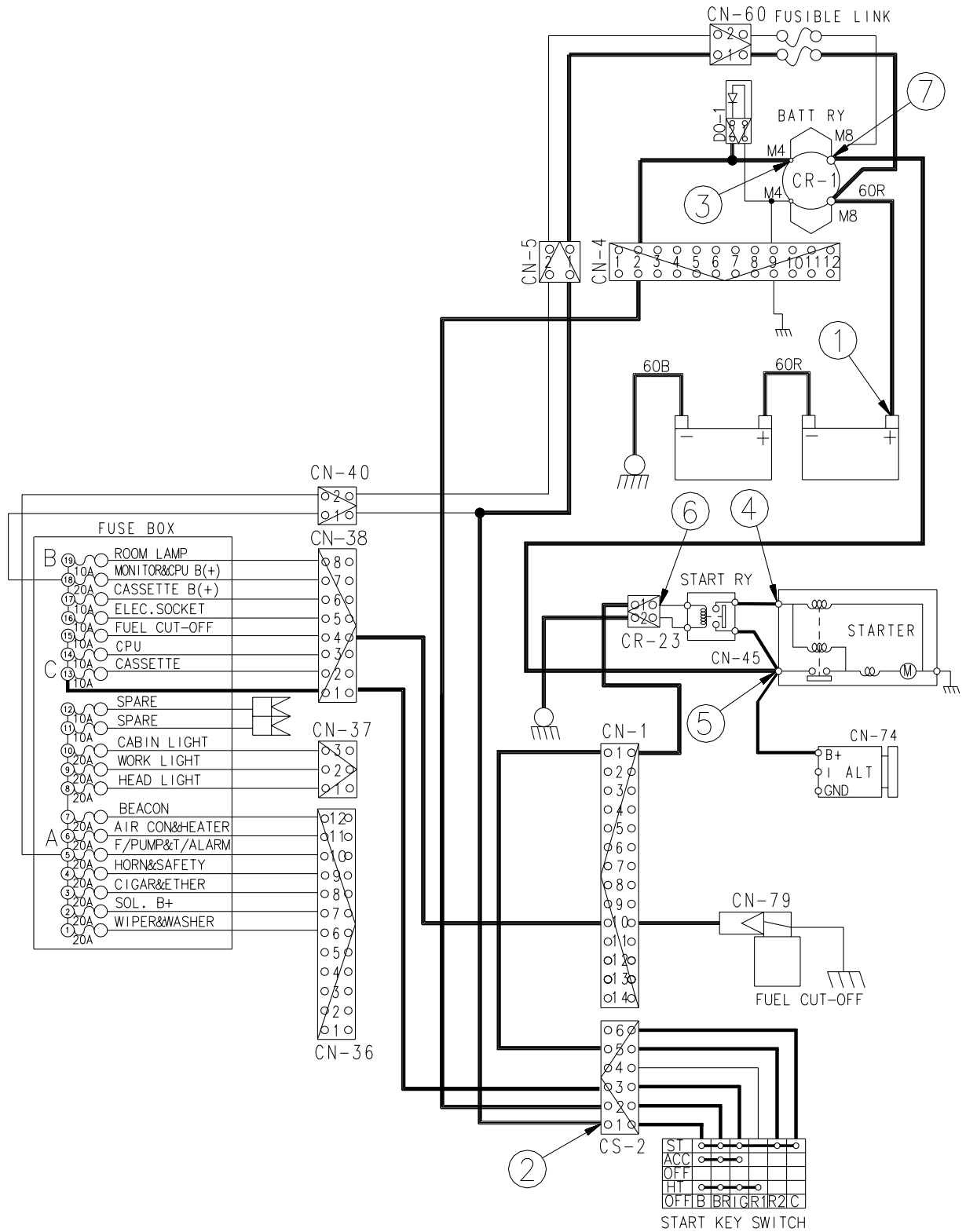

### 3. CHARGING CIRCUIT

When the starter is activated and the engine is started, the operator releases the key switch to the ON position.

Charging current generated by operating alternator flows into the battery through the battery relay(CR-1).

The current also flows from alternator to each electrical component and controller through the fuse box.

#### 1) OPERATING FLOW

##### (1) Warning flow

Alternator “I” terminal → I/conn [CN-1(2)] → CPU Alternator power level [CN-51(18)],  
Charging lamp [CN-53(7)] → I/conn [CN-7(7)] → Cluster charging warning lamp [CN-56(7)]

##### (2) Charging flow

Alternator B+ terminal → Battery relay (M8) → Battery(+) terminal  
→ Fusible link [CN-60(2)] →  
I/conn [CN-5(2)] → I/conn [CN-40(2)] → Fuse Box

#### 2) CHECK POINT

Engine	Key switch	Check point	Voltage
ON	ON	① - GND (Battery voltage) ② - GND (Battery relay) ③ - GND (Alternator B terminal) ④ - GND (Alternator I terminal) ⑤ - GND CPU ⑥ - GND CPU ⑦ - GND Cluster	20 ~ 27V

※ GND : Ground

# CHARGING CIRCUIT

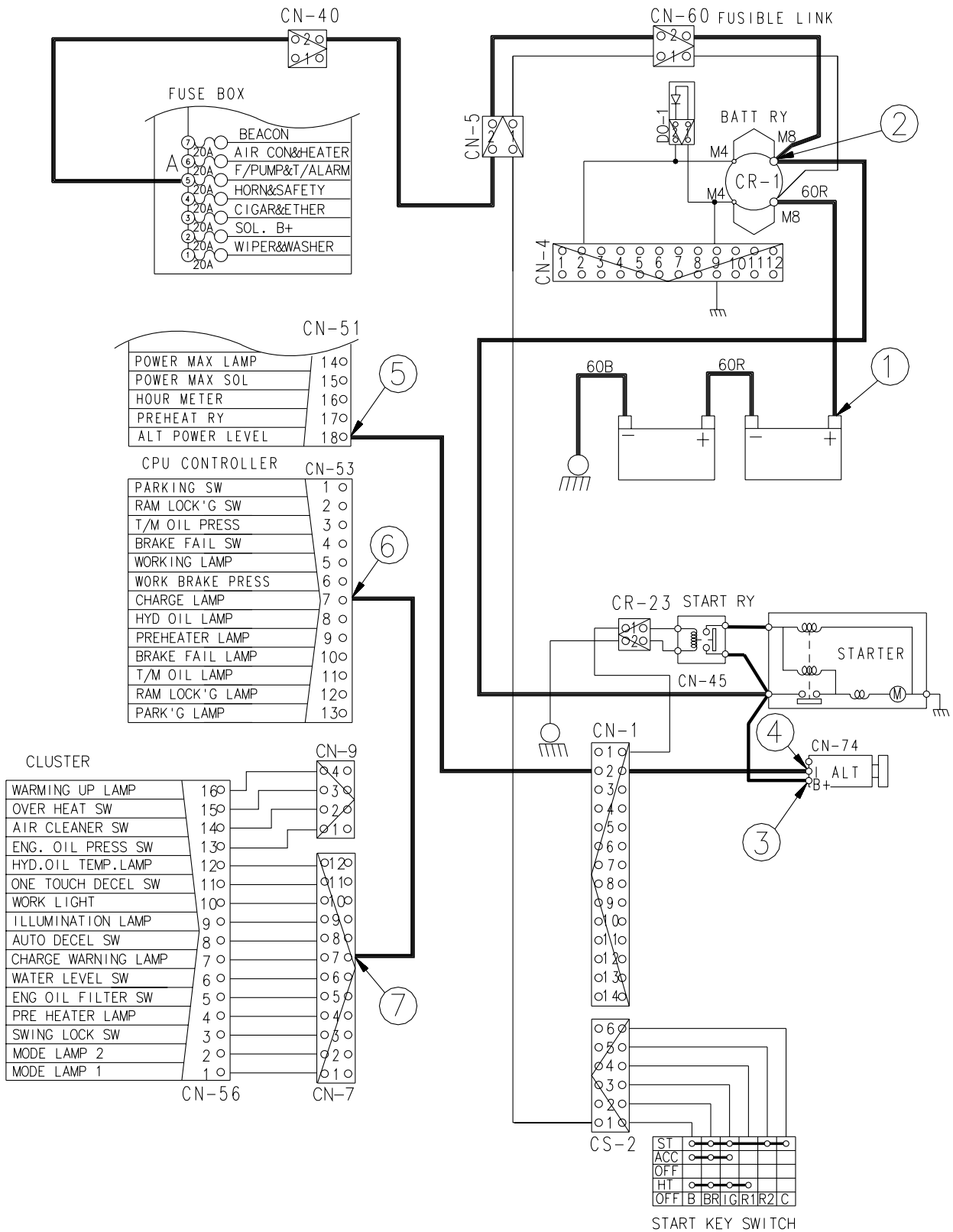

## 4. HEAD LIGHT CIRCUIT

### 1) OPERATING FLOW

Fuse box (No.8) → I/conn [CN-37(1)] → Head light switch [CS-39(6)]  
 → Head light relay [CR-13(4)]

※ When light switch ON

Head light switch ON [CS-39(2)] → Head light relay [CR-13(3) → (1)] → Ground  
 → Head light relay [CR-13(4) → (2)] →

→ Head light ON [CL-3(2)]  
 → I/conn [CN-4(7)] → Head light ON [CL-4(2)]  
 → I/conn [CN-7(9)] → Cluster illumination lamp [CN-56(9)]

### 2) CHECK POINT

Engine	Key switch	Check point	Voltage
STOP	ON	① - GND (Fuse box) ② - GND (Switch power input) ③ - GND (Switch power output) ④ - GND (Relay input) ⑤ - GND (Relay coil) ⑥ - GND (Relay output) ⑦ - GND (Head light)	20 ~ 25V

※ GND : Ground



# HEAD LIGHT CIRCUIT

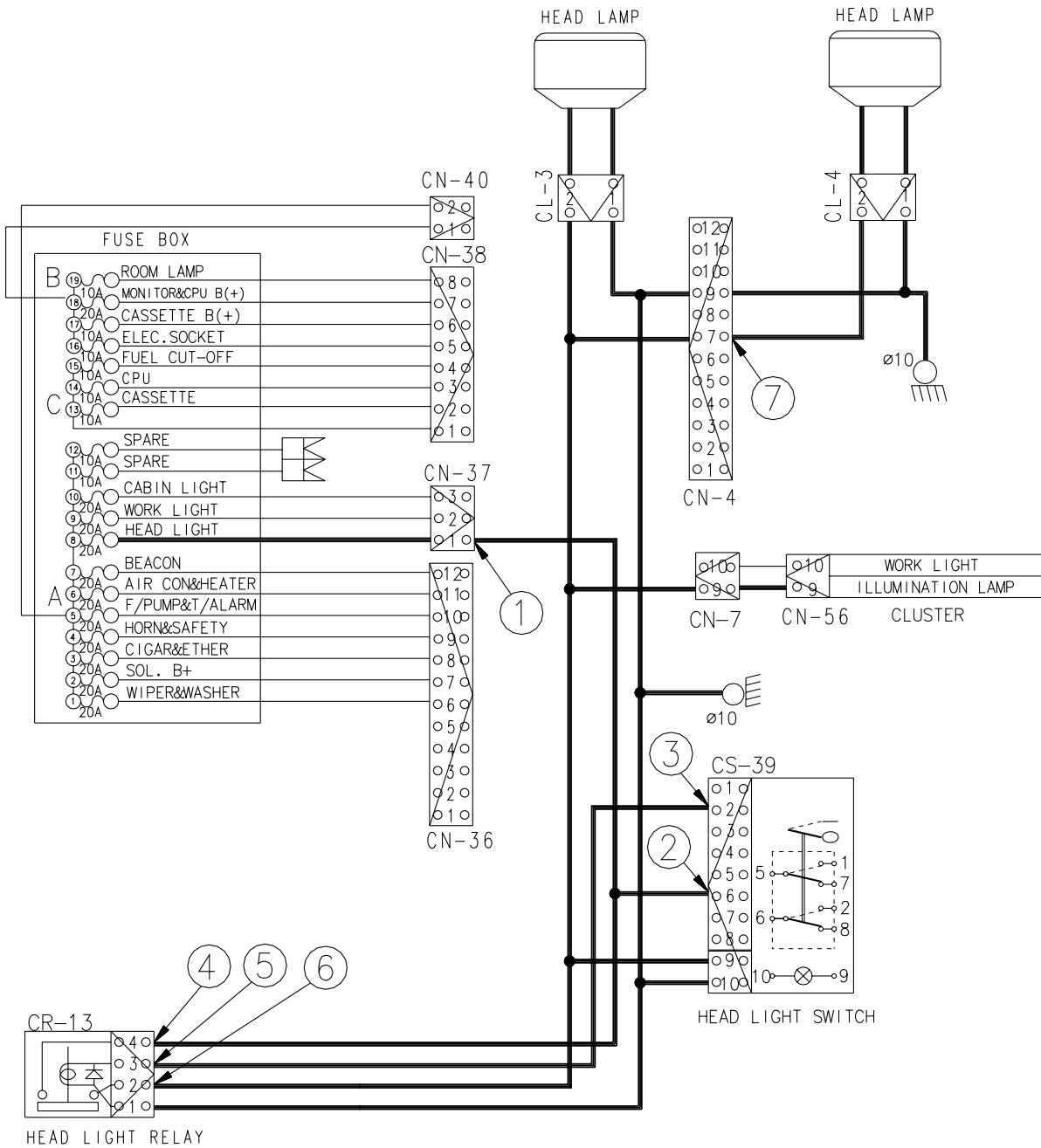

## 5. WORK LIGHT CIRCUIT

### 1) OPERATING FLOW

Fuse box (No.9) → I/conn [CN-37(2)] → Work light switch [CS-36(6)]  
 → Work light switch [CR-3(4)]

※ When light switch ON

Work light switch ON [CS-36(2)] → Work light relay [CR-3(3) → (1)] → Ground  
 → Work light relay [CR-3(4) → (2)] →

I/conn [CN-7(10)] → Cluster work light ON [CN-56(10)]

I/conn [CN-4(4)] → I/conn [CN-10(2)] → Work light ON [CL-6(2), CL-5(2)]

### 2) CHECK POINT

Engine	Key switch	Check point	Voltage
STOP	ON	① - GND (Fuse box) ② - GND (Switch power input) ③ - GND (Switch power output) ④ - GND (Relay input) ⑤ - GND (Relay coil) ⑥ - GND (Relay output) ⑦ - GND (Work light)	20 ~ 25V

※ GND : Ground

# WORK LIGHT CIRCUIT

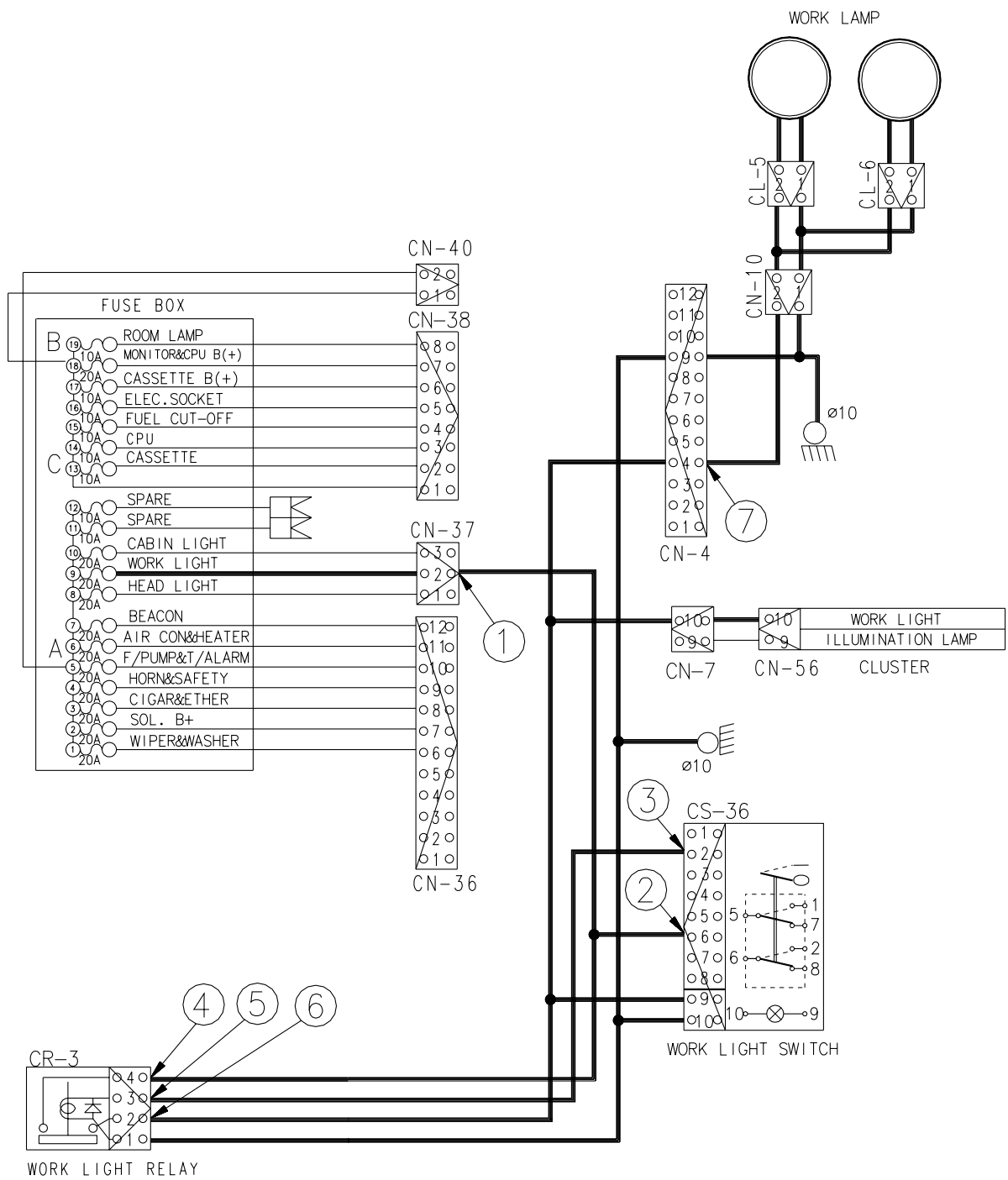

## 6. CAB LIGHT CIRCUIT

### 1) OPERATING FLOW

Fuse box (No.10) → I/conn [CN-37(3)] → Cab light switch [CS-24(6)]  
 → Cab light relay [CR-9(4)]

※ When light switch ON

Cab light switch ON [CS-24(2)] → Cab light relay [CR-9(3) → (1)] → Ground  
 → Cab light relay [CR-9(4) → (2)] →  
 → I/conn [CN-6(5)] → I/conn [CN-14(4)] → Cab light ON [CL-8(rear), CL-10(RH), CL-9(LH)]

### 2) CHECK POINT

Engine	Key switch	Check point	Voltage
STOP	ON	① - GND (Fuse box) ② - GND (Switch power input) ③ - GND (Switch power output) ④ - GND (Relay input) ⑤ - GND (Relay coil) ⑥ - GND (Relay output) ⑦ - GND (Cab light)	20 ~ 25V

※ GND : Ground

# CAB LIGHT CIRCUIT

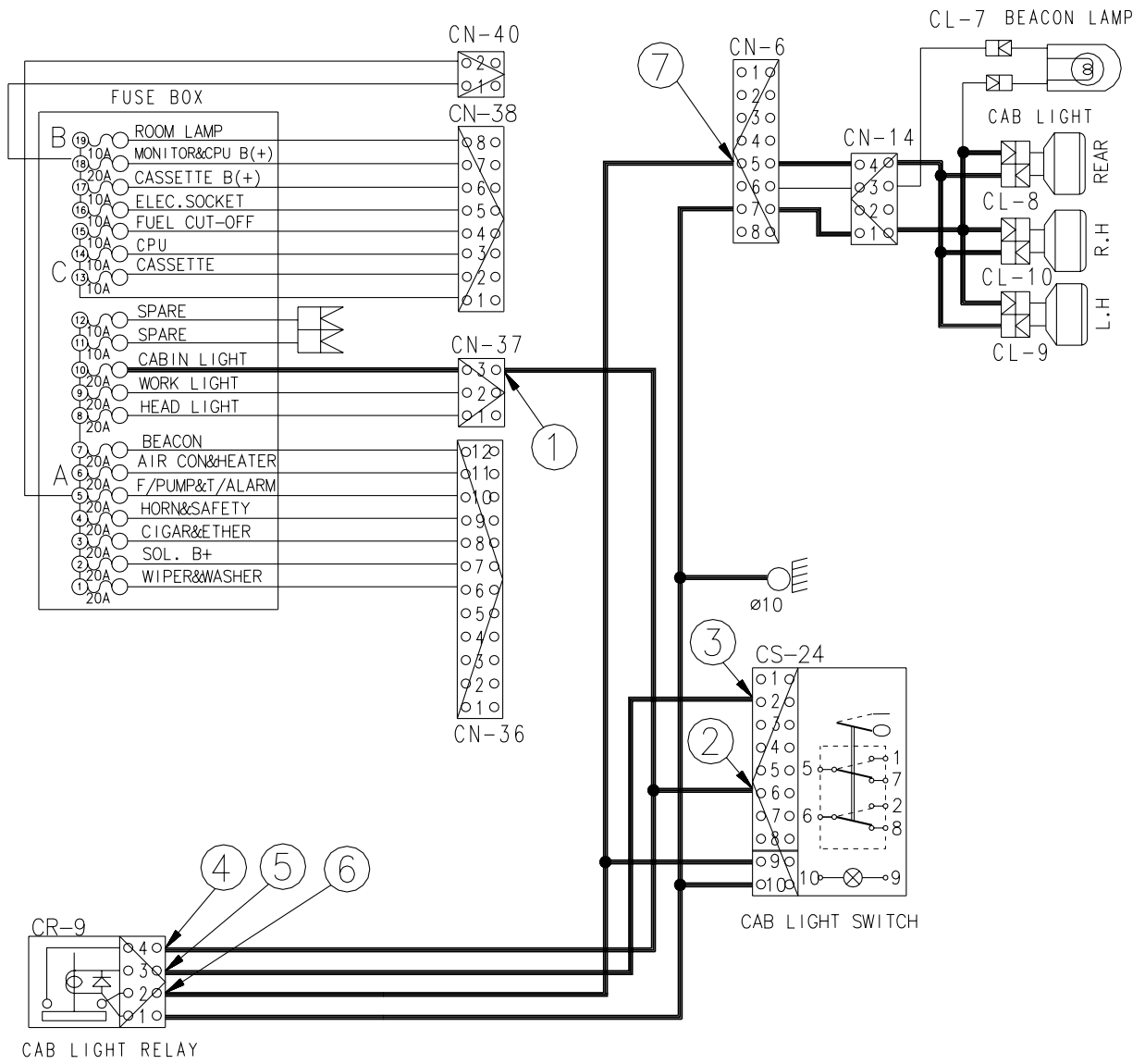

## 7. WIPER MOTOR CIRCUIT

### 1) OPERATING FLOW

#### (1) Wiper motor switch ON

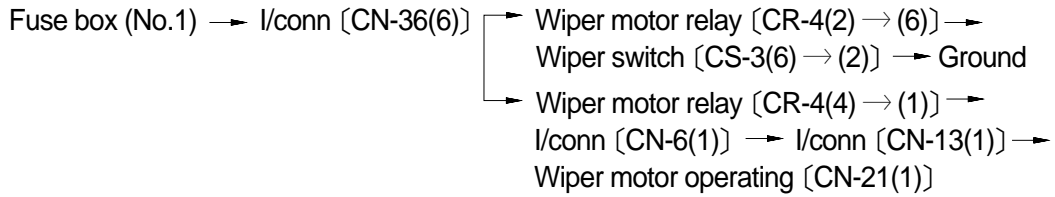

#### (2) Auto - parking (When switch OFF)

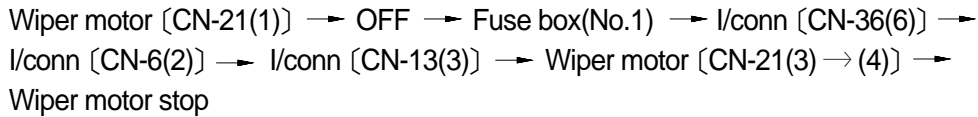

### 2) CHECK POINT

Engine	Key switch	Check point	Voltage
OFF	ON	① - GND (Fuse box) ② - GND (Switch input) ③ - GND (Relay) ④ - GND (Relay coil) ⑤ - GND (Relay input) ⑥ - GND (Relay) ⑦ - GND (Wiper power input) ⑧ - GND (Wiper power input) ⑨ - GND (Wiper motor) ⑩ - GND (Switch output)	20 ~ 25V

※ GND : Ground

# WIPER MOTOR CIRCUIT

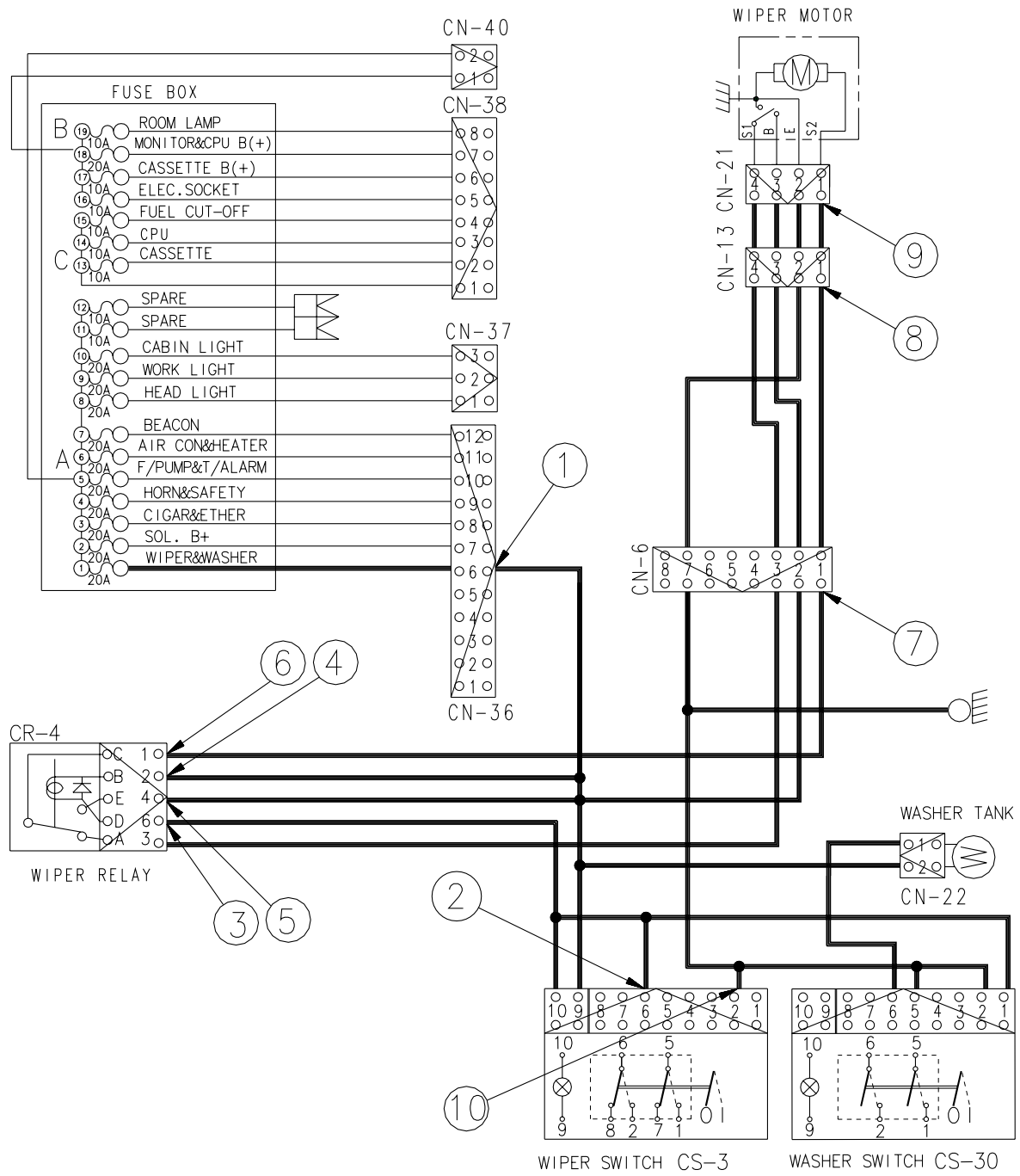

# CONTROLLER CIRCUIT

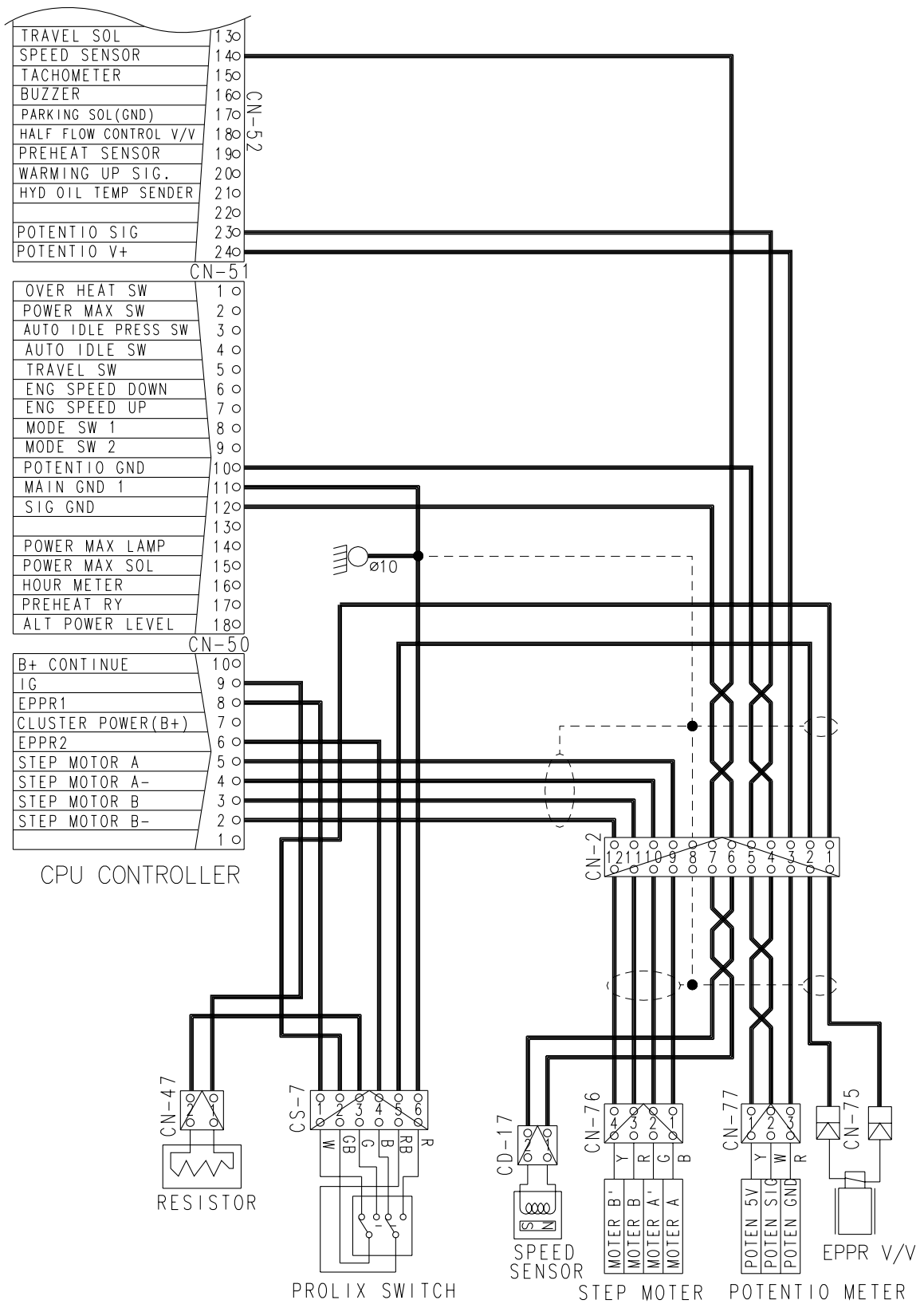



# ELECTRICAL CIRCUIT FOR HYDRAULIC

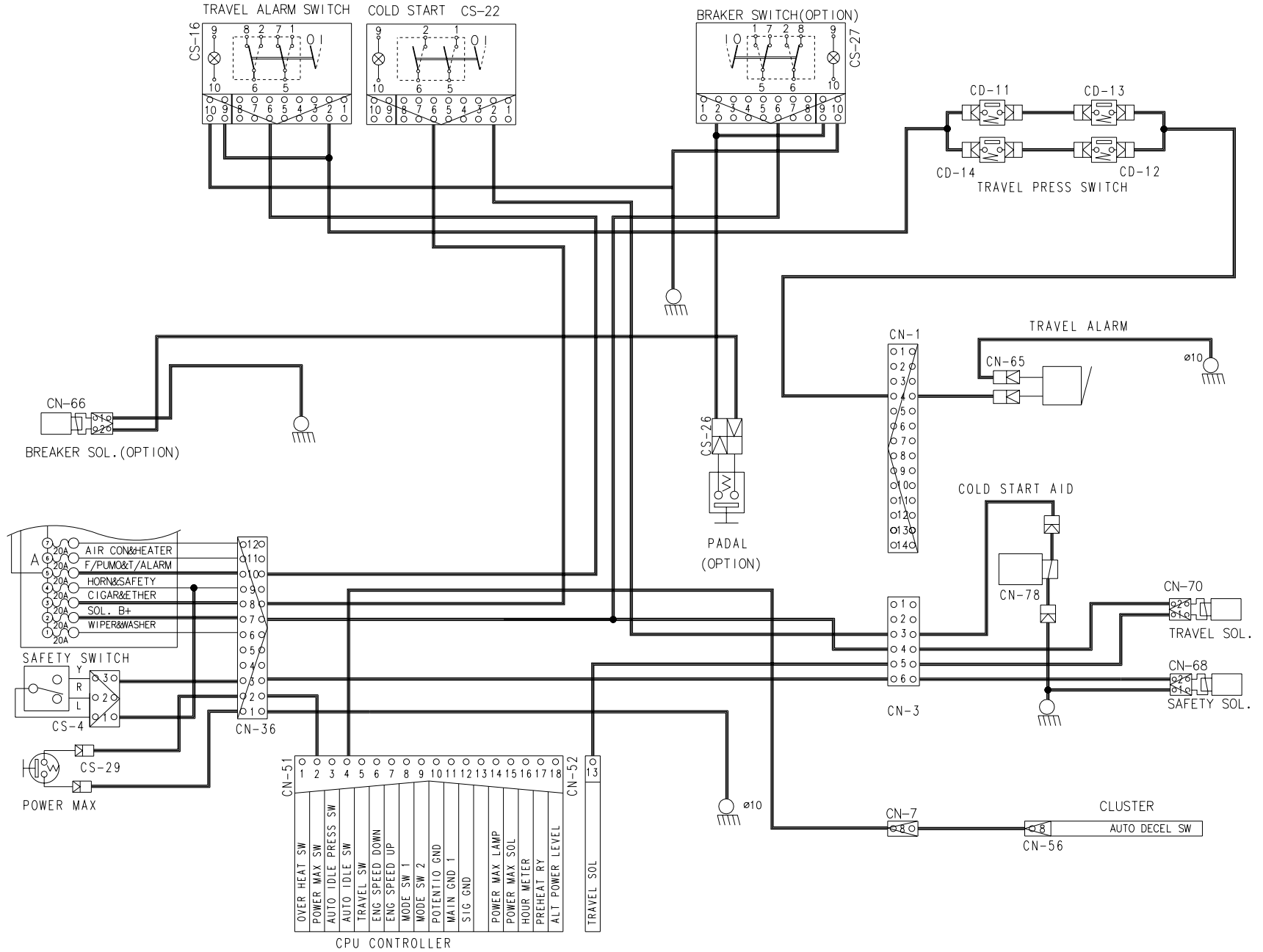

# MONITORING CIRCUIT

