

GROUP 7 WORK EQUIPMENT

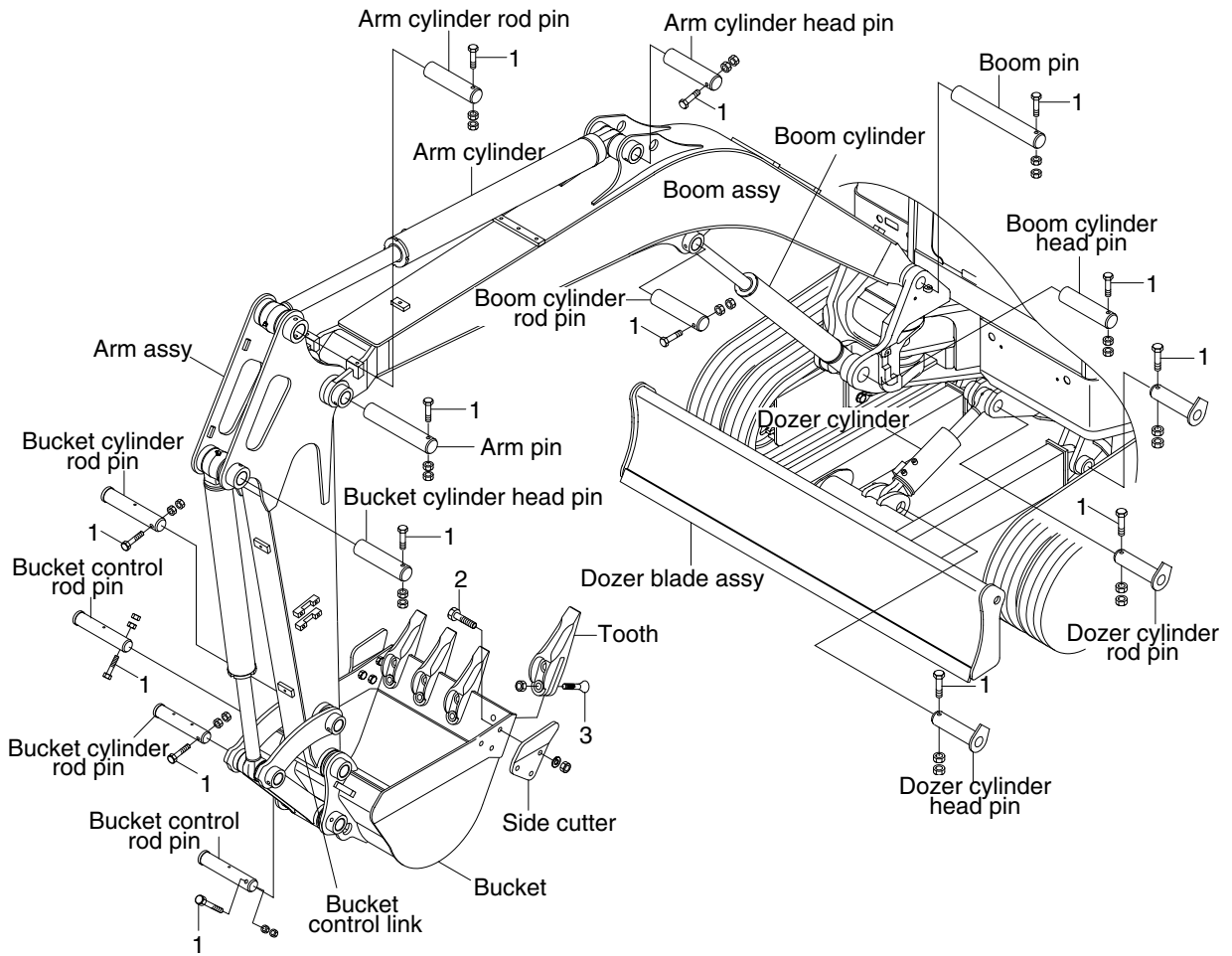

R35Z78CM11

• Tightening torque

| Item | Size | kgf · m | lbf · ft |
|------|----------|----------|-----------|
| 1 | M12×1.75 | 12.8±3.0 | 92.6±21.7 |
| 2 | M16×2.0 | 29.7±4.5 | 215±32.5 |

| Item | Size | kgf · m | lbf · ft |
|------|---------|----------|----------|
| 3 | M16×1.5 | 31.3±4.7 | 226±34 |