

GROUP 4 TRAVEL DEVICE

1. CONSTRUCTION

Travel device consists travel motor and gear box.

Travel motor includes counterbalance valve, parking brake and high/low speed changeover mechanism.

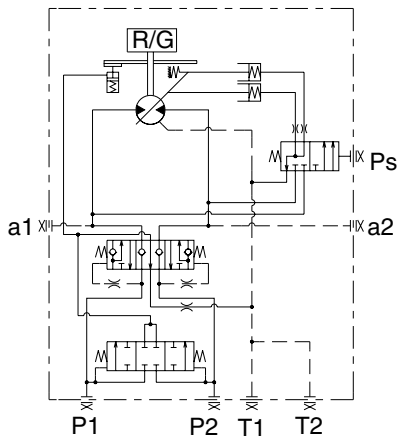
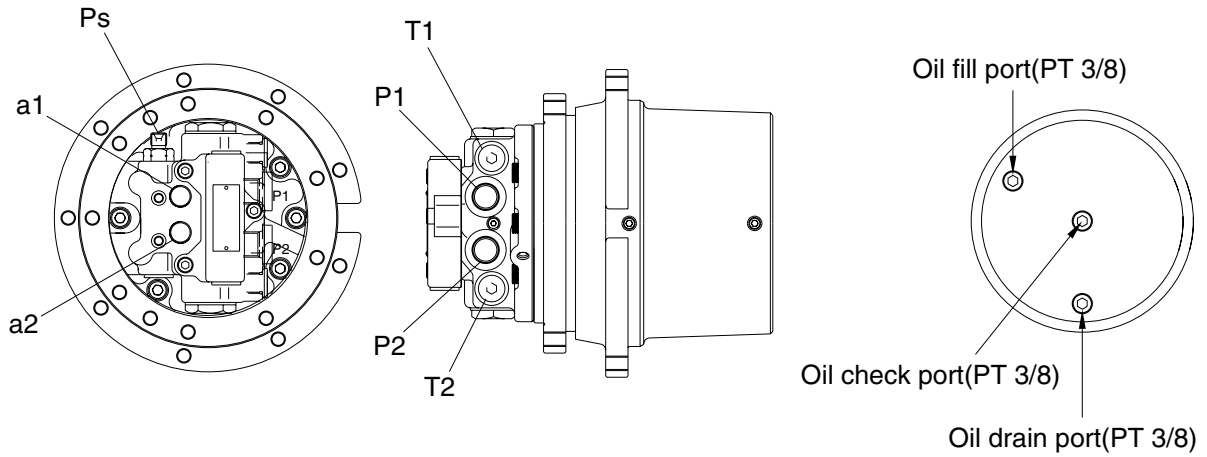

HYDRAULIC CIRCUIT

R35Z72TM20

Port	Port name	Port size
P1	Main port	PF 1/2
P2	Main port	PF 1/2
a1,a2	Gauge port	PF 1/8
T1,T2	Drain port	PF 3/8
Ps	2 speed control port	9/16-18 UNF

1) BASIC STRUCTURE

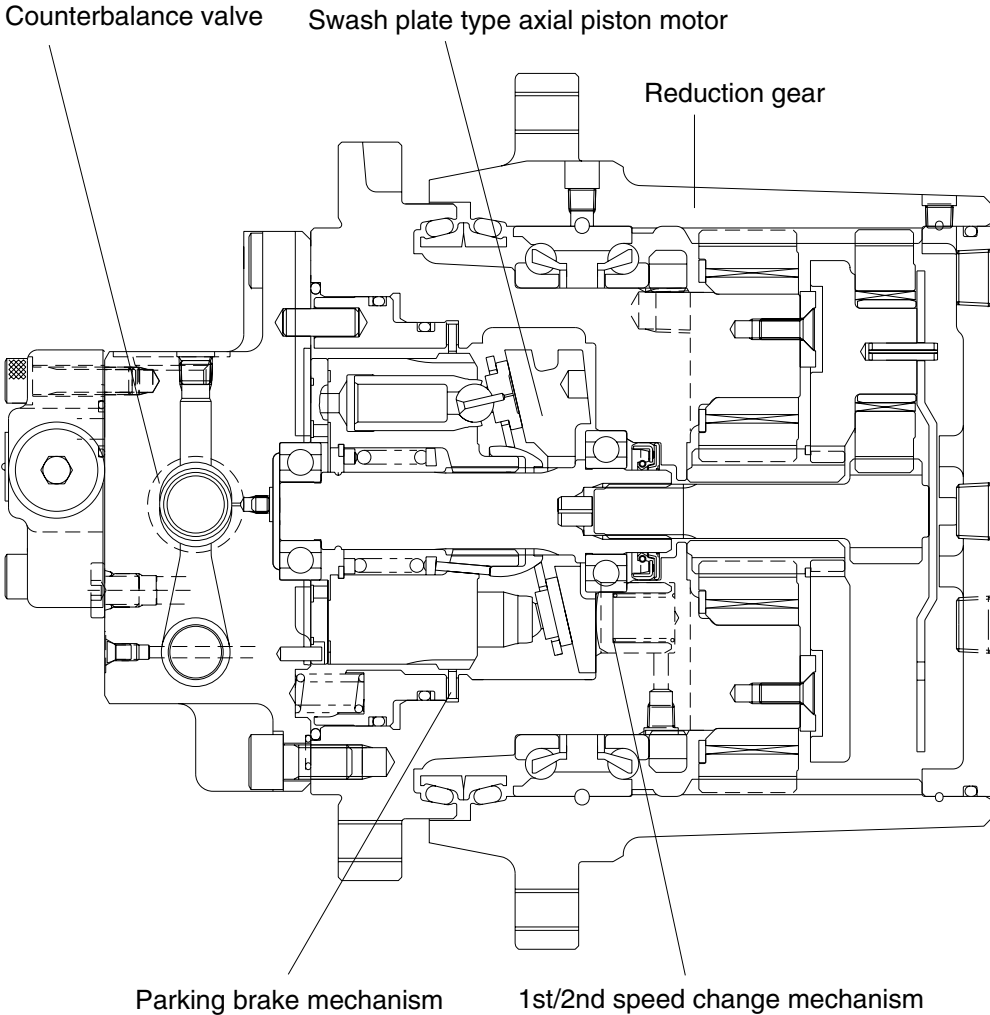

R35Z72TM02

The travel motor is integrated with swash plate type axial piston motor, counterbalance valve, 2 speed change mechanism, parking brake, anti-cavitation valve and reduction gear unit.

2) STRUCTURE

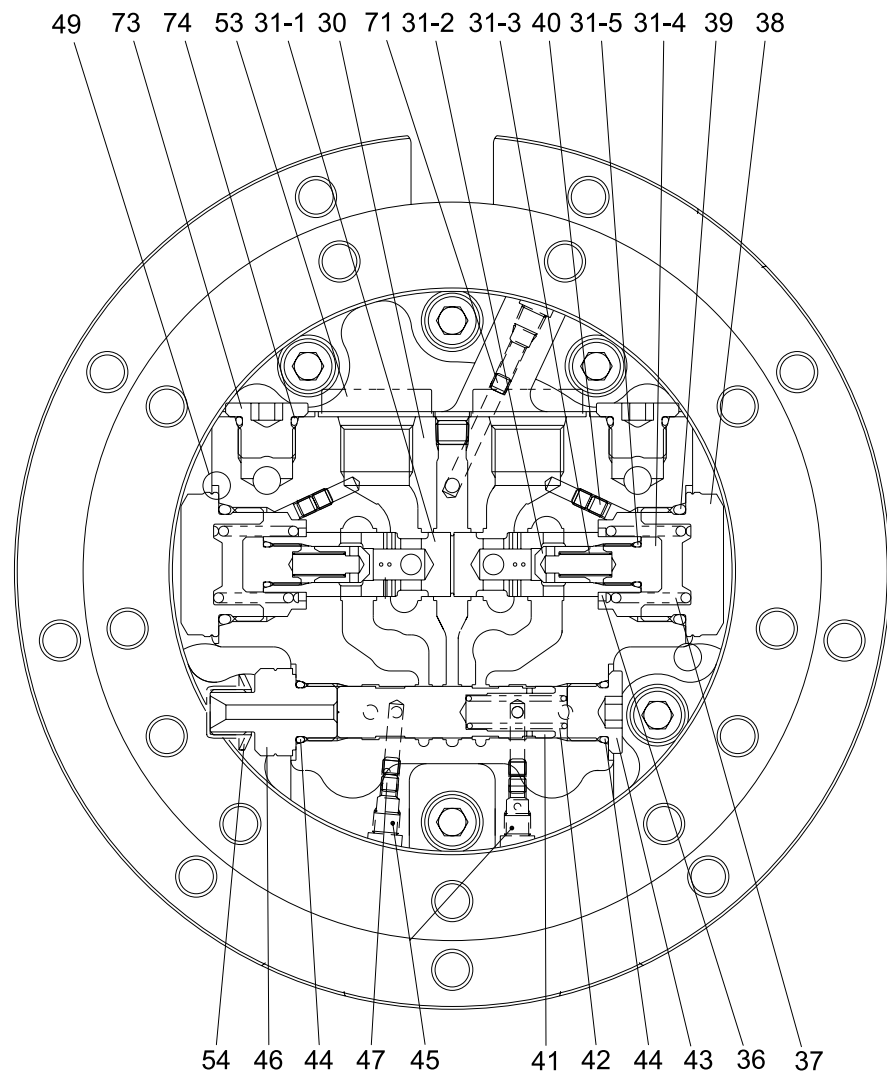

- | | |
|----------------------|-----------------------------|
| 1 Gear box | 1-17 Holder |
| 1-1 Flange holder | 1-18 Planetary gear (A) |
| 1-2 Floating seal | 1-19 Needle bearing |
| 1-3 Angular bearing | 1-20 Inner race |
| 1-4 Ring nut | 1-21 Spring pin |
| 1-5 Plug | 1-22 Drive gear |
| 1-6 Housing | 1-23 Thrust plate (T = 1.8) |
| 1-7 Steel ball | 1-23 Thrust plate (T = 2.3) |
| 1-8 Plug | 1-23 Thrust plate (T = 2.8) |
| 1-9 Planetary gear B | 1-24 Cover |
| 1-10 Needle bearing | 1-25 O-ring |
| 1-11 Collar | 1-26 Wire |
| 1-12 Thrust washer | 1-27 Plug |
| 1-13 Thrust plate | 1-28 Plug |
| 1-14 Screw | 2 Shaft-sub assy |
| 1-15 Sun gear | 3 Ball bearing |
| 1-16 Snap ring | 4 Oil seal |

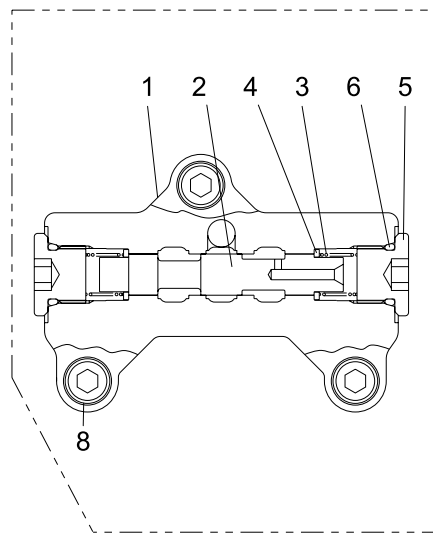

DETAIL OF 2 SPEED
LEAN TURNING PORTION

- | |
|-------------------|
| 5 Swash plate |
| 6 Steel ball |
| 7 Cylinder block |
| 8 Color |
| 9 Spring |
| 10 Washer |
| 11 Snap ring |
| 12 Pin |
| 13 Holder |
| 14 Retainer plate |
| 15 Piston assy |
| 17 Brake piston |
| 19 Piston assy |
| 20 Spring |
| 21 Spring |
| 25 Valve plate |
| 26 Pin |

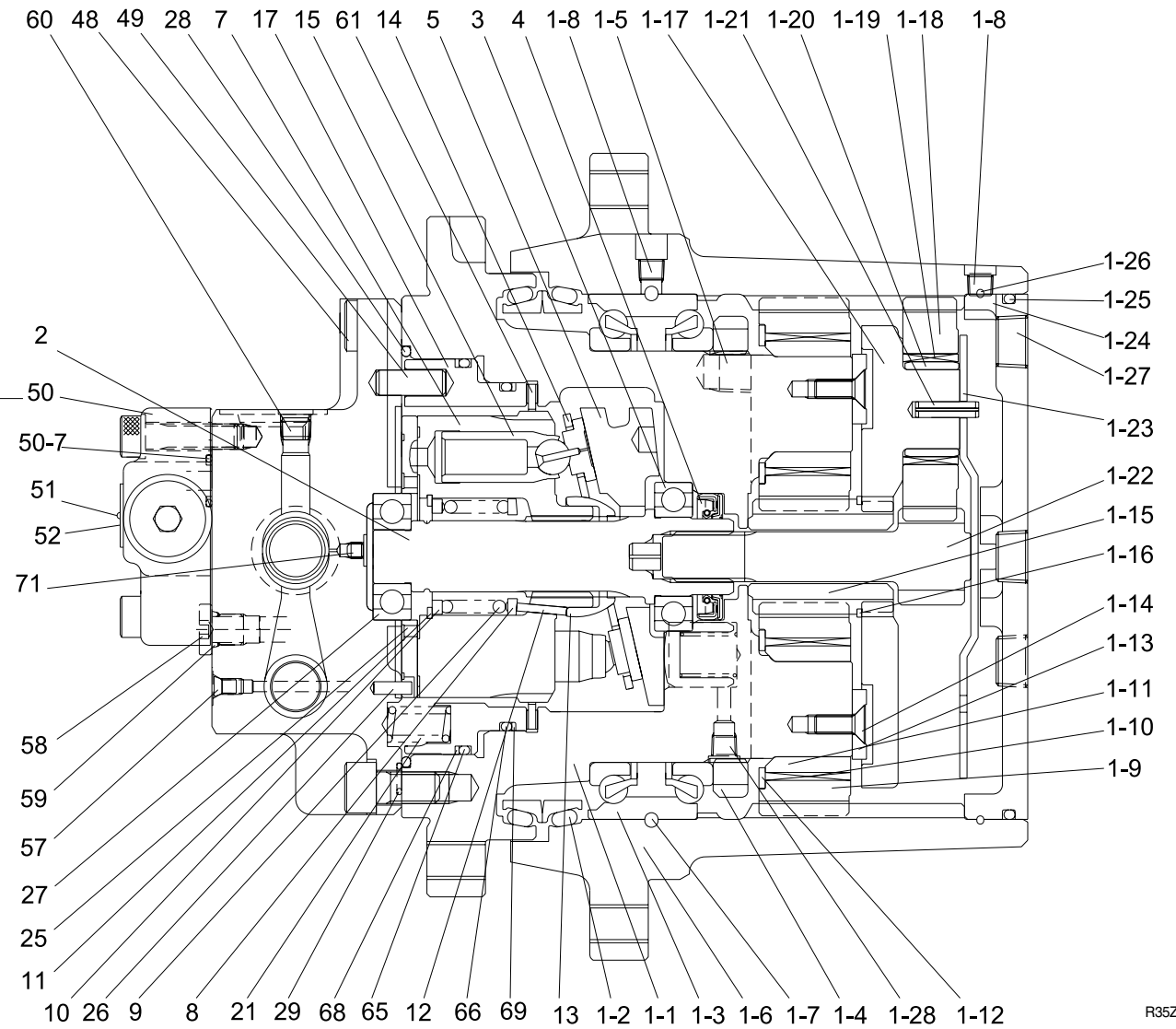

- | | | |
|------------------|-----------------------|-----------------|
| 27 Ball bearing | 43 Plug | 52 Drive screw |
| 28 O-ring | 44 O-ring | 55 Plug |
| 29 O-ring | 45 Plug | 57 O-ring |
| 30 Base plate | 46 Plug | 58 Plug |
| 31 Plunger assy | 47 Orifice | 59 Plug |
| 31-1 Plunger | 48 Socket head bolt | 60 Brake piston |
| 31-2 Check valve | 49 Pin | 61 Disc |
| 31-3 Spring | 50 Valve assy | 62 Spring |
| 31-4 Plug | 50-1 Valve body | 65 O-ring |
| 31-5 O-ring | 50-2 Spool | 66 O-ring |
| 36 Spring seat | 50-3 Spring | 68 Backup ring |
| 37 Spring | 50-4 Spring seat | 69 Backup ring |
| 38 Cap | 50-5 Plug | 71 Spring |
| 39 O-ring | 50-6 O-ring | 73 Plug |
| 40 Orifice | 50-7 O-ring | 74 O-ring |
| 41 Spool | 50-8 Socket head bolt | |
| 42 Spring | 51 Name plate | |

R35Z72TM01

2. FUNCTION

1) HYDRAULIC MOTOR

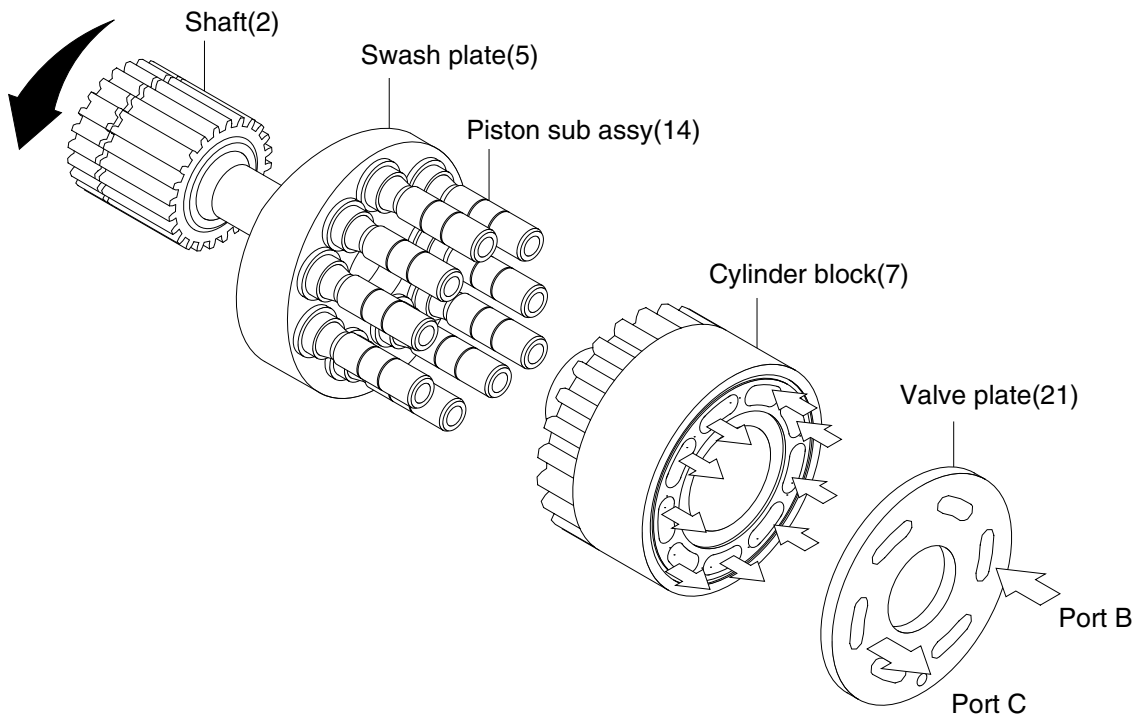

R35Z72TM03

Nine piston assemblies (14) are assembled in cylinder block (7). The end face of cylinder block (7) is in contact with valve plate (21) having two crescent shaped ports, B and C (high and low pressure ports).

When supplying pressure fluid (pressure P) to B port, swash plate (5) is pushed by the force of piston sub assemblies having $F = P_i / A$ (A : piston pressure area). Piston assemblies receive the reaction force against it, and produce the reaction force (F_t) in rotating direction. The total force of high pressure side piston assemblies in rotating direction produces a rotating force in the cylinder block, and the torque is transmitted to shaft (2) through the spline resulting in the rotation of the shaft.

According to the above working principle, the output torque and rotating speed of the piston motor are determined by supply pressure (P) and flow rate (Q), and are calculated by the following equation.

$$T = \frac{P \times D \times \eta_m}{2 \times \pi}$$

$$N = \frac{Q \times 10^3 \times \eta_v}{D}$$

T : Output torque [N · m]

N : Speed of rotation [rpm]

P : Working pressure [MPa]

Q : Flow rate [L/min]

D : Theoretical displacement [cm^3/rev]

η_m : Mechanical efficiency

η_v : Volumetric efficiency

2) COUNTERBALANCE VALVE

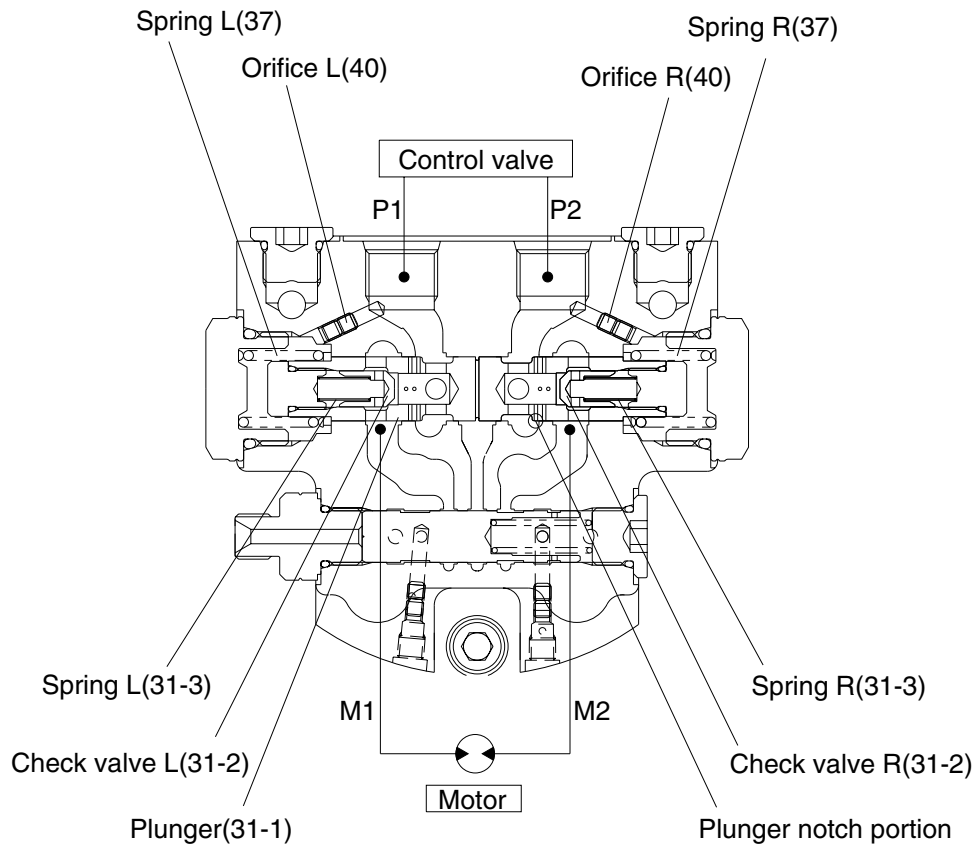

R35Z72TM04

The counterbalance valve is provided to stop the axial piston motor and to prevent overrun. When the control valve is set to the neutral position, there is no pressure in the ports P1 and P2, and ports M1 and M2 are blocked by plunger (31-1) and check valve (31-2), consequently the motor does not start rotating.

(2) Brake work

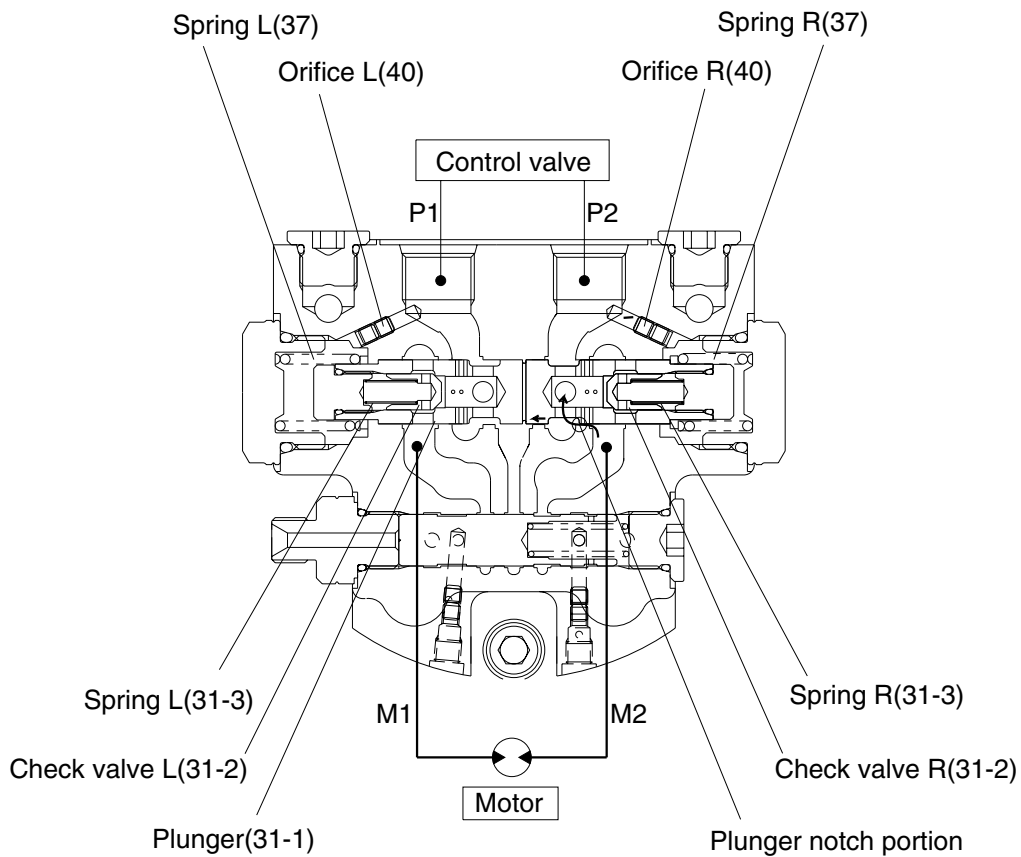

R35Z72TM06

Then, when the control valve returns to the neutral position, the pressurized oil from the pump is shut off and the pressures of the ports P1 and P2 become equal. Plunger (31-1) tries to be returned to neutral position by force of spring R (37). When plunger (31-1) moves, the throttle opening of plunger becomes small.

Piston motor tries to rotate with inertia energy (pumping action of motor) and the pressure rises on port M2.

With the movement of plunger (31-1), the oil of spring L room flows out through orifice L (40) and control the speed of plunger (31-1), By this movement, the shock pressure due to the inertia energy on the port M2 is absorbed, simultaneously preventing the cavitation on the port M1.

3) TWO SPEED CHANGE MECHANISM

(1) When running at 1st speed (low speed)

Swash plate (5) has three faces, from "a" to "c", as shown below in the figure and installed in the flange holder that is piston motor housing with two steel balls (6) in the condition where it can be tilted.

When the control valve is set to the 1st speed position, spool (41) is placed in the position shown below in the figure by the force of spring (42), and the passage of swash plate control piston (19) passes across the Pi1 and Pi2 port positions and led to the tank port. Therefore, the force pushing up the swash plate control piston (19).

$$F_p = (A_p \times P) = 0$$

F_p : Swash plate control piston thrust

A_p : Swash plate control piston pressure receiving area

P : Pressure

When steel ball (6) is placed on the tilting center, the balance of moment acting on swash plate (5) is in the condition of $(\Sigma F + F_{s1}) \times L_1 > (F_p + F_{s2}) \times L_0$ depending on the total ΣF of driving force of piston sub assy (15) and the force of spring (9) F_{s1} and F_{s2} , then swash plate (5) stables at the face a and the swash plate angel is α , and consequently the motor speed corresponding to the 1st speed, low speed, is obtained.

$$(\Sigma F + F_{s1}) \times L_1 > (F_p + F_{s2}) \times L_0$$

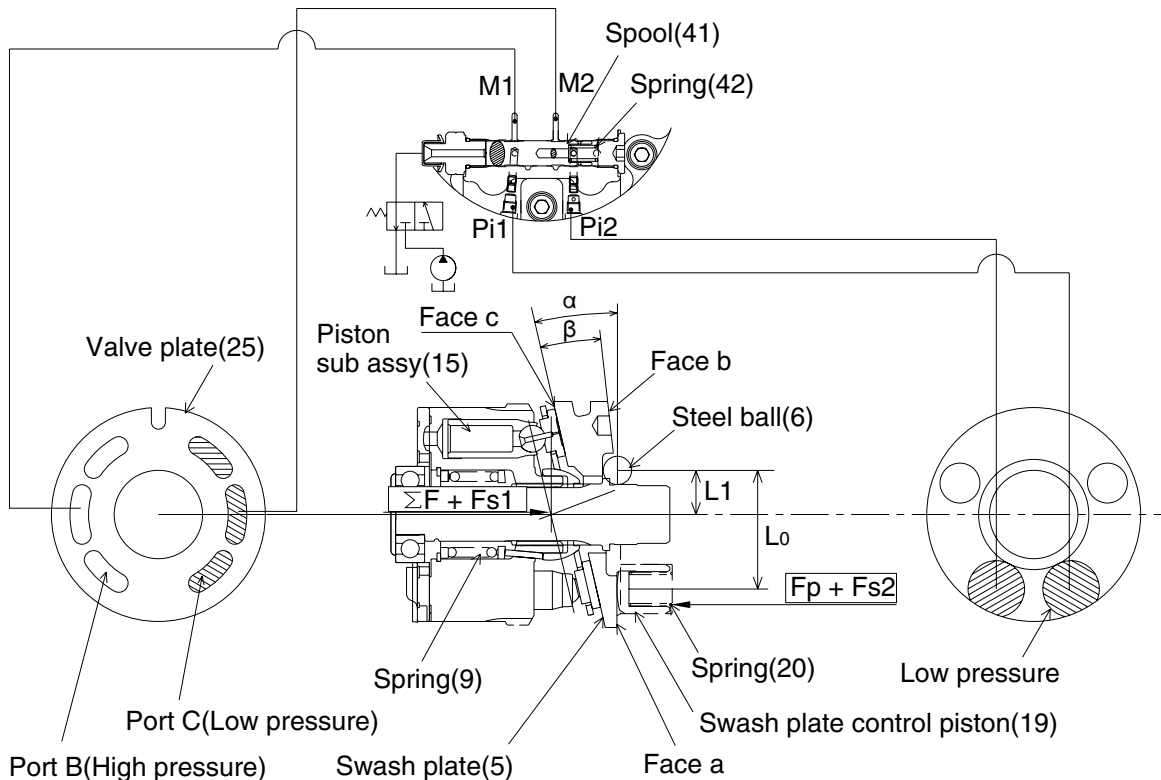

At 1st speed(low speed)

R35Z72TM08

(2) When running at 2nd speed (high speed)

When control valve is set to the 2nd speed position, the pressure oil delivered by the pump is led to spool (41) and spool (41) is switched to the position shown below in the figure. And the pressurized oil flows into each ports Pi1 and Pi2 through ports M1 and M2 and the motor driving pressure (P1 : high pressure and P2 : low pressure) is led to each swash plate control piston (19). Therefore the force pushing up the swash plate acts on swash plate control piston (19).

$$F_{p1} = A_p \times P1 \qquad F_{p2} = A_p \times P2$$

When steel ball (6) is placed on the tilting center, the balance of moment acting on swash plate (5) is in the condition of $(\Sigma F + F_{s1}) \times L1 < (F_p + F_{s2}) \times L_o$ depending on the total ΣF of driving force of piston sub assy (15).

The face "b" of swash plate (5) stabilizes and the swash plate angle become β , consequently the motor speed is the 2nd speed (high speed).

While the engine is stopped, spool (41) is returned to the 1st speed position by the force of spring (9) since pressurized oil does not flow. When steel ball (6) is placed on the tilting center, the balance of moment acting on swash plate (5) is in the condition of $F_s \times L1 > F_p \times L_o$, the face "a" of swash plate (5) stabilizes and the swash plate angle become α , consequently the motor speed at starting is always the 1st speed.

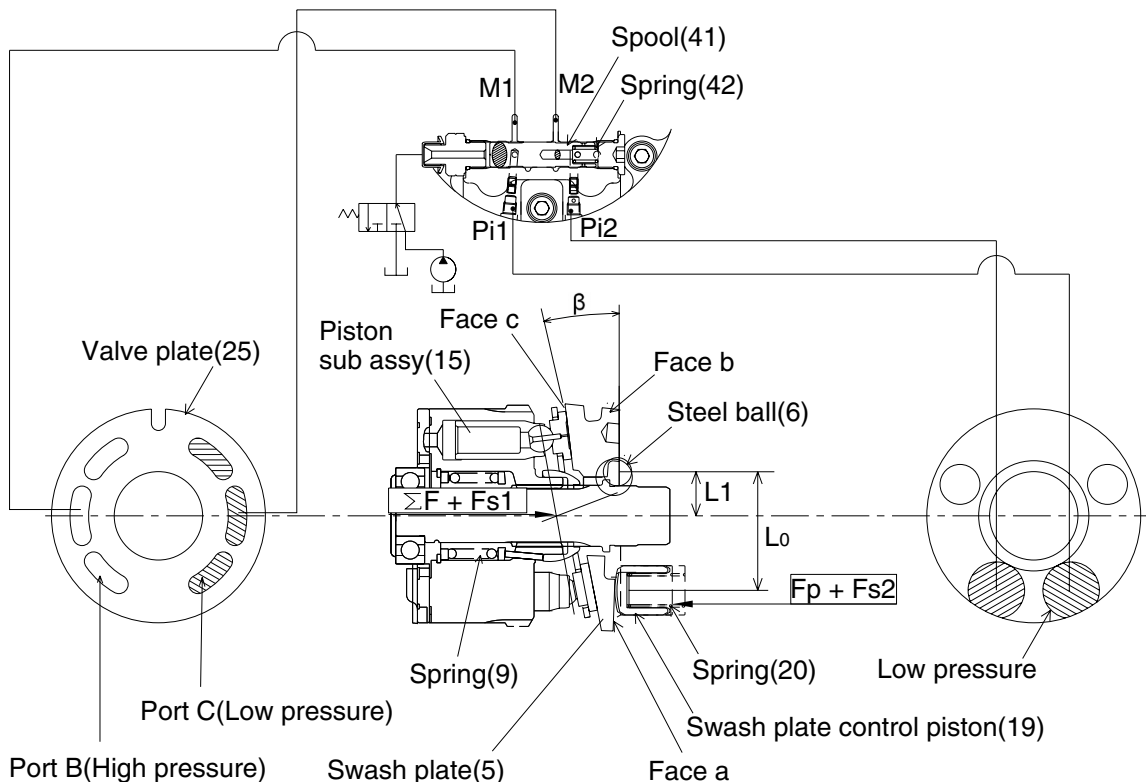

At 2nd speed (high speed)

4) AUTO TWO SPEED CHANGE MECHANISM

Auto two speed control mechanism consists of two spools and spring. This valve automatically changes motor displacement in portion to motor pressure. This valve works while the pilot port Ps is pressurized.

(1) Motor pressure is low

The motor displacement is small (high speed displacement) as shown in the figure.

When the two speed spool is on the right position, motor pressure PM1 and PM2 are connected to each side of chamber of two speed piston. So swash plate is moved to high speed position by two speed piston and motor displacement is kept on high speed position.

Pilot pressure is applied on the area A_p when P_s port is pressurized. Then the pressure of P_s pushes the spool to the right direction on the figure. At the same time, motor inlet pressure is applied on the area A_m . So, the spool is also applied to the left direction by A_m pressure. According to above, if the motor pressure is lower and keep the following condition, the spool stay on the right position.

$$P_s \times D_p > A_m \times P_{in} + K_x$$

K_x : the force of spring

Motor pressure is low : $(A_p \times P_s) > (A_m \times P_{in} + K_x)$

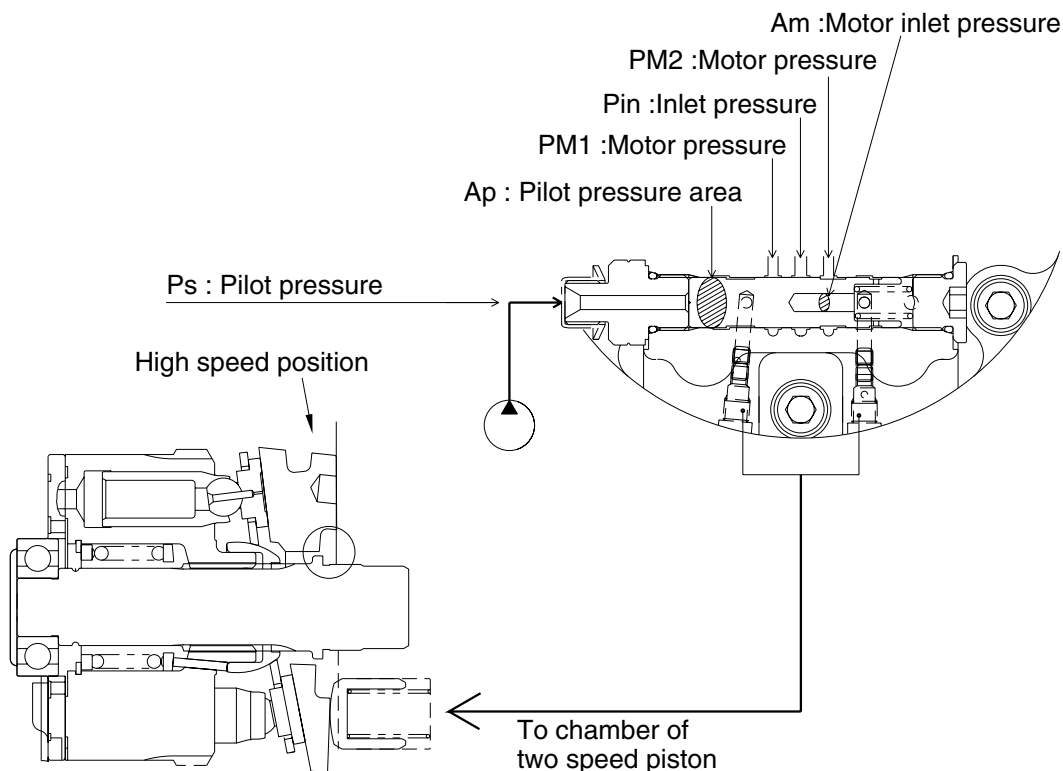

Automatic two speed (Motor pressure is low)

R35Z72TM11

(2) Motor pressure is high

The motor displacement is large (low speed displacement) as shown in the figure.

The two speed spool is on the left position if Pin pressure is high. Then, PM1 and PM2 are shutted by the spool. If the motor pressure is higher and keep the following condition, the spool stay on the left position.

$$P_s \times D_p > A_m \times P_{in} + K_x$$

Motor pressure is high : $(A_p \times P_s) < (A_m \times P_{in} + K_x)$

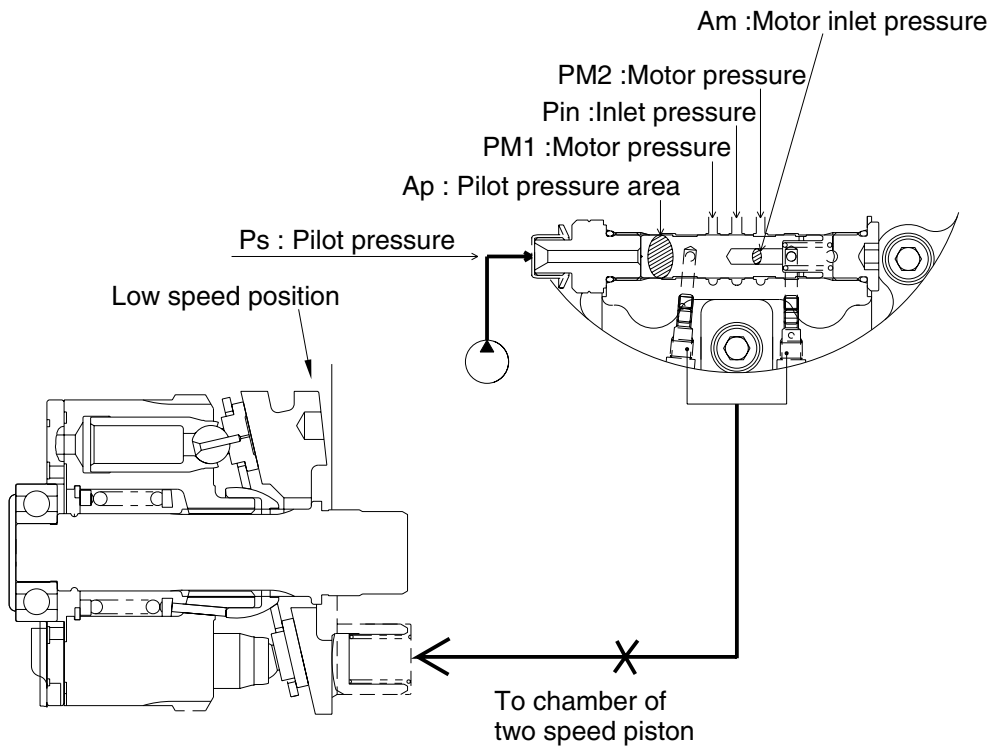

Automatic two speed (Motor pressure is high)

R35Z72TM09

5) ANTI CAVITATION VALVE (With parking brake)

Anti cavitation valve is always working with counterbalance valve.

This system consists of oil passage "A", "B", "C" and spool in addition to traditional counterbalance valve.

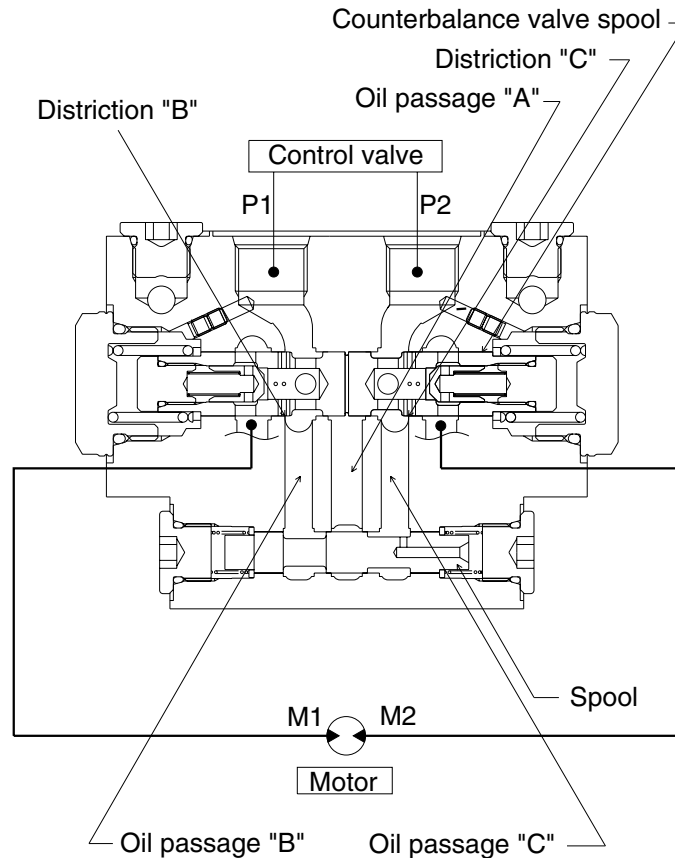

Anti cavitation valve system

R35Z72TM12

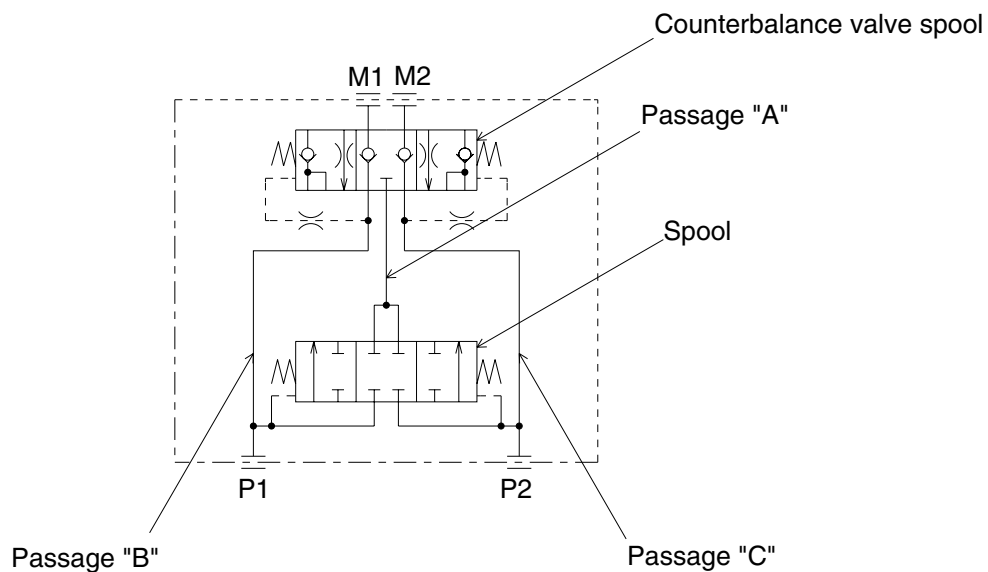

Hydraulic circuit

R35Z72TM17

(1) From stopping to starting (high speed)

Counterbalance valve spool is moved to right position by the force of spring when port P1 is pressurized. According as the movement of spool, P1 connects to M1 and M2 connects to P2. Consequently the motor work. At the same time, oil passage A is selected high pressure, however, there is no oil flow to oil passage C because of the movement of spool.

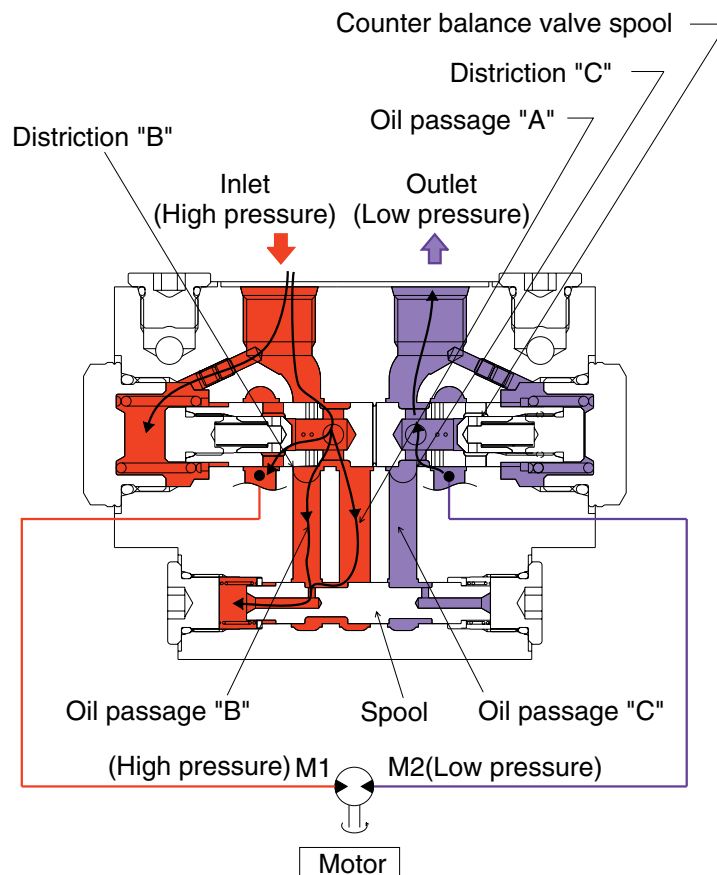

R35Z72TM13

(2) Continuous rotating

In case of continuous rotating, the oil passage A is also selected high pressure, however, there is no oil flow to oil passage C. So, anti cavitation valve has no influence during motor operation.

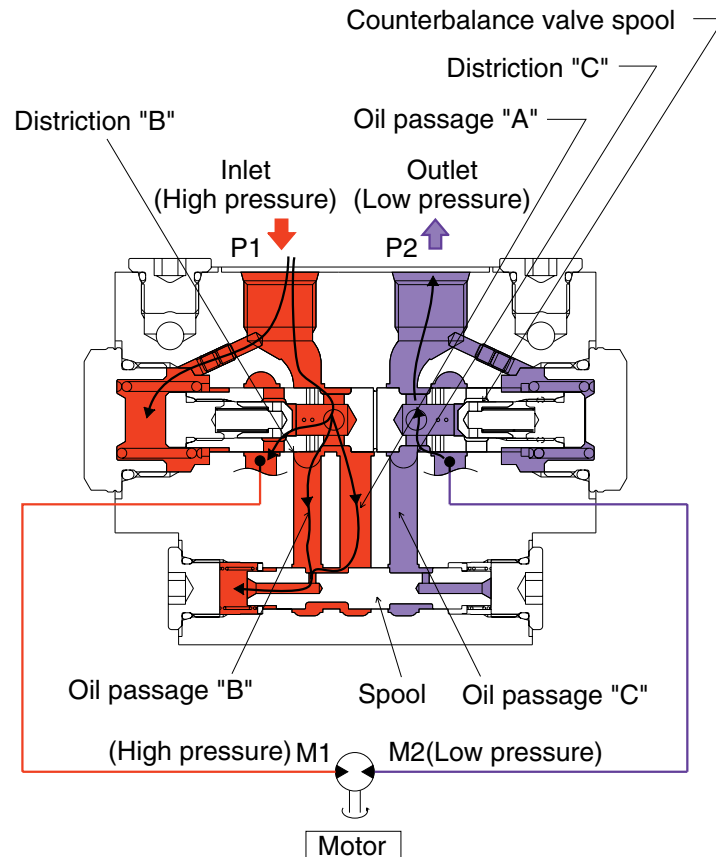

R35Z72TM14

(3) From continuous rotating to deceleration

At deceleration, the motor is still rotated by inertia. The oil flows M2 port to P2 port during counterbalance valve is opened. Then, if the flow to P1 is not enough, the cavitation could be appeared in P1-M1 line.

Anti cavitation valve can make a oil passage like $M2 \rightarrow C \rightarrow \text{spool} \rightarrow A \rightarrow P1 \rightarrow M1$ and supply flow before counterbalance valve spool is returned. Consequently the cavitation is reduced by the above function.

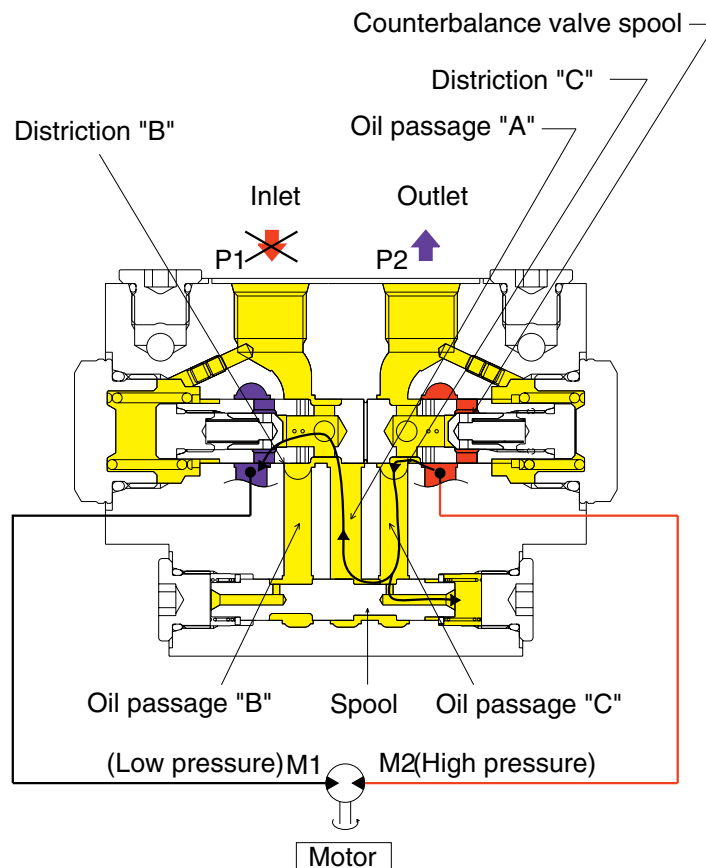

R35Z72TM15

(4) From deceleration to stopping

Anti cavitation valve works until oil passage from A to P1 is shut.

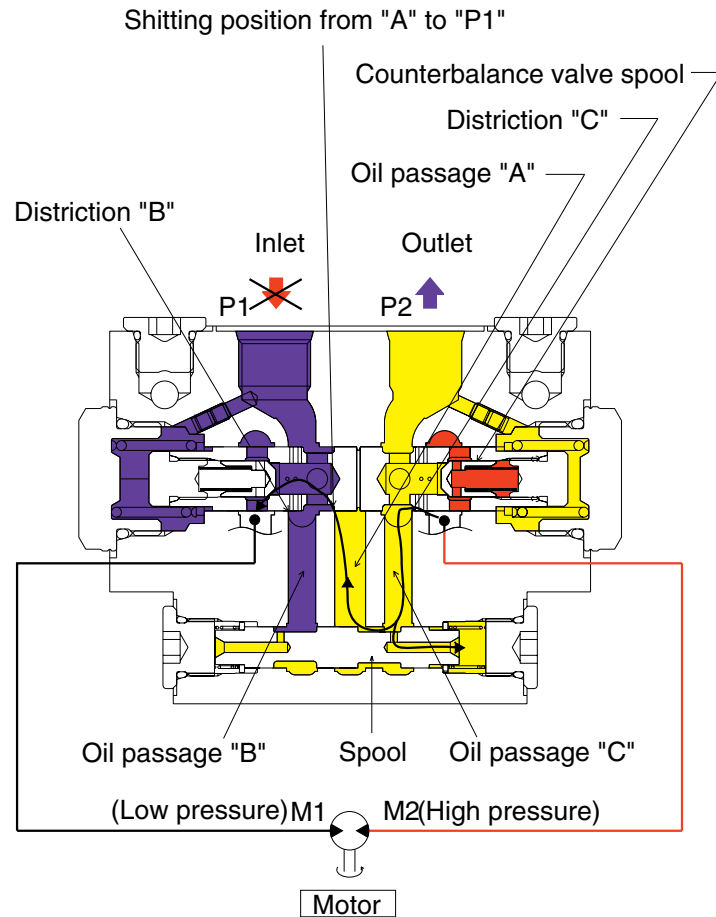

R35Z72TM16

6) PARKING BRAKE

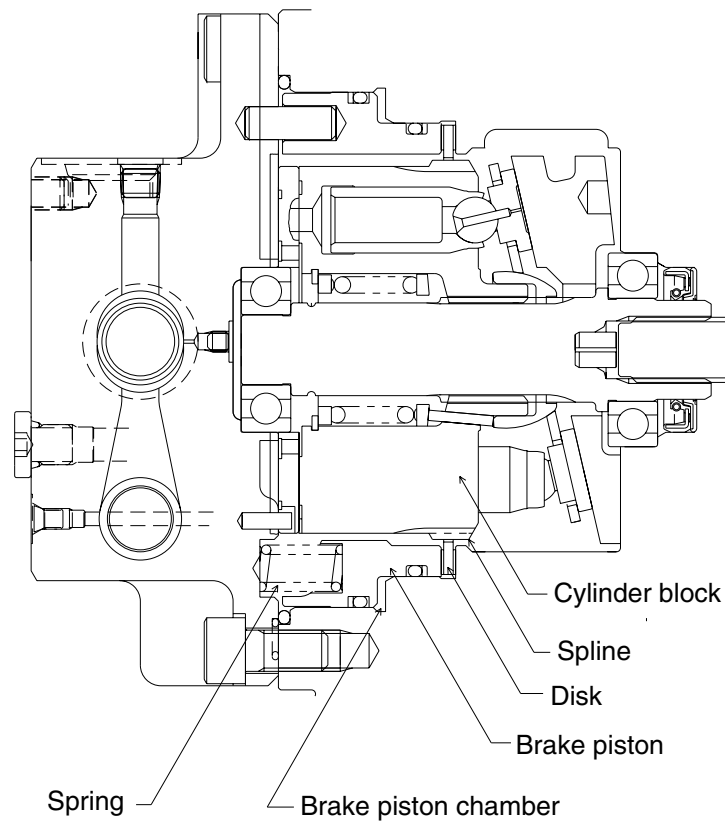

R35Z72TM18

The parking brake is a kind of negative brake which consist of disk, brake piston and spring.

The cylinder block and disk are combined with a spline, and friction material is bonded on both sides of disk. The disk generates frictional force between the flange holder and the brake piston by the force of spring and restricts the rotating force of the motor, achieving the best performance of the parking brake.

When the pressurized oil flows into the motor, the plunger moves and the parking brake release port is opened. After the oil flows into brake piston chamber, the thrust F is generated, corresponding to the pressure receiving surface of brake piston and the thrust F becomes larger than the force of spring F , consequently the brake piston moves toward right.

Then, the disk rotates freely between the flange holder and brake piston, and parking brake is released.

When the motor is stopped, the plunger returns to the neutral position and the parking brake release port is closed. Consequently the pressurized oil in brake piston chamber flows into motor case, the parking brake acts by the force of spring.

7) REDUCTION UNIT

The reduction unit consists of double stage planetary gear mechanism.

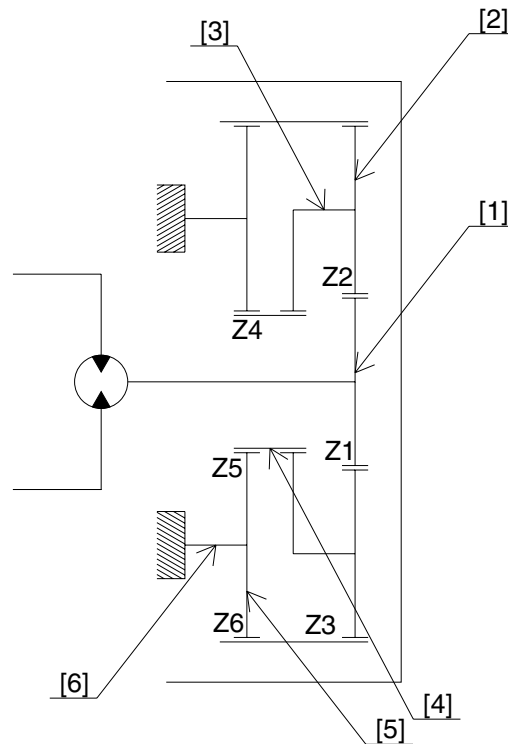

R35Z72TM19

Drive gear [1] is engaged with the 1st planetary gear [2], 2nd stage sun gear [4] is engaged with the 2nd planetary gear [5]. The 2nd stage planetary carrier [6] is fixed machine body. Planetary gears [2], [5] are engaged with ring gear (housing).

The driving force from the piston motor is transmitted to drive gear [1], and the speed is reduced by each gear.

The reduced driving force is transmitted to ring gear through planetary gear [5] of planetary carrier [6] fixed on the machine body. (The driving force is also transferred from 1st stage planetary gear [2]). The direction of output rotation are reversed against that of input rotation.

The reduction gear ratio " i " is shown as follows.

※ Reduction gear ratio (i)

$$i = (i_1 \times i_2 - 1) = \left(\frac{Z_1 + Z_3}{Z_1} \times \frac{Z_4 + Z_6}{Z_4} - 1 \right)$$

※ Output torque of reduction unit (T)

$$T = T_M \times i \times \eta_M$$

Z1 : Drive gear teeth number

Z2 : Ring gear teeth number

Z4 : Sun gear teeth number

Z6 : Ring gear teeth number

※ Reduction gear output rotating speed (N)

$$N = \frac{NM}{i}$$

T_M : Input torque (motor output torque)

i : Reduction gear ratio

η_M : Mechanical efficiency

N_M : Input speed of rotation (output motor speed)