

GROUP 3 TRACK AND WORK EQUIPMENT

1. TRACK SHOE

1) STEEL SHOE SPEC

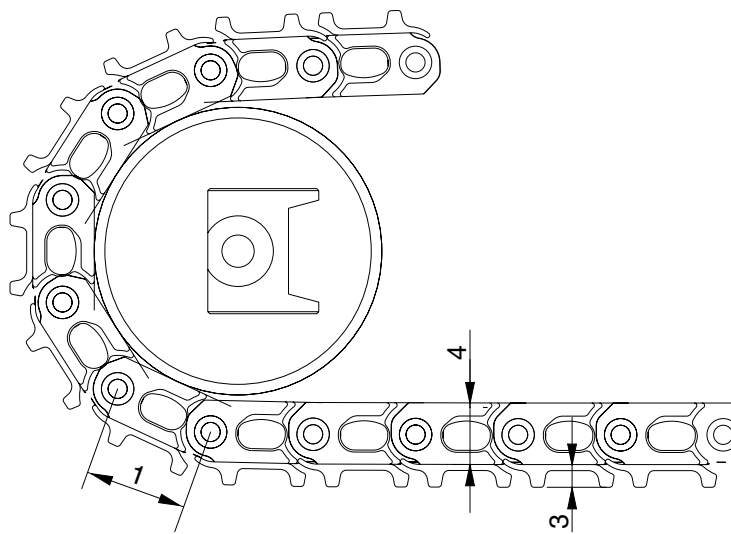
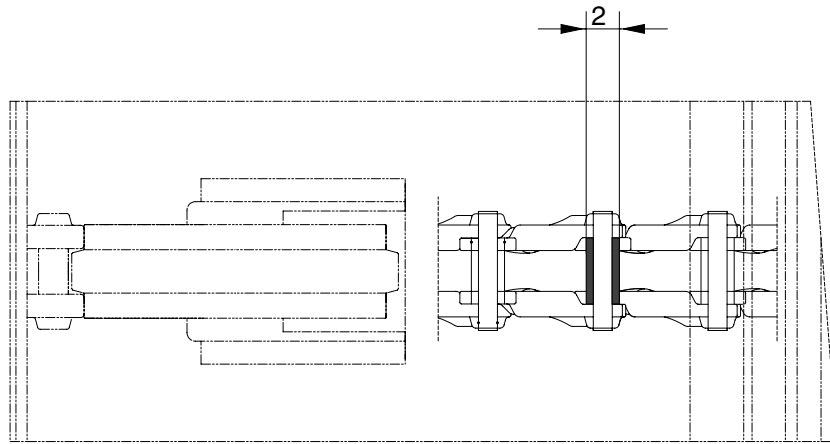

R35Z76MC18

Unit : mm

No	Check item	Criteria		Remedy
		Standard size	Repair limit	
1	Link pitch	101.6	105.0	Replace bushing and pin and link assembly
2	Outside diameter of bushing	32.17	28.77	
3	Height of grouser	16.5	12.5	Lug welding, rebuild or replace
4	Height of link	61	56	

2) RUBBER SHOE SPEC

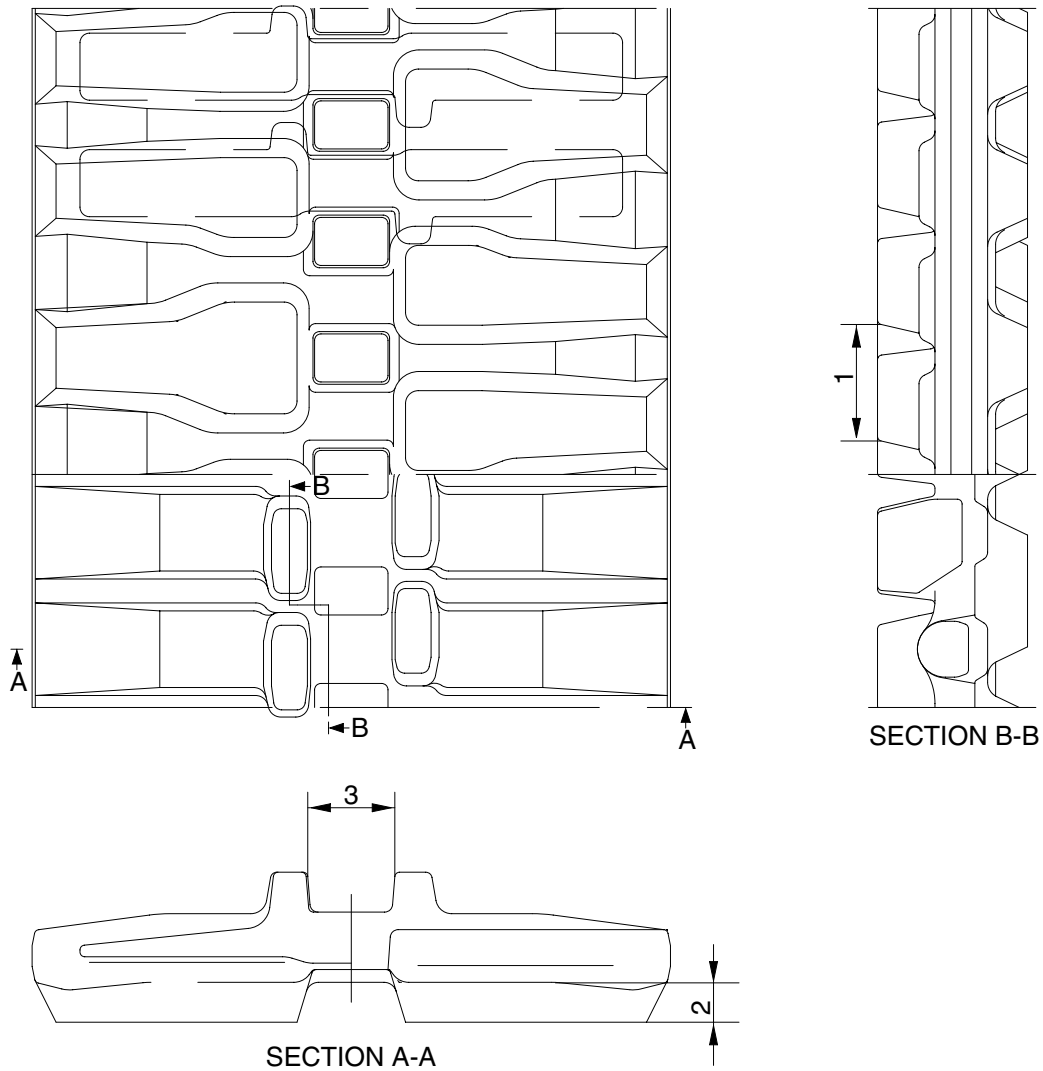

R5576MC17

Unit : mm

No	Check item	Criteria		Remedy
		Standard size	Repair limit	
1	Link pitch	52.5	54.5	Replace
2	Height of grouser	23.5	5	
3	Width of link	34	46	

2. IDLER

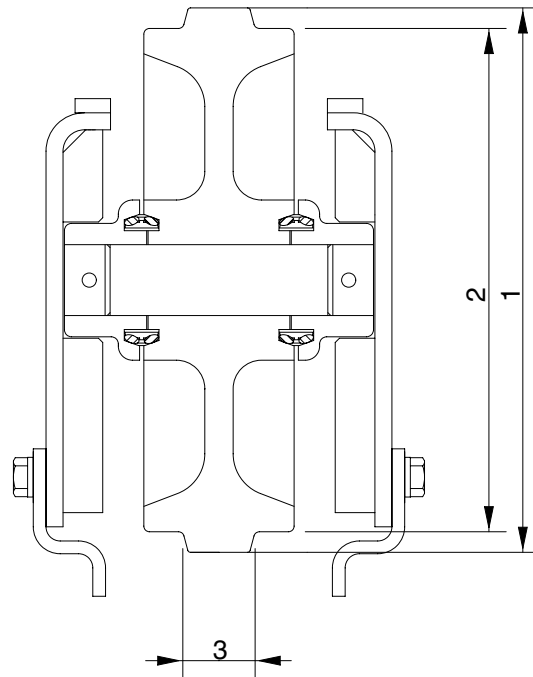

R5576MC18

Unit : mm

No	Check item		Criteria		Remedy
			Standard size	Repair limit	
1	Outside diameter of flange	Steel	293	-	Rebuild or replace
		Rubber	327	-	
2	Outside diameter of thread	Steel	269	263	
		Rubber	285	279	
3	Width of flange		26.2	20.2	

3. TRACK/CARRIER ROLLER

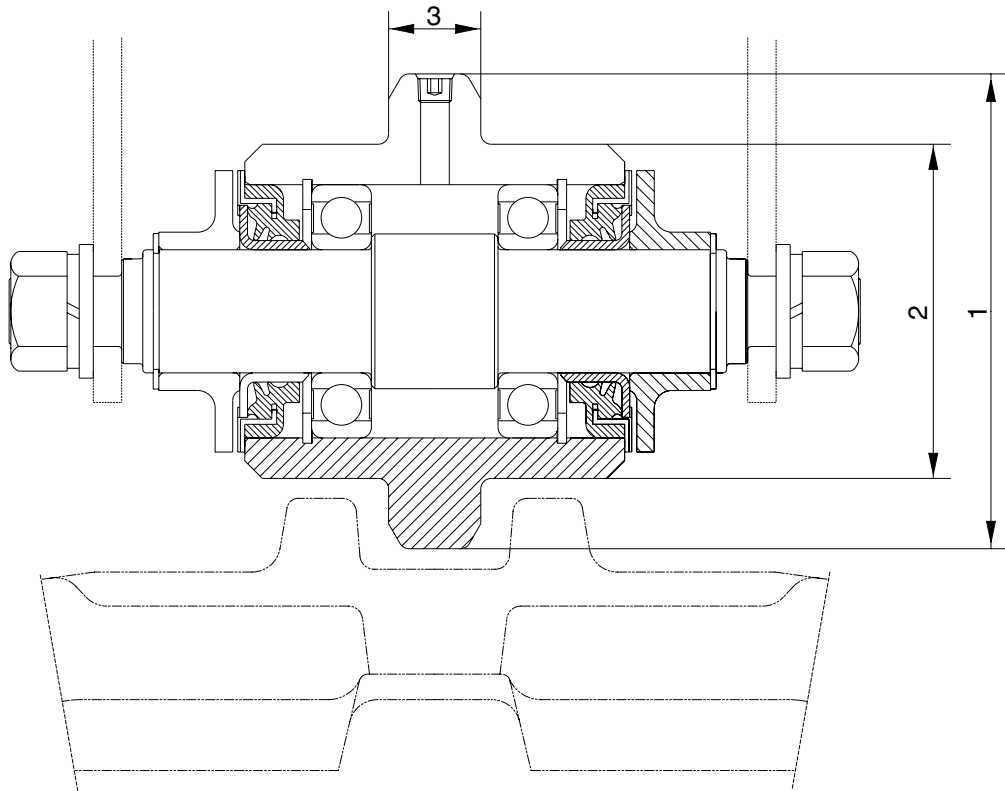

R35Z76MC19

Unit : mm

No	Check item		Criteria		Remedy
			Standard size	Repair limit	
1	Outside diameter of flange	Steel	131	-	Rebuild or replace
		Rubber	135	-	
2	Outside diameter of thread	Steel	107	101	
		Rubber	95	89	
3	Width of flange		26.2	20.2	

4. CARRIER ROLLER

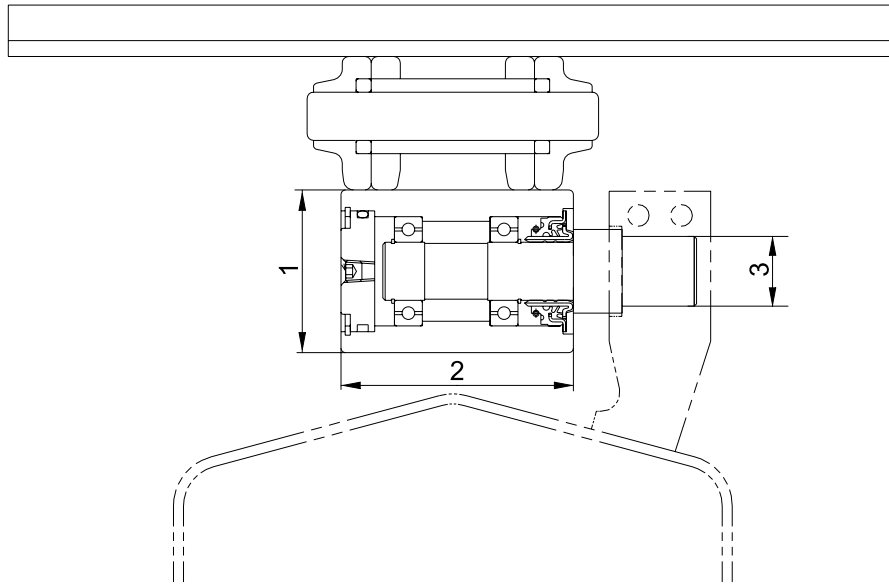

R35Z76MC20

Unit : mm

No.	Check item	Criteria		Remedy
		Standard size	Repair limit	
1	Outside diameter of flange	ø 70	ø 66	Replace
2	Width of tread	ø 100	-	
3	Diameter of shaft	ø 30	-	

5. TENSION CYLINDER

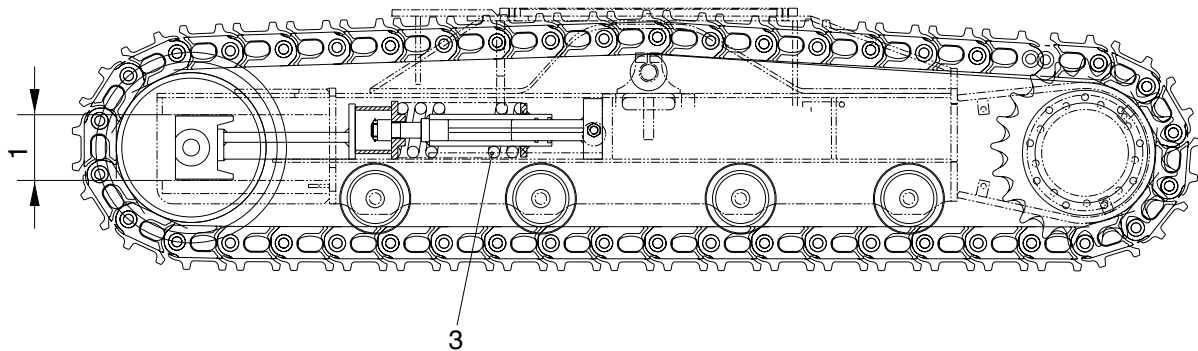
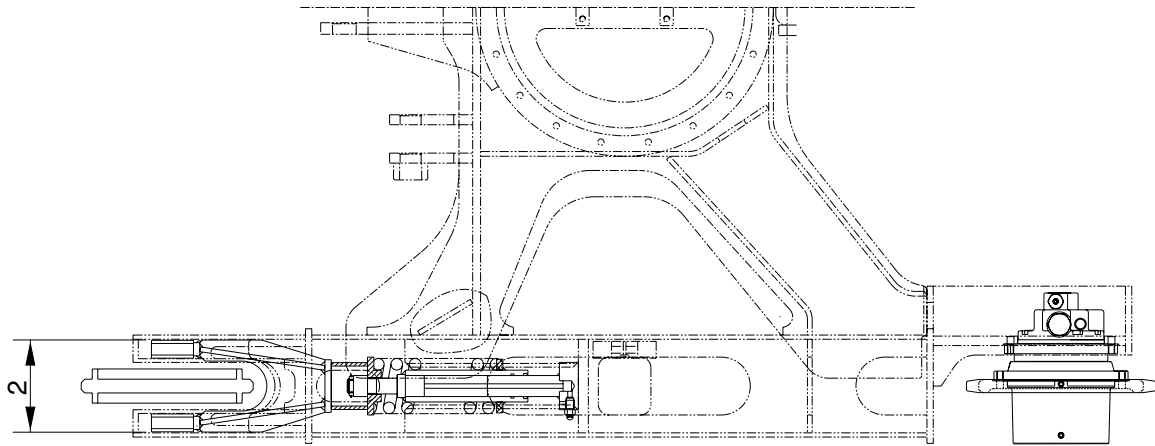

R35Z76MC21

Unit : mm

No	Check item	Criteria			Remedy		
			Standard size	Repair limit			
1	Vertical width of idler guide	Track frame	125	129	Rebuild		
		Idler support	124	128	Rebuild or replace		
2	Horizontal width of idler guide	Track frame	178	182	Rebuild		
		Idler guide	174	178	Rebuild or replace		
3	Recoil spring	Standard size		Repair limit		Replace	
		Free length	Installed length	Installed load	Free length		Installed load
		286.5	233.5	2,698 kg	-		2,158 kg

6. SPROCKET

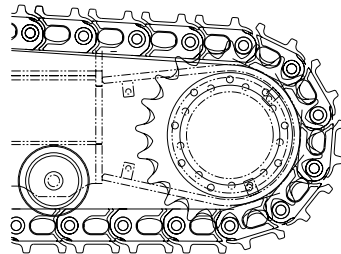
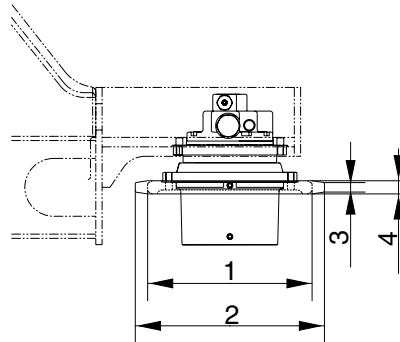

R35Z76MC22

Unit : mm

No	Check item	Criteria		Remedy
		Standard size	Repair limit	
1	Wear out of sprocket tooth lower side diameter	313.72	304.72	Repair or Replace
2	Wear out of sprocket tooth upper side diameter	359.75	-	
3	Wear out of sprocket tooth upper side width	18	-	
4	Wear out of sprocket tooth lower side width	25	17	

7. WORK EQUIPMENT

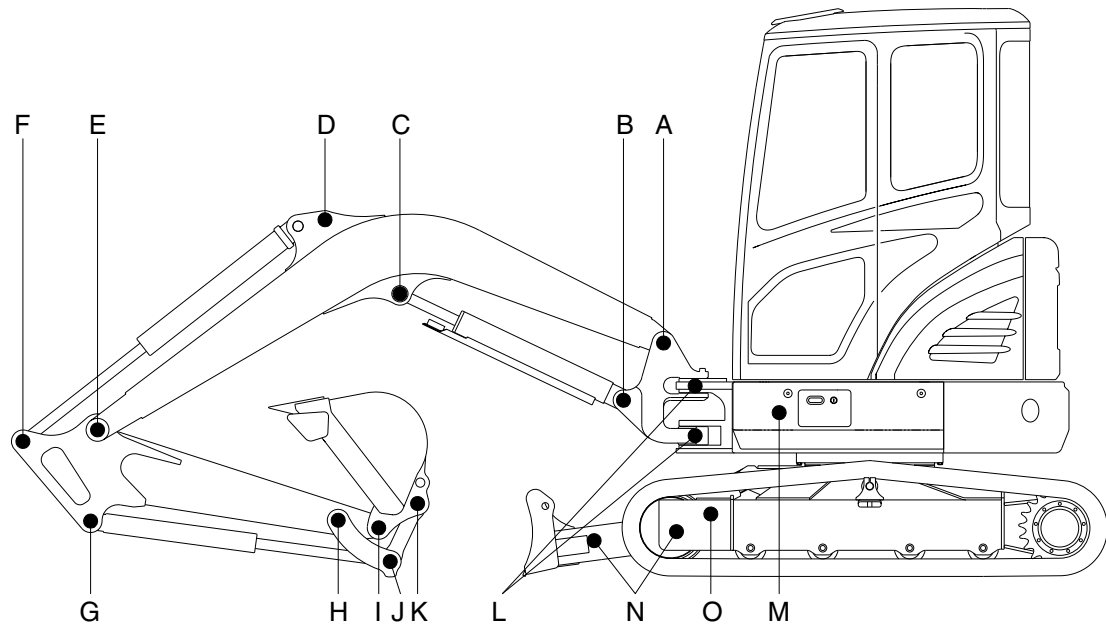

R35Z76MC30

Unit : mm

Mark	Measuring point (Pin and Bushing)	Normal value	Pin		Bushing		Remedy & Remark
			Recomm. service limit	Limit of use	Recomm. service limit	Limit of use	
A	Boom Rear	50	49	48.5	50.5	51	Replace
B	Boom Cylinder Head	45	44	43.5	45.5	46	"
C	Boom Cylinder Rod	45	44	43.5	45.5	46	"
D	Arm Cylinder Head	45	44	43.5	45.5	46	"
E	Boom Front	45	44	43.5	45.5	46	"
F	Arm Cylinder Rod	45	44	43.5	45.5	46	"
G	Bucket Cylinder Head	40	39	38.5	40.5	41	"
H	Arm Link	40	39	38.5	40.5	41	"
I	Bucket and Arm Link	40	39	38.5	40.5	41	"
J	Bucket Cylinder Rod	40	39	38.5	40.5	41	"
K	Bucket Link	40	39	38.5	40.5	41	"
L	Boom swing post	70	69	68.5	70.5	71	"
M	Boom swing cylinder	45	44	43.5	45.5	46	"
N	Blade cylinder	45	44	43.5	45.5	46	"
O	Blade and frame link	40	39	38.5	40.5	41	"