

GROUP 2 MONITORING SYSTEM

1. OUTLINE

Monitoring system consists of the monitor part and switch part.

The monitor part gives warnings when any abnormality occurs in the machine and informs the condition of the machine.

Various select switches are built into the monitor panel, which act as the control portion of the machine control system.

2. CLUSTER

1) MONITOR PANEL

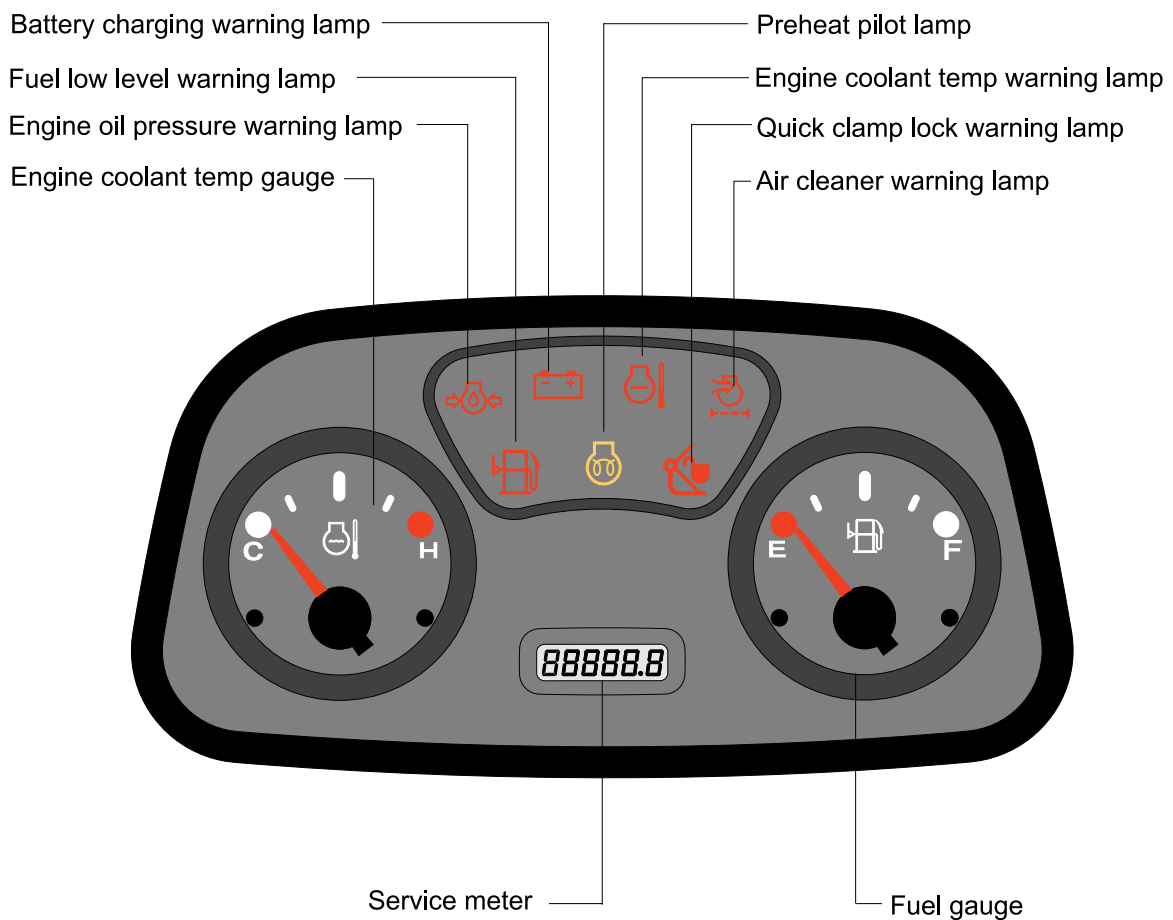

R35Z73CD01

2) CLUSTER CHECK PROCEDURE

(1) Start key : ON

- ① Check monitor initial 6 seconds
 - a. All lamps light up.
- ② Check monitor after 3 seconds : Indicate machine condition
 - a. Tachometer : 0 rpm
 - b. Fuel gauge : Pointed at appropriate level
 - c. Engine coolant temperature gauge : Pointed at appropriate level
 - d. Warning lamp
 - ※ During start key **ON** the engine oil pressure lamp and battery charging lamp go on, but it is not abnormal.

(2) Start of engine

- ① Check machine condition
 - a. Tachometer pointed at present rpm
 - b. Gauge and warning lamp : Indicate at present condition.
 - ※ When normal condition : All warning lamp OFF
- ② When abnormal condition
 - a. The lamp lights up.
 - b. The lamp light up until normal condition.

3. CLUSTER CONNECTOR

1) CONNECTOR

CN-56

POWER IG 12V	1	○
LAMP, ENG OIL PRESSURE	2	○
LAMP, CHARGE	3	○
LAMP, WATER TEMP	4	○
LAMP, AIR-CLEANER	5	○
LAMP, FUEL EMPTY	6	○
LAMP, AIR-HEATER	7	○
LAMP, QUICK CLAMP	8	○
LAMP, ILLUMINATION	9	○
GAUGE, WATER TEMP	10	○
GAUGE, FUEL LEVEL	11	○
RETURN, AIR-HEATER	12	○
BUZZER(+)	13	○
NC	14	○
EARTH	15	○
NC	16	○
NC	17	○
HOURMETER(B +)	1	○
HOURMETER(SIG +)	2	○
HOURMETER(-)	3	○

CN-48

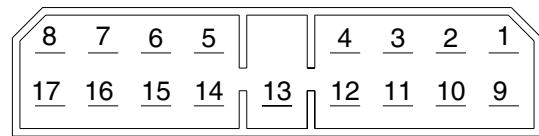

CN-56

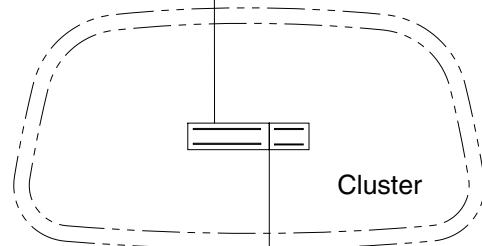

2) CLUSTER DETAIL

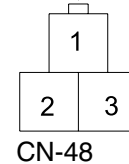
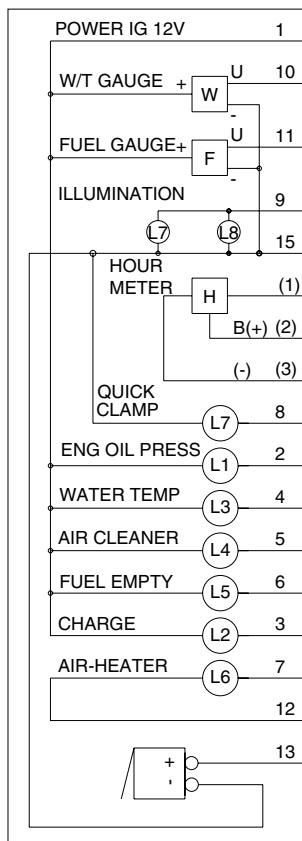

CN-48

R35Z74EL23

4. CLUSTER FUNCTION

1) GAUGES AND DISPLAYS



(1) Service meter

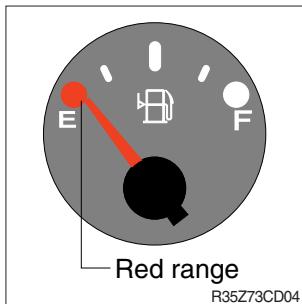

- ① This meter shows the total operation hours of the machine.
- ② Always ensure the operating condition of the meter during the machine operation.
Inspect and service the machine based on hours as indicated in chapter 6, **maintenance**.

(2) Fuel gauge



- ① This gauge indicates the amount of fuel in the fuel tank.
- ② Fill the fuel when the red range or warning lamp  ON.
※ If the gauge illuminates the red range or warning lamp  ON even though the machine is on the normal condition, check the electric device as that can be caused by the poor connection of electricity or sensor.

(3) Engine coolant temperature gauge

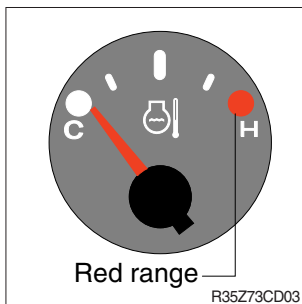

- ① This indicates the temperature of coolant.
 - Red range : Above 105°C (221°F)
- ② When the red range pointed or warning lamp  ON, engine do not abruptly stop but run it at medium speed to allow it to cool gradually, then stop it.
Check the radiator and engine.
※ If the engine is stopped without cooled down running, the temperature of engine parts will rise suddenly, this could cause severe engine trouble.

2) WARNING AND PILOT LAMPS

(1) Fuel low level warning lamp

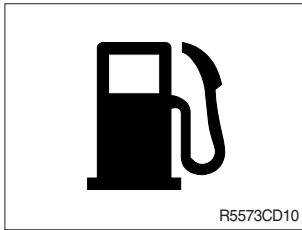

- ① This lamp blinks when the level of fuel is below 8.5 l (2.2U.S. gal).
- ② Fill the fuel immediately when the lamp blinks.

(2) Engine coolant temperature warning lamp

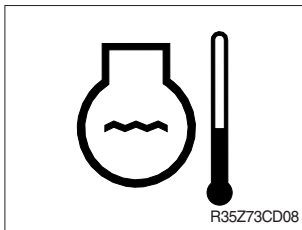

- ① This lamp blinks when the temperature of coolant is over the normal temperature 110°C (230°F) .
- ② Check the cooling system when the lamp blinks.

(3) Engine oil pressure warning lamp

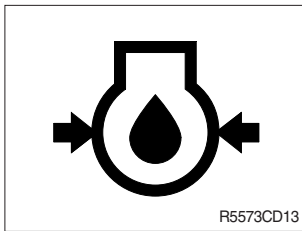

- ① This lamp blinks after starting the engine because of the low oil pressure.
- ② If the lamp blinks during engine operation, shut OFF engine immediately. Check oil level.

(4) Air cleaner warning lamp

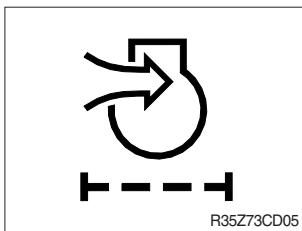

- ① This lamp blinks when the filter of air cleaner is clogged.
- ② Check the filter and clean or replace it.

(5) Battery charging warning lamp

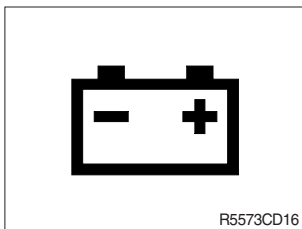

- ① This lamp blinks when the starting switch is ON, it is turned OFF after starting the engine.
- ② Check the battery charging circuit when this lamp blinks during engine operation.

(6) Preheat pilot lamp

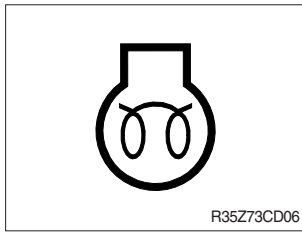

- ① When the start switch turn to HEAT position, pilot lamp comes ON.
- ② Refer to "4-2) STARTING ENGINE" of operator's manual for details.

(7) Quick clamp warning lamp

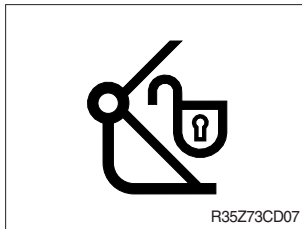

- ① When the quick clamp switch turned ON, this lamp turn ON and the buzzer sounds.
- ② This lamp turned OFF and the buzzer stop when the quick clamp switch turned OFF.



1. POWER CIRCUIT

The negative terminal of battery is grounded to the machine chassis.

When the start switch is in the OFF position, the current flows from the positive battery terminal as shown below.

1) OPERATING FLOW

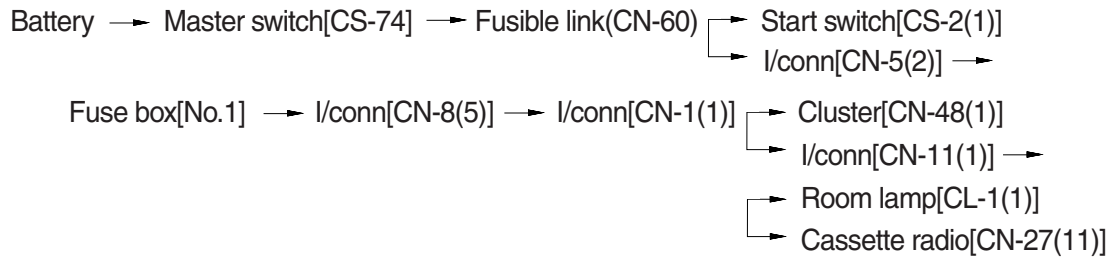

※ I/conn : Intermediate connector

2) CHECK POINT

Engine	Start switch	Check point	Voltage
OFF	OFF	① - GND (Battery) ② - GND (Master switch) ③ - GND (Fusible link)	10~12.5V

※ GND : Ground

POWER CIRCUIT

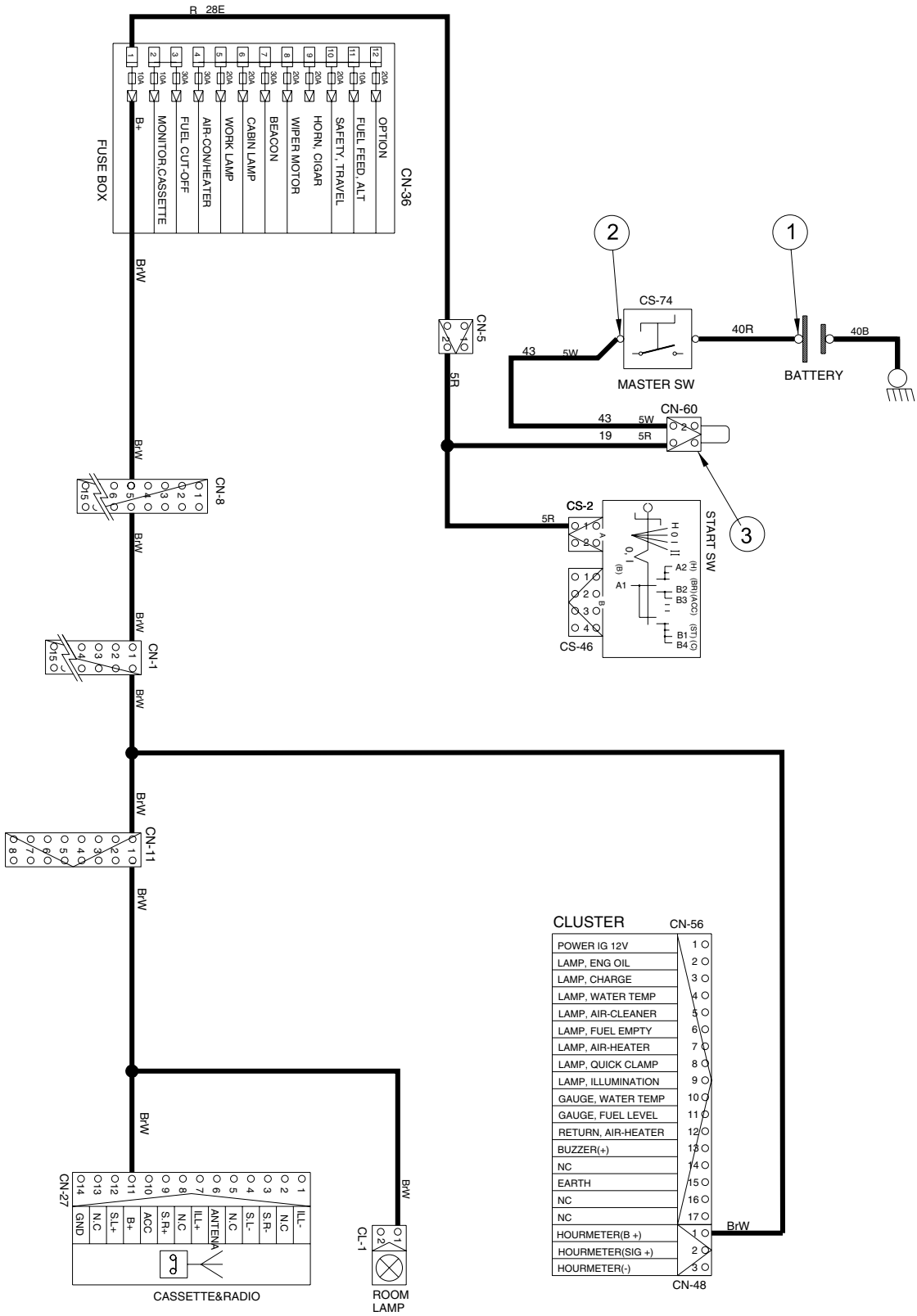

2. STARTING CIRCUIT

1) OPERATING FLOW

Battery(+) terminal → Master switch[CS-74] → Fusible link[CN-60]

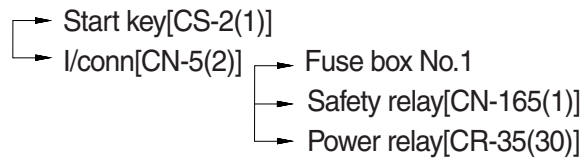

※ Start switch : ON

Start switch ON [CS-46(2,3)] → I/conn [CN-7(1)]

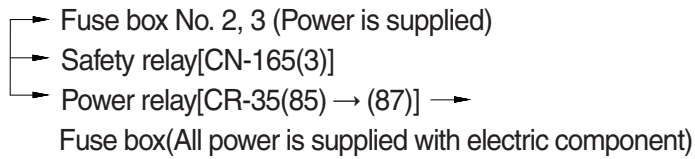

※ Start switch : START

Start switch START [CS-46(4)] → I/conn [CN-6(7)]

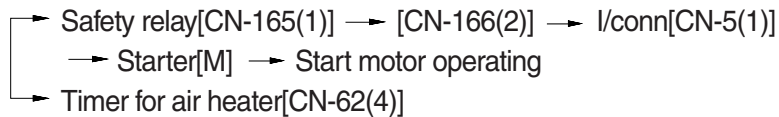

2) CHECK POINT

Engine	Start switch	Check point	Voltage
Operating	Start	① - GND (Battery) ② - GND (Start key) ③ - GND (Starter B+) ④ - GND (Starter M)	10 ~ 12.5V

※ GND : Ground

STARTING CIRCUIT

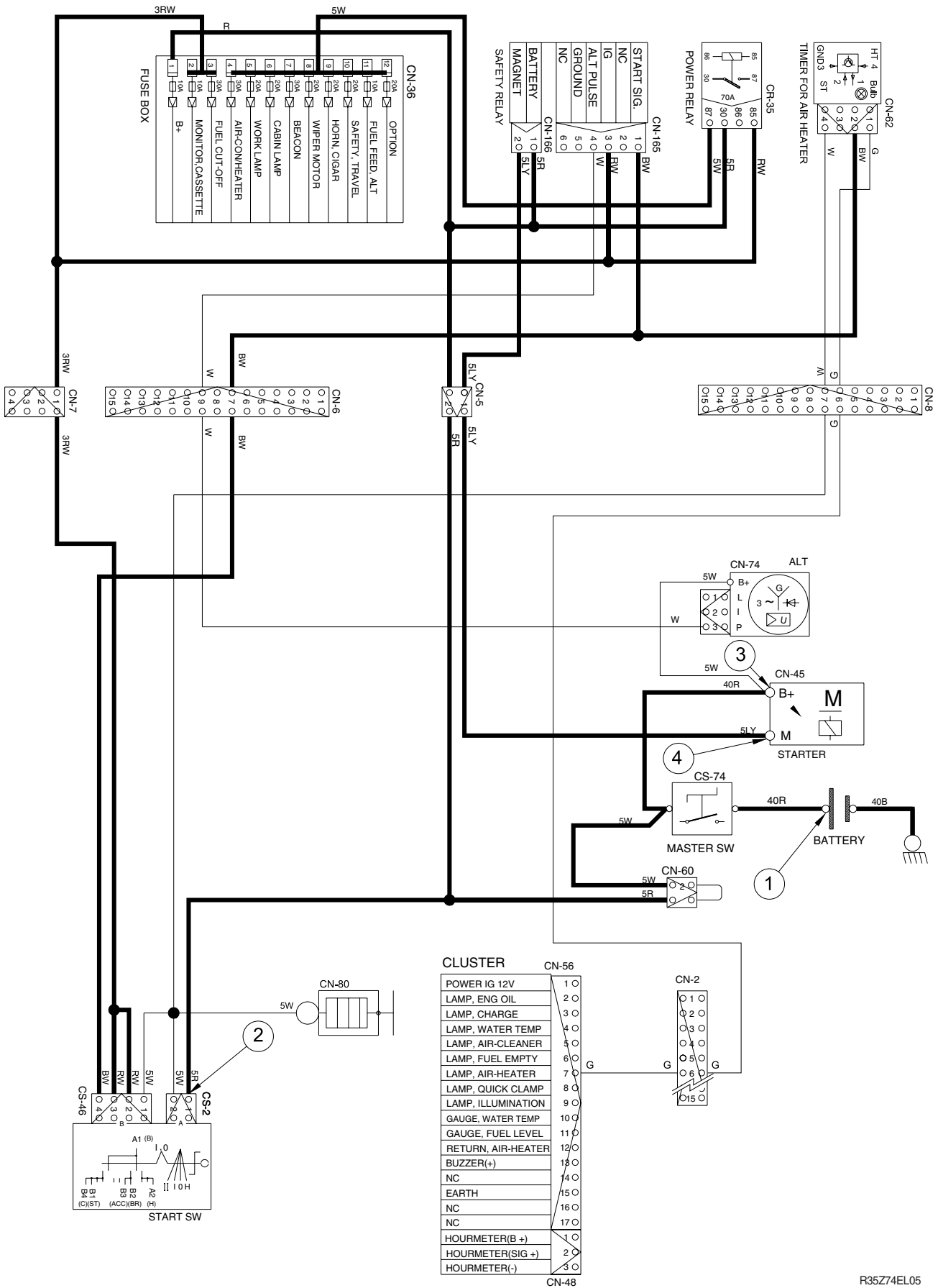

R35Z74EL05

3. CHARGING CIRCUIT

When the starter is activated and the engine is started, the operator releases the key switch to the ON position.

Charging current generated by operating alternator flows into the battery through the battery relay(CR-1).

The current also flows from alternator to each electrical component and controller through the fuse box.

1) OPERATING FLOW

(1) Warning flow

Alternator "L" terminal → I/conn [CN-2(13)] → Cluster [CN-56(3)] → Cluster warning lamp

(2) Charging flow

Alternator "B+" terminal → Battery(+) terminal

2) CHECK POINT

Engine	Start switch	Check point	Voltage
ON	ON	① - GND (Battery voltage) ② - GND (Alternator B+ terminal) ③ - GND (Cluster)	10~12.5V

※ GND : Ground

CHARGING CIRCUIT

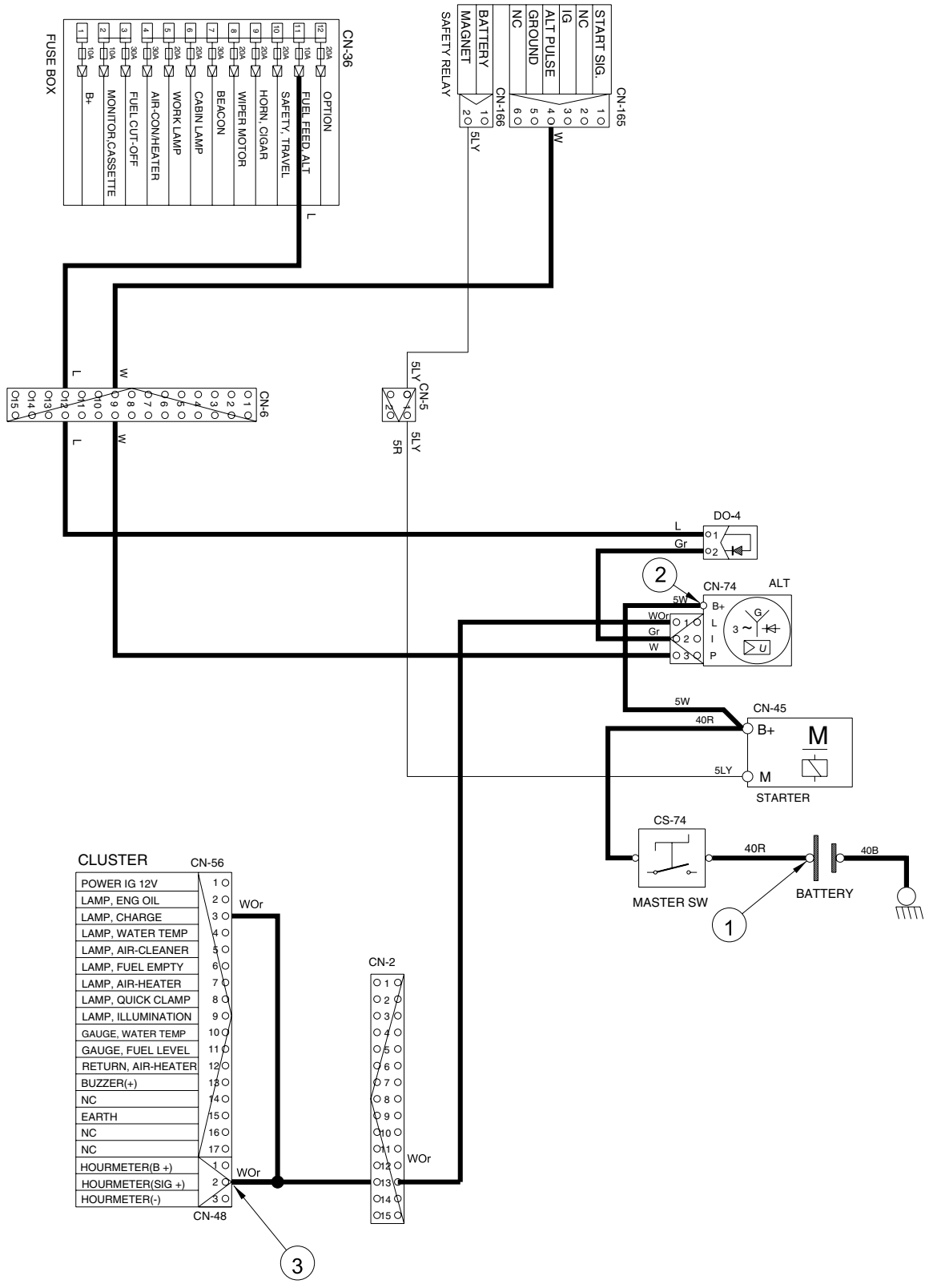

4. HEAD AND WORK LIGHT CIRCUIT

1) OPERATING FLOW

Fuse box (No.6) → Light switch[CS-21(1)]

Fuse box (No.5) → Light switch[CS-21(4)]

(1) Main light switch ON : 1st step

Cabin light switch ON [CS-21(5,7)] → I/conn[CN-3(2)] → I/conn[CN-2(8)]

→ Cluster illumination ON [CN-56(9)]

→ Cigar light illumination ON [CL-2]

→ I/conn[CN-11(3)] → Cabin Lamp ON[CL-9,10(2)]

→ Cassette radio illumination ON [CN-27(7)]

(2) Main light switch ON : 2nd step

Work light switch ON [CS-21(2)] → I/conn[CN-3(14)] → I/conn[CN-12(2)]

→ Work light ON [CL-5(2)]

2) CHECK POINT

Engine	Start switch	Check point	Voltage
STOP	ON	① - GND(Fuse box) ② - GND(Switch power input) ③ - GND(Switch power output) ④ - GND(Head light)	10~12.5V
STOP	ON	⑤ - GND(Fuse box) ⑥ - GND(Switch power input) ⑦ - GND(Switch power output) ⑧ - GND(Work light)	10~12.5V

※ GND : Ground

HEAD AND WORK LAMP CIRCUIT

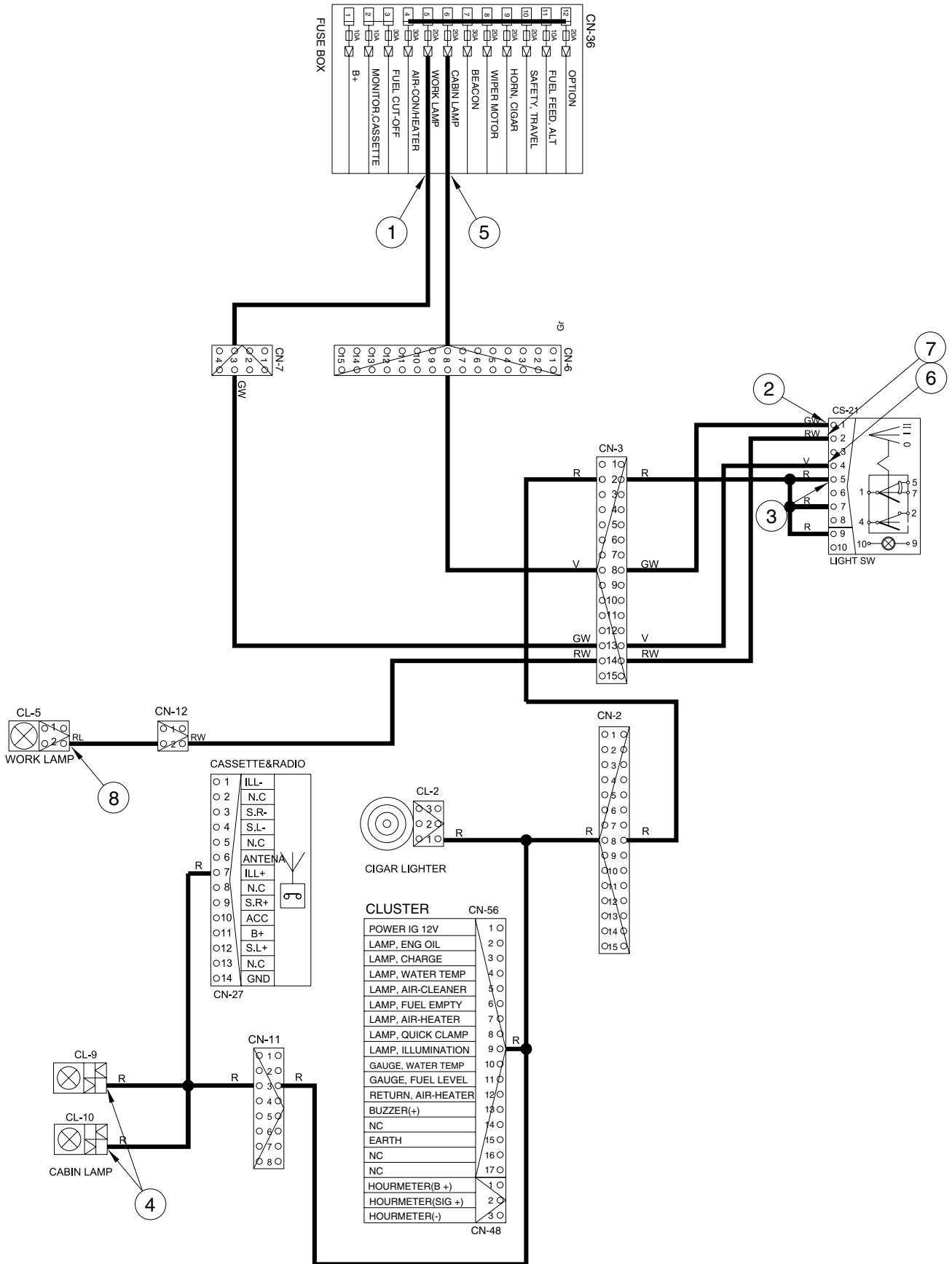

R35Z74EL07

5. BEACON LAMP CIRCUIT

1) OPERATING FLOW

Fuse box (No.19) → I/conn[CN-6(15)] → Beacon lamp switch[CN-23(5)]

(1) Beacon lamp switch ON

Beacon lamp switch ON [CS-23(1)]

→ Switch Indicator lamp ON [CS-23(9)]

→ I/conn[CN-3(1)] → I/conn[CN-1(5)] → I/conn[CN-11(8)] → Beacon lamp ON [CL-7]

2) CHECK POINT

Engine	Start switch	Check point	Voltage
STOP	ON	① - GND(Fuse box) ② - GND(Switch power input) ③ - GND(Switch power output) ④ - GND(Beacon lamp)	10~12.5V

※ GND : Ground

BEACON LAMP CIRCUIT

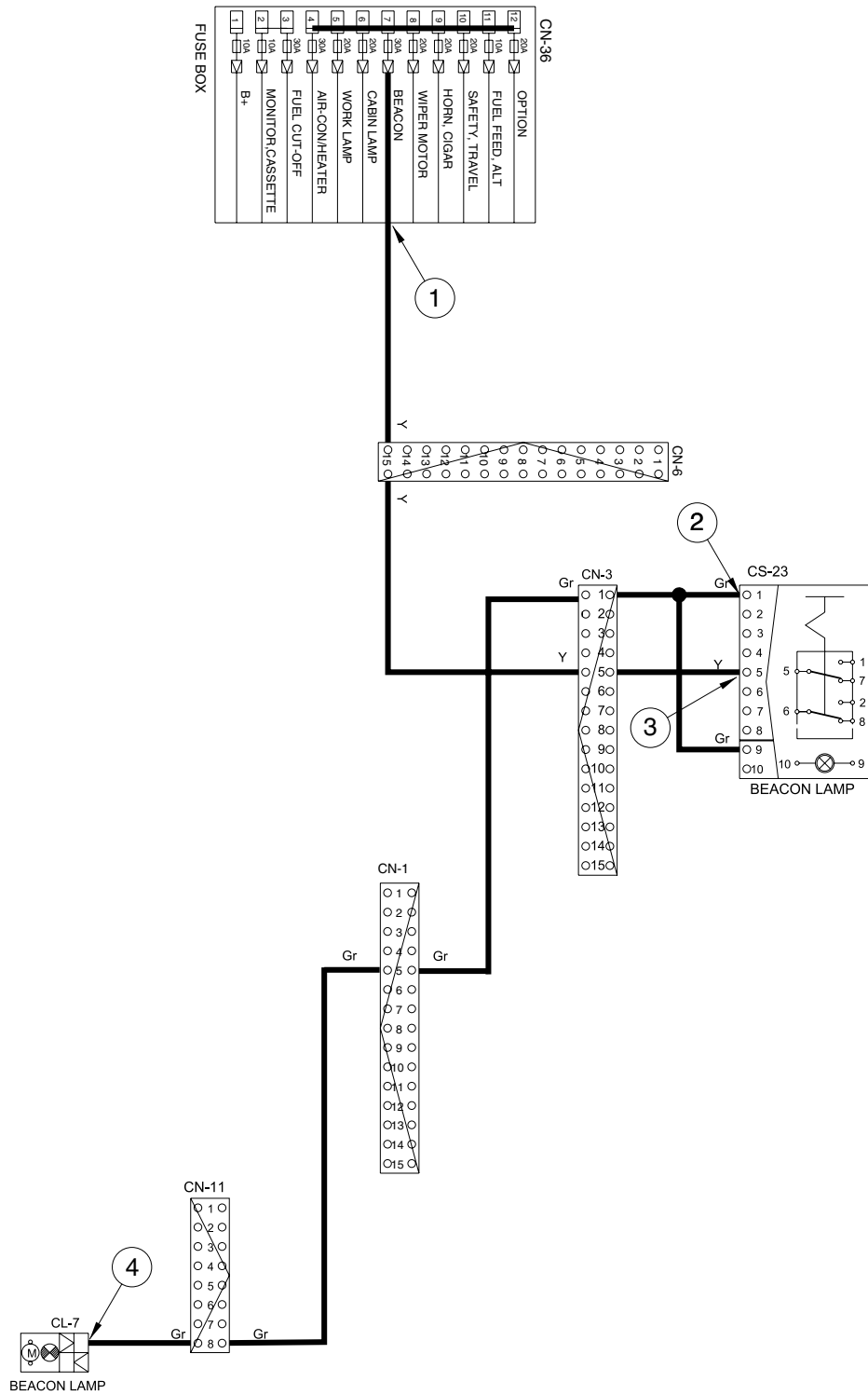

R35Z74EL08

6. WIPER AND WASHER CIRCUIT

1) OPERATING FLOW

(1) Key switch ON

Fuse box (No.7) → I/conn[CN-8(1)] → I/conn[CN-8(1)] → Wiper and washer switch[CS-3(1)]
 → Wiper motor[CN-21(3)]

(2) Wiper switch ON : 1st step(Low speed)

Wiper switch ON [CS-3(6)] → Wiper motor operating[CN-21(4)]

(3) Wiper switch ON : 2nd step(Washer)

Wiper switch ON [CS-3(6)] → Wiper motor operating[CN-21(4)]

Wiper switch ON [CS-3(3)] → I/conn[CN-4(3)] → I/conn[CN-3(3)] → Washer pump operating[CN-22(2)]

(4) Auto parking(When switch OFF)

Switch OFF → Wiper motor[CN-21(1)] → Wiper switch[CS-3(8)→(6)] → Wiper motor[CN-21(4)]
 → Wiper motor parking position by wiper motor controller

2) CHECK POINT

Engine	Start switch	Check point	Voltage
STOP	ON	① - GND(Fuse box) ② - GND(Switch power input) ③ - GND(Switch power output) ④ - GND(Wiper motor)	10~12.5V

※ GND : Ground

WASHER CONTROL CIRCUIT

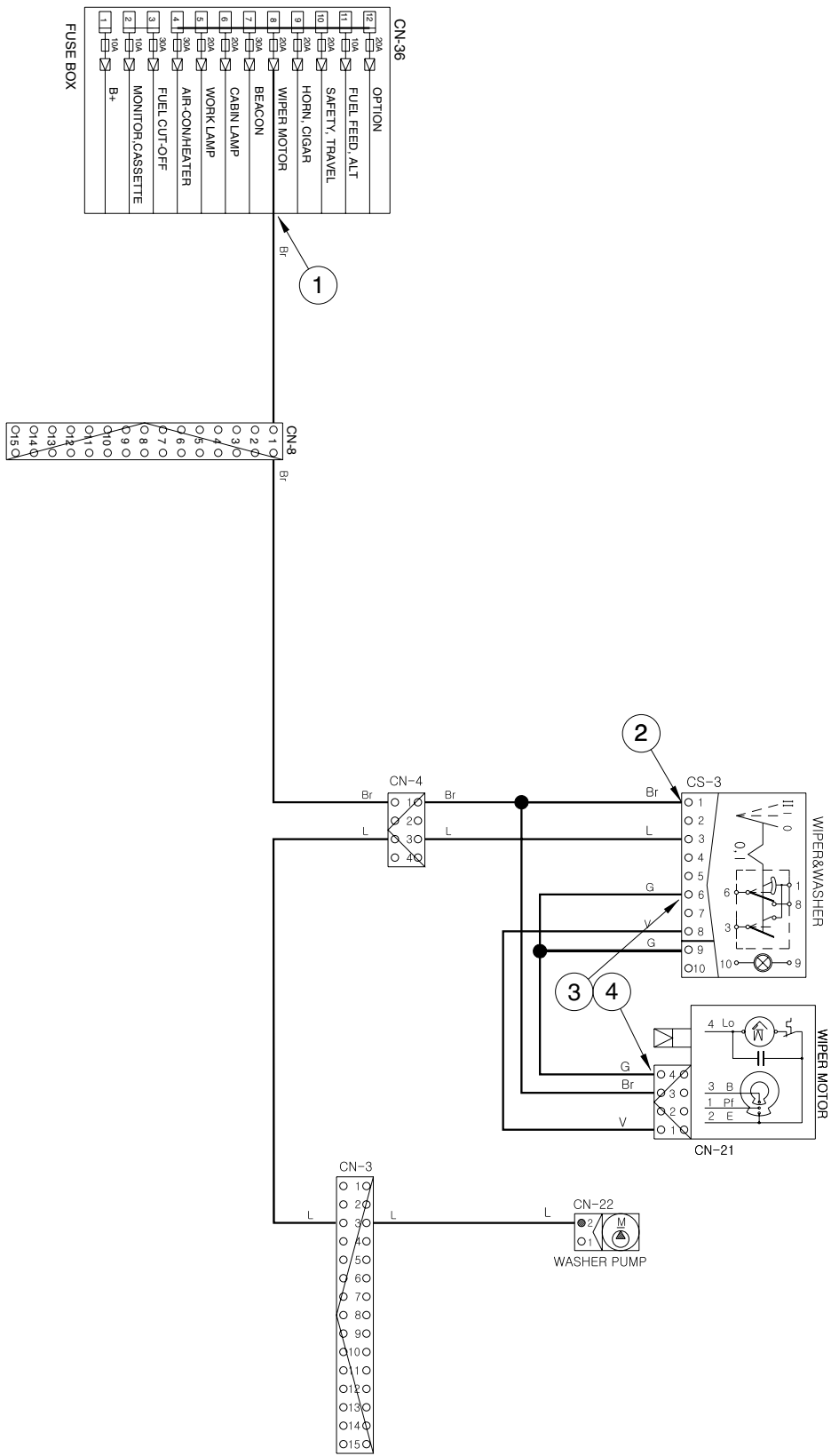

R35Z74EL09

MONITORING CIRCUIT

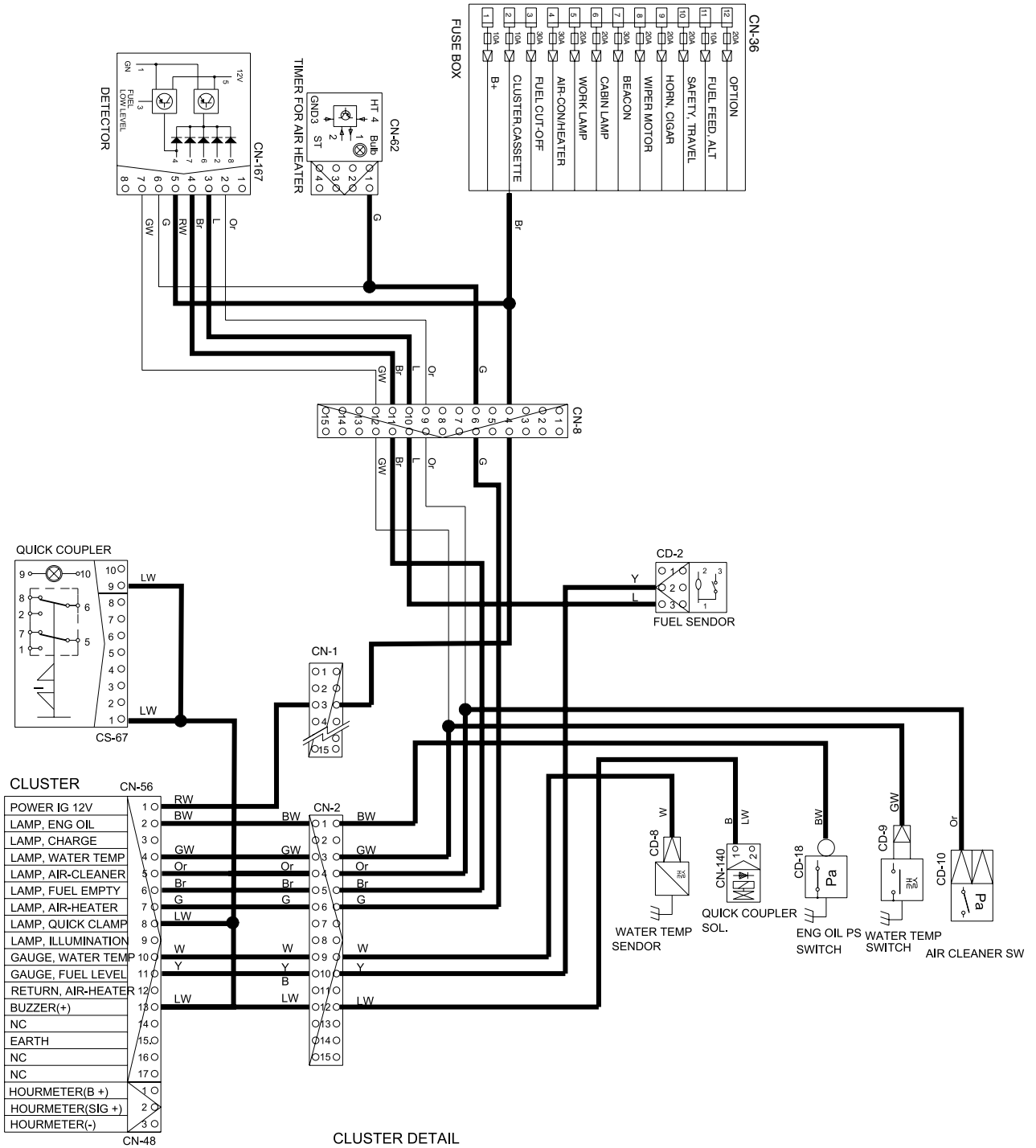

R35Z74EL10

ELECTRIC CIRCUIT FOR HYDRAULIC

