

GROUP 4 MAIN CONTROL VALVE

1. REMOVAL AND INSTALL OF MOTOR

1) REMOVAL

- (1) Lower the work equipment to the ground and stop the engine.
- (2) Operate the control levers and pedals several times to release the remaining pressure in the hydraulic piping.
- (3) Loosen the breather slowly to release the pressure inside the hydraulic tank.
- ▲ Escaping fluid under pressure can penetrate the skin causing serious injury.
- ※ When pipes and hoses are disconnected, the oil inside the piping will flow out, so catch it in oil pan.
- (4) Disconnect hydraulic hose.
- (5) Disconnect pilot line hoses.
- (6) Sling the control valve assembly and remove the control valve mounting bolt.
 - Weight : 25kg(55lb)
- (7) Remove the control valve assembly.
When removing the control valve assembly, check that all the piping have been disconnected.

2) INSTALL

- (1) Carry out installation in the reverse order to removal.
- (2) Bleed the air from below items.
 - ① Cylinder(Boom, arm, bucket)
 - ② Swing motor
 - ③ Travel motor
- ※ See each item removal and install.
- (3) Confirm the hydraulic oil level and recheck the hydraulic oil leak or not.

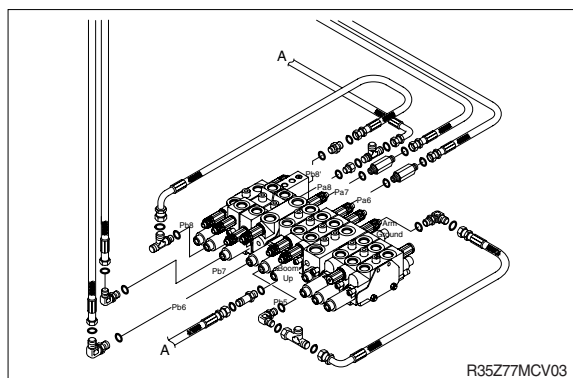
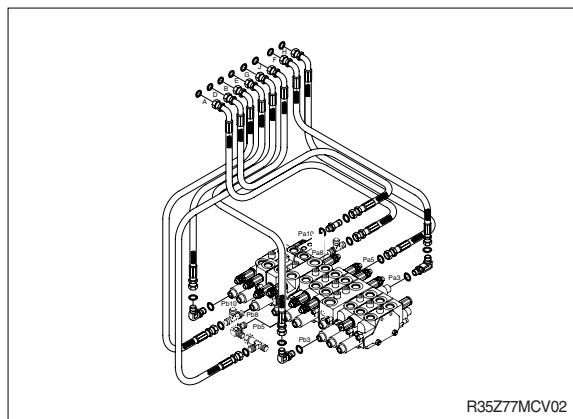
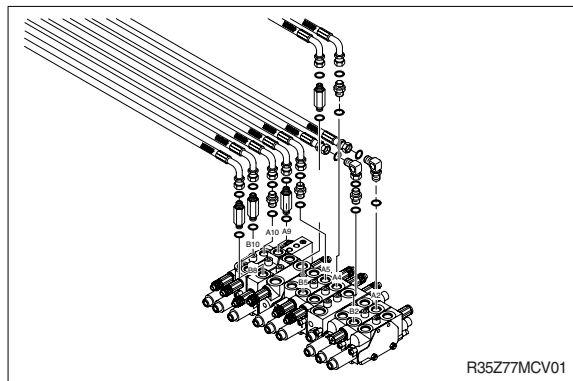

2. STRUCTURE(1/3)

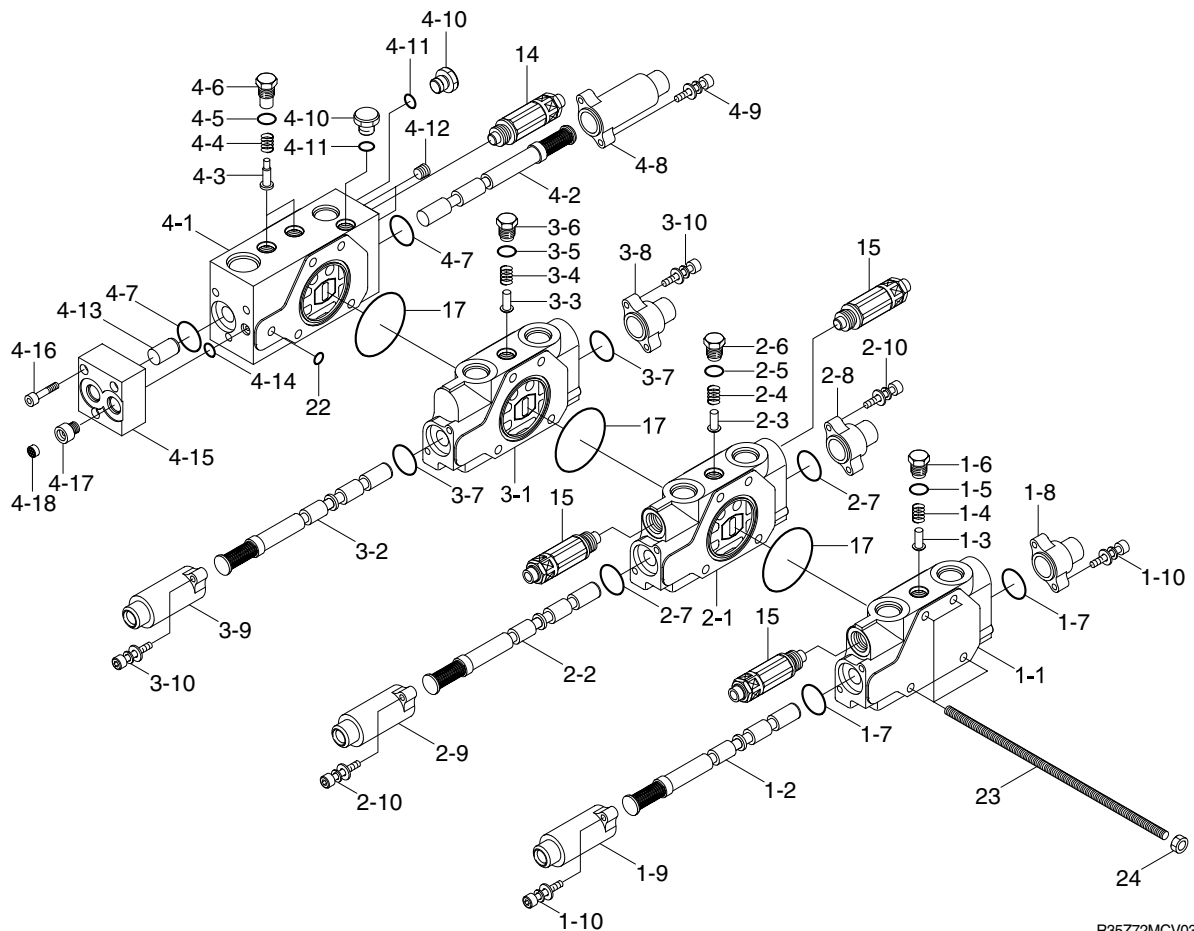

R35Z72MCV03

| | | | | | |
|------|------------------------|------|------------------------|------|------------------------|
| 1 | Dozer work block | 2-9 | Cover-pilot | 4-6 | Plug |
| 1-1 | Body-work | 2-10 | Bolt-soc head w/washer | 4-7 | O-ring |
| 1-2 | Spool assy | 3 | Swing work block | 4-8 | Cover-pilot |
| 1-3 | Poppet | 3-1 | Body-work | 4-9 | Bolt-soc head w/washer |
| 1-4 | Spring | 3-2 | Spool assy | 4-10 | Plug |
| 1-5 | O-ring | 3-3 | Poppet | 4-11 | O-ring |
| 1-6 | Plug | 3-4 | Spring | 4-12 | Plug |
| 1-7 | O-ring | 3-5 | O-ring | 4-13 | Piston |
| 1-8 | Cover-pilot | 3-6 | Plug | 4-14 | O-ring |
| 1-9 | Cover-pilot | 3-7 | O-ring | 4-15 | Body-pilot |
| 1-10 | Bolt-soc head w/washer | 3-8 | Cover-pilot | 4-16 | Bolt-soc head w/washer |
| 2 | Boom swing work block | 3-9 | Cover-pilot | 4-17 | Orifice |
| 2-1 | Body-work | 3-10 | Bolt-soc head w/washer | 4-18 | Filter-coin type |
| 2-2 | Spool assy | 4 | Connecting block | 14 | Relief valve |
| 2-3 | Poppet | 4-1 | Body-work | 15 | Overload relief valve |
| 2-4 | Spring | 4-2 | Spool assy | 17 | O-ring |
| 2-5 | O-ring | 4-3 | Poppet | 22 | O-ring |
| 2-6 | Plug | 4-4 | Spring | 23 | Bolt-tie |
| 2-7 | O-ring | 4-5 | O-ring | 24 | Nut-hex |
| 2-8 | Cover-pilot | | | | |

STRUCTURE(2/3)

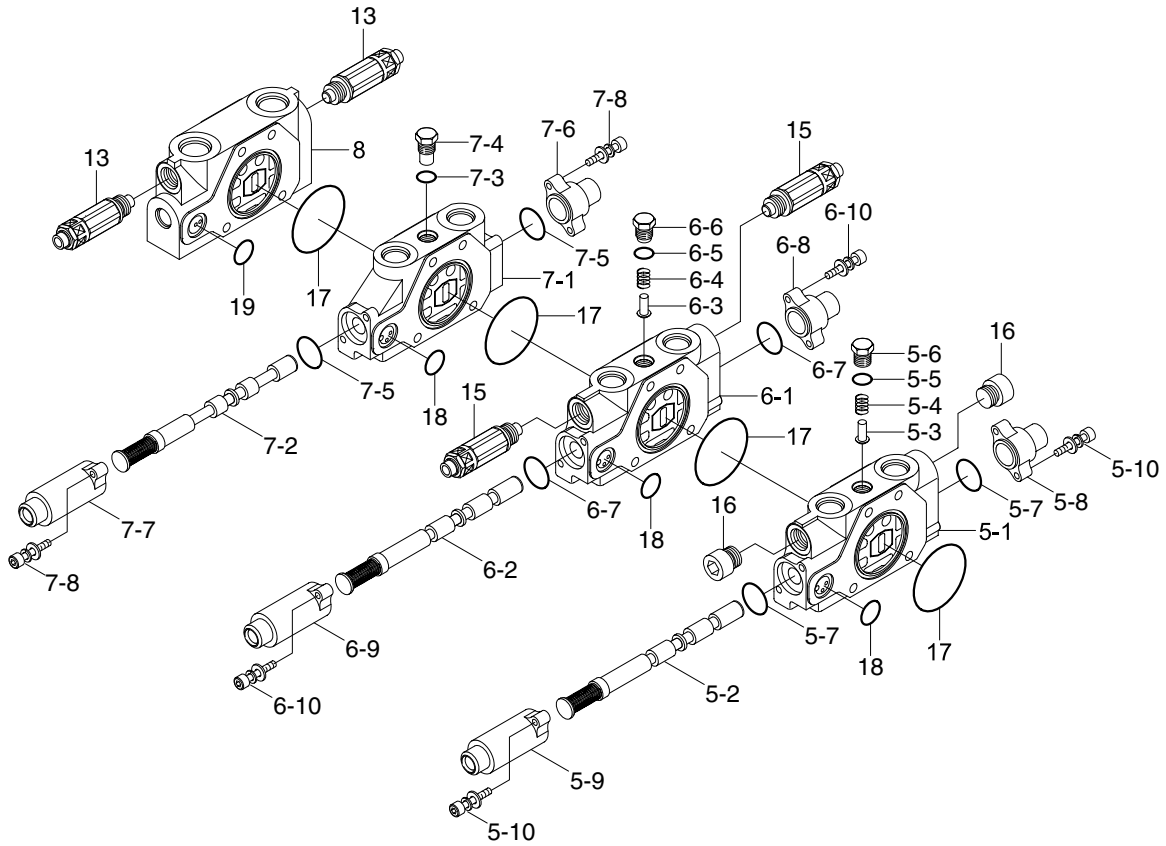

R35Z72MCV04

| | | | | | |
|------|------------------------|------|------------------------|-----|------------------------|
| 5 | PTO work block | 6-2 | Spool assy | 7-4 | Plug |
| 5-1 | Body-work | 6-3 | Poppet | 7-5 | O-ring |
| 5-2 | Spool assy | 6-4 | Spring | 7-6 | Cover-pilot |
| 5-3 | Poppet | 6-5 | O-ring | 7-7 | Cover-pilot |
| 5-4 | Spring | 6-6 | Plug | 7-8 | Bolt-soc head w/washer |
| 5-5 | O-ring | 6-7 | O-ring | 8 | Inlet work block |
| 5-6 | Plug | 6-8 | Cover-pilot | 13 | Relief valve |
| 5-7 | O-ring | 6-9 | Cover-pilot | 15 | Overload relief valve |
| 5-8 | Cover-pilot | 6-10 | Bolt-soc head w/washer | 16 | Plug |
| 5-9 | Cover-pilot | 7 | Travel work block | 17 | O-ring |
| 5-10 | Bolt-soc head w/washer | 7-1 | Body work | 18 | O-ring |
| 6 | Arm work block | 7-2 | Spool assy | 19 | O-ring |
| 6-1 | Body-work | 7-3 | O-ring | | |

STRUCTURE(3/3)

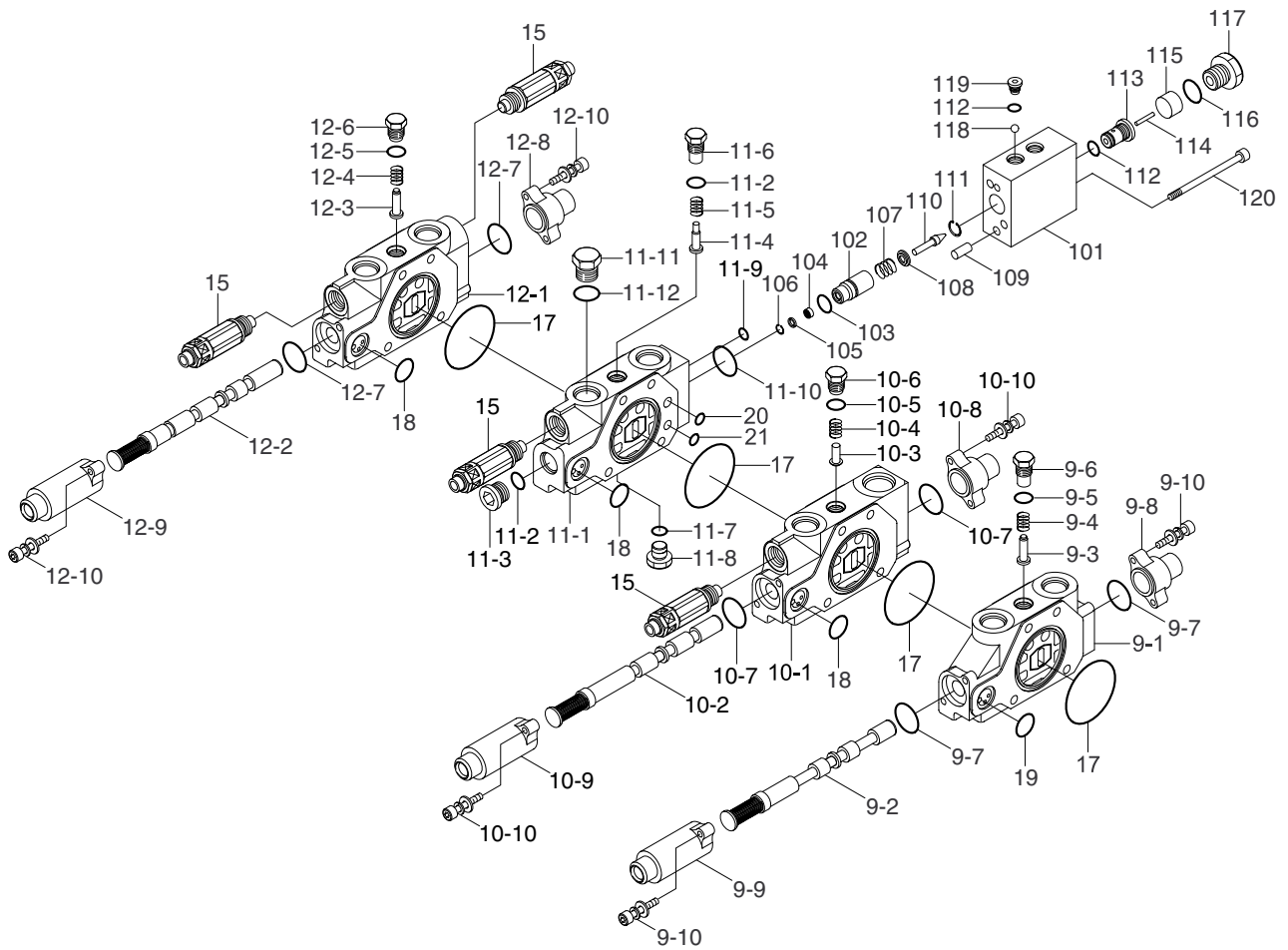

R35Z72MCV05

| | | | | | | | |
|------|------------------------|-------|------------------------|-------|------------------------|-----|-----------------------|
| 9 | Travel work block | 10-7 | O-ring | 12-1 | Body-work | 103 | Seal |
| 9-1 | Body-work | 10-8 | Cover-pilot | 12-2 | Spool assy | 104 | Filter |
| 9-2 | Spool assy | 10-9 | Cover-pilot | 12-3 | Poppet | 105 | Spacer |
| 9-3 | Poppet | 10-10 | Bolt-soc head w/washer | 12-4 | Spring | 106 | Ring-retaining |
| 9-4 | Spring | 11 | Boom lock valve | 12-5 | O-ring | 107 | Spring A-lock valve |
| 9-5 | O-ring | 11-1 | Body-work | 12-6 | Plug | 108 | Spring seat |
| 9-6 | Plug | 11-2 | O-ring | 12-7 | O-ring | 109 | Pin |
| 9-7 | O-ring | 11-3 | Plug | 12-8 | Cover-pilot | 110 | Poppet |
| 9-8 | Cover-pilot | 11-4 | Poppet | 12-9 | Cover-pilot | 111 | Ring-retaining |
| 9-9 | Cover-pilot | 11-5 | Spring | 12-10 | Bolt-soc head w/washer | 112 | O-ring |
| 9-10 | Bolt-soc head w/washer | 11-6 | Plug | 15 | Overload relief valve | 113 | Guide-piston |
| 10 | Boom work block | 11-7 | O-ring | 17 | O-ring | 114 | Piston A1 |
| 10-1 | Body-work | 11-8 | Plug | 18 | O-ring | 115 | Piston B |
| 10-2 | Spool assy | 11-9 | O-ring | 19 | O-ring | 116 | O-ring |
| 10-3 | Poppet | 11-10 | O-ring | 20 | O-ring | 117 | Connector |
| 10-4 | Spring | 11-11 | Plug | 21 | O-ring | 118 | Ball-steel |
| 10-5 | O-ring | 11-12 | O-ring | 101 | Cover-lock valve | 119 | Plug |
| 10-6 | Plug | 12 | Bucket work block | 102 | Lock valve | 120 | Bolt-hex. socket head |

3. DISASSEMBLY AND ASSEMBLY

1) GENERAL PRECAUTIONS

- (1) All hydraulic components are manufactured to a high precision. Consequently, before disassembling and assembling them, it is essential to select an especially clean place.
- (2) In handling a control valve, pay full attention to prevent dust, sand, etc. from entering into it.
- (3) When a control valve is to be removed from the machine, apply caps and masking seals to all ports. Before disassembling the valve, recheck that these caps and masking seals are fitted completely, and then clean the outside of the assembly. Use a proper bench for working. Spread paper or a rubber mat on the bench, and disassemble the valve on it.
- (4) Support the body section carefully when carrying or transferring the control valve. Do not lift by the exposed spool, end cover section etc.
- (5) After disassembling and assembling of the component it is desired to carry out various tests (For the relief characteristics, leakage, flow resistance, etc.), but hydraulic test equipment is necessary for these tests. Therefore, even when its disassembling can be carried out technically, do not disassemble such components that cannot be tested, adjusted, and so on. Additionally one should always prepare clean cleaning oil, hydraulic oil, grease, etc. beforehand.

2) TOOLS

Before disassembling the control valve, prepare the following tools beforehand.

| Name of tool | Quantity | Size(mm) |
|----------------------------------|--------------|---------------------|
| Vice mounted on bench(Soft jaws) | 1 unit | |
| Hexagon wrench | Each 1 piece | 5, 6, 10, 12 and 14 |
| Socket wrench | Each 1 piece | 5 and 6 |
| Spanner | Each 1 piece | 13, 21 and 30 |
| Rod | 1 piece | Less than 10 × 250 |

3) DISASSEMBLY

(1) Disassembly of spools(Pilot type)

- ① Loosen hexagon socket head bolts(10) with washer.
(Hexagon wrench : 5mm)
 - ② Remove the pilot cover(8).
- ※ Pay attention not to lose the O-ring(7) under the pilot cover.
- ③ Remove the spool assembly(2) from the body by hand slightly.
- ※ When extracting each spool from its body, pay attention not to damage the body.
 - ※ When extracting each spool assembly, it must be extracted from spring side only.
 - ※ When any abnormal parts are found, replace it with completely new spool assembly.
 - ※ When disassembled, tag the components for identification so that they can be reassembled correctly.

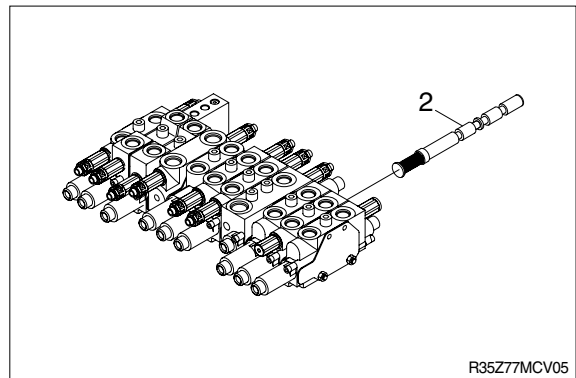
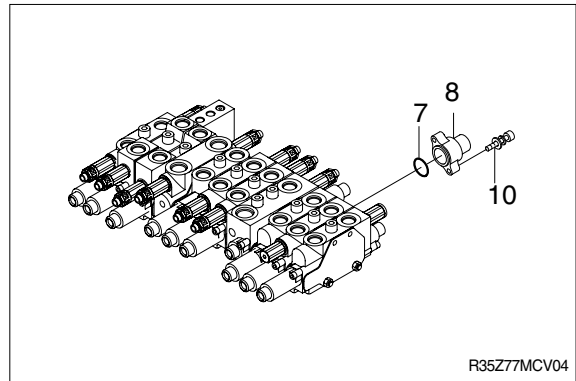

(2) Disassembly of holding valve(Boom 1)

- ① Loosen hexagon socket head bolts(120).
(Hexagon wrench : 5mm)
- ② Remove the holding valve.
 - ※ Pay attention not to lose the O-ring and the poppet under the pilot cover.
 - ※ Pay attention not to damage the "piston A" under pilot cover.
 - ※ When any abnormal parts are found, replace it with completely new holding valve assembly.
 - ※ When disassembled, tag the components for identification so that they can be reassembled correctly.

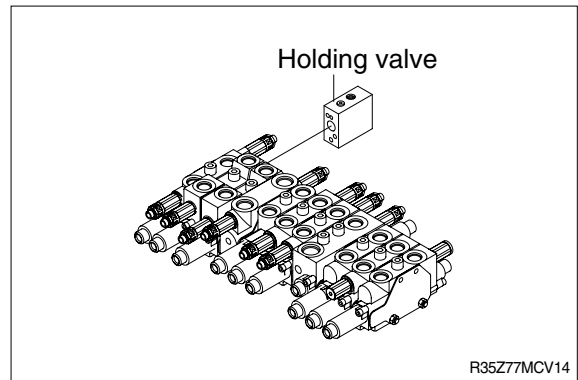
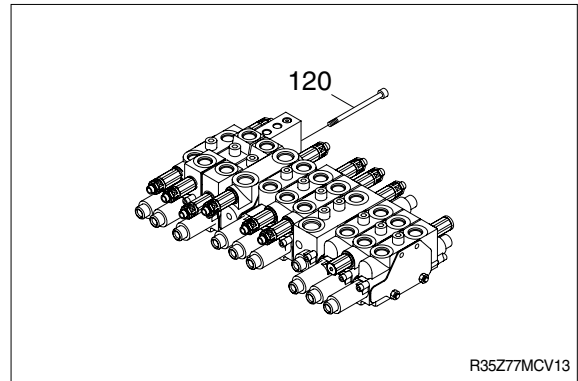

(3) Disassembly of the load check valve and the negative relief valve

① The load check valve

- a. Fix the body to suitable work bench.
 - ※ Pay attention not to damage the body.
- b. Loosen the plug(6)
(Hexagon wrench : 10mm).
- c. Remove the O-ring(5), spring(4) and the load check valve(3) with pincers or magnet.

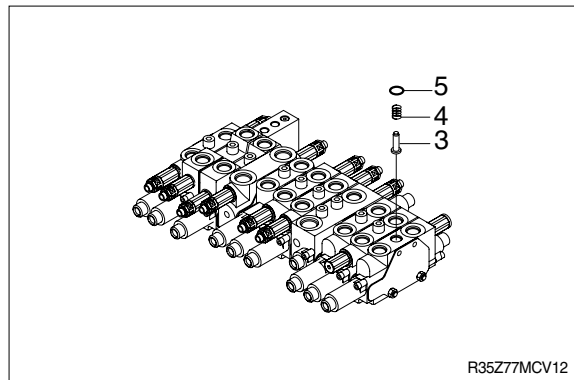
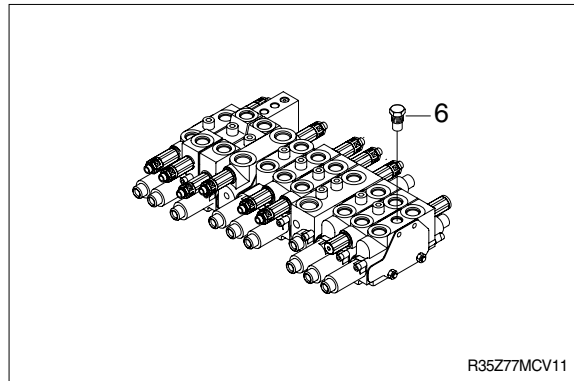

(4) Disassembly of the main and overload relief valve

- ① Fix the body to suitable work bench.
 - ② Remove the main relief valve(14).
(Spanner : 30mm)
 - ③ Remove the overload relief valve(15).
(Spanner : 22mm)
- ※ When disassembled, tag the relief valve for identification so that they can be reassembled correctly.
 - ※ Pay attention not to damage seat face.
 - ※ When any abnormal parts are found, replace it with completely new relief valve assembly.

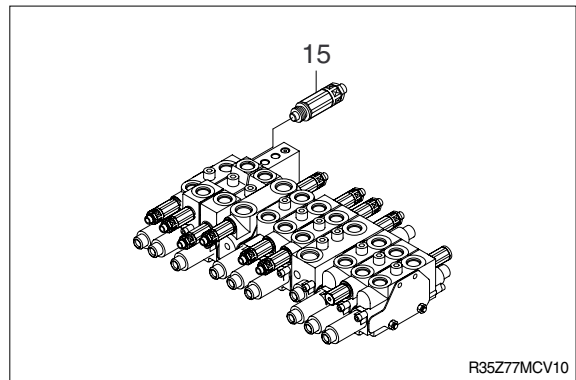
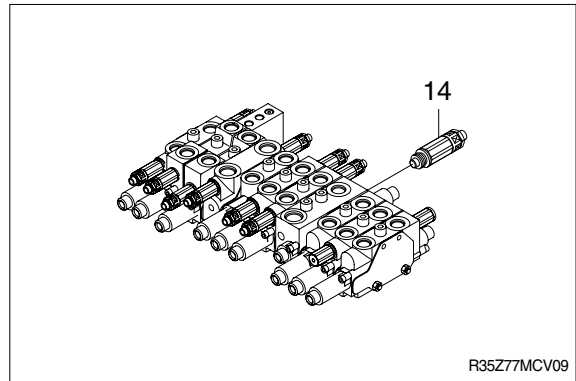

(5) Disassembly of the block assembly

- ① Fix the body to suitable work bench.
- ② Remove the nut(24).
(Spanner : 13mm)

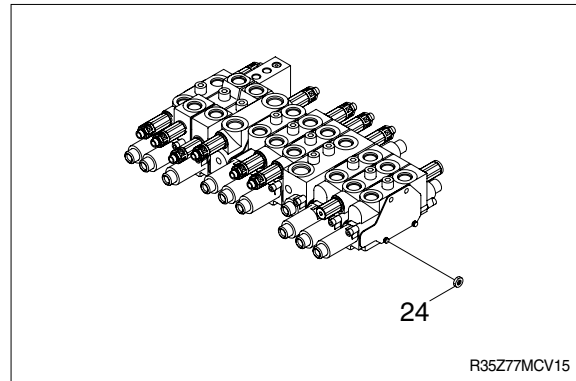

※ Do not removed the tie bolt(23).

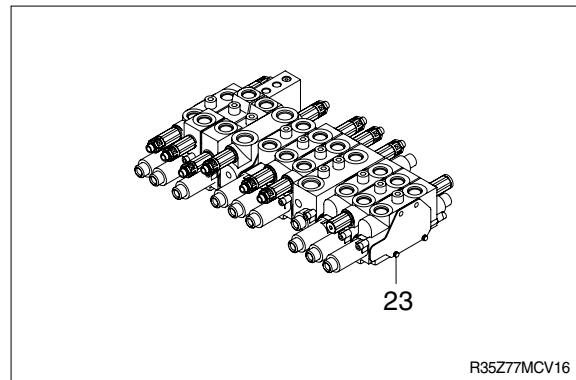

(6) Inspection after disassembly

Clean all disassembled parts with clean mineral oil fully, and dry them with compressed air. Then, place them on clean papers or cloths for inspection.

① Control valve

- a. Check whole surfaces of all parts for burrs, scratches, notches and other defects.
- b. Confirm that seal groove faces of body and block are smooth and free of dust, dent, rust etc.
- c. Correct dents and damages and check seat faces within the body, if any, by lapping.
※ Pay careful attention not to leave any lapping agent within the body.
- d. Confirm that all sliding and fitting parts can be moved manually and that all grooves and path's are free foreign matter.
- e. If any spring is broken or deformed, replace it with new one.
- f. When a relief valve does not function properly, repair it, following it's the prescribed disassembly and assembly procedures.
- g. Replace all seals and O-rings with new ones.

② Relief valve

- a. Confirm that all seat faces at ends of all poppets and seats are free of defects and show uniform and consistent contact faces.
- b. Confirm manually that main poppet and seat can slide lightly and smoothly.
- c. Confirm that outside face of main poppet and inside face of seat are free from scratches and so on.
- d. Confirm that springs are free from breakage, deformation, and wear.
- e. Confirm that orifices of main poppet and seat section are not clogged with foreign matter.
- f. Replace all O-rings with new ones.
- g. When any light damage is found in above inspections, correct it by lapping.
- h. When any abnormal part is found, replace it with a completely new relief valve assembly.

4) ASSEMBLY

(1) General precaution

- ① In this assembly section, explanation only is shown.
For further understanding, please refer to the figures shown in the previous structure & disassembly section.
- ② Pay close attention to keeping all seals free from handling damage and inspect carefully for damage before using them.
- ③ Apply clean grease or hydraulic oil to the seal so as to ensure it is fully lubricated before assembly.
- ④ Do not stretch seals so much as to deform them permanently.
- ⑤ In fitting O-rings, pay close attention not to roll them into their final position in addition, a twisted O-ring cannot easily untwist itself naturally and could thereby cause inadequate sealing and thereby both internal and external oil leakage.
- ⑥ Tighten fitting bolts for all sections with a torque wrench adjusted to the respective tightening torque.
- ⑦ Do not reuse removed O-rings and seals.

(2) Load check valve

- ① Assemble the load check valve(3) and O-ring(5), spring(4).
- ② Put O-rings on to plug(6).
- ③ Tighten plug to the specified torque.
 - Hexagon wrench : 8mm
 - Tightening torque : 3.7kgf · m
(26.7lbf · ft)

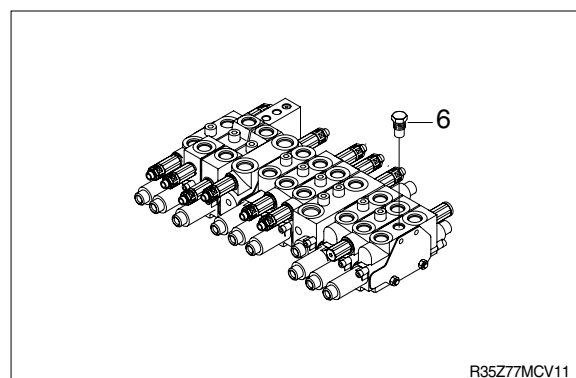
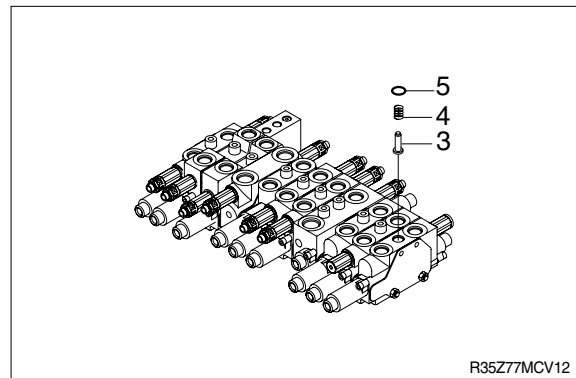

(3) Main relief, port relief valves

- ① Install the main relief valve(14).
 - Spanner : 30mm
 - Tightening torque : 6kgf · m(43.4lbf · ft)
- ② Install the over load relief valve(15).
 - Spanner : 22mm
 - Tightening torque : 4kgf · m(28.9lbf · ft)

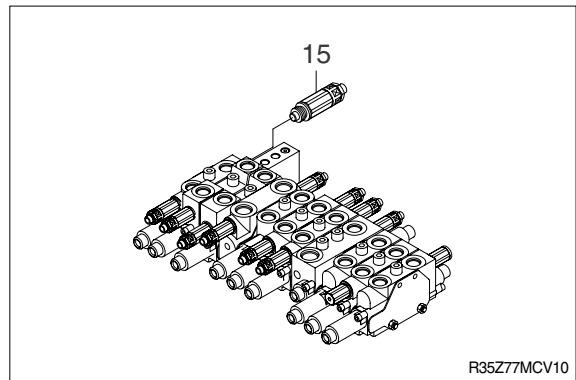
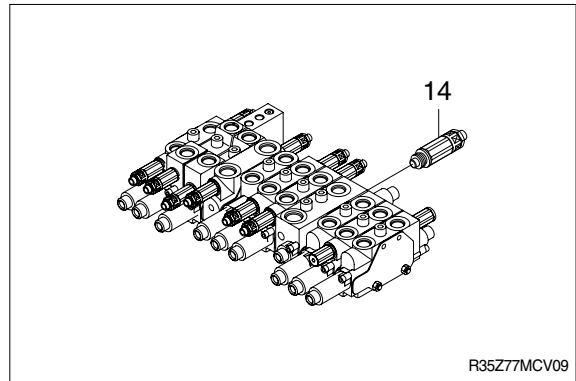

(4) Main spools

- ① Carefully insert the previously assembled spool assemblies into their respective bores within of body.
- ※ **Fit spool assemblies into body carefully and slowly. Do not under any circumstances push them forcibly in.**

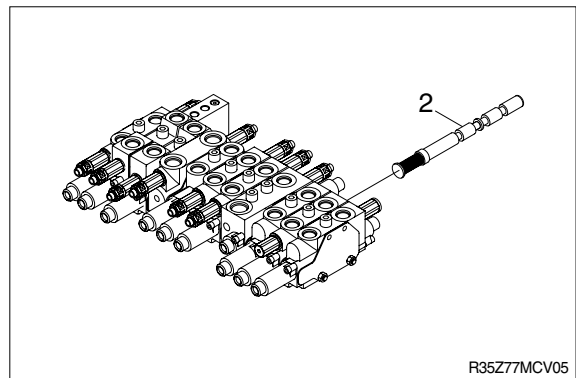

(5) Covers of pilot type

- ① Fit spool covers(8) tighten the hexagonal socket head bolts(10) with washer to the specified torque.
 - Hexagon wrench : 5mm
 - Tightening torque : 1~1.1kgf · m
(7.2~7.9lbf · ft)
- ※ Confirm that O-rings(7) have been fitted.

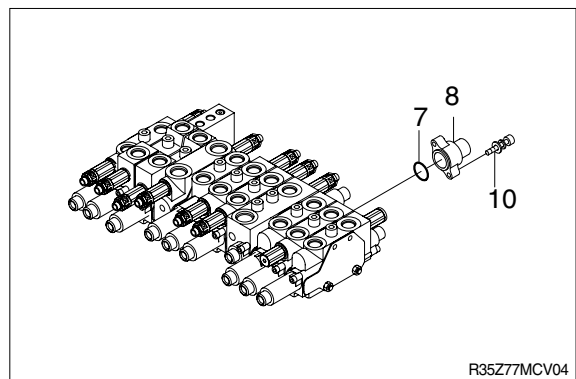

(6) Holding valve

① Fit the holding valve to the body and tighten hexagon socket head bolt(120) to specified torque.

- Hexagon wrench : 5mm
- Tightening torque : 1.1kgf · m (7.9lbf · ft)

