

GROUP 9 BOOM, ARM AND BUCKET CYLINDERS

1. REMOVAL AND INSTALL

1) BUCKET CYLINDER

(1) Removal

- ※ Expand the arm and bucket fully, lower the work equipment to the ground and stop the engine.
- ※ Operate the control levers and pedals several times to release the remaining pressure in the hydraulic piping.

▲ Loosen the breather slowly to release the pressure inside the hydraulic tank. Escaping fluid under pressure can penetrate the skin causing serious injury.

- ※ Fit blind plugs in the hoses after disconnecting them, to prevent dirt or dust from entering.

① Set block between bucket cylinder and arm.

② Remove bolt(2), nut(3) and pull out pin (1).

- ※ Tie the rod with wire to prevent it from coming out.

③ Disconnect bucket cylinder hoses(4) and put plugs(5) on cylinder pipe.



13031GE18

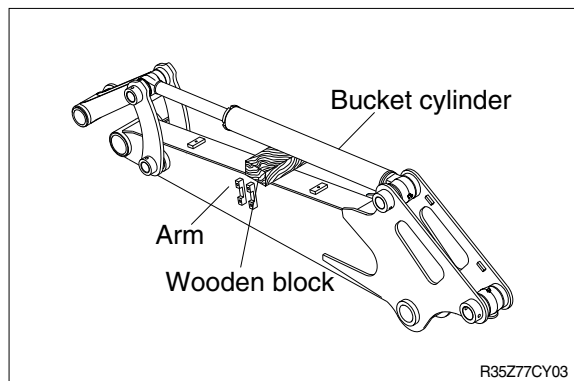

R35Z77CY03

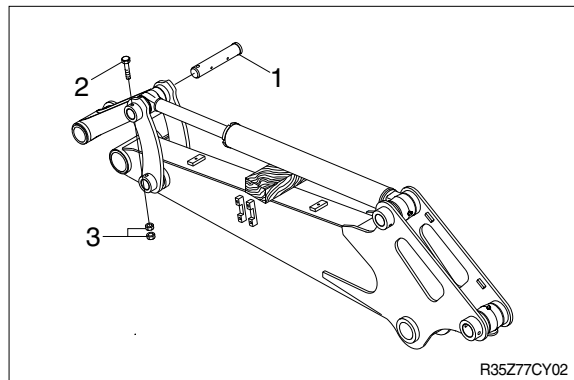

R35Z77CY02

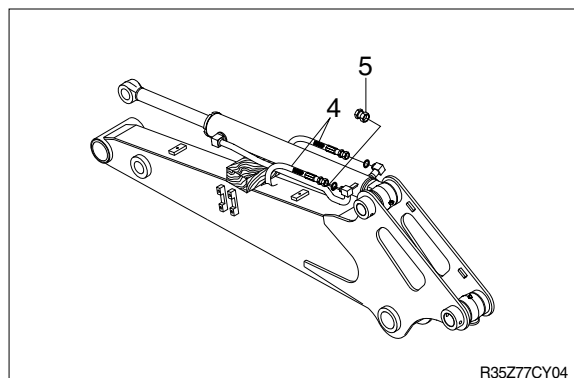

R35Z77CY04

- ④ Sling bucket cylinder assembly(9) and remove bolt(6) and nut(7) then pull out pin (8).
- ⑤ Remove bucket cylinder assembly(9).
 - Weight : 30kg(70lb)

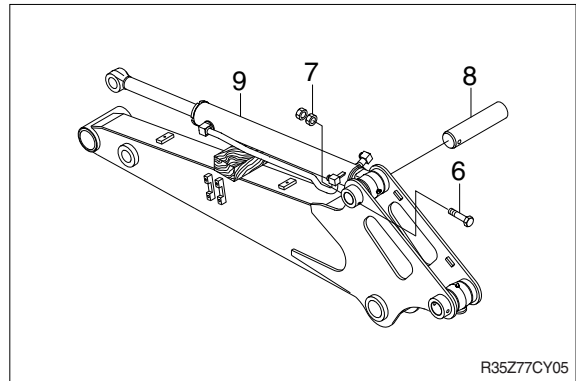

(2) Install

- ① Carry out installation in the reverse order to removal.
- ▲ When aligning the mounting position of the pin, do not insert your fingers in the pin hole.**
- ※ Bleed the air from the bucket cylinder.
 - ※ Confirm the hydraulic oil level and check the hydraulic oil leak or not.

2) ARM CYLINDER

(1) Removal

- ※ Expand the arm and bucket fully, lower the work equipment to the ground and stop the engine.
- ※ Operate the control levers and pedals several times to release the remaining pressure in the hydraulic piping.

▲ Loosen the breather slowly to release the pressure inside the hydraulic tank.

▲ Escaping fluid under pressure can penetrate the skin causing serious injury.

- ※ Fit blind plugs in the hoses after disconnecting them, to prevent dirt or dust from entering.

① Set block between arm cylinder and boom.

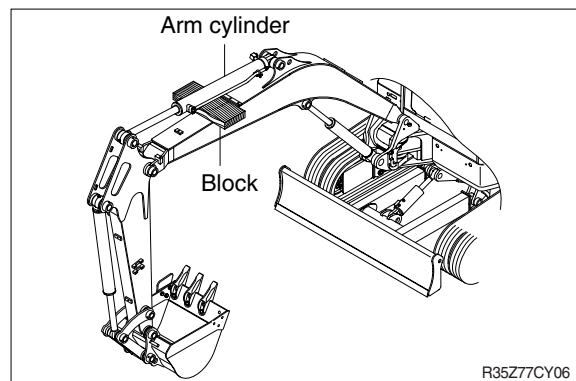

② Remove bolt and nut(2) and pull out pin(1).

- ※ Tie the rod with wire to prevent it from coming out.

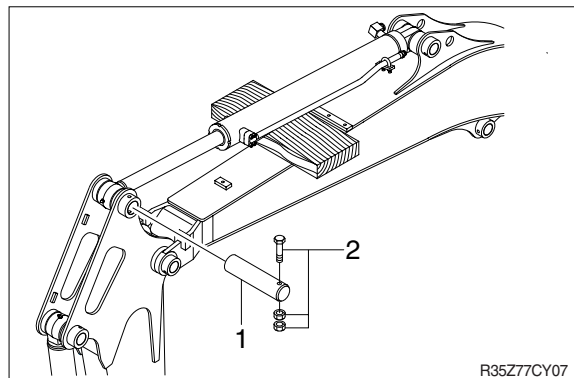

③ Disconnect arm cylinder hoses(4) and put plugs on cylinder pipe.

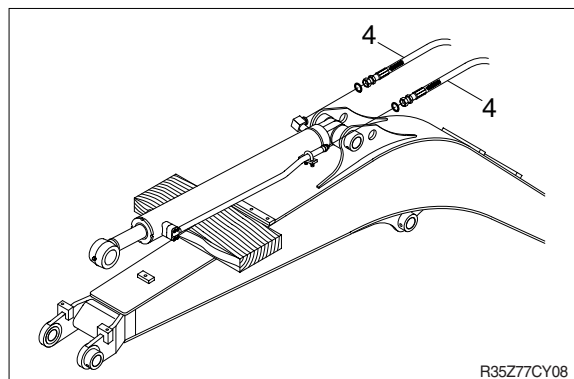

- ⑤ Sling arm assembly(8) and remove bolt and nut(7) then pull out pin(6).
- ⑥ Remove arm cylinder assembly(8).
 - Weight : 40kg(90lb)

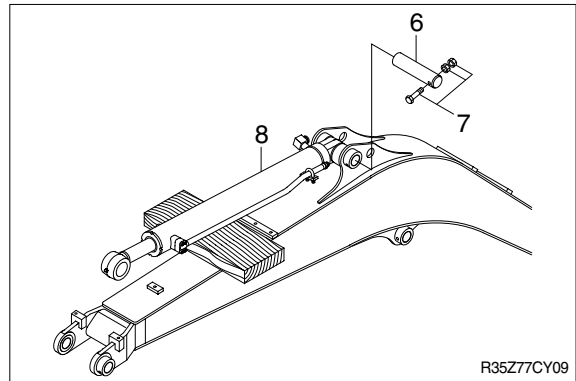

(2) Install

- ① Carry out installation in the reverse order to removal.
- ▲ When aligning the mounting position of the pin, do not insert your fingers in the pin hole.**
- ※ Bleed the air from the arm cylinder.
 - ※ Confirm the hydraulic oil level and check the hydraulic oil leak or not.

3) BOOM CYLINDER

(1) Removal

- ※ Expand the arm and bucket fully, lower the work equipment to the ground and stop the engine.
- ※ Operate the control levers and pedals several times to release the remaining pressure in the hydraulic piping.

▲ Loosen the breather slowly to release the pressure inside the hydraulic tank.

▲ Escaping fluid under pressure can penetrate the skin causing serious injury.

- ※ Fit blind plugs in the hoses after disconnecting them, to prevent dirt or dust from entering.

① Sling boom cylinder assembly.

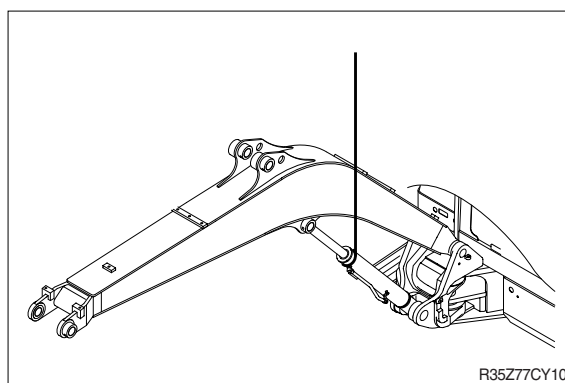

③ Remove bolt and nut(2) and pull out pin(1).

- ※ Tie the rod with wire to prevent it from coming out.

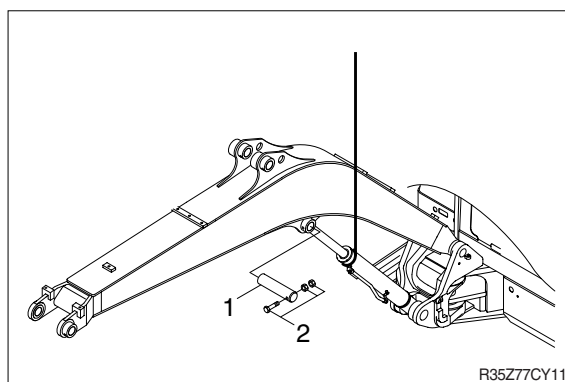

④ Lower the boom cylinder assembly(3) on a stand.

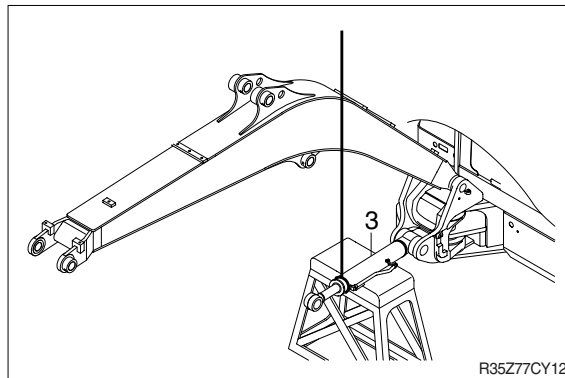

- ⑤ Disconnect boom cylinder hoses(4) and put plugs on cylinder pipe.

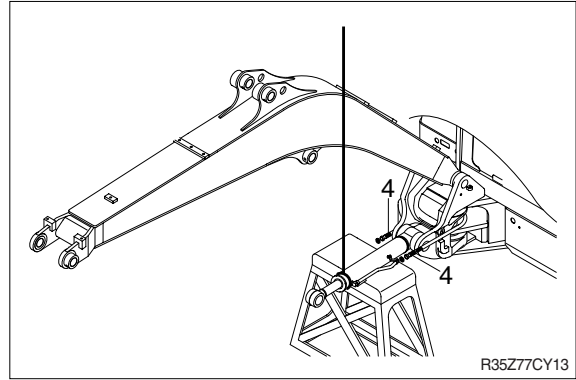

- ⑥ Remove bolt(6) and pull out pin(5).
⑦ Remove boom cylinder assembly(3).
· Weight : 60kg(130lb)

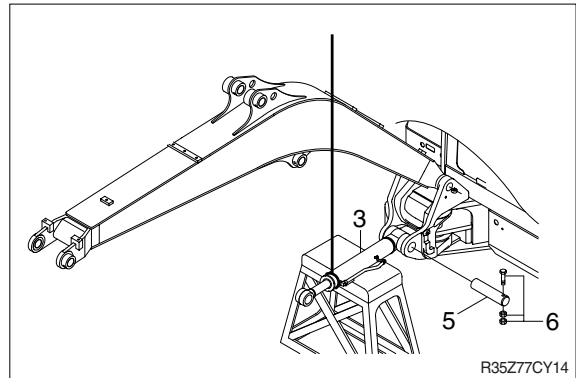

(2) Install

- ① Carry out installation in the reverse order to removal.

▲ When aligning the mounting position of the pin, do not insert your fingers in the pin hole.

- ※ Bleed the air from the boom cylinder.
- ※ Confirmed the hydraulic oil level and check the hydraulic oil leak or not.

2. DISASSEMBLY AND ASSEMBLY

1) STRUCTURE

(1) Bucket cylinder

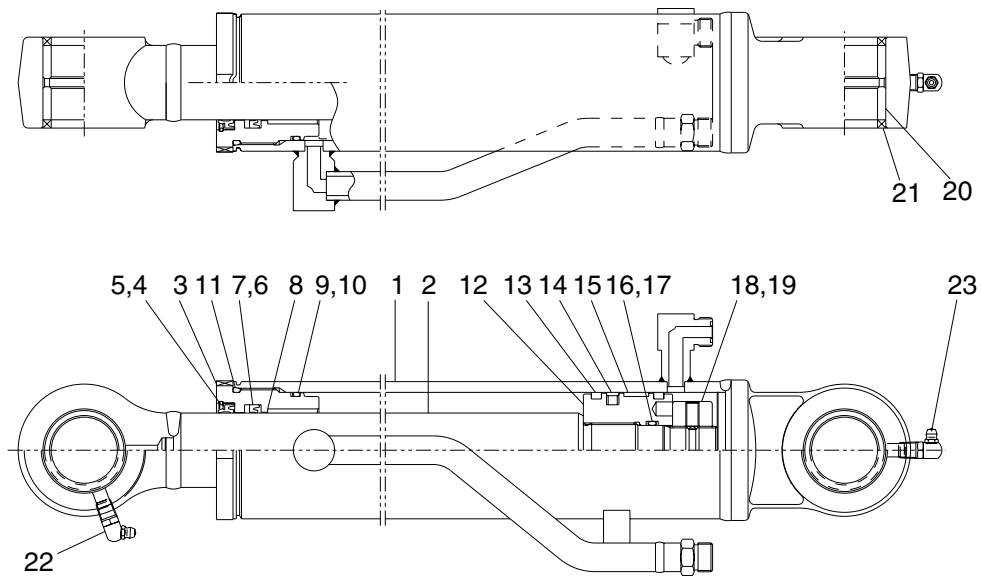

1	Tube assembly	9	O-ring	17	Back-up ring
2	Rod assembly	10	Back-up ring	18	Piston nut
3	Gland	11	O-ring	19	Set screw
4	Dust wiper	12	Piston	20	Pin bush
5	Retaining ring	13	Dust ring	21	Dust seal
6	Rod seal	14	Piston seal	22	Grease nipple
7	Back-up ring	15	Wear ring	23	Grease nipple
8	DU bush	16	O-ring		

R35Z77CY15

(2) Arm cylinder

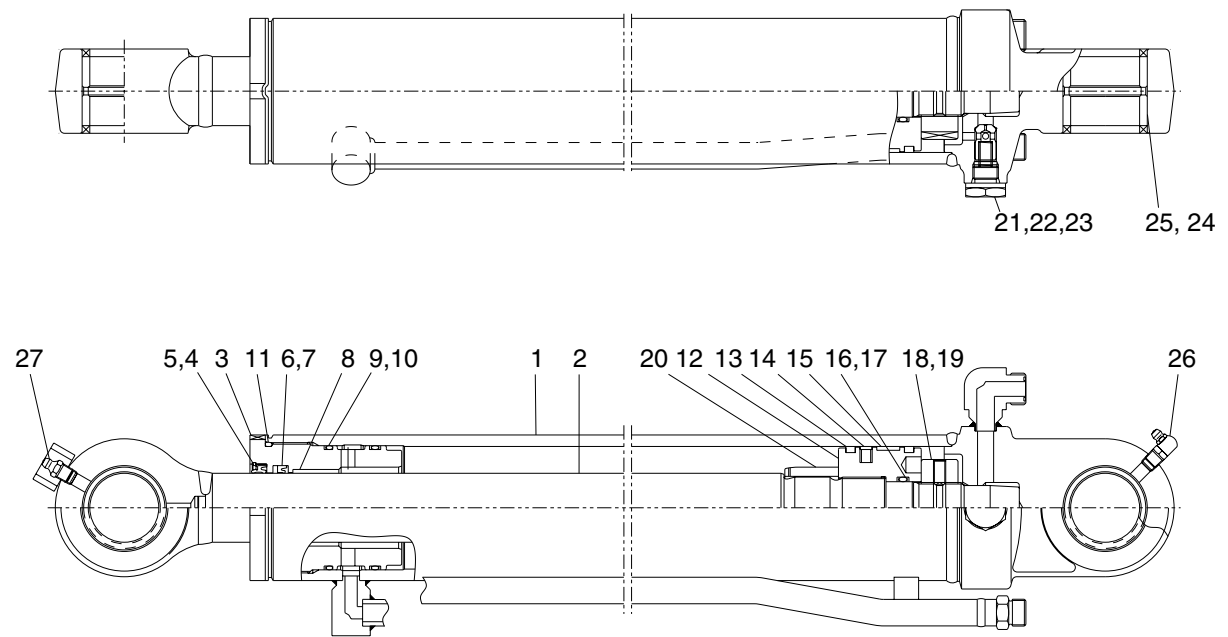

R35Z77CY16

1	Tube assembly	10	Back-up ring	19	Set screw
2	Rod assembly	11	O-ring	20	Cushion ring
3	Gland	12	Piston	21	Check valve
4	Dust wiper	13	Dust ring	22	Spring
5	Retaining ring	14	Piston seal	23	Plug
6	Rod seal	15	Wearing	24	Pin bush
7	Back-up ring	16	O-ring	25	Dust seal
8	DU bush	17	Back-up ring	26	Grease nipple
9	O-ring	18	Piston nut	27	Grease nipple

(3) Boom cylinder

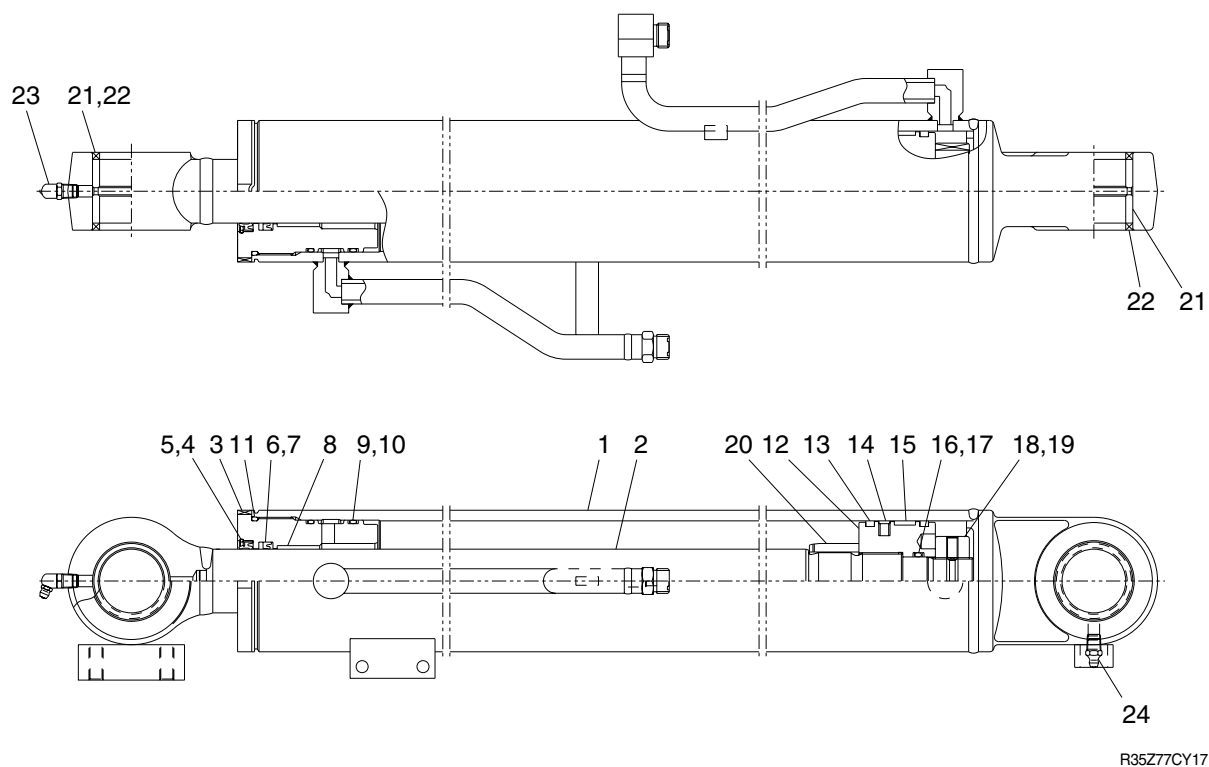

R35Z77CY17

- | | | | | | |
|---|----------------|----|--------------|----|---------------|
| 1 | Tube assembly | 9 | O-ring | 17 | Back-up ring |
| 2 | Rod assembly | 10 | Back-up ring | 18 | Piston nut |
| 3 | Gland | 11 | O-ring | 19 | Set screw |
| 4 | Dust wiper | 12 | Piston | 20 | Cushion ring |
| 5 | Retaining ring | 13 | Dust ring | 21 | Pin bush |
| 6 | Rod seal | 14 | Piston seal | 22 | Dust seal |
| 7 | Back-up ring | 15 | Wearing | 23 | Grease nipple |
| 8 | DU bush | 16 | O-ring | 24 | Grease nipple |

(4) Dozer cylinder

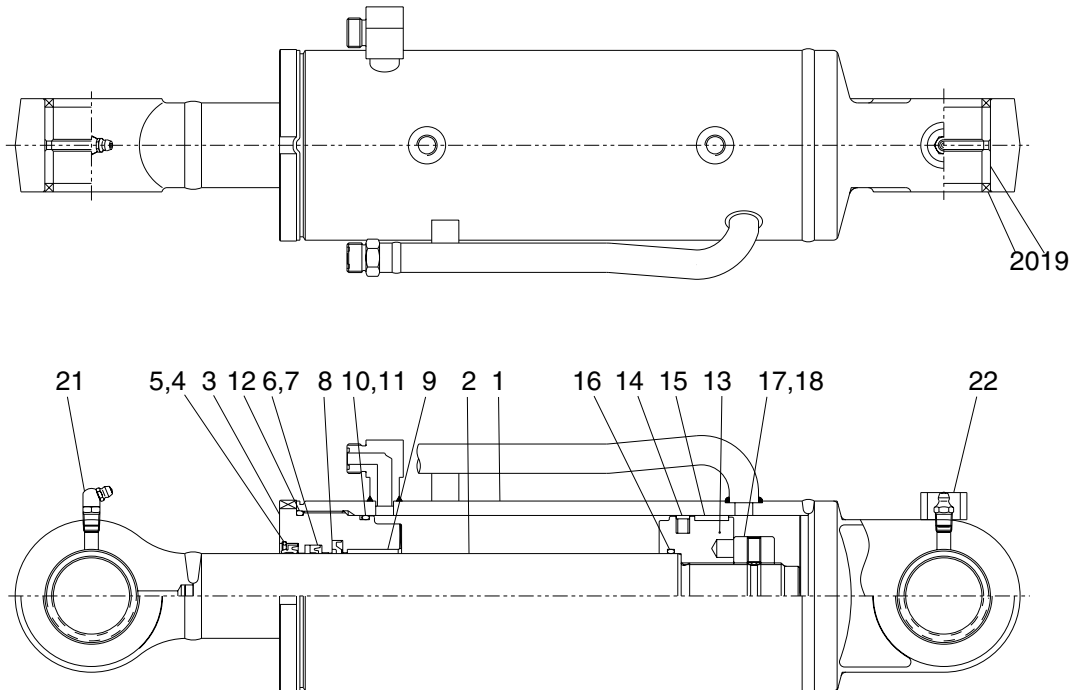

R35Z77CY18

- | | | | | | |
|---|----------------|----|--------------|----|---------------|
| 1 | Tube assembly | 8 | Buffer ring | 15 | Wear ring |
| 2 | Rod assembly | 9 | DU bush | 17 | Piston nut |
| 3 | Gland | 10 | O-ring | 18 | Set screw |
| 4 | Dust wiper | 11 | Back-up ring | 19 | Pin bush |
| 5 | Retaining ring | 12 | O-ring | 20 | Dust seal |
| 6 | Rod seal | 13 | Piston | 21 | Grease nipple |
| 7 | Back-up ring | 14 | Piston seal | 22 | Grease nipple |

(5) Boom swing cylinder

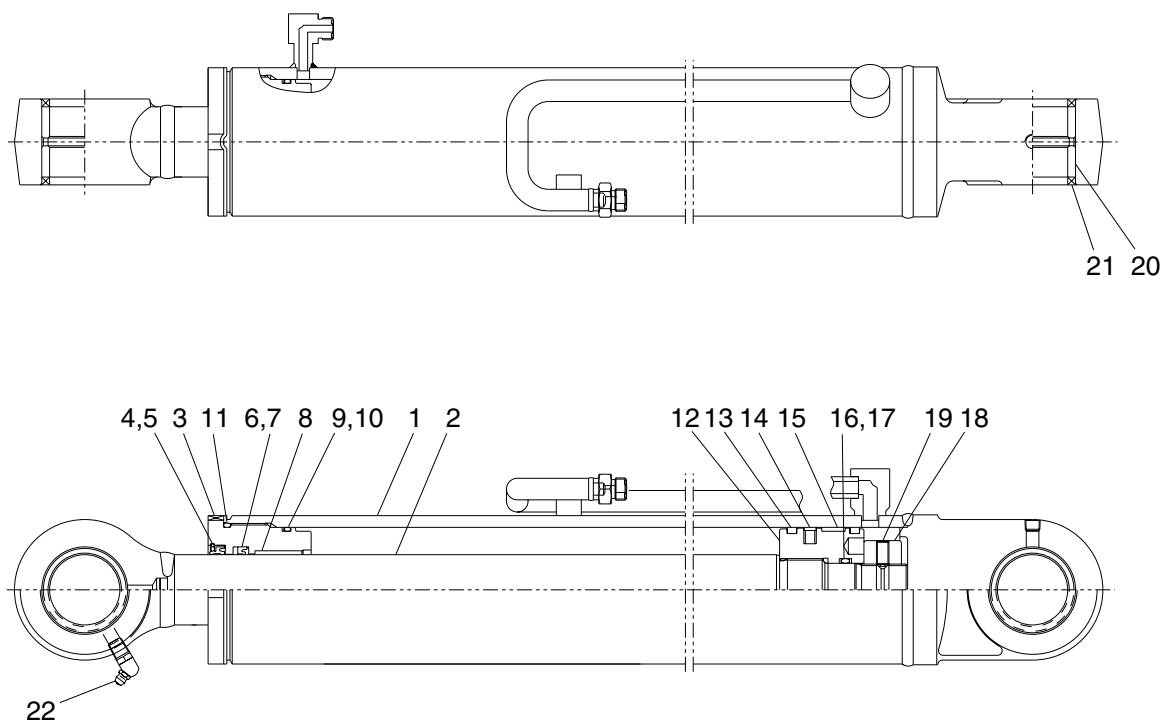

- | | | | | | |
|---|----------------|----|--------------|----|---------------|
| 1 | Tube assembly | 8 | O-ring | 16 | O-ring |
| 2 | Rod assembly | 9 | Back-up ring | 17 | Back-up ring |
| 3 | Gland | 10 | O-ring | 18 | Piston nut |
| 4 | Dust wiper | 11 | O-ring | 19 | Set screw |
| 5 | Retaining ring | 12 | Piston | 20 | Pin bush |
| 6 | Rod seal | 13 | Dust ring | 21 | Dust seal |
| 7 | Back-up ring | 14 | Piston seal | 22 | Grease nipple |
| 8 | DU bush | 15 | Wear ring | | |

R35Z77CY19

2) TOOLS AND TIGHTENING TORQUE

(1) Tools

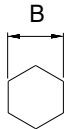
Name	Specification	
Allen wrench	8	
	3	
Spanner	M22	
Hook spanner	Suitable size(80~120 mm)	
(-) Driver	Small and large sizes	
Torque wrench	Capable of tightening with the specified torques	

(2) Tightening torque

Part name		Item	Size	Torque	
				kgf · m	lbf · ft
Gland	Boom cylinder	3	M90	68±6.8	492±49
	Arm cylinder	3	M85	64±6.4	463±46
	Bucket cylinder	3	M75	56±5.6	405±41
	Dozer cylinder	3	M100	75±7.5	542±54
	Boom swing cylinder	3	M85	64±6.4	463±46
Piston nut	Boom cylinder	18	M33	82±8	593±59
	Arm cylinder	18	M33	82±8	593±59
	Bucket cylinder	18	M29	73±7	528±53
	Dozer cylinder	17	M39	150±15	1085±109
	Boom swing cylinder	18	M33	93±9	673±67

3) DISASSEMBLY

※ Procedures are based on the boom cylinder.

(1) Remove cylinder head and piston rod

① Hold the clevis section of the tube in a vise.

※ Use mouth pieces so as not to damage the machined surface of the cylinder tube. Do not make use of the outside piping as a locking means.

② Pull out rod assembly(2) about 200mm (7.1in). Because the rod assembly is rather heavy, finish extending it with air pressure after the oil draining operation.

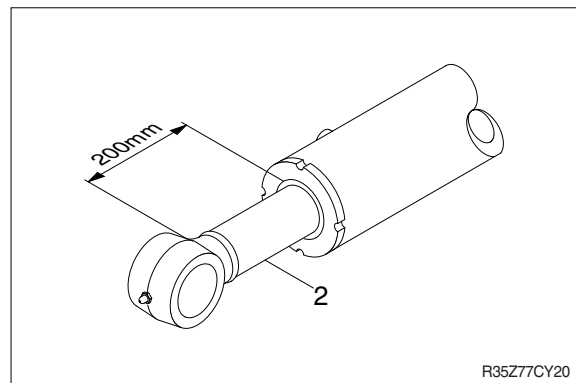

③ Loosen and remove the gland(3) by hook spanner.

※ Cover the extracted rod assembly(2) with rag to prevent it from being accidentally damaged during operation.

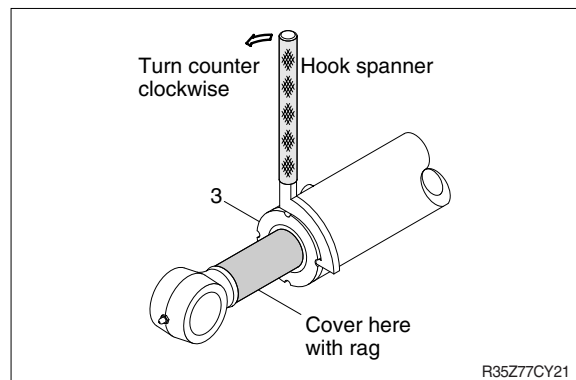

④ Draw out cylinder head and rod assembly together from tube assembly(1).

※ Since the rod assembly is heavy in this case, lift the tip of the rod assembly(2) with a crane or some means and draw it out. However, when rod assembly(2) has been drawn out to approximately two thirds of its length, lift it in its center to draw it completely.

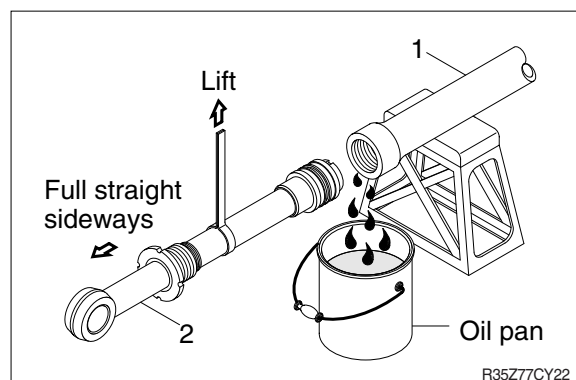

Note that the plated surface of rod assembly(2) is to be lifted. For this reason, do not use a wire sling and others that may damage it, but use a strong cloth belt or a rope.

- ⑤ Place the removed rod assembly on a wooden V-block that is set level.
- ※ Cover a V-block with soft rag.

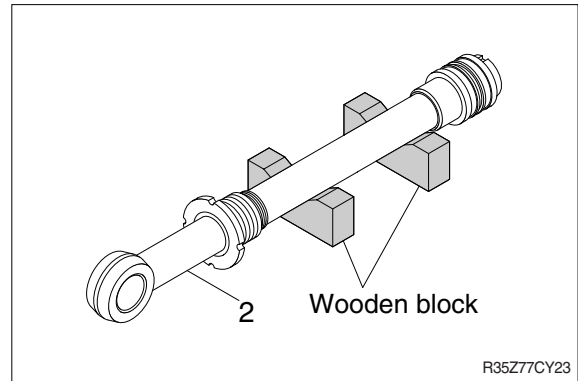

(2) Remove piston and gland

- ① Remove set screw(19)
- ② Remove piston nut(18).
- ※ Since piston nut(18) is tightened to a high torque, use a hydraulic and power wrench that utilizes a hydraulic cylinder, to remove the piston nut(18).
- ③ Remove piston assembly(12), back up ring(17), O-ring(10) and cushion ring (20).

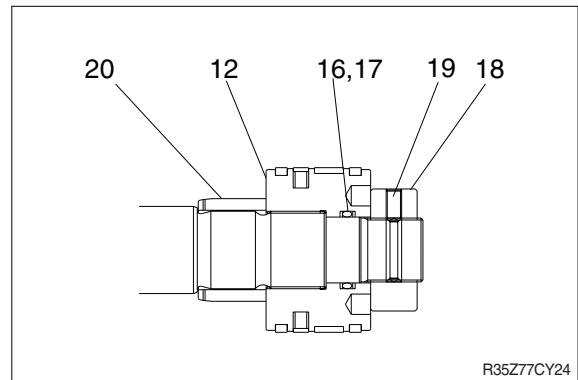

- ④ Remove the gland assembly from rod assembly(2).
 - ※ If it is too heavy to move, move it by striking the flanged part of gland with a plastic hammer.
 - ※ Pull it straight with gland assembly lifted with a crane.
- Exercise care so as not to damage the lip of DU bushing(8) and packing (4,5,6,7, 9,10) by the threads of rod assembly(2).

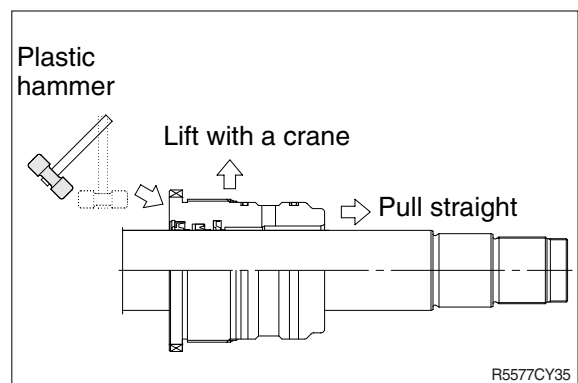

(3) Disassemble the piston assembly

- ① Remove wear ring(15).
 - ② Remove dust ring(13) and piston seal (14).
- ※ Exercise care in this operation not to damage the grooves.

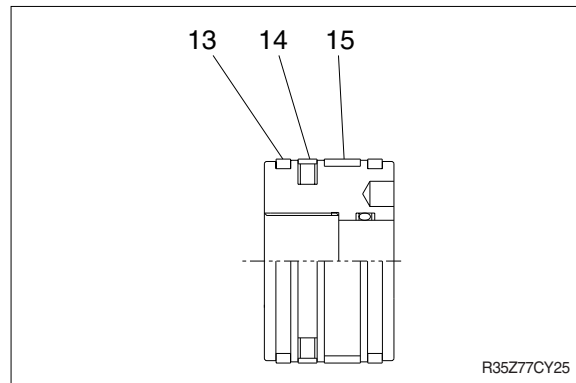

(4) Disassemble gland assembly

- ① Remove back up ring(10) and O-ring (9).
 - ② Remove snap ring(5), dust wiper(4).
 - ③ Remove back up ring(7), rod seal(6).
 - ④ Remove the cushion ring (8).
- ※ Exercise care in this operation not to damage the grooves.
- ※ Do not remove seal and ring, if does not damaged.

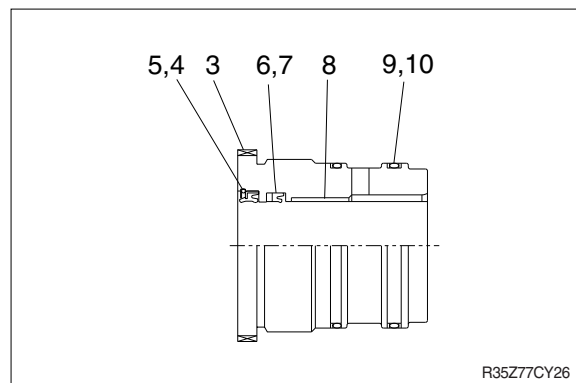

4) ASSEMBLY

(1) Assemble cylinder head assembly

※ Check for scratches or rough surfaces if found smooth with an oil stone.

① Coat the inner face of gland(3) with hydraulic oil.

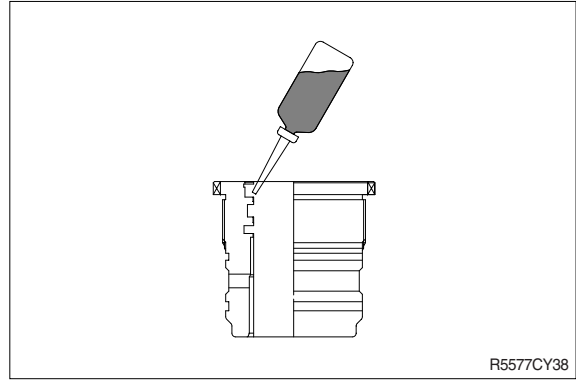

② Coat dust wiper(4) with grease and fit dust wiper(4) to the bottom of the hole of dust seal.

At this time, press a pad metal to the metal ring of dust seal.

③ Fit retain ring(5) to the stop face.

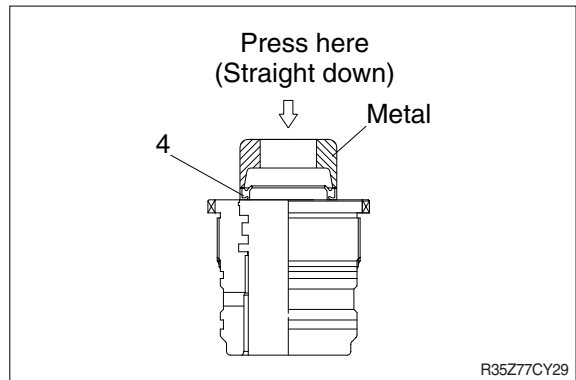

④ Fit back up ring(7), rod seal(6) to corresponding grooves, in that order.

Coat each packing with hydraulic oil

※ before fitting it.

Insert the backup ring until one side of it

※ is inserted into groove.

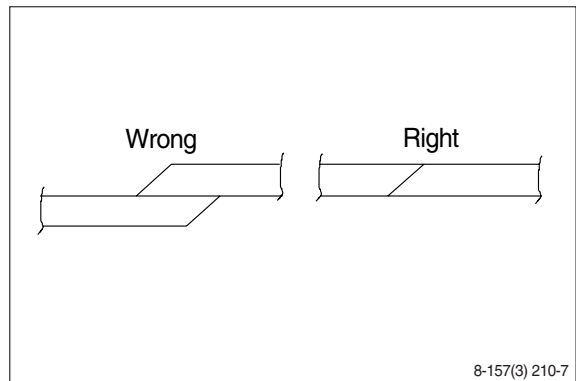

※ Rod seal(6) has its own fitting direction. Therefore, confirm it before fitting them.

※ Fitting rod seal(6) upside down may damage its lip. Therefore check the correct direction that is shown in fig.

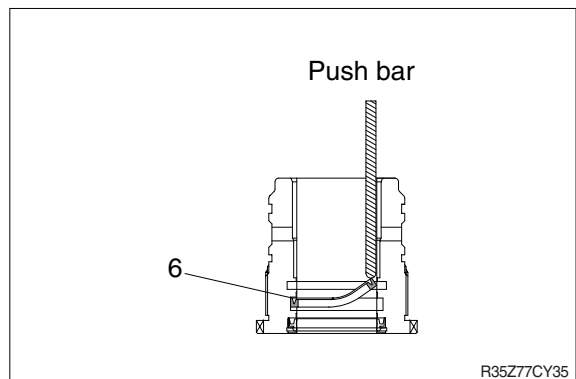

- ⑤ Fit back up ring(10) to gland(3).
- ※ Put the backup ring in the warm water of 30~50° C .
- ⑥ Fit O-ring(9) to gland(3).

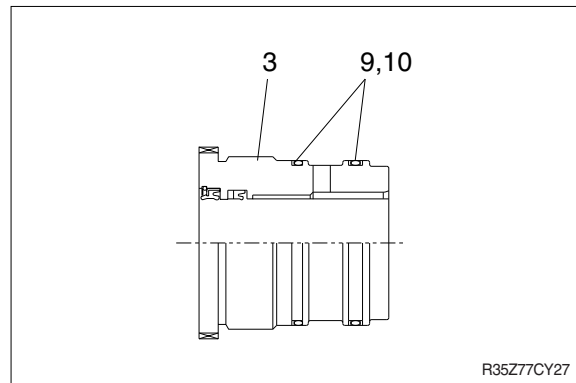

(2) Assemble piston assembly

- ※ Check for scratches or rough surfaces. If found smooth with an oil stone.
- ① Coat the outer face of piston(16) with hydraulic oil.

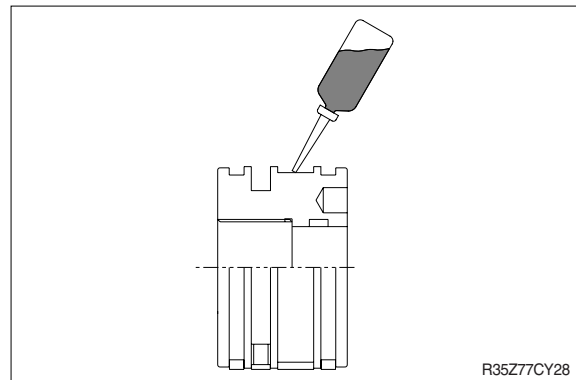

- ② Fit piston seal(14) to piston.
- ※ Put the piston seal in the warm water of 60~100° C for more than 5 minutes.
- ※ After assembling the piston seal, press its outer diameter to fit in.

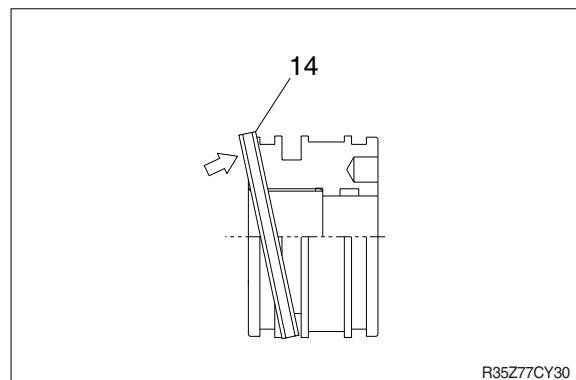

- ③ Fit wear ring(15) and dust ring(13) to piston(12).

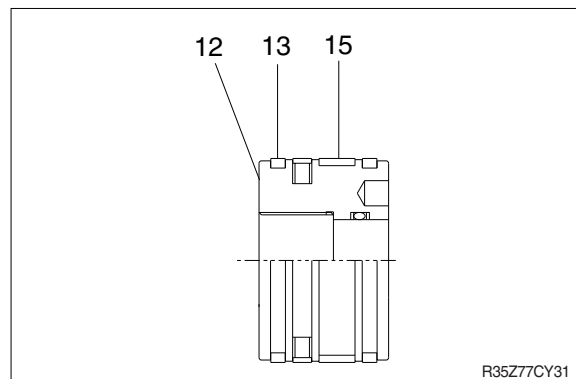

(3) Install piston and cylinder head

- ① Fix the rod assembly to the work bench.
- ② Apply hydraulic oil to the outer surface of rod assembly(2), the inner surface of piston and gland.
- ③ Insert gland assembly to rod assembly.

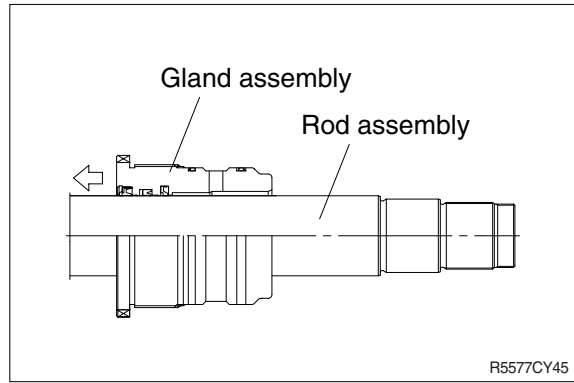

- ④ Insert cushion ring(20) to rod assembly.
- ※ Note that cushion ring(20) has a direction in which it should be fitted.

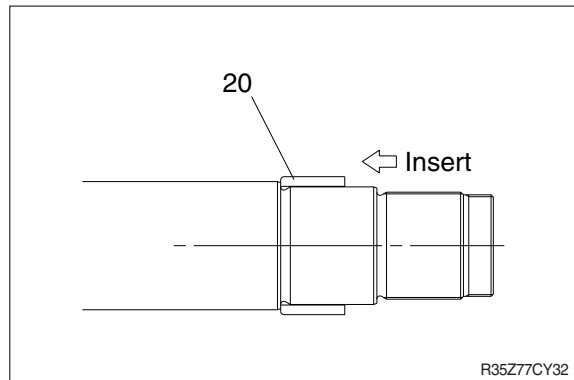

- ⑤ Fit piston assembly to rod assembly.

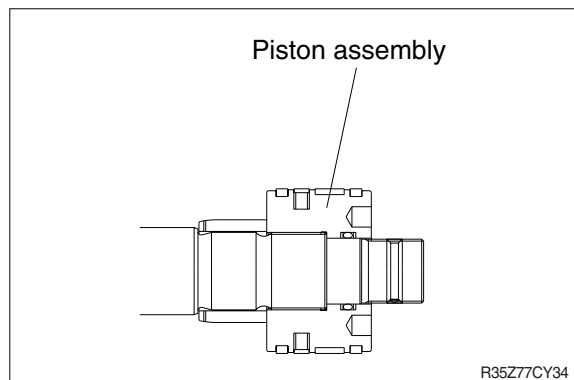

- ⑥ Fit piston nut(18) and set screw(19).
- Tightening torque :

Item		kgf · m	lbf · ft
Boom	18	82 ± 8	593 ± 59
Arm	18	82 ± 8	593 ± 59
Bucket	18	73 ± 7	528 ± 53
Dozer	17	150 ± 15	1085 ± 109
Boom swing	18	93 ± 9	673 ± 67

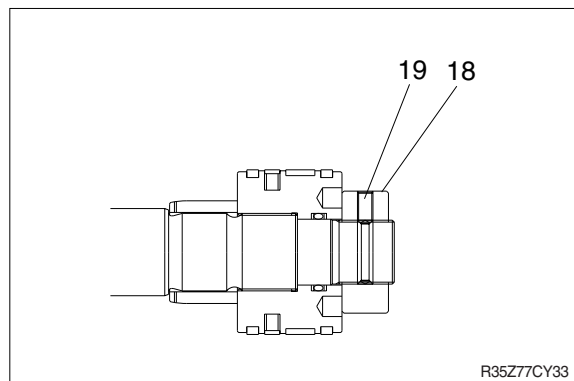

(3) Overall assemble

- ① Place a V-block on a rigid work bench.
Mount the tube assembly(1) on it and fix the assembly by passing a bar through the clevis pin hole to lock the assembly.
- ② Insert the rod assembly in to the tube assembly, while lifting and moving the rod assembly with a crane.
 - ※ Be careful not to damage piston seal by thread of tube assembly.
- ③ Match the bolt holes in the cylinder head flange to the tapped holes in the tube assembly and tighten socket bolts to a specified torque.
 - ※ Refer to the table of tightening torque.

