

GROUP 8 TURNING JOINT

1. REMOVAL AND INSTALL

1) REMOVAL

- (1) Lower the work equipment to the ground and stop the engine.
- (2) Operate the control levers and pedals several times to release the remaining pressure in the hydraulic piping.
- (3) Loosen the breather slowly to release the pressure inside the hydraulic tank.
 - ▲ Escaping fluid under pressure can penetrate the skin causing serious injury.
 - ※ When pipes and hoses are disconnected, the oil inside the piping will flow out, so catch it in oil pan.
- (4) Disconnect all hoses.
- (5) Sling the turning joint assembly (1) and remove the mounting bolt(2).
 - Weight : 15kg(35lb)
 - Tightening torque : $6.9 \pm 1.4\text{kgf} \cdot \text{m}$
($49.9 \pm 10.1\text{lbf} \cdot \text{ft}$)
- (6) Remove the turning joint assembly.
 - ※ When removing the turning joint, check that all the hoses have been disconnected.

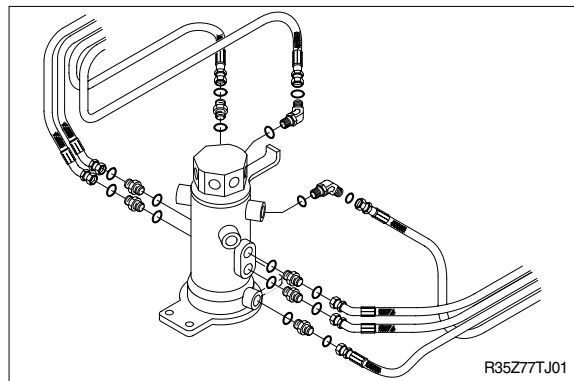

2) INSTALL

- (1) Carry out installation in the reverse order to removal.
 - ※ Take care of turning joint direction.
 - ※ Assemble hoses to their original positions.
 - ※ Confirm the hydraulic oil level and check the hydraulic oil leak or not.

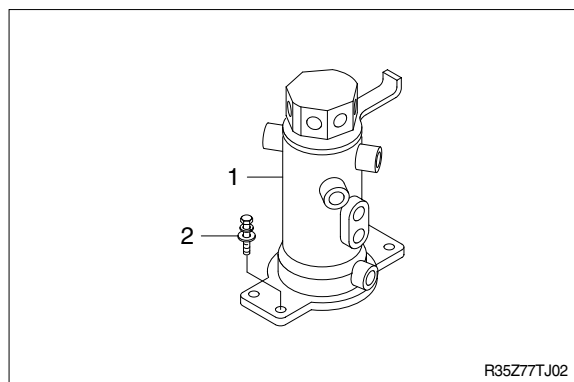

2. DISASSEMBLY AND ASSEMBLY

1) STRUCTURE

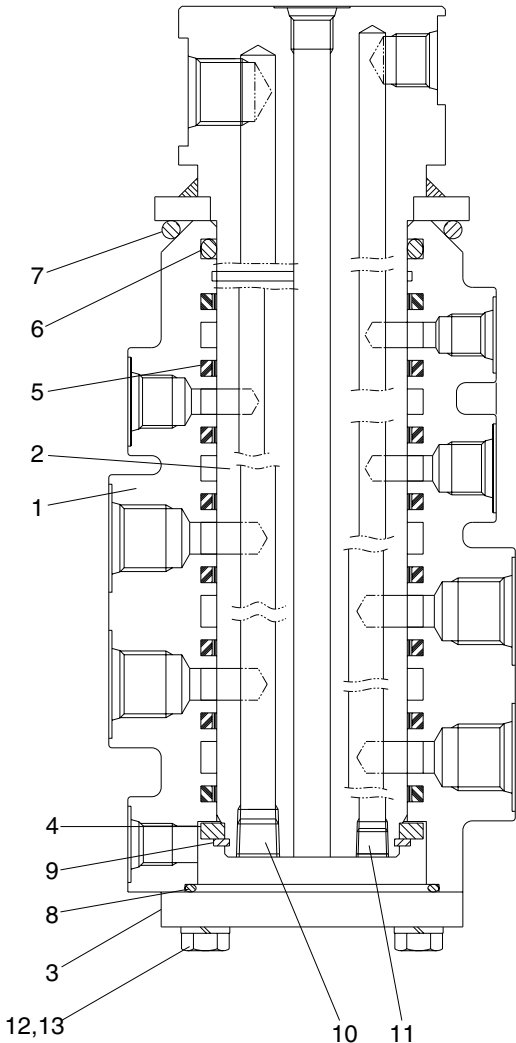

R35Z77J03

- | | | | | | |
|---|--------------|---|---------------|----|---------------|
| 1 | Hub | 6 | O-ring | 10 | Plug |
| 2 | Shaft | 7 | O-ring | 11 | Plug |
| 3 | Cover | 8 | O-ring | 12 | Hexagon bolt |
| 4 | Spacer | 9 | Retainer ring | 13 | Spring washer |
| 5 | Slipper seal | | | | |

2) DISASSEMBLY

※ Before the disassembly, clean the turning joint.

(1) Remove bolts(12), washer(13) and cover(3).

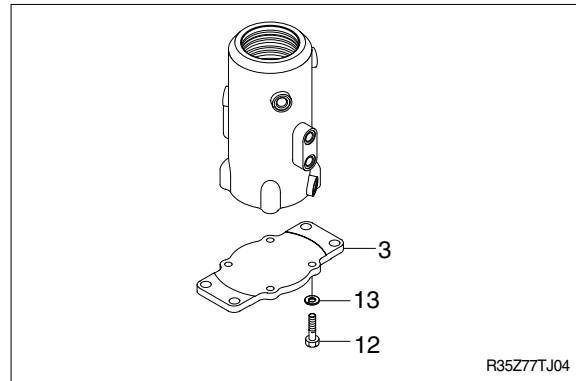

(2) Remove O-ring(8).

(3) Remove retainer ring(9) and spacer(4).

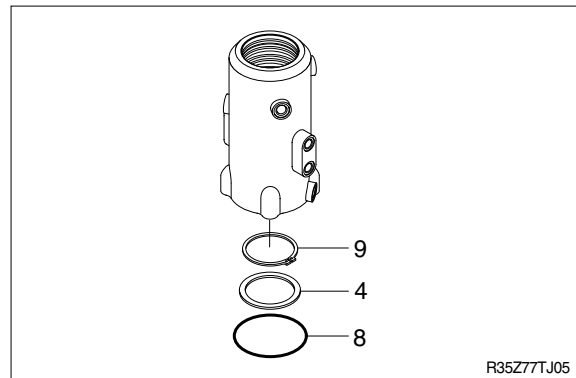

(4) Place hub(1) on a V-block and by using a wood buffer at the shaft end, hit out shaft(2) to about 1/2 from the body with a hammer.

※ Take care not to damage the shaft(2) when remove hub(1) or rest it sideways.

※ Put a fitting mark on hub(1) and shaft(2).

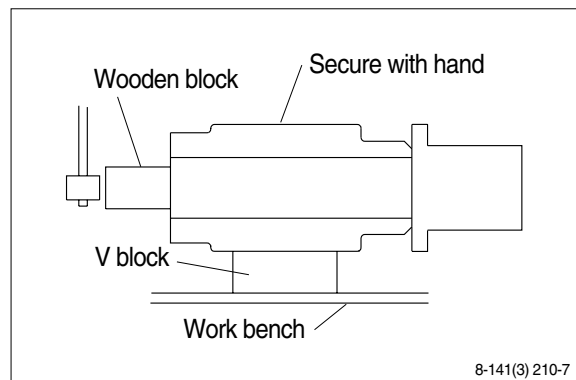

(5) Remove eight slipper seals(5) and O-ring(6, 7) from hub(1).

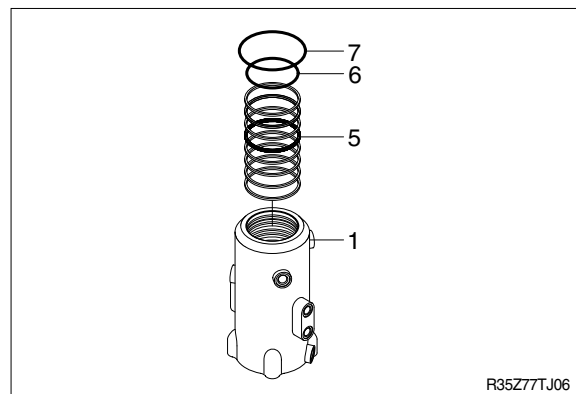

3) ASSEMBLY

- ※ Clean all parts.
- ※ As a general rule, replace oil seals and O-ring.
- ※ Coat the sliding surfaces of all parts with engine oil or grease before installing.

(1) Fix eight slipper seal(5) and O-ring(6, 7)to hub(1).

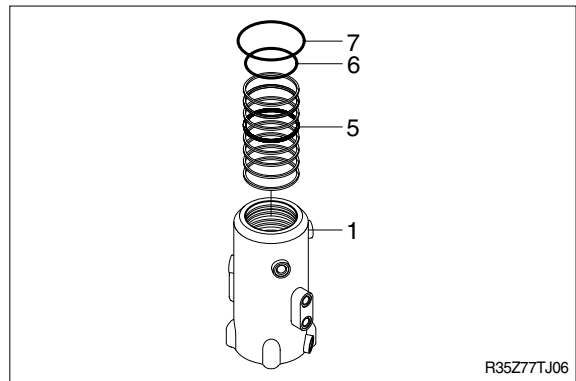

(2) Set hub(1) on block, install shaft(2) into hub(1) by hand.

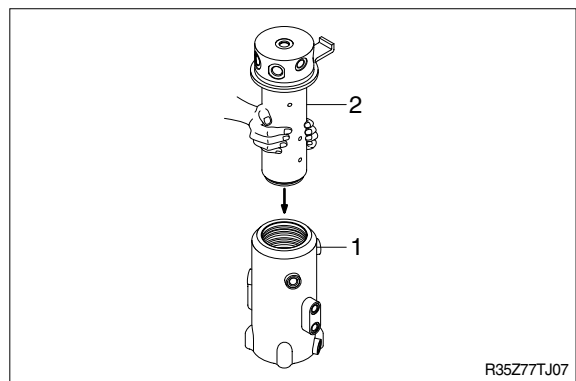

(3) Fit spacer(4) and retainer ring(9) to shaft(2).

(4) Fit O-ring(8) to hub(1).

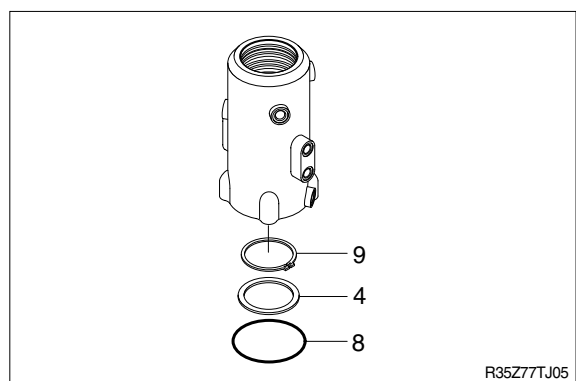

(5) Install cover(3) to hub and tighten bolts(12).

