

GROUP 5 SWING DEVICE

1. REMOVAL AND INSTALL OF MOTOR

1) REMOVAL

- (1) Lower the work equipment to the ground and stop the engine.
- (2) Operate the control levers and pedals several times to release the remaining pressure in the hydraulic piping.
- (3) Loosen the breather slowly to release the pressure inside the hydraulic tank.
- ▲ Escaping fluid under pressure can penetrate the skin causing serious injury.
- ※ When pipes and hoses are disconnected, the oil inside the piping will flow out, so catch it in oil pan.
- (4) Disconnect hose assembly(78, 102, 103).
- (5) Disconnect pilot line hoses(27, 29, 32).
- (6) Sling the swing motor assembly(1) and remove the swing motor mounting bolts (24).

- ※ Motor device weight : 39kg(86lb)
- (7) Remove the swing motor assembly.
 - ※ When removing the swing motor assembly, check that all the piping have been disconnected.

2) INSTALL

- (1) Carry out installation in the reverse order to removal.
- (2) Bleed the air from the swing motor.
 - ① Remove the air vent plug.
 - ② Pour in hydraulic oil until it overflows from the port.
 - ③ Tighten plug lightly.
 - ④ Start the engine, run at low idling and check oil come out from plug.
 - ⑤ Tighten plug fully.
- (3) Confirm the hydraulic oil level and check the hydraulic oil leak or not.

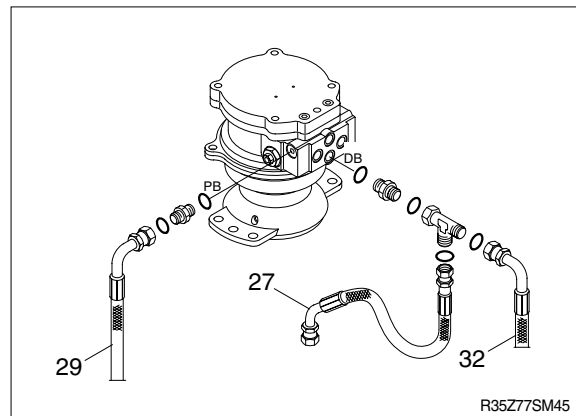
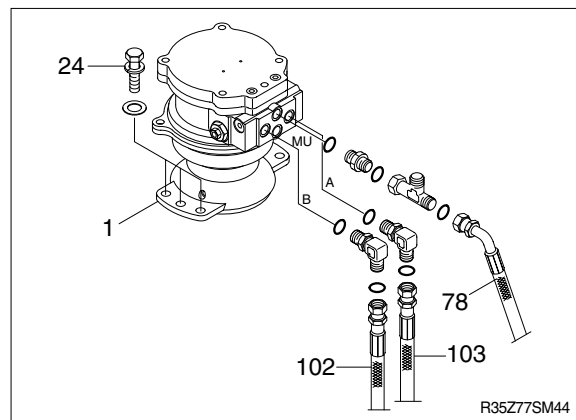

2. DISASSEMBLY AND ASSEMBLY OF SWING MOTOR

1) STRUCTURE

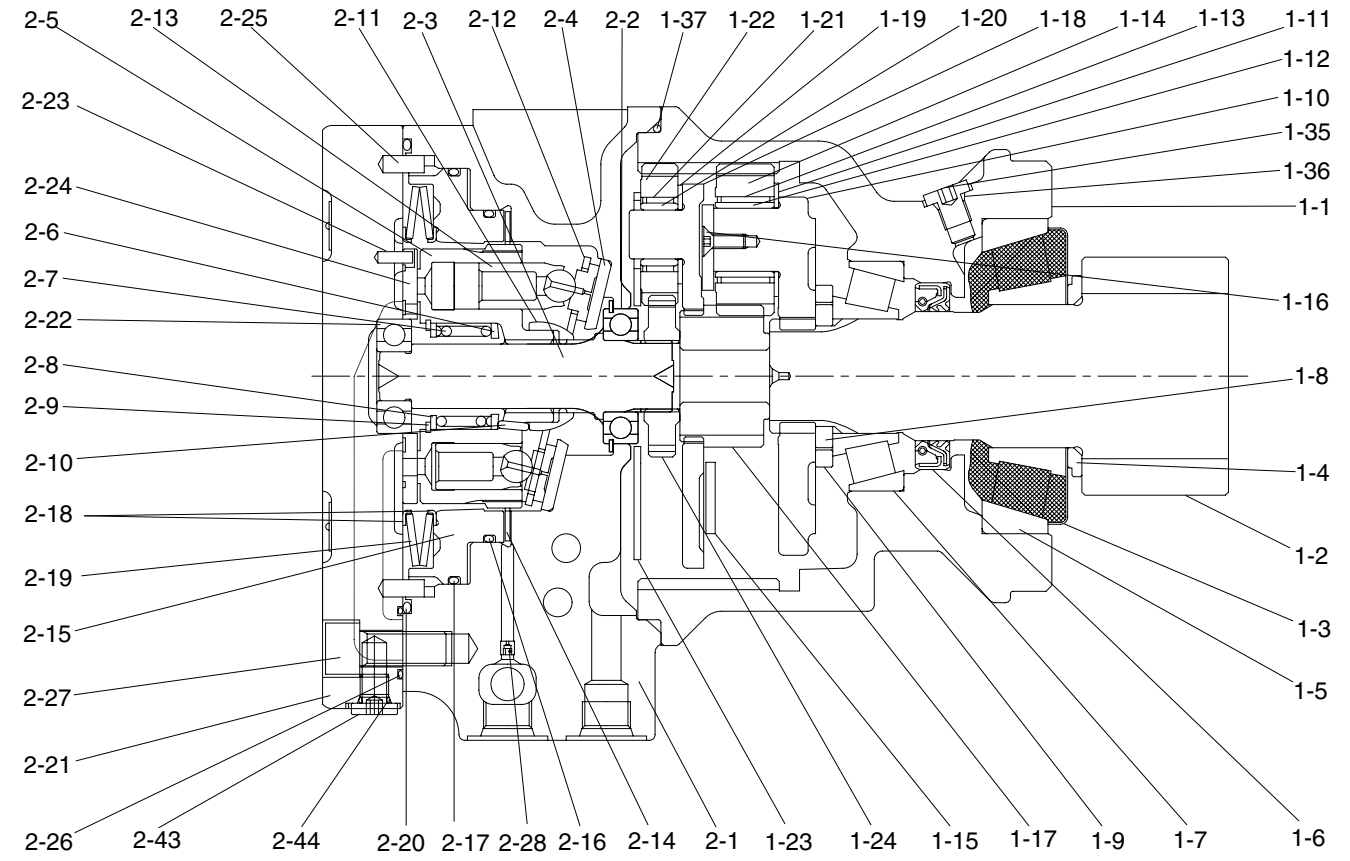
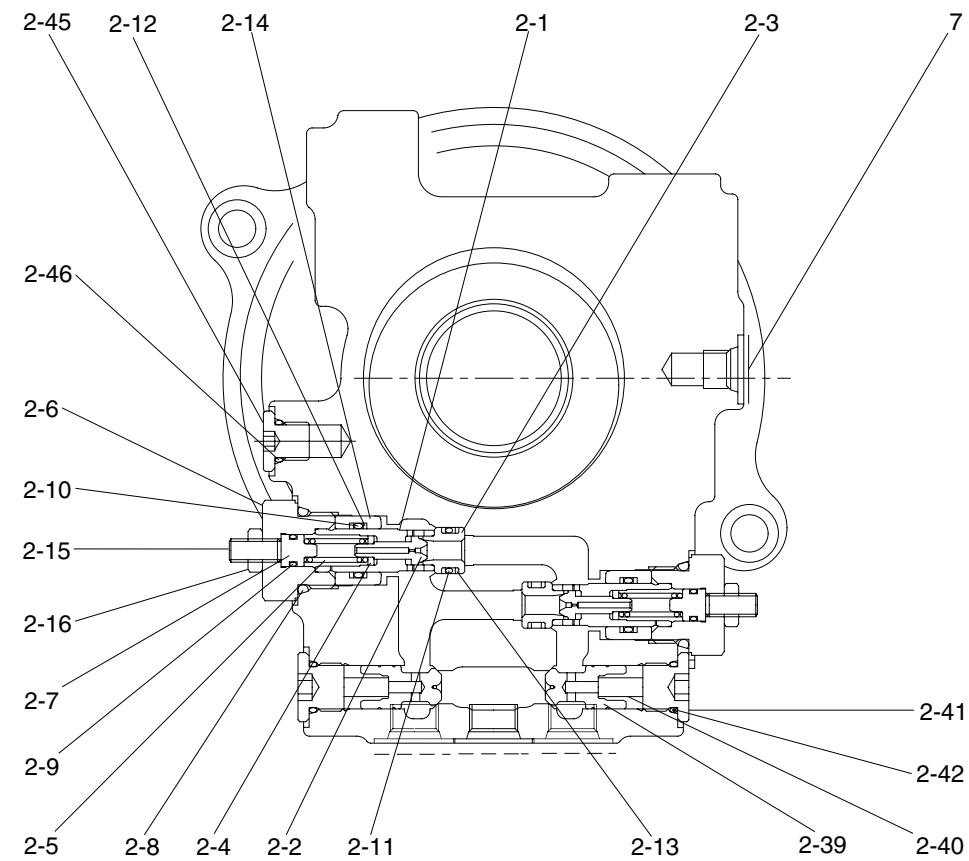

1 Gear box	1-11 Thrust washer	1-22 Planetary gear	2-5 Cylinder block	2-16 O-ring	2-27 Socket head bolt
1-1 Housing	1-12 Inner race	1-23 Thrust plate	2-6 Collar	2-17 O-ring	2-28 Orifice
1-2 Pinion shaft	1-13 Needle bearing	1-24 Drive gear	2-7 Spring	2-18 Spring seat	2-38 Relief valve assy
1-3 Plate	1-14 Planetary gear B	1-35 Plug	2-8 Washer	2-19 Spring	2-39 Check valve
1-4 Collar	1-15 Thrust plate	1-36 O-ring	2-9 Snap ring	2-20 O-ring	2-40 Spring
1-5 Tapper roller bearing	1-16 Screw	1-37 O-ring	2-10 Pin	2-21 Cover	2-41 Plug
1-6 Oil seal	1-17 Sun gear B	2 Axial motor piston	2-11 Retainer holder	2-22 Ball bearing	2-42 O-ring
1-7 Tapper roller bearing	1-18 Holder	2-1 Case	2-12 Retainer plate	2-23 Pin	2-43 Plug
1-8 Plate	1-19 Thrust washer	2-2 Ball bearing	2-13 Piston assy	2-24 Valve plate	2-44 O-ring
1-9 Collar	1-20 Inner race	2-3 Shaft	2-14 Disc	2-25 Pin	2-45 Plug
1-10 Holder	1-21 Needle bearing	2-4 Thrust plate	2-15 Brake piston	2-26 O-ring	2-46 O-ring

R35Z72SM12

2) DISASSEMBLY

Disassemble the parts by the following procedure.

(1) Separating the motor and the reduction gear

Secure the motor assembly in a vice and remove the socket head bolt (3).

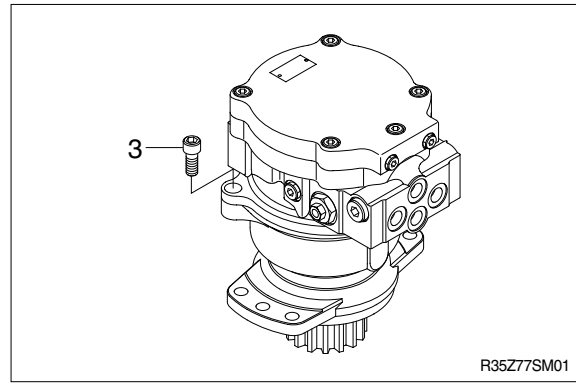

(2) Disassembling the motor

① Secure the motor assembly in a vice.
Remove the socket head bolts (2-27) and separate the cover (2-21).

※ When separating the cover (2-21), be careful not to drop the valve plate (2-24).

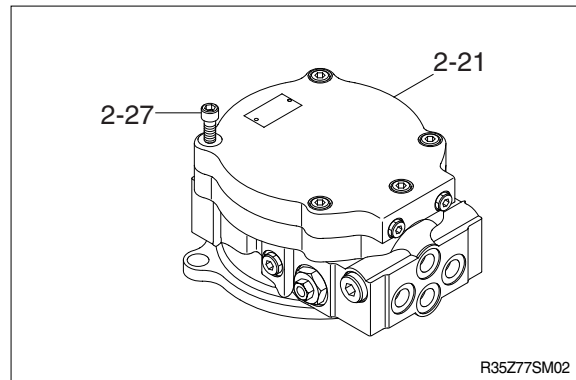

② Remove the valve plate (2-24) and the pin (2-23).

※ The valve plate (2-24) may remain on the motor side.

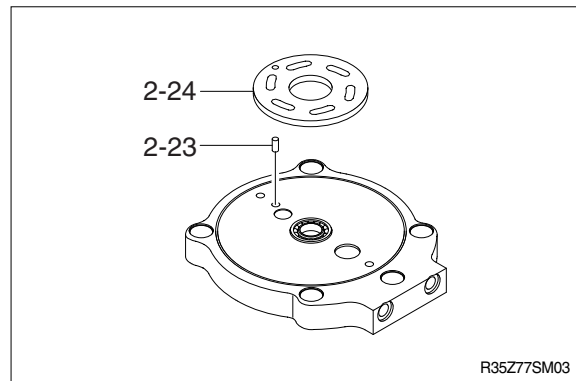

③ Remove the bearing (2-22). Remove the O-ring (2-26).

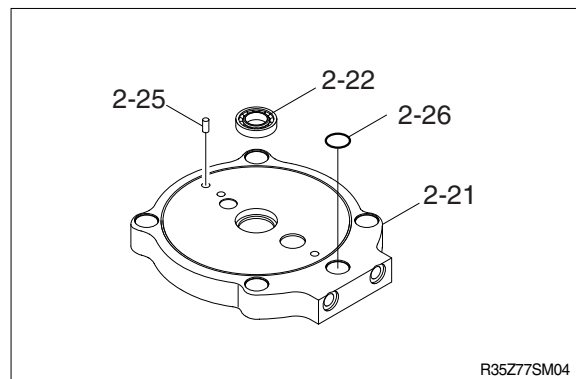

④ Disassemble the check valve.

- a. Loosen to remove the plug (2-41).

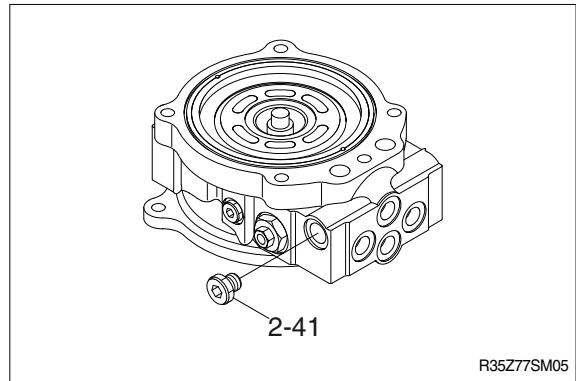

- b. Remove the spring (2-40) and the check valve (2-39).

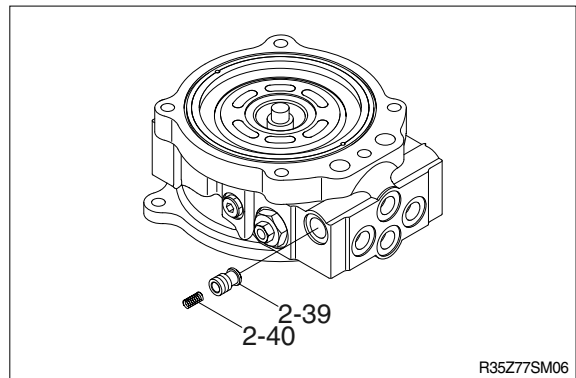

⑤ Remove the relief valve.

- a. Loosen the plug (2-38-6) to remove the relief valve assembly (2-38).

- ※ Do not move the adjuster kit (2-38-7). Otherwise, the set pressure will change.
- ※ Do not disassemble the relief valve assembly (2-38) because it is a functional component.

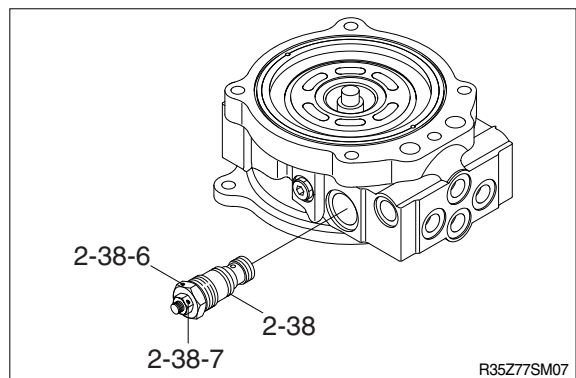

- ⑥ Remove the disc spring assembly (2-19) and the spring seat (2-18), and utilizing the gage port of the case (2-1), remove the parking brake piston (2-15).

- ※ The piston may be ejected by the air pressure. Exercise sufficient care during removal. At the beginning of the work, set a lower air pressure and adjust it while checking the piston for ejection.

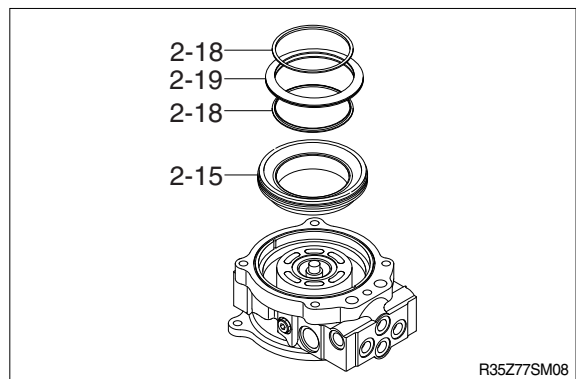

- ⑦ Remove the cylinder block and other associated parts.

(2-5) Cylinder block

(2-6) Collar

(2-7) Spring

(2-8) Washer

(2-9) Snap ring

(2-10) Pin

(2-11) Retainer holder

(2-12) Retainer plate

(2-13) Piston assembly

(2-14) Disc(Parking brake spec. only)

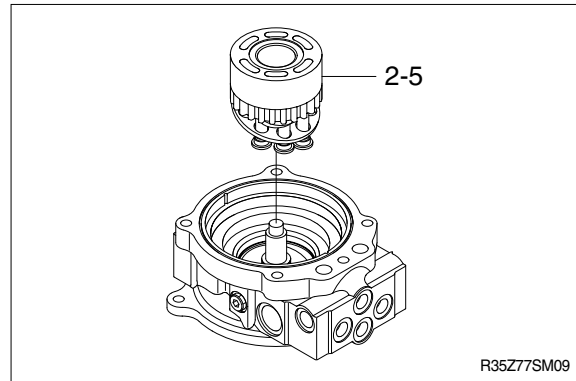

- ⑧ Remove the retainer plate (2-12) and the piston assembly (2-13).

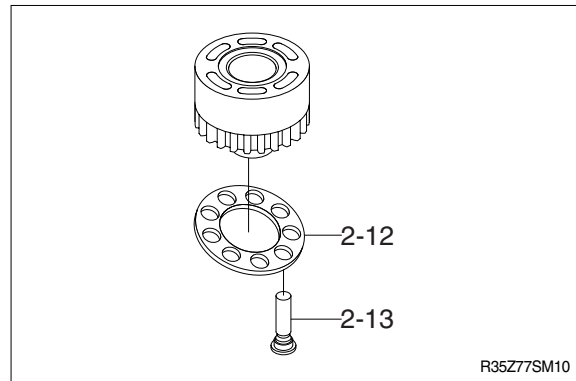

- ⑨ Remove the pin (2-10) and the retainer holder (2-11).

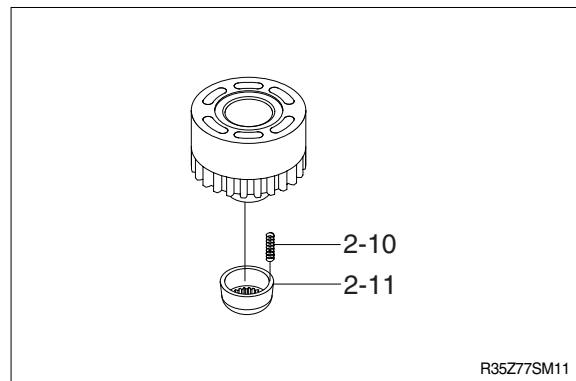

- ⑩ While pushing the washer (2-8), remove the snap ring (2-9).

- ⑪ Remove the collar (2-6), the spring (2-7) and the washer (2-8).

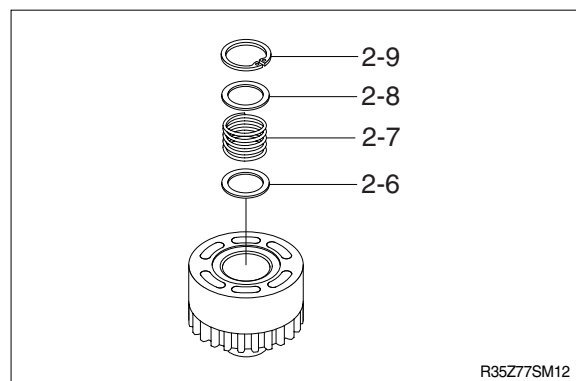

⑫ Remove the thrust plate (2-4).

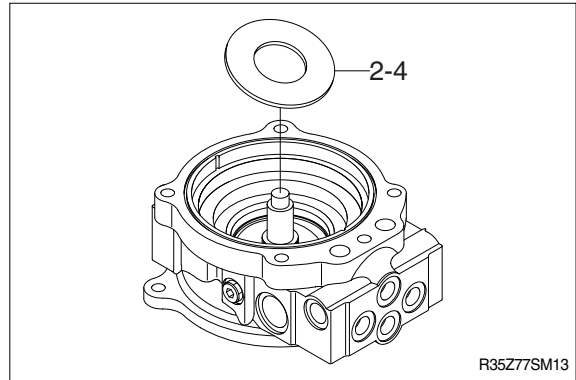

⑬ Lightly strike the end of the shaft (2-3) with a plastic hammer to remove the shaft.

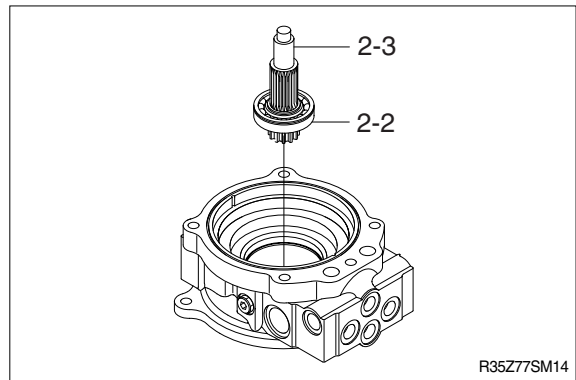

⑭ Disassemble the bearing (2-2) and the ball bearing (2-3).

※ The disassembled bearing must not be used.

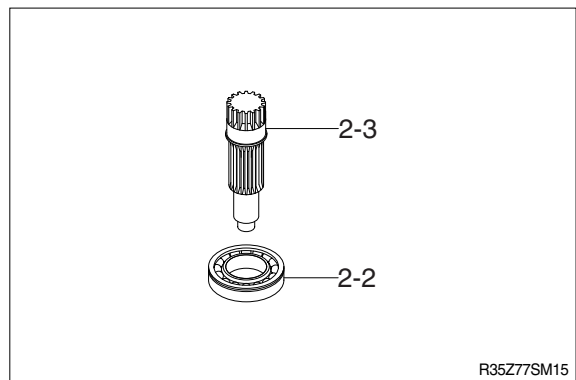

(3) Disassembling the reduction gear

① Remove the following parts.

- (1-37) O-ring
- (1-23) Thrust plate
- (1-24) Drive gear
- (1-22) Planetary gear
- (1-21) Needle bearing
- (1-20) Inner race
- (1-19) Thrust washer
- (1-18) Holder

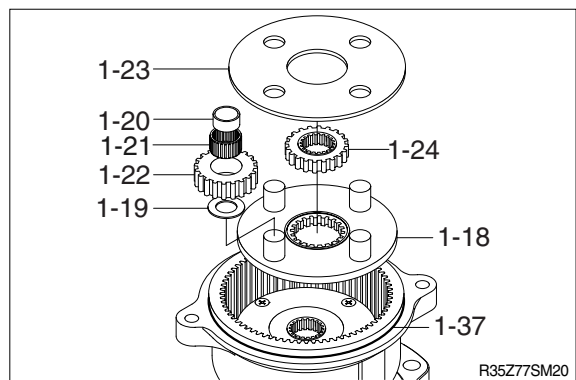

- ② Remove the sun gear (1-17).

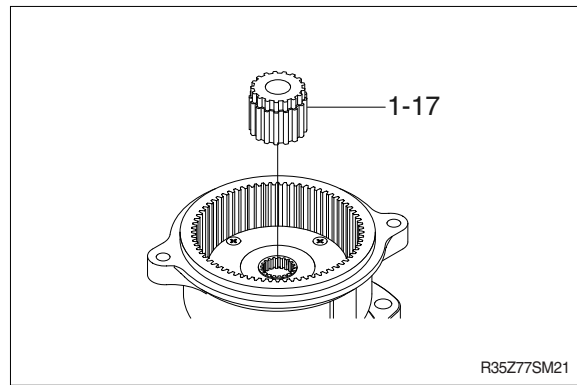

- ③ Remove the holder (1-11) and other associated parts.

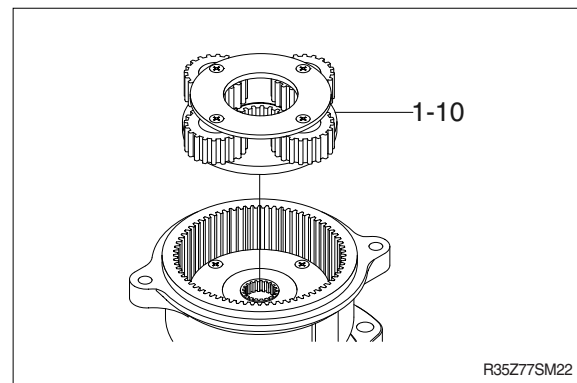

- ☐ Secure the holder (1-11) in a vice and loosen the screw (1-16) to remove the thrust plate (1-15).

- ※ The screw is hard to remove because loctite was used during assembly. To facilitate the removal of the screw, warm the screw with a drier.

- ⑤ Remove the following parts.

- (1-14) Planetary gear
- (1-13) Needle bearing
- (1-12) Inner race

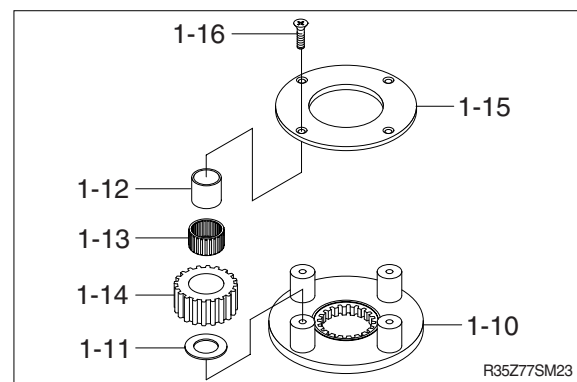

- ※ When replacing the taper roller bearings (1-6) and (1-8), the collar (1-3) and the plate (1-4), they are to be replaced by the body assembly.

- ⑥ Remove the following parts.

- (1-9) Plate
- (1-10) Collar

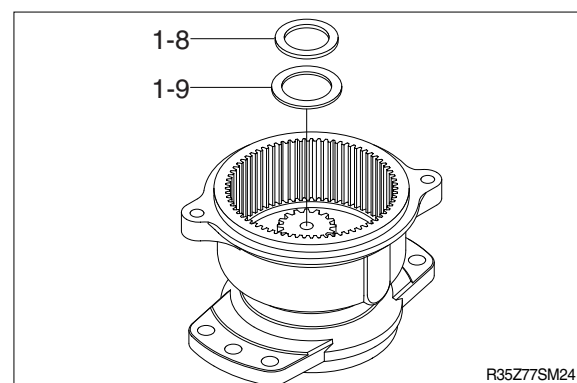

⑦ Remove the pinion shaft (1-2)

- ※ When removing the shaft, be careful not to drop it. If it is hard to remove, lightly strike it with a plastic hammer.

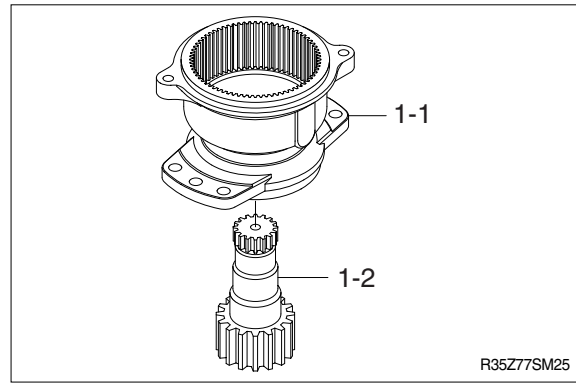

⑧ Remove the inner race of the taper roller bearing (1-7).

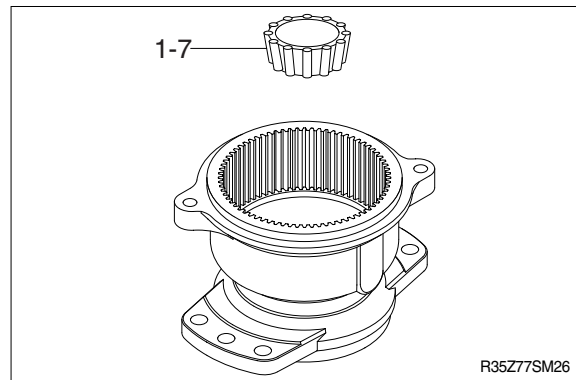

⑨ Break the oil seal (1-6) to remove it.

- ※ The removed oil seal must not be used again.
- When removing it, exercise care to prevent damage to the outer races of the taper roller bearing (1-8) and (1-6).

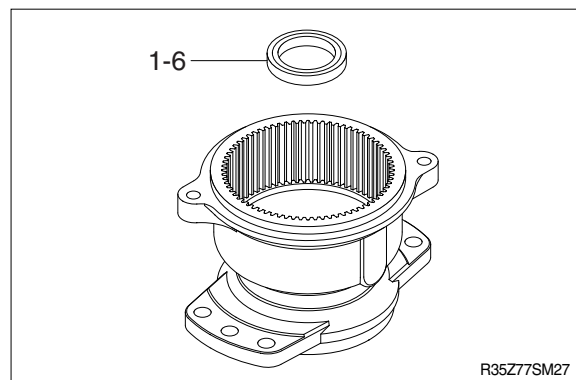

⑩ Remove the outer race of the taper roller bearing (1-8) and the plug (1-35).

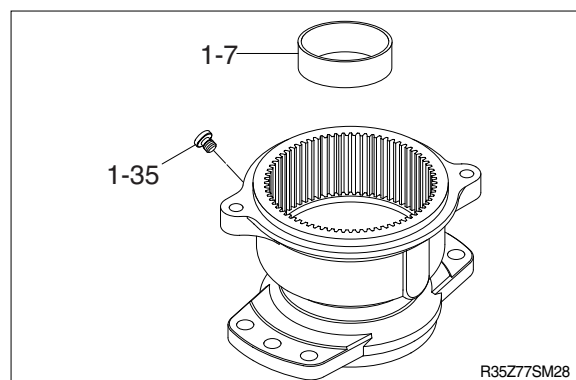

3) ASSEMBLY

Assemble the parts by the following procedure.

(1) Assembling the motor

① Install the relief valve assembly (2-38).

- Tightening torque : $157 \pm 10 \text{ N} \cdot \text{m}$
 $161 \pm 1 \text{ kgf} \cdot \text{m}$

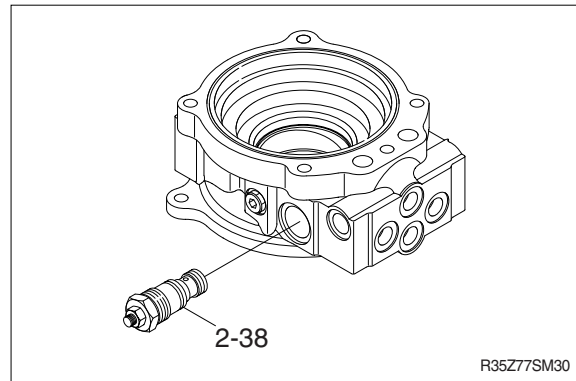

② Assemble the check valve (2-39) and the spring (2-40).

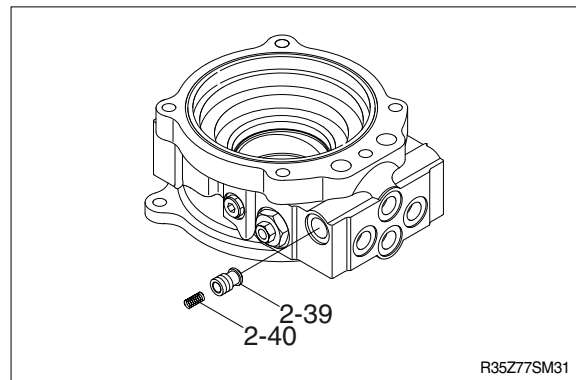

③ Install the plug (2-41).

- Tightening torque : $39.2 \pm 2.0 \text{ N} \cdot \text{m}$
 $4.0 \pm 0.2 \text{ kgf} \cdot \text{m}$

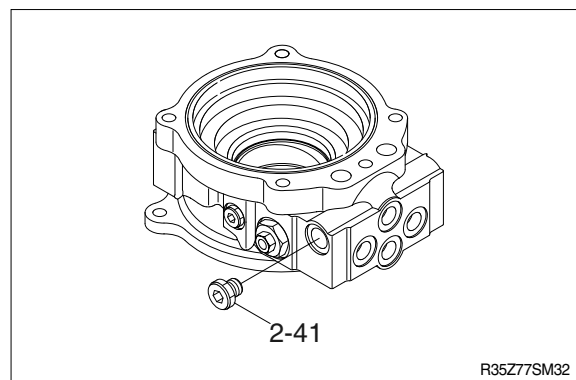

④ Assemble the collar (2-6), the spring (2-7) and the washer (2-8) in the cylinder block (2-5).

※ Be sure to assemble the collar (2-6) in the correct direction.

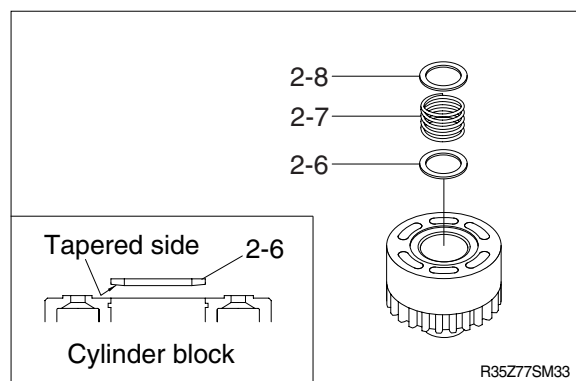

- ⑤ While pushing the washer (2-8), assemble the snap ring (2-9).

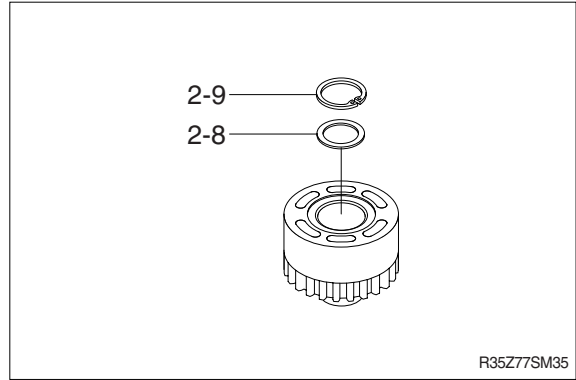

- ⑥ Apply grease to the pin (2-10) and assemble it in the cylinder block (2-5).
- ⑦ Assemble the retainer holder (2-11).

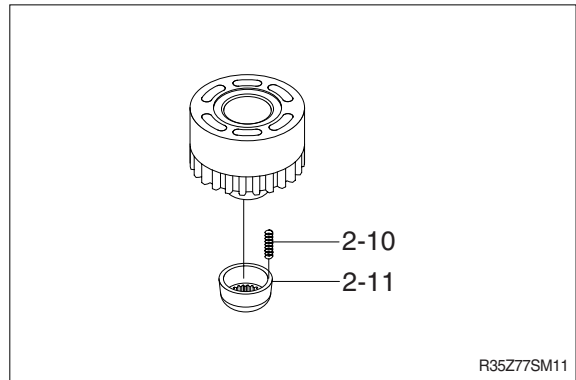

- ⑧ Set the piston assembly (2-13) on the retainer plate (2-12) and assemble it in the cylinder block (2-5).
- ※ Apply an ample amount of hydraulic fluid to the sliding part before assembly.

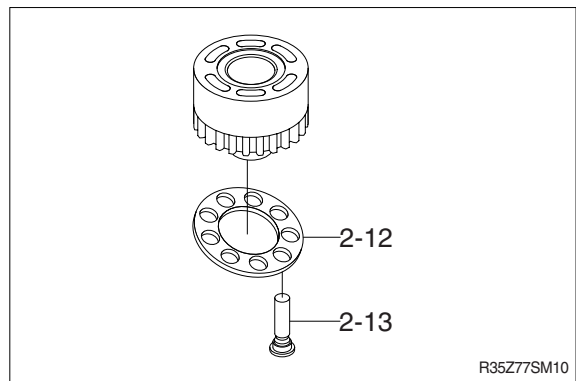

- ⑨ Press-fit the ball bearing (2-2) on the shaft (2-3).
- ※ Press-fit the ball bearing (2-2) with the attached snap ring facing as shown in the figure.

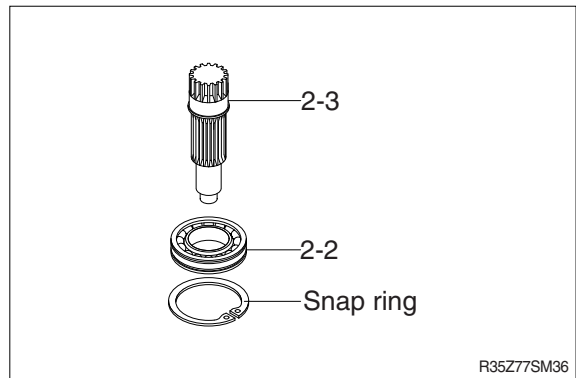

- ⑩ Press-fit the shaft (2-3) and the ball bearing (2-2) in the case (2-1).

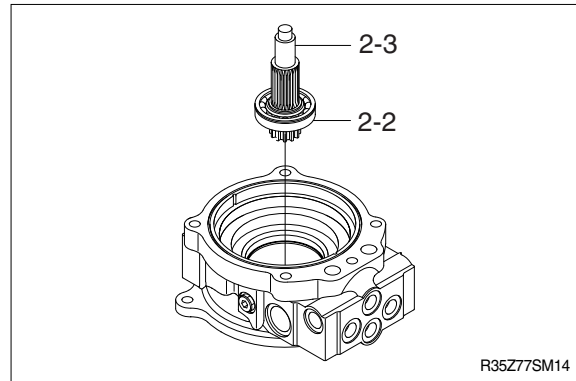

- ⑪ Apply grease to the back side of the thrust plate (2-4) and assemble it.

- ※ The thrust plate must be assembled in the correct direction.

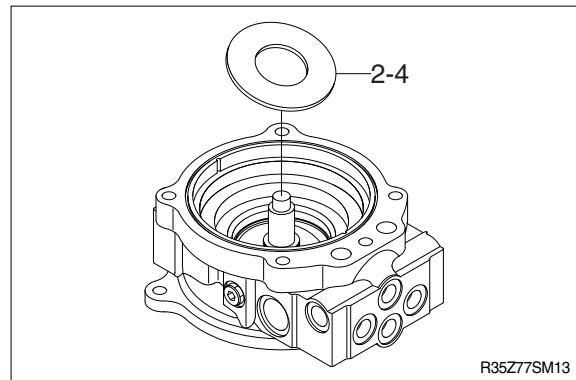

- ⑫ Assemble the cylinder block (2-5) and other associated parts.

- ※ During assembly, be sure that the pin (2-10) will not come out.

- ※ The disk(2-14) is assembled only for the parking brake spec only.

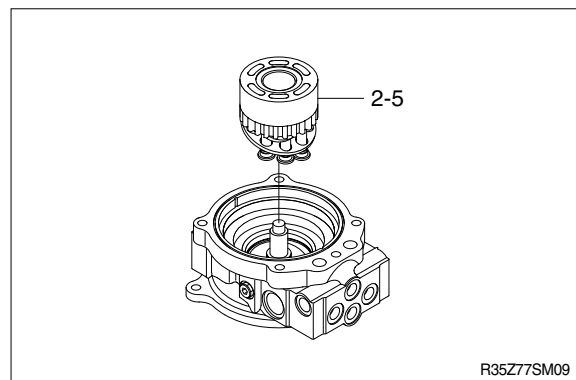

- ⑬ Apply grease to the O-ring (2-16) and the O-ring (2-17) and assemble them on the brake piston (2-15).

- ⑭ While paying attention to the location of the hole of the pin (2-25), assemble the brake piston (2-15) in the case (2-1).

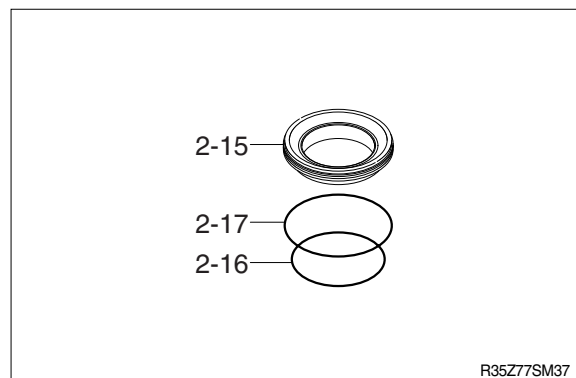

- ⑮ Assemble the spring seat (2-19) and the disc spring assembly (2-18) in the correct direction.

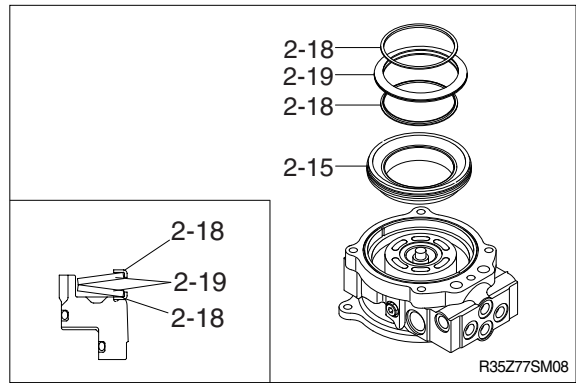

- § Apply grease to the O-ring (2-20) and assemble it in the case (2-1).
Check to see if the pin (2-25) can be assembled in the brake piston and case hole. If not, remove the brake piston (2-15) and re-orient it, then reassemble.

- ※ Assemble the pin (2-25) while being attached on the cover.

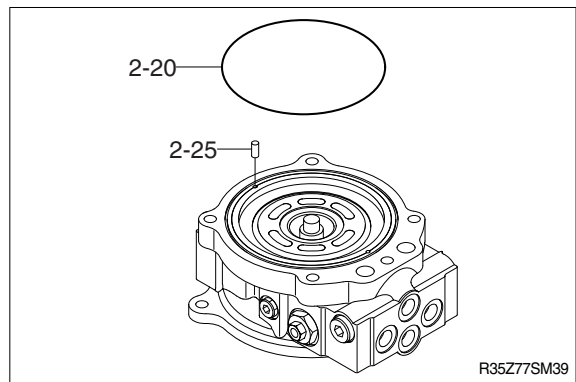

- §æ Apply grease to the O-ring (2-26) and the pin (2-25), then assemble them in the cover (2-21).
Press-fit the ball bearing (2-22).

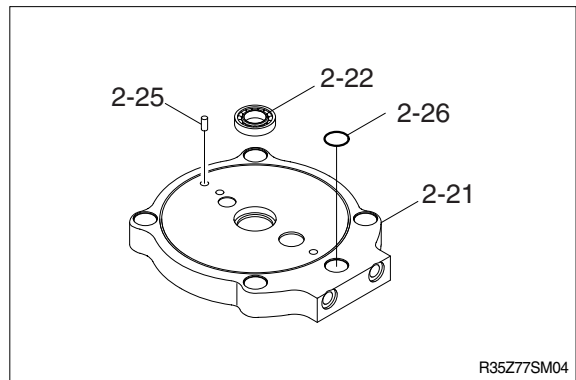

- § Install the pin (2-23), then install the valve plate (2-24).
To prevent it from falling, apply grease to the back side.

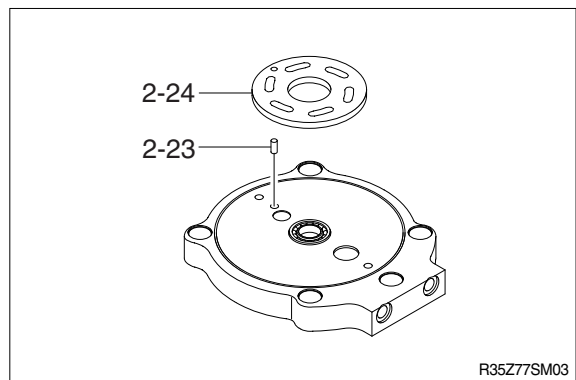

§ While paying attention to the location of the pin (2-25), install the cover (2-21) and other associated parts to the case (2-1).

※ Exercise care so that the pin (2-25) and the valve plate (2-24) will not fall.

§ Loosely tighten the socket head bolts (2-27), then using a torque wrench, tighten them to the specified torque.

- Tightening torque : $13 \pm 0.7 \text{ kgf} \cdot \text{m}$
($94.4 \pm 5 \text{ lbf} \cdot \text{ft}$)

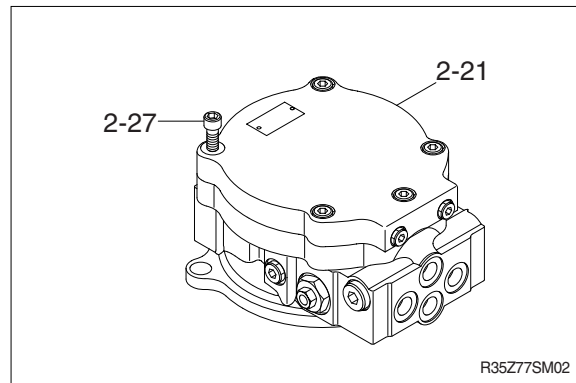

(2) Assembling the reduction gear

① Press-fit the oil seal (1-7).

※ Prior to press-fit, apply grease to the oil seal mounting area of the housing and the periphery of the oil seal.

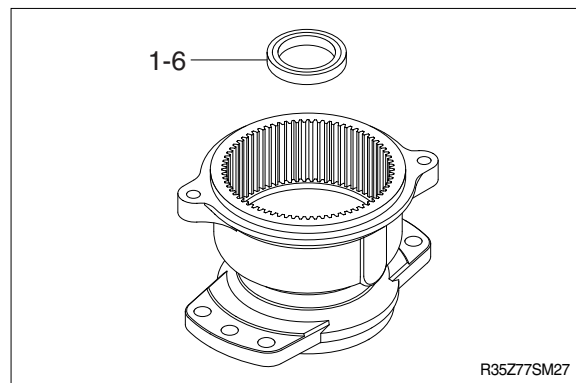

② Press-fit the taper roller bearing (1-8) and install the plug (1-35).

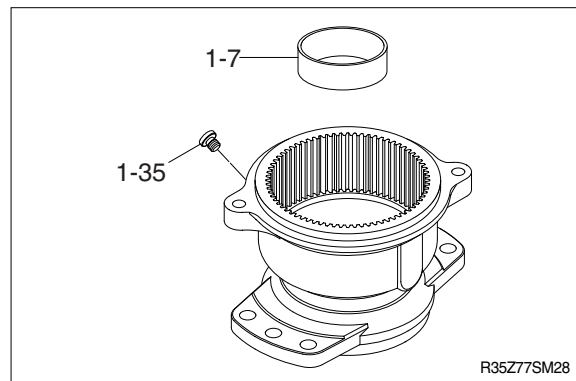

③ Apply grease to the inner race of the taper roller bearing (1-6) assembled on the pinion shaft (1-2).

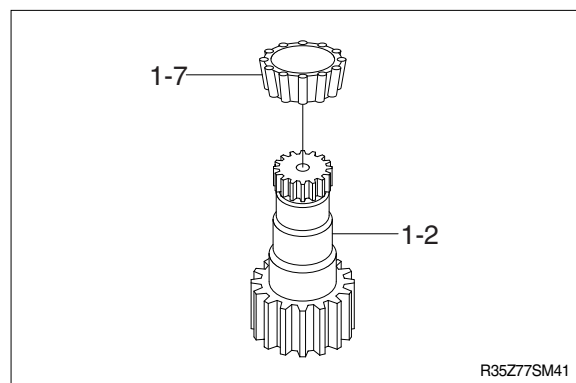

- ④ Install the pinion shaft (1-2) and other associated parts. Install the taper roller bearing inner race (1-7).

※ Prior to assembling the pinion shaft (1-2), etc. apply grease to the lip of the oil seal (1-6).

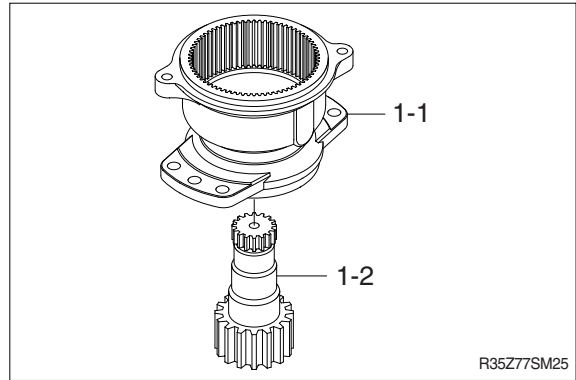

- ⑤ Install the collar (1-9) and the plate (1-8).

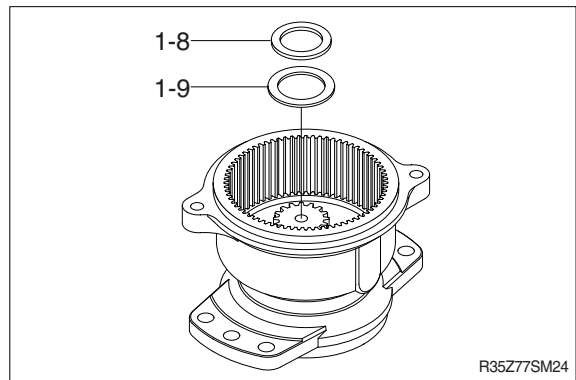

- ⑥ Install the following parts on the holder (1-10).

- (1-11) Thrust washer
- (1-12) Inner race
- (1-13) Needle bearing
- (1-14) Planetary gear B
- (1-15) Thrust plate
- (1-16) Screw

※ Apply loctite 242 to the screw prior to tightening it.

· Tightening torque : $0.4 \pm 0.05 \text{ kgf}_i / \text{m}$
 $2.9 \pm 0.3 \text{ lbf}_i / \text{ft}$

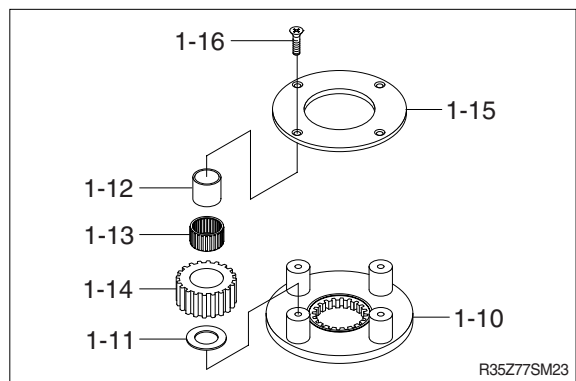

- ⑧ Install the holder (1-10) and other associated parts.

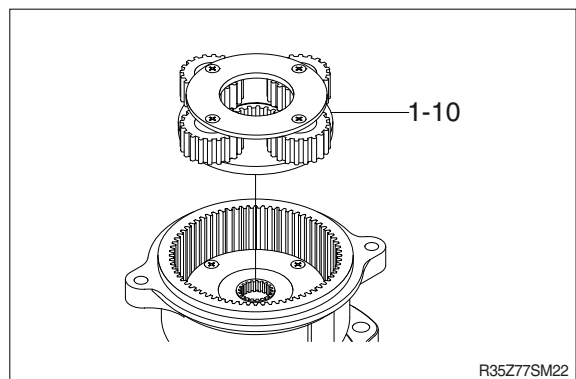

- ⑨ Install the sun gear (1-17).
 ※ Install the sun gear (1-17) with the snap facing as shown in the figure.

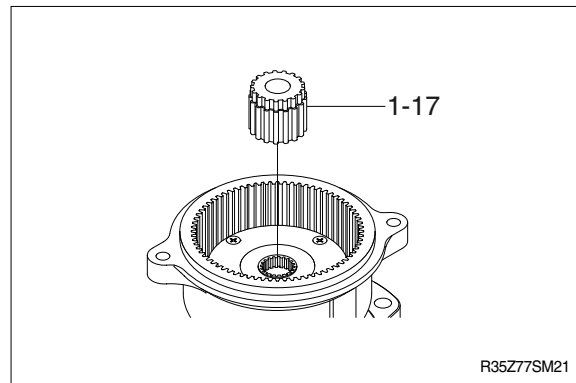

- ⑩ Install the holder (1-18).

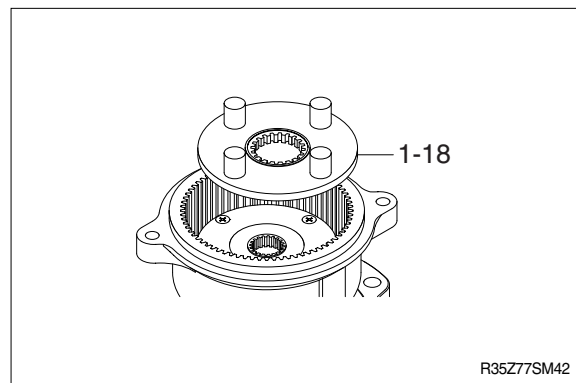

- ⑪ Install the following parts.
 (1-19) Thrust washer
 (1-20) Inner race
 (1-21) Needle bearing
 (1-22) Planetary gear A
 (1-23) Thrust plate
 (1-24) Drive gear
 (1-37) O-ring

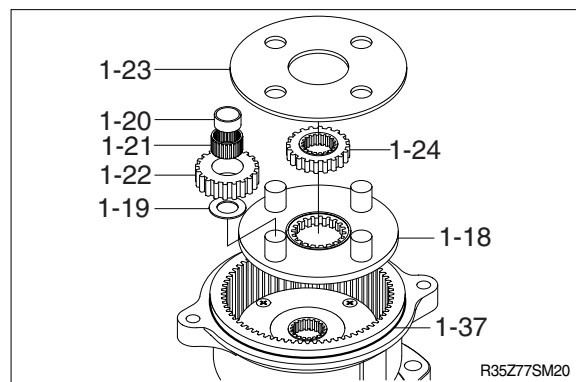

- ※ Selection for thrust plate (15).
 When any consisting parts of reduction unit were changed, select and install thrust plate corresponding to the measured value "E" referring to the below table.

E dimension (measured value)	Less than 6.6	6.6~7.2	More than 7.2
Part no. of thrust plate 1-23 (plate thickness)	XJBV-00129 (3.2 mm)	XJBV-00130 (2.8 mm)	XJBV-00131 (2.3 mm)

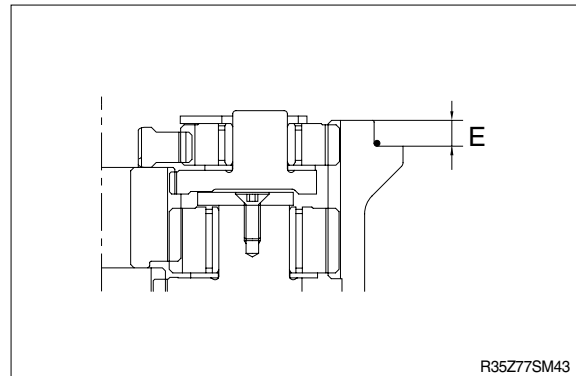

(3) Assembling the whole motor assembly

Place the reduction gear assembly on the motor assembly and loosely tighten the socket head bolt (3), then tighten it to the specified torque.

- Tightening torque : $13 \pm 0.7 \text{ kgf} \cdot \text{m}$
($94.4 \pm 5 \text{ lbf} \cdot \text{ft}$)

