

GROUP 2 ENGINE SYSTEM

1. ENGINE AND ACCESSORIES MOUNTING

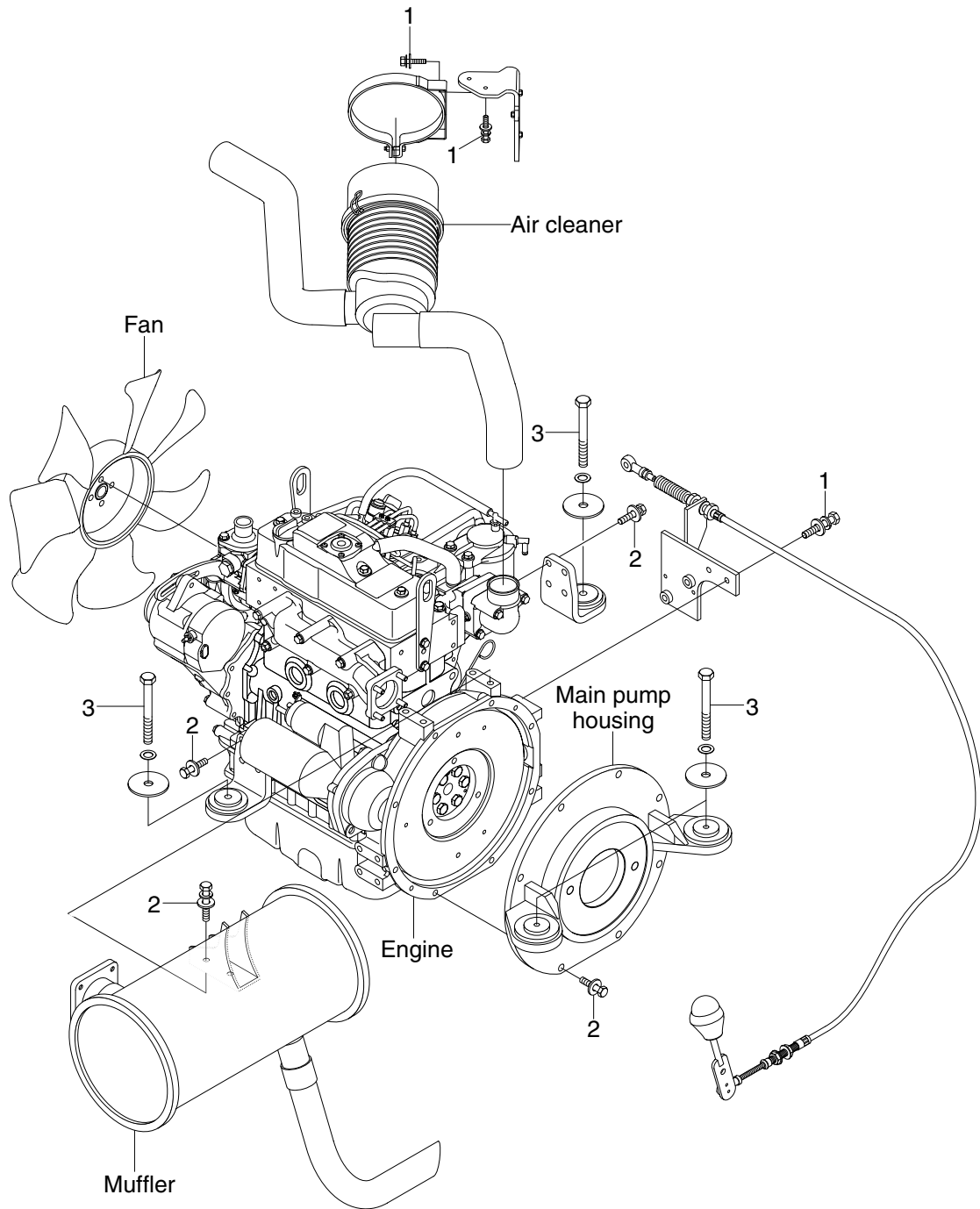

R35Z78CM01

· Tightening torque

Item	Size	kgf · m	lbf · ft
1	M 8×1.25	2.5±0.5	18.1±3.6
2	M10×1.5	6.9±1.4	49.9±10.1

Item	Size	kgf · m	lbf · ft
3	M16×2.0	25±2.5	181±18.1

2. COOLING SYSTEM AND FUEL TANK MOUNTING

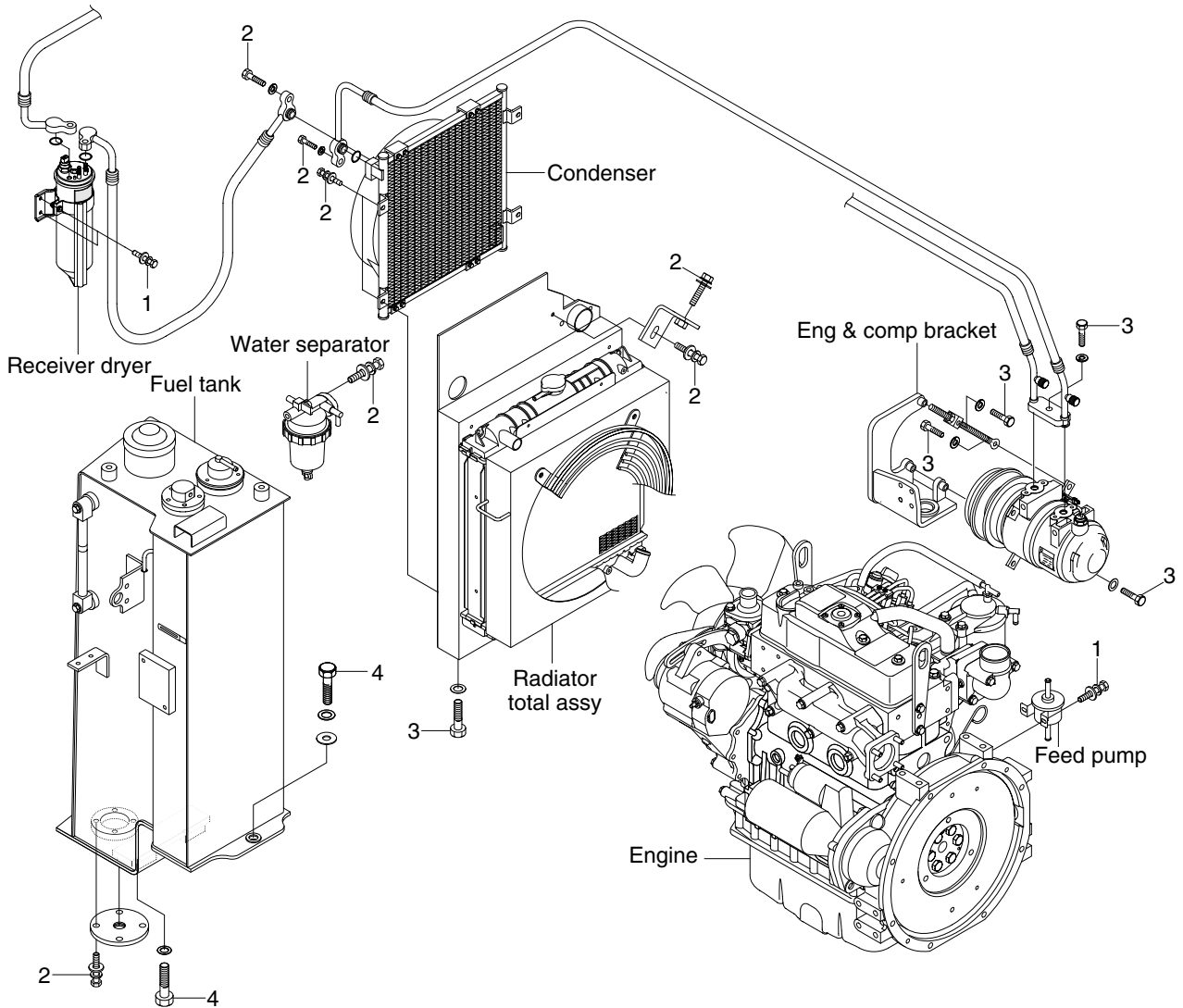

R35Z78CM02

· Tightening torque

Item	Size	kgf · m	lbf · ft
1	M 6×1.0	1.05±0.2	7.6±1.45
2	M 8×1.25	2.5±0.5	18.1±3.6

Item	Size	kgf · m	lbf · ft
3	M 10×1.25	6.9±1.4	49.9±10.1
4	M 12×1.75	12.8±3.0	92.6±21.7