

SECTION 5 MECHATRONICS SYSTEM

Group 1 Outline	5-1
Group 2 Mode Selection System	5-3
Group 3 Automatic Deceleration System	5-6
Group 4 Power Boost System	5-7
Group 5 Travel Speed Control System	5-8
Group 6 Automatic Warming Up Function	5-9
Group 7 Engine Overheat Prevention Function	5-10
Group 8 Anti-Restart System	5-11
Group 9 Self-Diagnostic System	5-12
Group 10 Engine Control System	5-15
Group 11 EPPR(Electro Proportional Pressure Reducing) Valve	5-21
Group 12 Prolix System	5-24
Group 13 Monitoring System	5-25

SECTION 5 MECHATRONICS SYSTEM

GROUP 1 OUTLINE

The NEW CAPO(Computer Aided Power Optimization) system controls engine and pump mutual power at an optimum and less fuel consuming state for the selected work by mode selection, auto-deceleration, power boost function, etc. It monitors machine conditions, for instance, engine speed, coolant temperature, hydraulic oil temperature, and hydraulic oil pressure, etc.

It consists for a CPU controller, a cluster, an accel actuator, an EPPR valve, and other components. The CPU controller and the cluster protect themselves from over-current and high voltage input, and diagnose malfunctions caused by short or open circuit in electric system, and display error codes on the cluster.

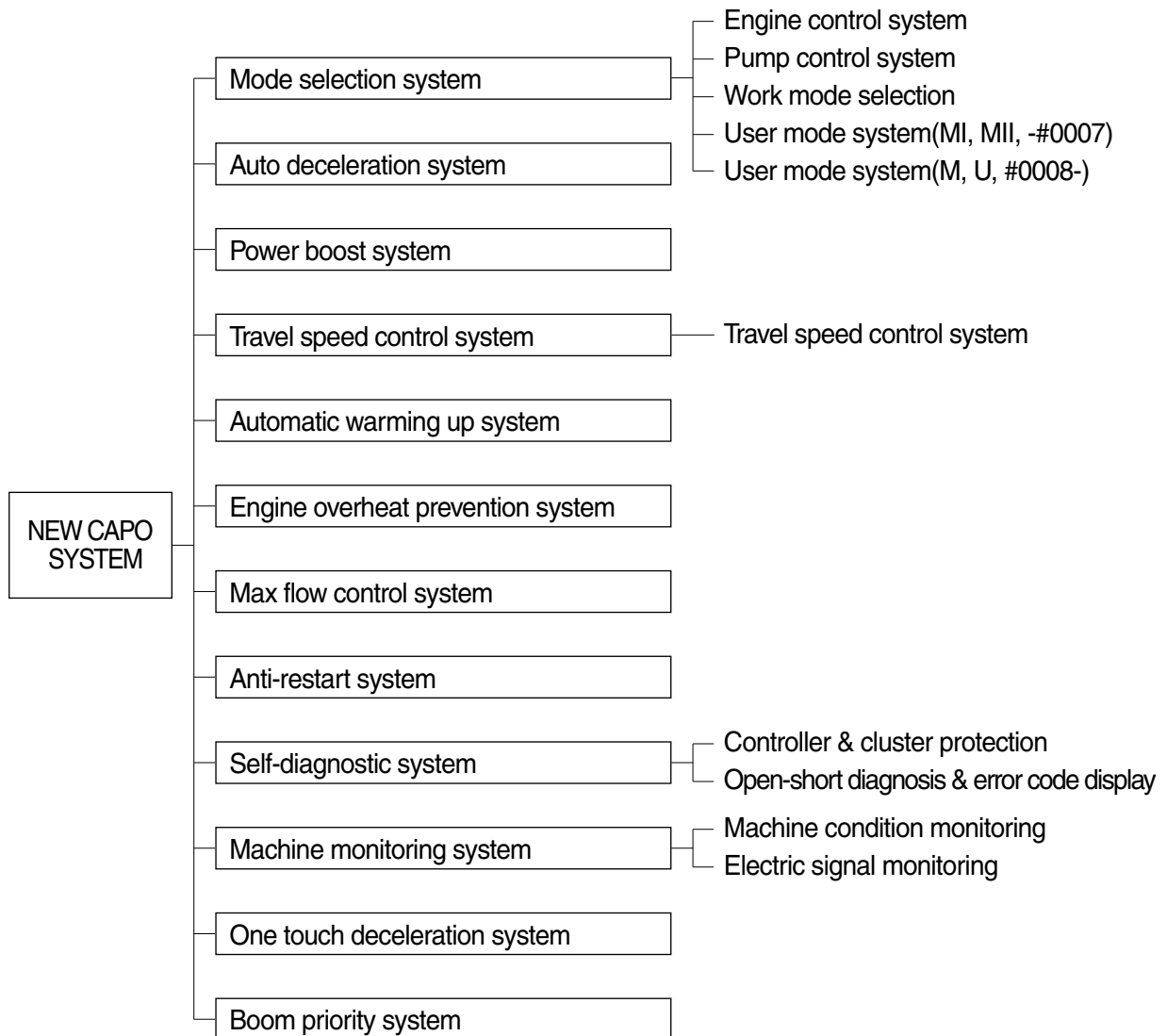

SYSTEM DIAGRAM(-#0007)

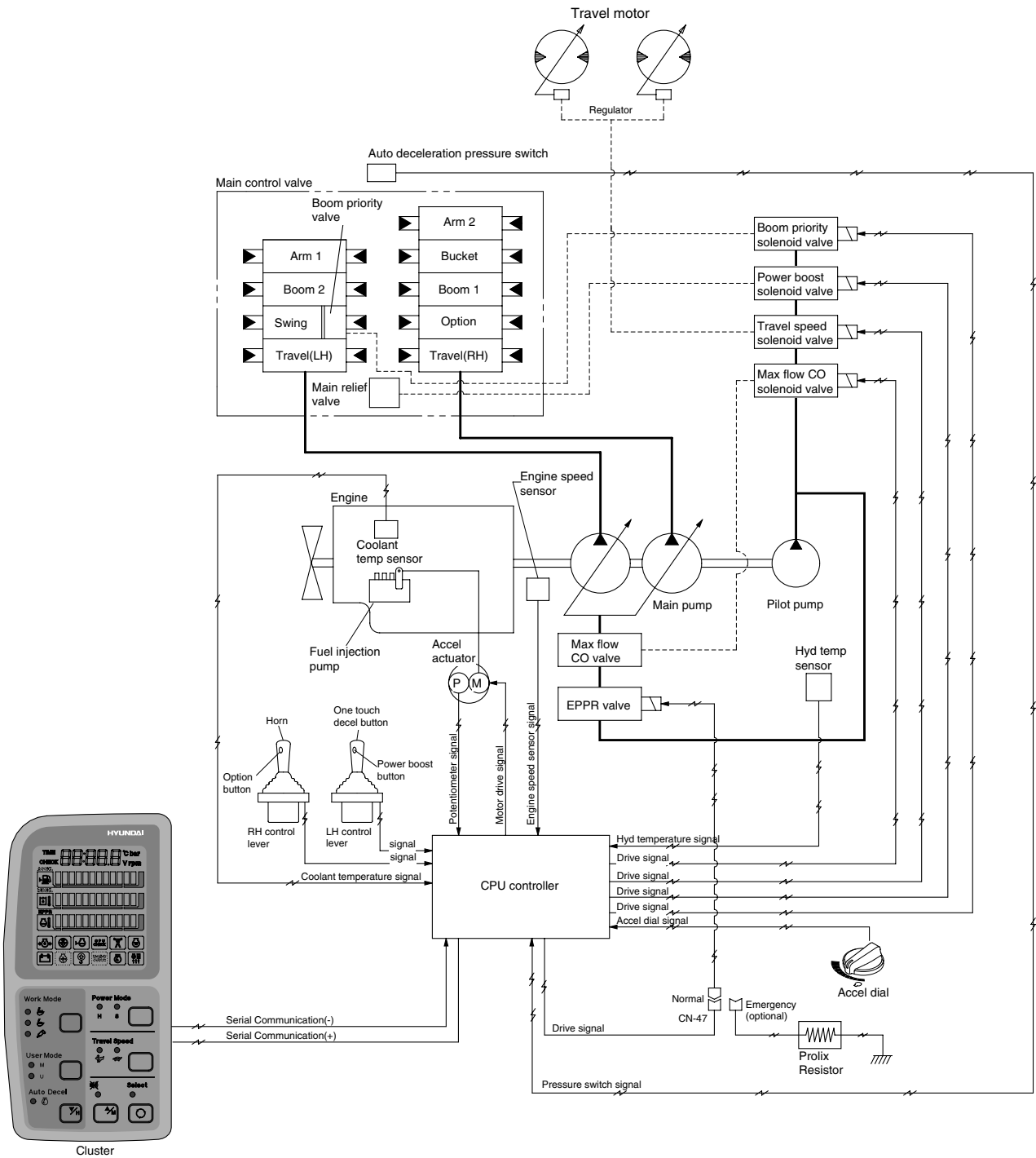

34075MS08

SYSTEM DIAGRAM(#0008-)

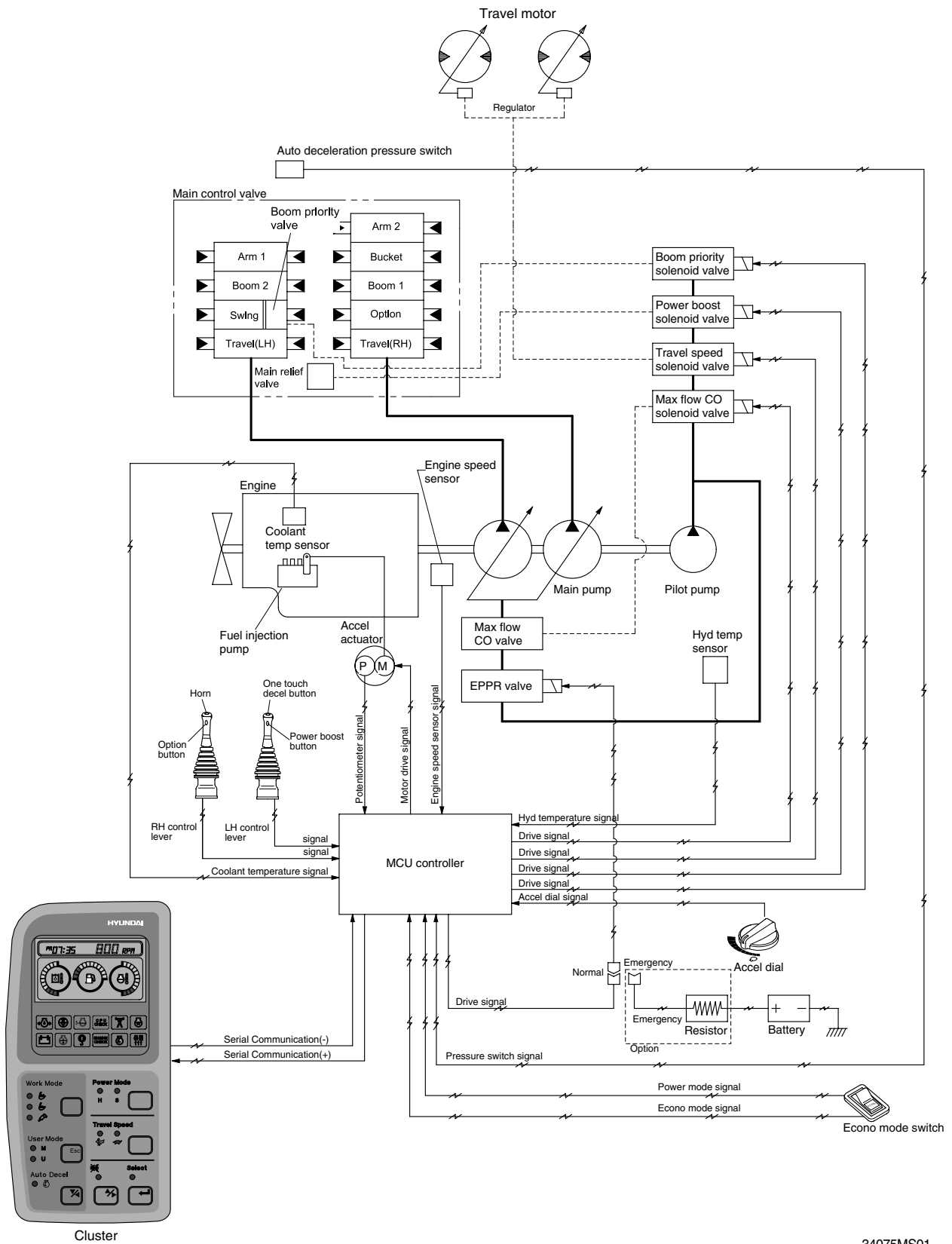

GROUP 2 MODE SELECTION SYSTEM(-#0007)

1. POWER MODE SELECTION SYSTEM

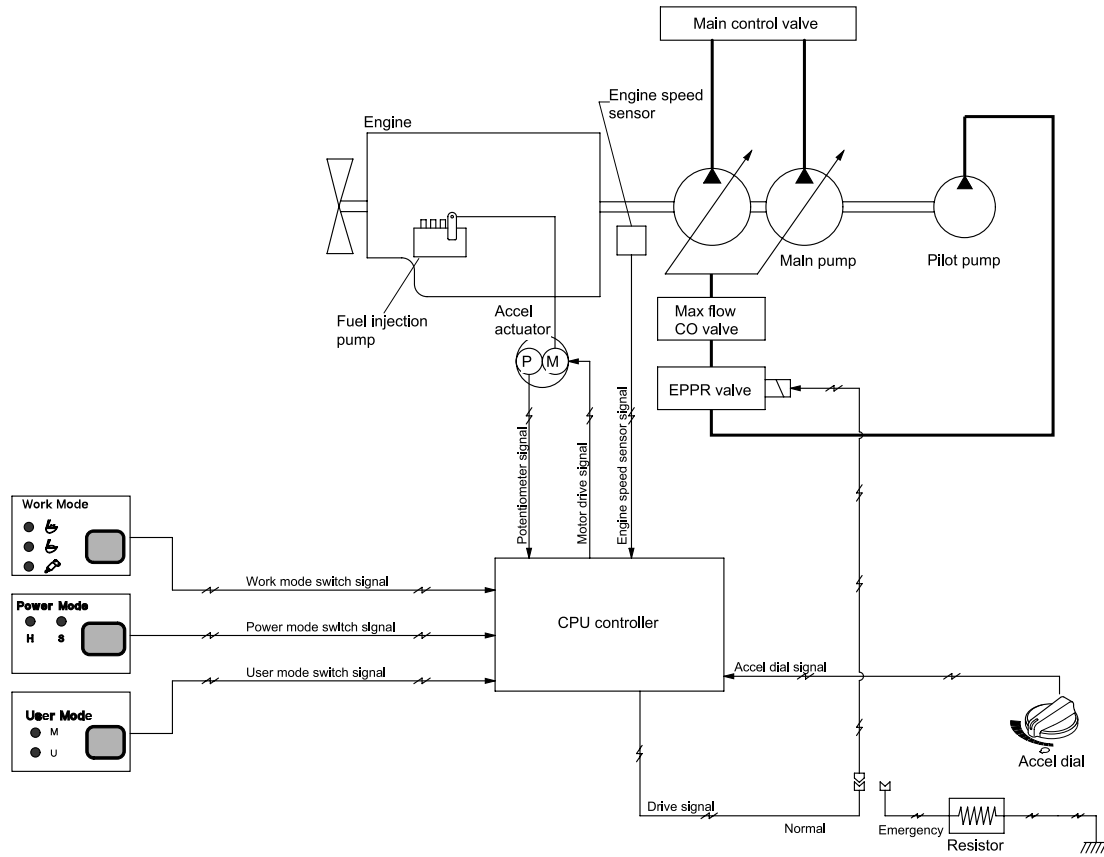

34075MS09

Mode selection system(Micro computer based electro-hydraulic pump and engine mutual control system) optimizes the engine and pump performance.

The combination of 2 power modes(H, S) and accel dial position(10 set) makes it possible to use the engine and pump power more effectively corresponding to the work conditions from a heavy and great power requesting work to a light and precise work.

Mode	Application	Power set (%)	Engine rpm		Power shift by EPPR valve			
			Unload	Load	Default		Other case	
					Current (mA)	Pressure (kgf/cm ²)	Current (mA)	Pressure (kgf/cm ²)
M	Maximum Power	95	1900 ± 50	1750	305 ± 30	9	250	5
H	High power	85	1800 ± 50	1650	360 ± 30	12	280	7
S	Standard power	70	1700 ± 50	1550	360 ± 30	12	280	7
AUTO DECEL	Engine deceleration	-	1000 ± 100	-	700 ± 30	35	700 ± 30	35
One touch decel	Engine quick deceleration	-	900 ± 100	-	700 ± 30	35	700 ± 30	35
KEY START	Key switch start position	-	900 ± 100	-	700 ± 30	35	700 ± 30	35

2. WORK MODE SELECTION SYSTEM

3 work modes can be selected for the optional work speed of the machine operation.

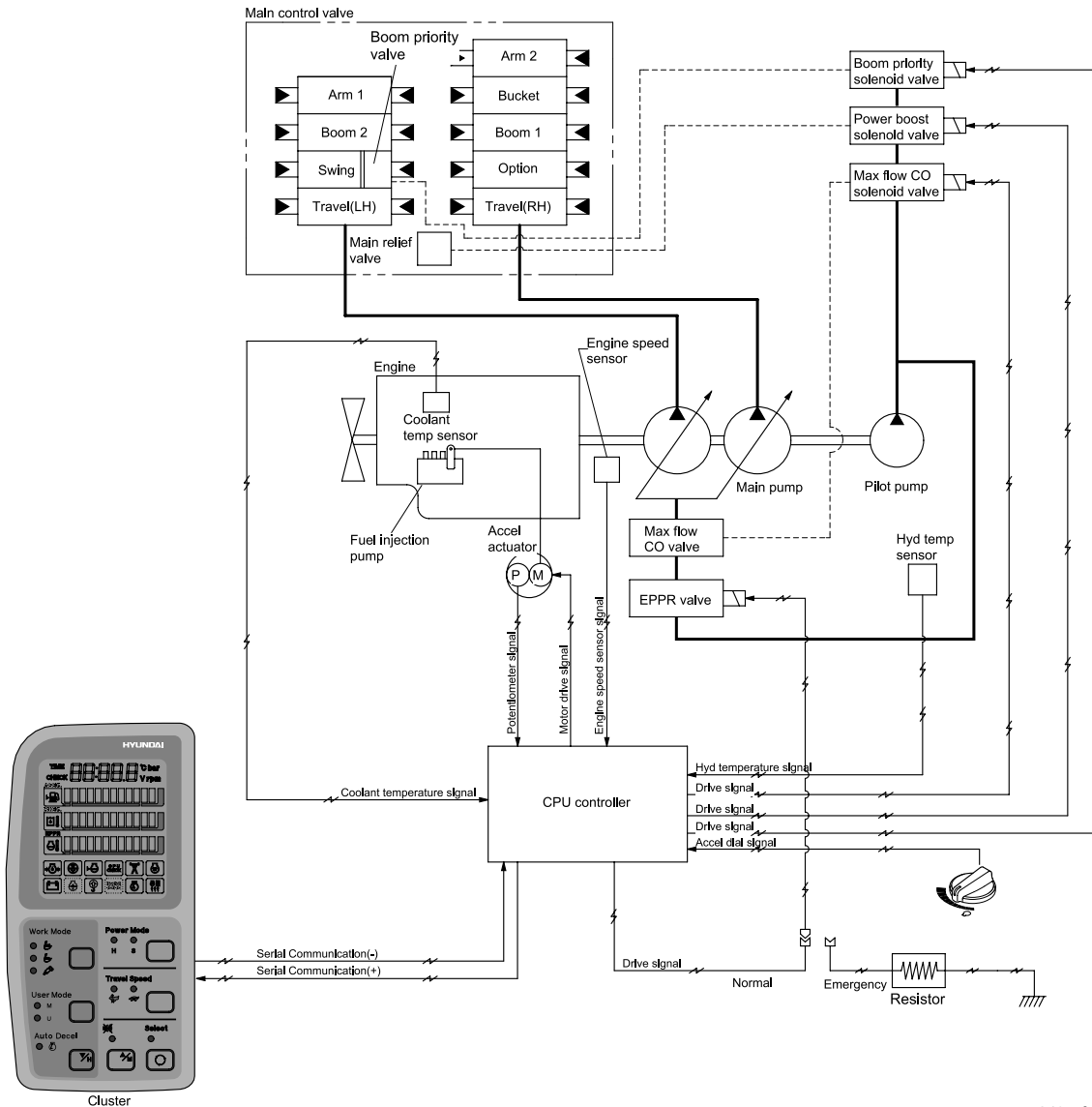

34075MS10

1) HEAVY DUTY WORK MODE

The boom priority solenoid is activated to make the boom operation speed faster.

2) GENERAL WORK MODE

When key switch is turned ON, this mode is selected and swing operation speed is faster than heavy duty work mode.

3) BREAKER OPERATION MODE

It sets the pump flow to the optimal operation of breaker by activating the max flow cut-off solenoid.

Work mode	Boom priority solenoid	Max flow cut-off solenoid
Heavy duty	ON	OFF
General	OFF	OFF
Breaker	OFF	ON

3. USER MODE SELECTION SYSTEM

An operator can change the engine and pump power and memorize it for his preference.

Mode	Operation
U	High idle rpm, auto decel rpm EPPR pressure can be modulated and memorized separately

HOW TO MODULATE THE MEMORY SET

- Each memory mode has a initial set which are mid-range of max engine speed, auto decel rpm, and EPPR valve input current. When you select M or U, cluster LCD displays.
- To change the engine high idle speed, press the USER mode switch and SELECT switch at the same time and then ACCEL blinks at 0.5 seconds interval.
 - By pressing ▲ or ▼ switch, █ will increase or decrease.
- To change DECEL rpm, press the USER mode switch and SELECT switch once more and then DECEL blinks at 0.5 seconds interval.
 - By pressing ▲ or ▼ switch, █ will increase or decrease.
- To change EPPR current, press the USER mode switch and SELECT switch one more and then EPPR blinks at 0.5 seconds interval.
 - By pressing ▲ or ▼ switch, █ will increase or decrease.

· LCD segment vs parameter setting

Segment (█)	ACCEL (rpm)	DECEL (rpm)	EPPR (mA)
1	1500	800	150
2	1550	850	200
3	1600	One touch decel low idle(900)	250
4	1650	950	300
5	1700	Decel rpm(1000)	350
6	1750	1050	400
7	1800	1100	450
8	1850	1150	500
9	1900	1200	550
10	1950	1250	600

- To memorize the final setting, press the USER mode switch and SELECT switch one more time.

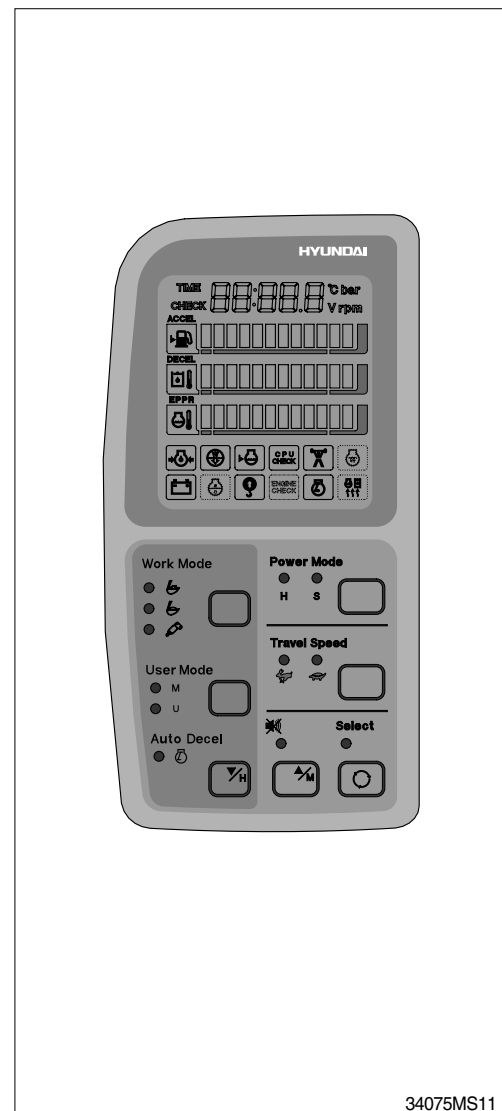
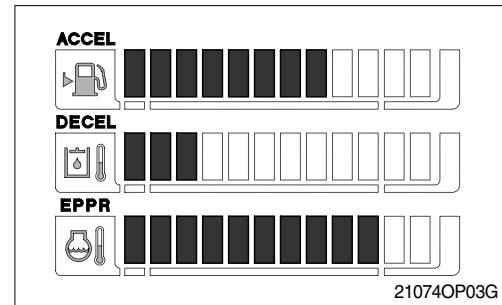

GROUP 2 MODE SELECTION SYSTEM(#0008-)

1. POWER MODE SELECTION SYSTEM

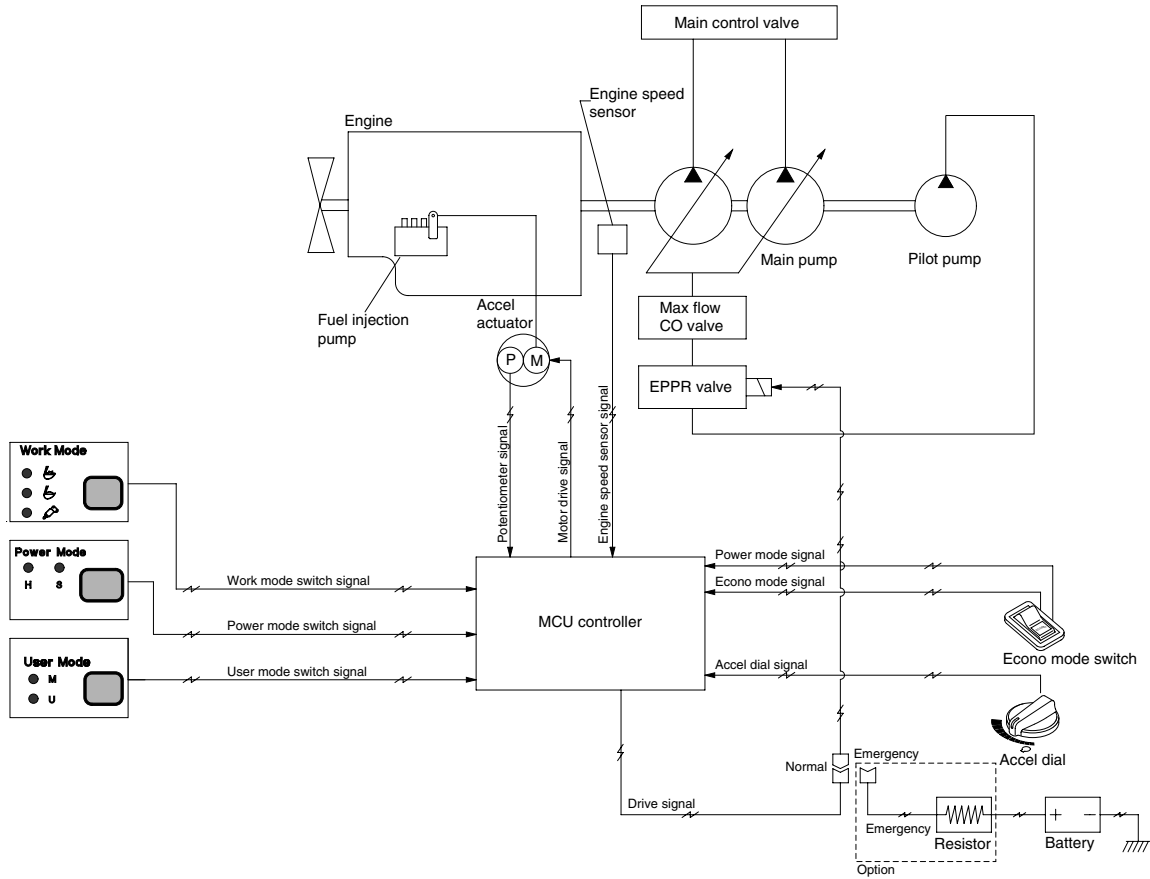

37075MS03

Mode selection system(Micro computer based electro-hydraulic pump and engine mutual control system) optimizes the engine and pump performance.

The combination of 2 power modes(H, S) and accel dial position(10 set) makes it possible to use the engine and pump power more effectively corresponding to the work conditions from a heavy and great power requesting work to a light and precise work.

Mode	Application	Power set (%)	Engine rpm		Power shift by EPPR valve			
			Unload	Load	Default		Other case	
					Current (mA)	Pressure (kgf/cm ²)	Current (mA)	Pressure (kgf/cm ²)
M	Maximum Power	95	1900±50	1750	305±30	9	250	5
H	High power	85	1800±50	1650	360±30	12	280	7
S	Standard power	70	1700±50	1550	360±30	12	280	7
AUTO DECEL	Engine deceleration	-	1000±100	-	700±30	35	700±30	35
One touch decel	Engine quick deceleration	-	900±100	-	700±30	35	700±30	35
KEY START	Key switch start position	-	900±100	-	700±30	35	700±30	35

2. WORK MODE SELECTION SYSTEM

3 work modes can be selected for the optional work speed of the machine operation.

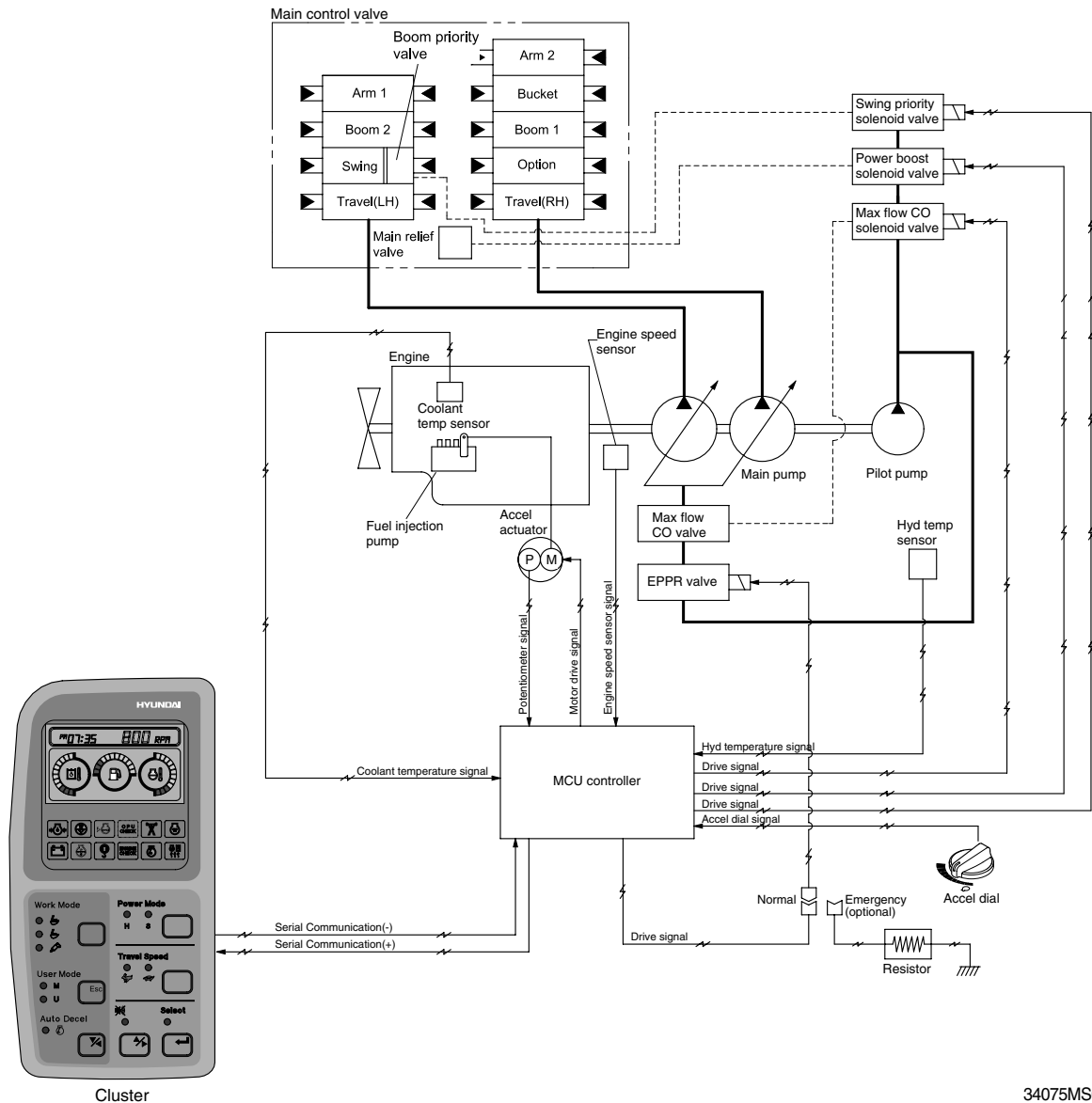

1) HEAVY DUTY WORK MODE

The boom priority solenoid is activated to make the boom operation speed faster.

2) GENERAL WORK MODE

When key switch is turned ON, this mode is selected and swing operation speed is faster than heavy duty work mode.

3) BREAKER OPERATION MODE

It sets the pump flow to the optimal operation of breaker by activating the max flow cut-off solenoid.

Work mode	Boom priority solenoid	Max flow cut-off solenoid
Heavy duty	ON	OFF
General	OFF	OFF
Breaker	OFF	ON

3. USER MODE SELECTION SYSTEM

An operator can change the engine and pump power and memorize it for his preference.

Mode	Operation
U	High idle rpm, auto decel rpm EPPR pressure can be modulated and memorized separately

HOW TO MODULATE THE MEMORY SET

- 1) Each memory mode has a initial set which are mid-range of max engine speed, auto decel rpm, and EPPR valve input current.
- 2) High idle rpm, auto decel rpm, EPPR pressure can be modulated and memorized separately in the U-mode.

※ Refer to the page 5-32 for set of user mode.

- LCD segment vs parameter setting

Segment (■)	ACCEL (rpm)	DECEL (rpm)	EPPR (mA)
1	1500	800	150
2	1550	850	200
3	1600	One touch decel low idle(900)	250
4	1650	950	300
5	1700	Decel rpm(1000)	350
6	1750	1050	400
7	1800	1100	450
8	1850	1150	500
9	1900	1200	550
10	1950	1250	600

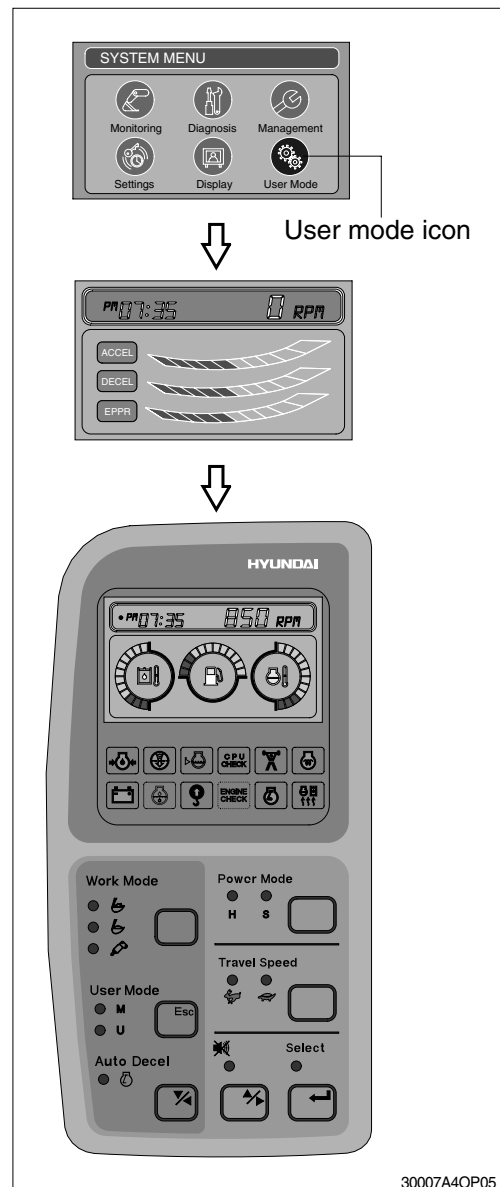
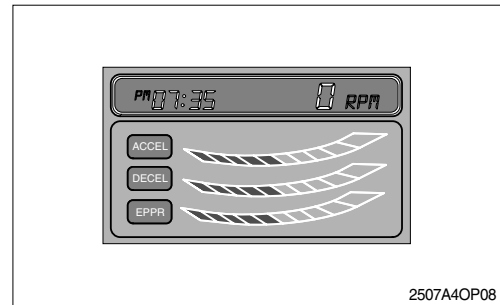

GROUP 3 AUTOMATIC DECELERATION SYSTEM

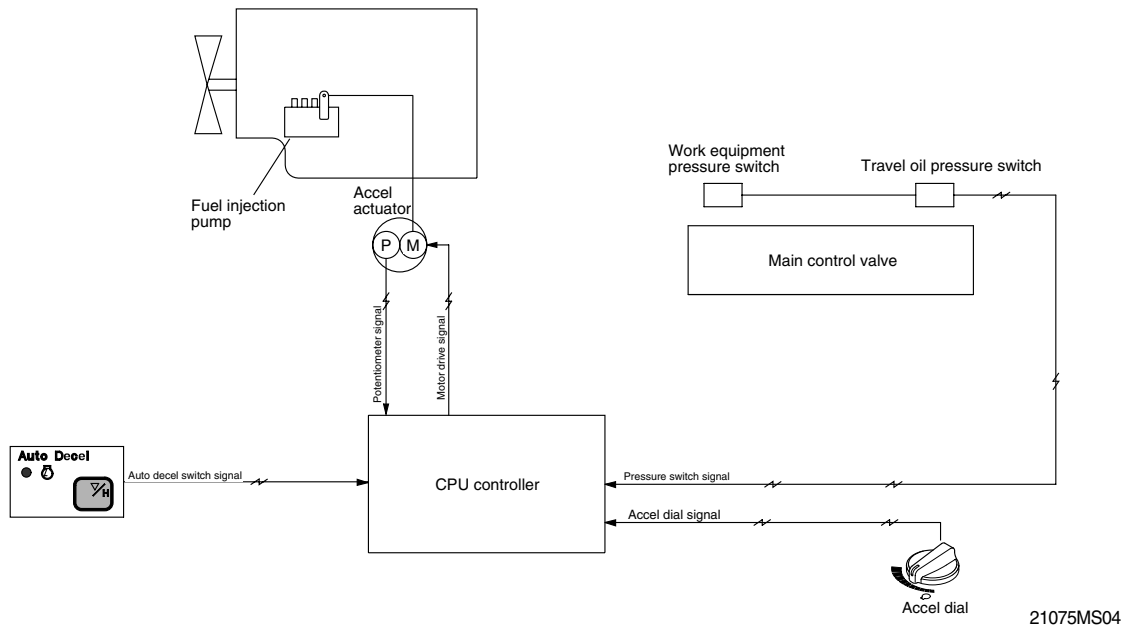

1. WHEN AUTO DECEL LAMP ON

If all the work equipment control levers including swing and travel levers are at neutral for at least 4 seconds, CPU controller drives the governor motor to reduce the engine speed to 1000rpm. As the result of reducing the engine speed, fuel consumption and noise are effectively cut down during non-operation of the control levers.

When the Auto decel lamp is turned off by pressing the switch or any control lever is operated, the reduced engine speed rises up to the speed set before deceleration in a second.

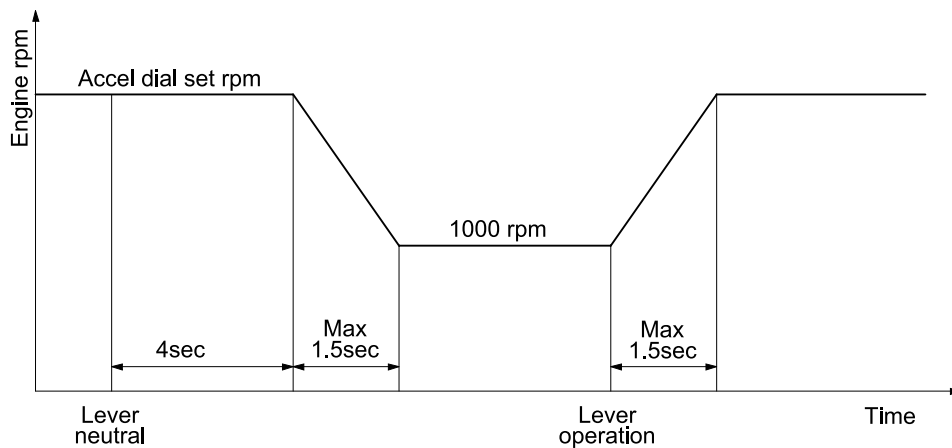

2. WHEN AUTO DECEL LAMP OFF

The engine speed can be set as desired using the engine speed switch, and even if the control levers are neutral, the engine speed is not reduced.

Note : Auto decel function can be activated when accel dial position is over 4.

GROUP 4 POWER BOOST SYSTEM

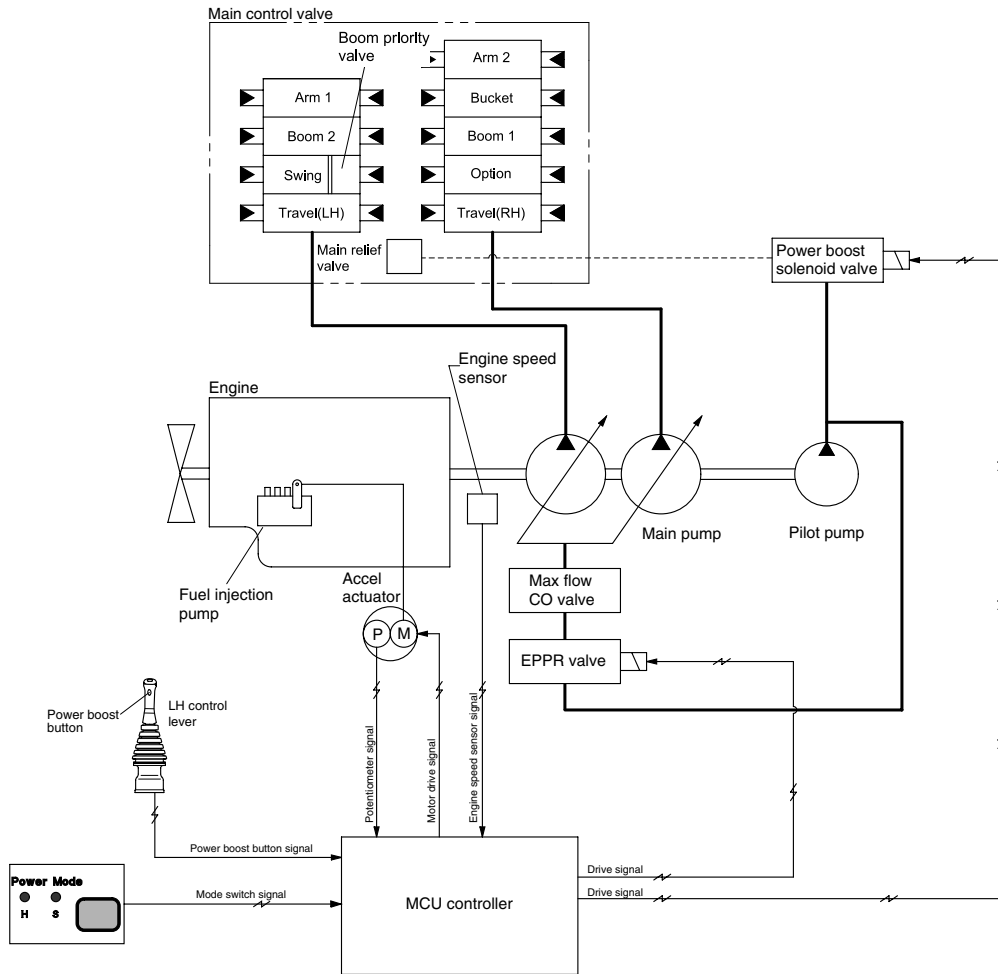

34075MS02

- When the power boost switch on the left control lever knob is pushed ON, the maximum digging power is increased by 10%.
- When the power set is at M, H or S and the power boost function is activated, the power boost solenoid valve pilot pressure raises the set pressure of the main relief valve to increase the digging power.

Description	Power boost switch	
	OFF	ON
Power set	M, H or S	M or H
Main relief valve set pressure	330kgf/cm ²	360kgf/cm ²
Time of operation	-	Even when pressed continuously, it is canceled after 8 sec.

※ Default - Power boost solenoid valve : OFF

GROUP 5 TRAVEL SPEED CONTROL SYSTEM

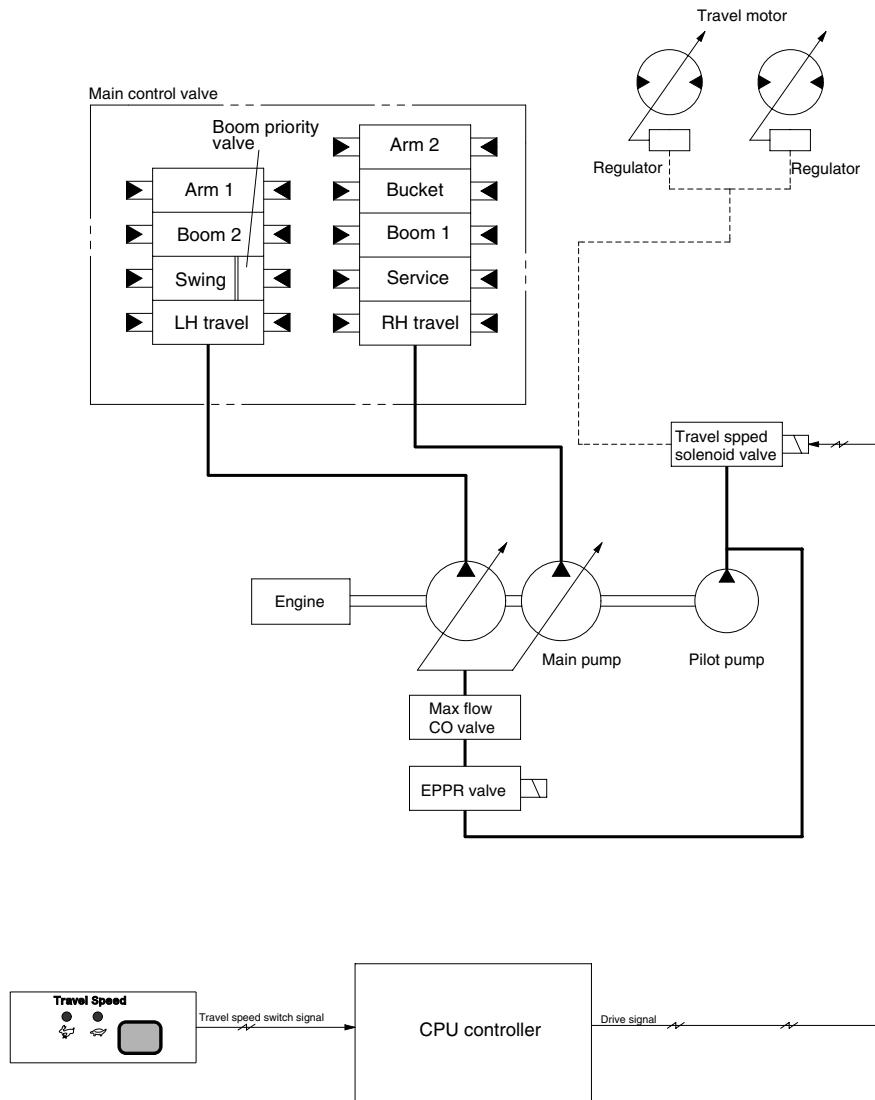

21075MS07

Travel speed can be switched manually by pressing the travel speed switch on the cluster.

Speed	Travel speed solenoid valve	Lamp on cluster	Operation
Lo	OFF	Turtle	Low speed, high driving torque in the travel motor
Hi	ON	Rabbit	High speed, low driving torque in the travel motor

※ Default : Turtle(Lo)

GROUP 6 AUTOMATIC WARMING UP FUNCTION(-#0007)

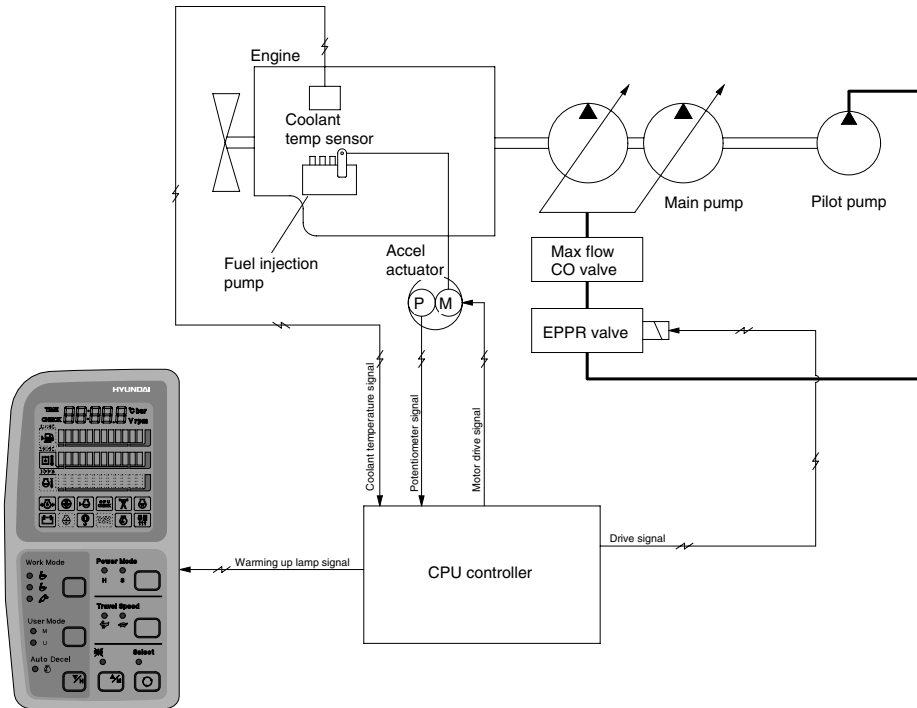

21075MS08

1. CPU controller reads engine coolant temperature through the temperature sensor, and if the coolant temperature is less than 30°C, it increases the engine speed from key start rpm to 1100rpm. At this time the mode does not change.
2. In case of the coolant temperature increases up to 30°C, the engine speed is decreased to key start speed. And if an operator changes mode set during the warming up function, the CPU controller cancels the automatic warming up function.

3. LOGIC TABLE

Description	Condition	Function
Actuated	- Coolant temperature : Less than 30°C(After engine run) - Accel dial position is under 3	- Mode : Default(S mode) - Warming up time : 10 minutes(Max) - Warming up lamp : ON
Canceled	- Coolant temperature : Above 30°C - Warming up time : Above 10 minutes - Changed mode set by operator - Increase engine speed by rotating accel dial clockwise ※ If any of the above conditions is applicable, the automatic warming up function is canceled	- Default mode - Default mode - Changed mode
Warming up lamp	- Coolant temperature : Above 30°C	- Warming up lamp : OFF

GROUP 6 AUTOMATIC WARMING UP FUNCTION(#0008-)

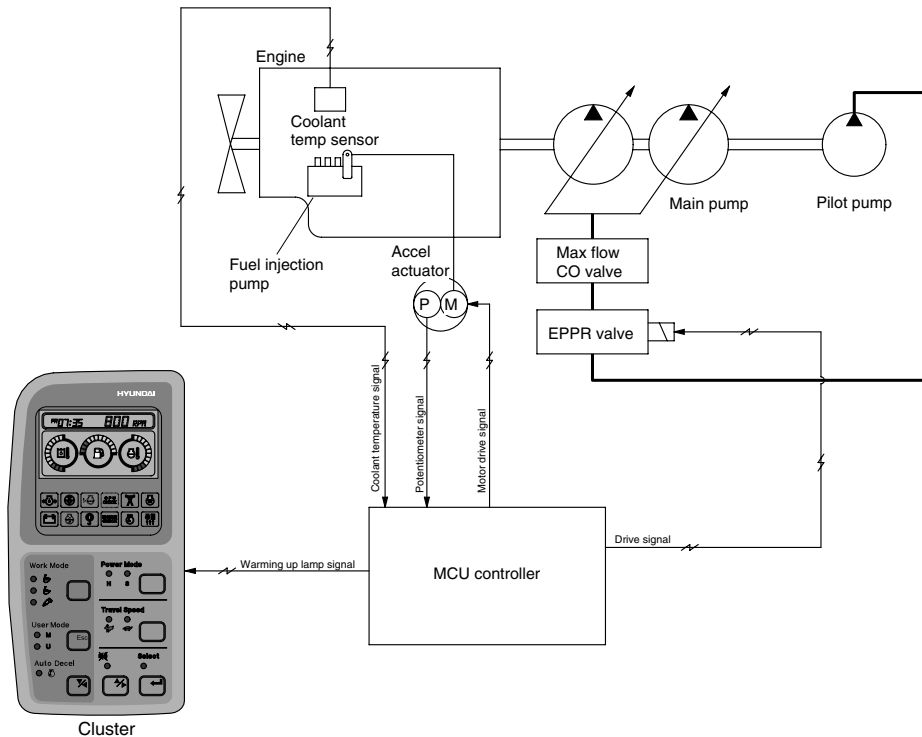

37075MS08

1. MCU controller receives engine coolant temperature through the temperature sensor, and if the coolant temperature is less than 30°C, it increases the engine speed from key start rpm to 1000rpm. At this time the mode does not change.
2. In case of the coolant temperature increases up to 30°C, the engine speed is decreased to key start speed. And if an operator changes mode set during the warming up function, the MCU controller cancels the automatic warming up function.

3. LOGIC TABLE

Description	Condition	Function
Actuated	<ul style="list-style-type: none"> - Coolant temperature : Less than 30°C (After engine run) - Accel dial position is under 3 	<ul style="list-style-type: none"> - Mode : Default(S mode) - Warming up time : 10 minutes(Max) - Warming up lamp : ON
Canceled	<ul style="list-style-type: none"> - Coolant temperature : Above 30°C - Warming up time : Above 10 minutes - Changed mode set by operator - Increase engine speed by rotating accel dial clockwise ※ If any of the above conditions is applicable, the automatic warming up function is canceled 	<ul style="list-style-type: none"> - Default mode - Default mode - Changed mode
Warming up lamp	<ul style="list-style-type: none"> - Coolant temperature : Above 30°C 	<ul style="list-style-type: none"> - Warming up lamp : OFF

GROUP 7 ENGINE OVERHEAT PREVENTION FUNCTION(-#0007)

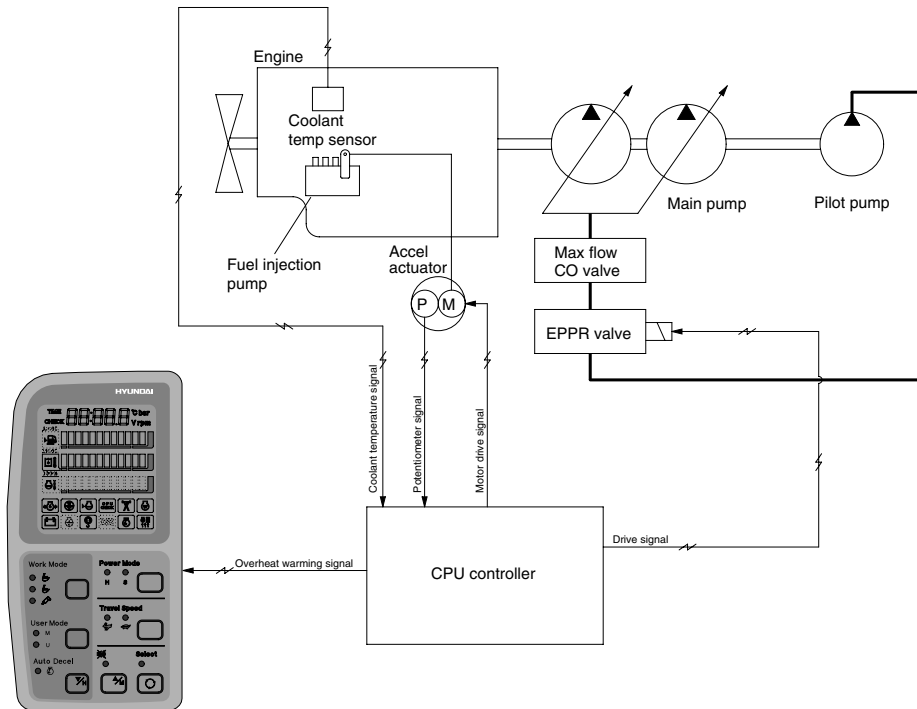

21075MS09

1. CPU controller reads engine coolant temperature through the temperature sensor and when the engine coolant boils up to 110°C, it sends overheating warning signal to the cluster and decrease the engine speed same as accel dial 7 position.
2. If the coolant temperature drops less than 100°C, the CPU controller returns the mode to the mode set before. And if mode set is changed during the function, the CPU controller cancels the function. Even if the overheat prevention function is canceled by mode change, the overheating warning lamp turns OFF only when the coolant temperature is less than 100°C.

3. LOGIC TABLE

Description	Condition	Function
Actuated	- Coolant temperature : Above 110°C - Accel dial set : Above 8	- Engine rpm drop to accel dial 7 position - Overheat warning lamp & buzzer : ON
Canceled	- Coolant temperature : Less than 100°C - Changed mode set by operator ※ If any of the above conditions is applicable, engine overheat prevention function is canceled	- Return to the mode and accel dial set before - Hold on the changed set
Overheat warning lamp	- Coolant temperature : Less than 100°C	- Overheat warning lamp : OFF

GROUP 7 ENGINE OVERHEAT PREVENTION FUNCTION(#0008-)

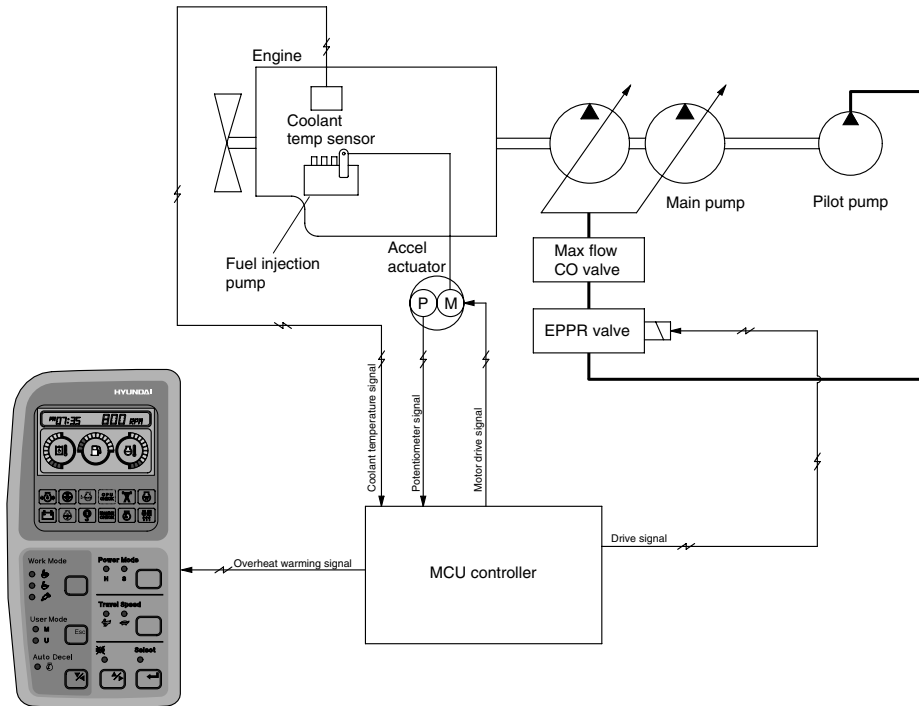

37075MS09

1. MCU controller receives engine coolant temperature through the temperature sensor and when the engine coolant boils up to 110°C, it sends overheat warning signal to the cluster and decrease the engine speed same as accel dial 7 position.
2. If the coolant temperature drops less than 100°C, the MCU controller returns the mode to the mode set before. And if mode set is changed during the function, the MCU controller cancels the function. Even if the overheat prevention function is canceled by mode change, the overheat warning lamp turns OFF only when the coolant temperature is less than 100°C.

3. LOGIC TABLE

Description	Condition	Function
Actuated	- Coolant temperature : Above 110°C - Accel dial set : Above 8	- Engine rpm drop to accel dial 7 position - Overheat warning lamp & buzzer : ON
Canceled	- Coolant temperature : Less than 100°C - Changed mode set by operator ※ If any of the above conditions is applicable, engine overheat prevention function is canceled	- Return to the mode and accel dial set before - Hold on the changed set
Overheat warning lamp	- Coolant temperature : Less than 100°C	- Overheat warning lamp : OFF

GROUP 9 SELF-DIAGNOSTIC SYSTEM(-#0007)

1. OUTLINE

When any abnormality occurs in the NEW CAPO system caused by electric parts malfunction and by open or short circuit, the CPU controller diagnoses the problem and sends the error codes to the cluster and also stores them in the memory.

The current or recorded error codes are displayed at the error display mode selected by touching **SELECT** switch 2 times while pressing **BUZZER STOP** switch.

2. CURRENT ERROR DISPLAY

Cluster displays **Co : Er** and makes buzzer sound itself to warn the communication error when communication problem caused by wire-cut or malfunction of the CPU controller occurs.

Cluster displays real time error codes received from CPU controller through communication. In case of no problem it displays **CHECK Er : 00**.

If there are more than 2 error codes, each one can be displayed by pressing ▲ and ▼ switch respectively.

Examples :

1) Communication Error

Co : Er & Buzzer sound

2) No problem

CHECK Er : 00

3) 4 Error codes(03, 06, 10, 43) display

CHECK Er : 03

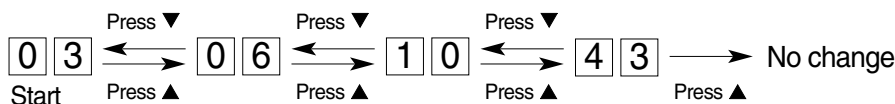

3. RECORDED ERROR DISPLAY



The recorded error can be displayed only when the key switch is at ON position.

Examples : 5 Recorded error codes(03, 06, 10, 20, 32) display

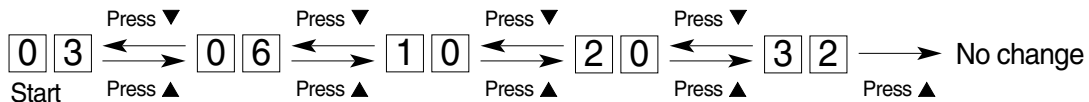
TIME Er : 03



4. DELETE ALL RECORDED ERROR CODES

Select recorded error(**TIME Er**) display and press engine  and select switch  at the same time for 2 seconds or more. Cluster display changes to **TIME Er : 00**, which shows that CPU controller deleted all the recorded error codes in the memory.

5. ERROR CODES TABLE

Fault code No.	Description
1	Short circuit in governor motor system
2	Potentiometer circuit is shorted to Vcc(5V) or battery +
3	Short circuit in pump EPPR valve system
4	Short circuit in boom down EPPR valve system
5	Short circuit in travel speed solenoid system
6	Short circuit in power boost solenoid system
7	Short circuit in max flow solenoid system
10	Short circuit in hour-meter system
11	Accel dial circuit is shorted to Vcc(5V) or battery +
12	P1 pressure sensor circuit is shorted to power supply(24V) line
13	P2 pressure sensor circuit is shorted to power supply(24V) line
14	P3 pressure sensor circuit is shorted to power supply(24V) line
15	Boom down pressure circuit is shorted to power supply(24V) line
16	Governor motor circuit is open or shorted to ground
17	Potentiometer circuit is open or shorted to ground
18	Pump EPPR valve circuit is open or shorted to ground
19	Boom down EPPR valve circuit is open or shorted to ground
20	Travel speed solenoid circuit is open or shorted to ground
21	Power boost solenoid circuit is open or shorted to ground
22	Max flow solenoid circuit is open or shorted to ground
25	Hour-meter circuit is open or shorted to ground
26	Accel dial circuit is open or shorted to ground
27	P1 pressure sensor circuit is open or shorted to ground
28	P2 pressure sensor circuit is open or shorted to ground
29	P3 pressure sensor circuit is open or shorted to ground
30	Boom down pressure sensor circuit is open or shorted to ground
31	Engine preheater circuit is open or shorted to ground
32	Travel alarm buzzer circuit is open or shorted to ground
33	Alternator circuit is open or shorted to ground
34	Controller input voltage is below 18V
35	Controller input voltage is over 38V
36	Communication error with cluster
37	Engine speed sensor circuit is open or shorted to ground
38	Anti-restart relay circuit is open or shorted to ground
39	Accel actuator does not stop at a target position
40	There is more than 500rpm difference between target speed and actual speed

Fault code No.	Description
41	Hydraulic oil temperature sensor circuit is shorted to ground
42	Fuel level sensor circuit is shorted to ground
43	Coolant temperature sensor circuit is shorted to ground
44	Boom up pressure sensor circuit is shorted to power supply(24V) line
45	Hydraulic oil temperature sensor circuit is open or shorted to battery +
46	Fuel level sensor circuit is open or shorted to battery +
47	Coolant temperature sensor circuit is open or shorted to battery +
48	Boom up pressure sensor circuit is open or shorted to ground
49	Engine preheater circuit is shorted to battery +
51	Boom priority solenoid circuit is open or shorted to ground
56	Travel alarm buzzer circuit is shorted to battery +
58	Boom priority solenoid circuit is shorted to battery +

GROUP 9 SELF-DIAGNOSTIC SYSTEM(#0008-)

1. OUTLINE

When any abnormality occurs in the NEW CAPO system caused by electric parts malfunction and by open or short circuit, the MCU controller diagnoses the problem and sends the error codes to the cluster and also stores them in the memory.

The current or recorded error codes are displayed at the error display mode selected by touching **SELECT** switch 2 times while pressing **BUZZER STOP** switch.

2. CURRENT ERROR DISPLAY

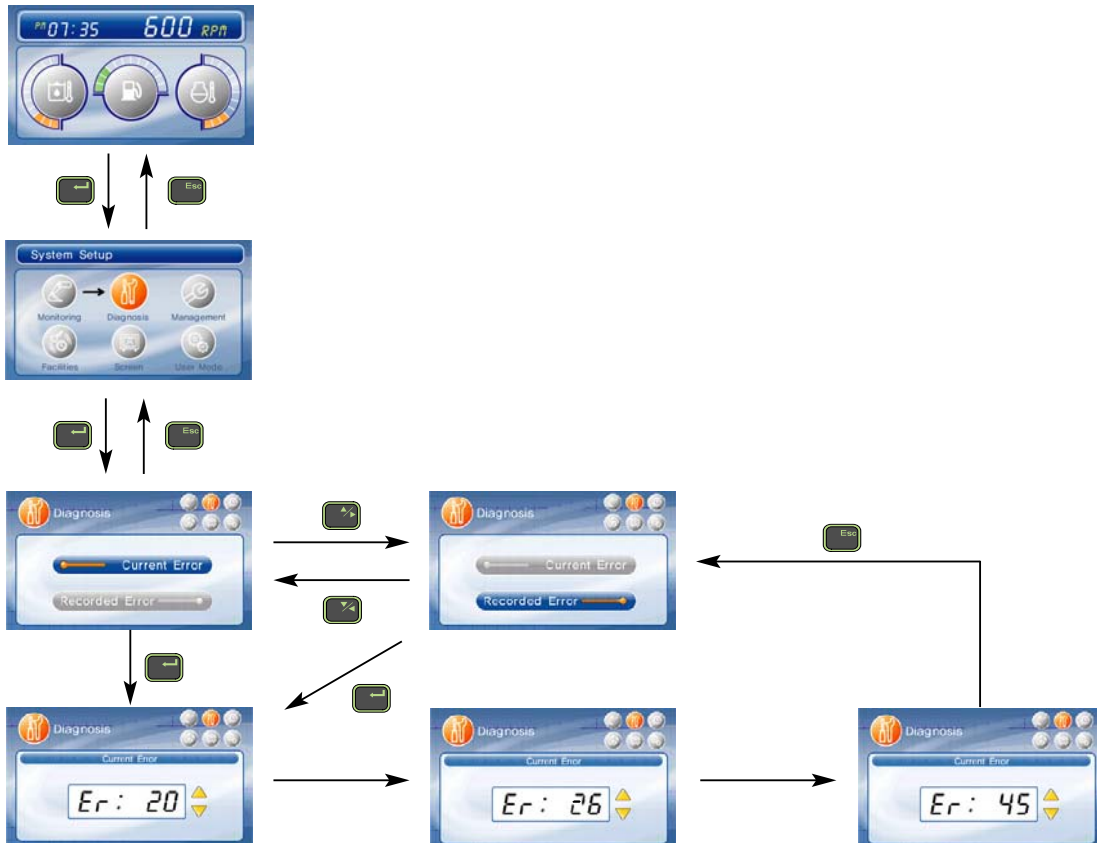

3. ERROR CODES TABLE

Error code No.	Description
1	Short circuit in accel actuator system
2	Potentiometer circuit is shorted to Vcc(5V) or battery +
3	Short circuit in pump EPPR valve system
4	Short circuit in boom down EPPR valve system
5	Short circuit in travel speed solenoid system
6	Short circuit in power boost solenoid system
7	Short circuit in max flow solenoid system
10	Short circuit in hour-meter system
11	Accel dial circuit is shorted to Vcc(5V) or battery +
12	P1 pressure sensor circuit is shorted to power supply(24V) line
13	P2 pressure sensor circuit is shorted to power supply(24V) line
14	P3 pressure sensor circuit is shorted to power supply(24V) line
15	Boom down pressure circuit is shorted to power supply(24V) line
16	Accel actuator circuit is open or shorted to ground
17	Potentiometer circuit is open or shorted to ground
18	Pump EPPR valve circuit is open or shorted to ground
19	Boom down EPPR valve circuit is open or shorted to ground
20	Travel speed solenoid circuit is open or shorted to ground
21	Power boost solenoid circuit is open or shorted to ground
22	Max flow solenoid circuit is open or shorted to ground
25	Hour-meter circuit is open or shorted to ground
26	Accel dial circuit is open or shorted to ground
27	P1 pressure sensor circuit is open or shorted to ground
28	P2 pressure sensor circuit is open or shorted to ground
29	P3 pressure sensor circuit is open or shorted to ground
30	Boom down pressure sensor circuit is open or shorted to ground
31	Engine preheater circuit is open or shorted to ground
32	Travel alarm buzzer circuit is open or shorted to ground
33	Alternator circuit is open or shorted to ground
34	Controller input voltage is below 18V

Error code No.	Description
35	Controller input voltage is over 38V
36	Communication error with cluster
37	Engine speed sensor circuit is open or shorted to ground
38	Anti-restart relay circuit is open or shorted to ground
39	Accel actuator does not stop at a target position
40	There is more than 500rpm difference between target speed and actual speed
41	Hydraulic oil temperature sensor circuit is shorted to ground
42	Fuel level sensor circuit is shorted to ground
43	Coolant temperature sensor circuit is shorted to ground
44	Boom up pressure sensor circuit is shorted to power supply(24V) line
45	Hydraulic oil temperature sensor circuit is open or shorted to battery +
46	Fuel level sensor circuit is open or shorted to battery +
47	Coolant temperature sensor circuit is open or shorted to battery +
48	Boom up pressure sensor circuit is open or shorted to ground
49	Engine preheater circuit is shorted to battery +
51	Boom priority solenoid circuit is open or shorted to ground
56	Travel alarm buzzer circuit is shorted to battery +
58	Boom priority solenoid circuit is shorted to battery +

GROUP 10 ENGINE CONTROL SYSTEM

1. MCU MOUNTING

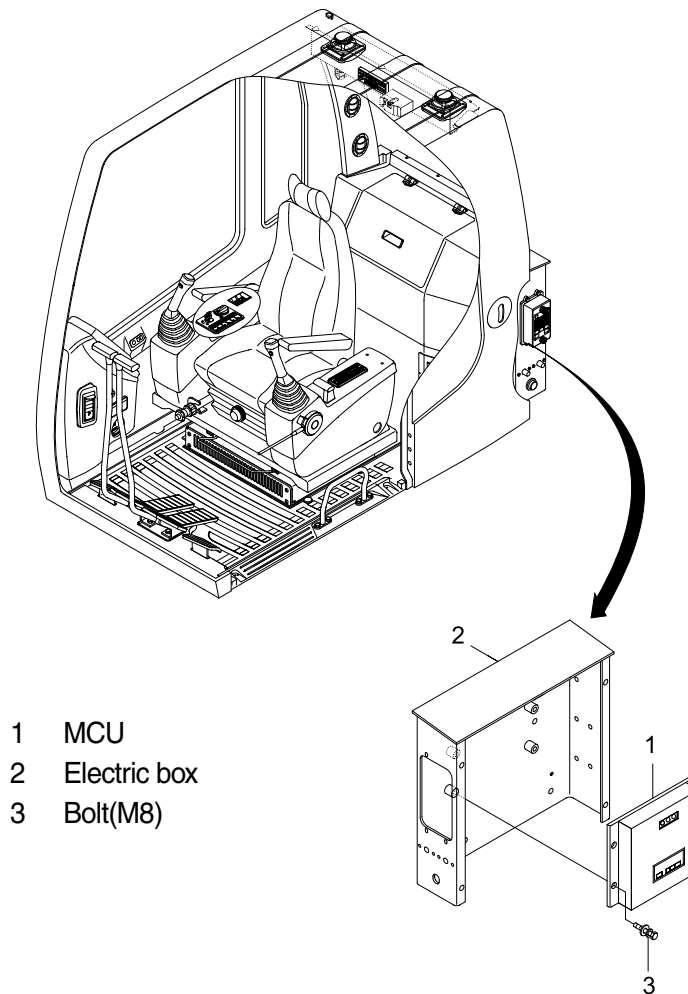

- 1 MCU
- 2 Electric box
- 3 Bolt(M8)

21075MS11

2. MCU ASSEMBLY

- 1) To match the pump absorption torque with the engine torque, MCU varies EPPR valve output pressure, which control pump discharge amount whenever feedbacked engine speed drops under the reference rpm of each mode set.
- 2) Three LED lamps on the MCU display as below.

LED lamp	Trouble	Service
G is turned ON	Normal	-
G and R are turned ON	Trouble on MCU	· Change the MCU
G and Y are turned ON	Trouble on serial communication line	· Check if serial communication lines between controller and cluster are disconnected
Three LED are turned OFF	Trouble on MCU power	· Check if the input power wire (24 V, GND) of controller is disconnected · Check the fuse

G : green, R : red, Y : yellow

3. EXCHANGE METHOD OF THE ROM

- 1) Disassemble the ash tray(2).
- 2) Disassemble the wiper motor cover(3).
- 3) Disassemble the cluster(1).

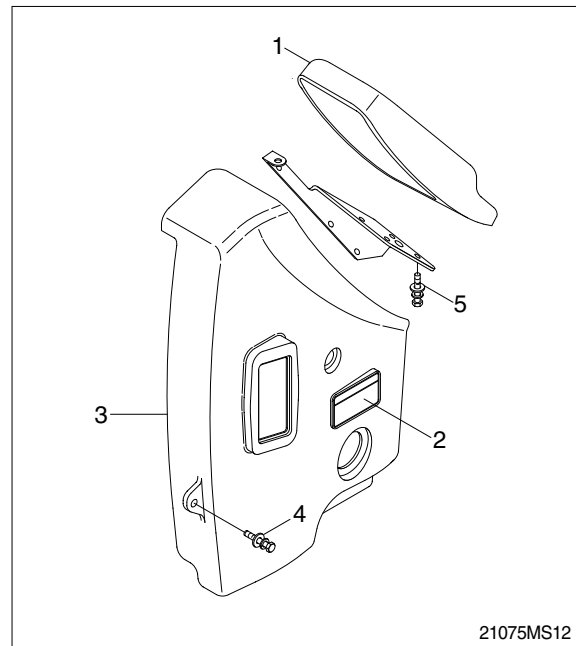

- 4) Loosen the screws(6EA) located back of the cluster.
- 5) Then you can open the upper case of the cluster easily.

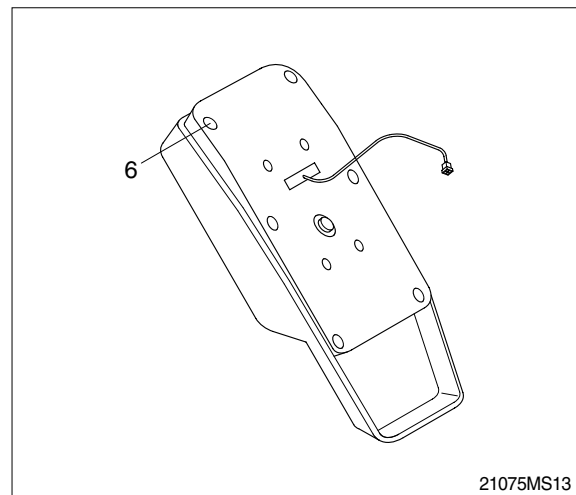

- 6) Install the new ROM.(Be careful of direction and assmelbe the cluster in the reverse order to removal).

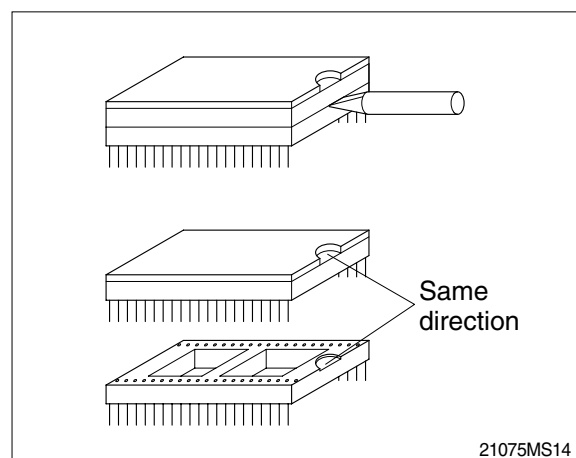

4. ENGINE ACCEL ACTUATOR

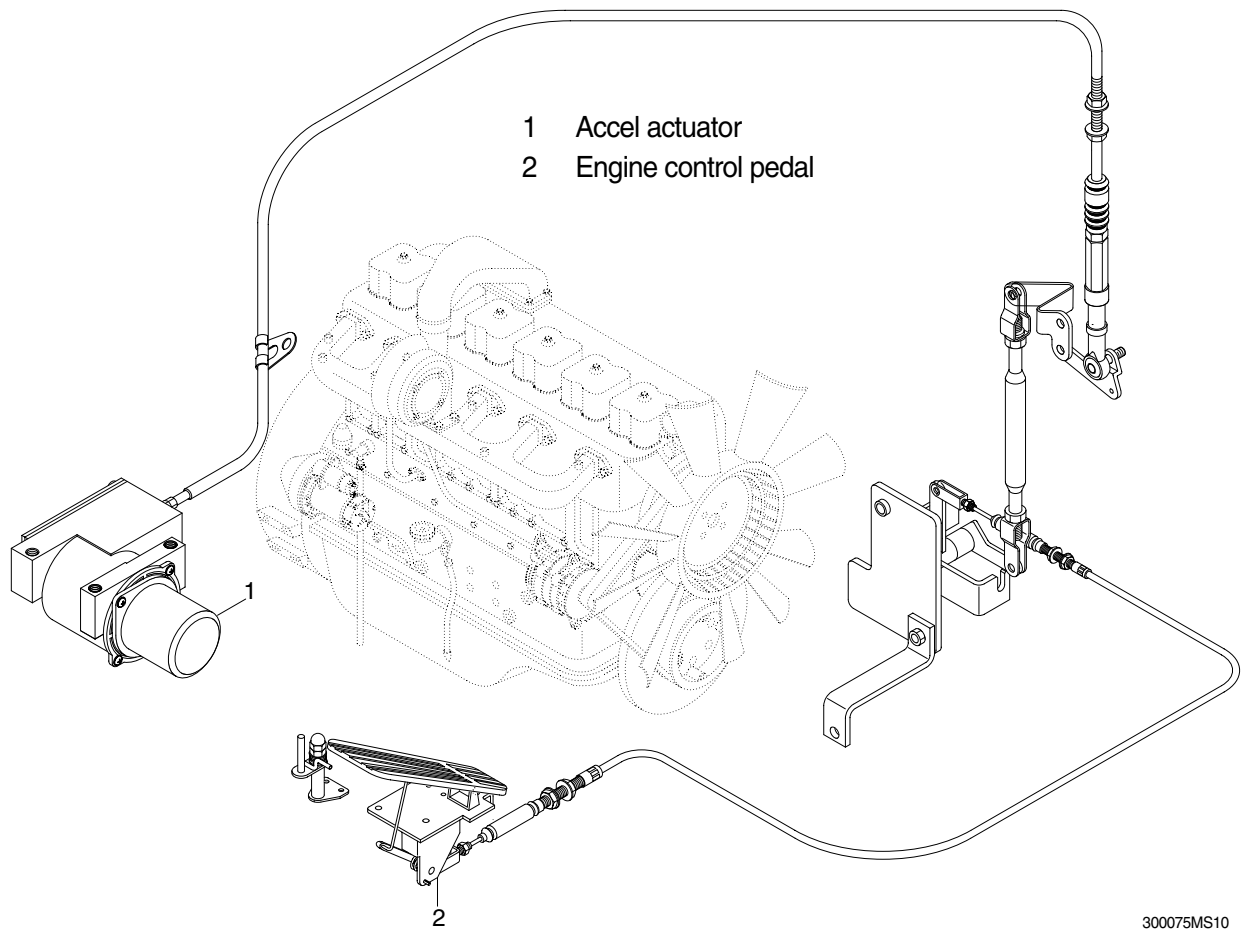

1) ENGINE THROTTLE LEVER

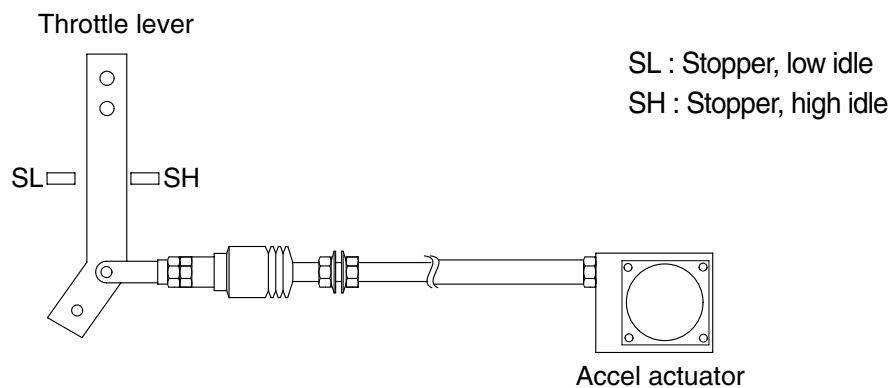

5-18(2)

2) EMERGENCY CABLE (Push-pull cable)

It controls engine speed by connecting onto the lever of the injection pump when the malfunction of the MCU controller or the accel actuator happen.

3) ACCEL ACTUATOR

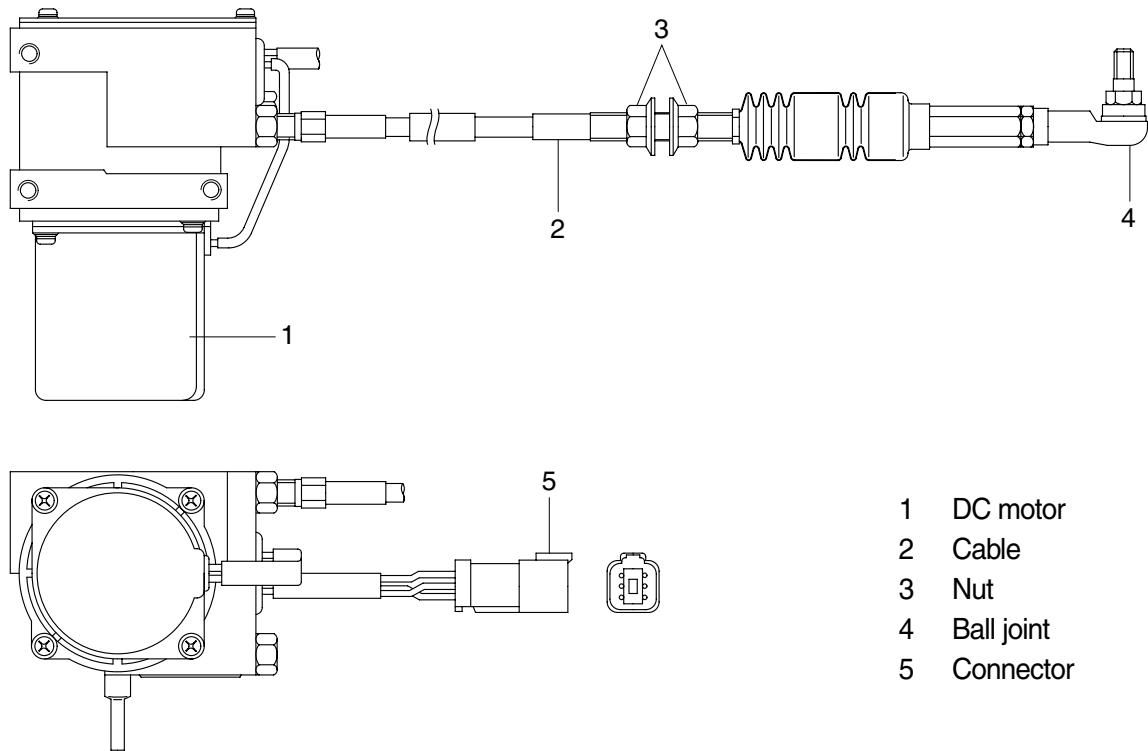

- 1 DC motor
- 2 Cable
- 3 Nut
- 4 Ball joint
- 5 Connector

5-19(1) 210-7

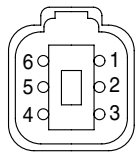
Connector		
Type	6P, female	
Line color & description	1	White(Potentiometer 5V)
	2	Blue(Potentiometer SIG)
	3	Black(Potentiometer GND)
	4	-
	5	Green(Motor+)
	6	Yellow(Motor -)
Inspection	Check resistance Spec : 1~2 Ω (Between No.5-6) 0.8~1.2kΩ (Between No.1-3)	

4) ACCEL ACTUATOR CABLE SETTING PROCEDURE

(1) Key OFF

- ① Connect the ball joint of cable to engine throttle lever.
- ② Pull the cable to high stopper and put nut **A** edge to yoke of the bracket.
 - ※ Make throttle lever not contact to the edge of high stopper.
- ③ Turn nut **A** to clockwise until touching to the edge of high stopper.
- ④ Make 1 turn more to clockwise in condition of the nut **A** contact to the edge of high stopper.

(2) Key START

- ⑤ Confirm if the engine speed on cluster is same as each mode specification.
- ⑥ If the engine speed displayed on cluster is higher than each mode specification, then turn the nut **A** to counter clockwise and make the engine speed same to each mode specification.
- ⑦ If the engine speed displayed on cluster is lower than each mode specification, then turn the nut **A** to clockwise and make the engine speed same to each mode specification.
- ⑧ Turn nut **B** to clockwise and fix the cable to bracket.

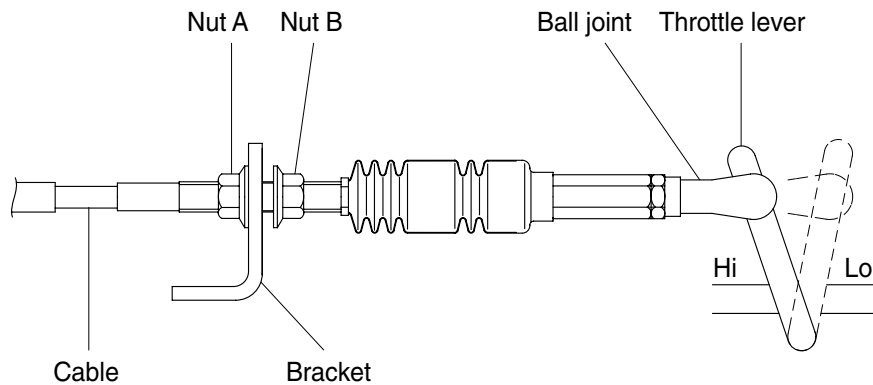

130W5MS05

Mode	RPM
H	1800±50
S	1700±50
Auto decel	1000±100
Key start	900±100

5. ENGINE SPEED SENSOR

1) DETECT ACTUAL ENGINE RPM AND SEND SIGNAL TO TACHOMETER

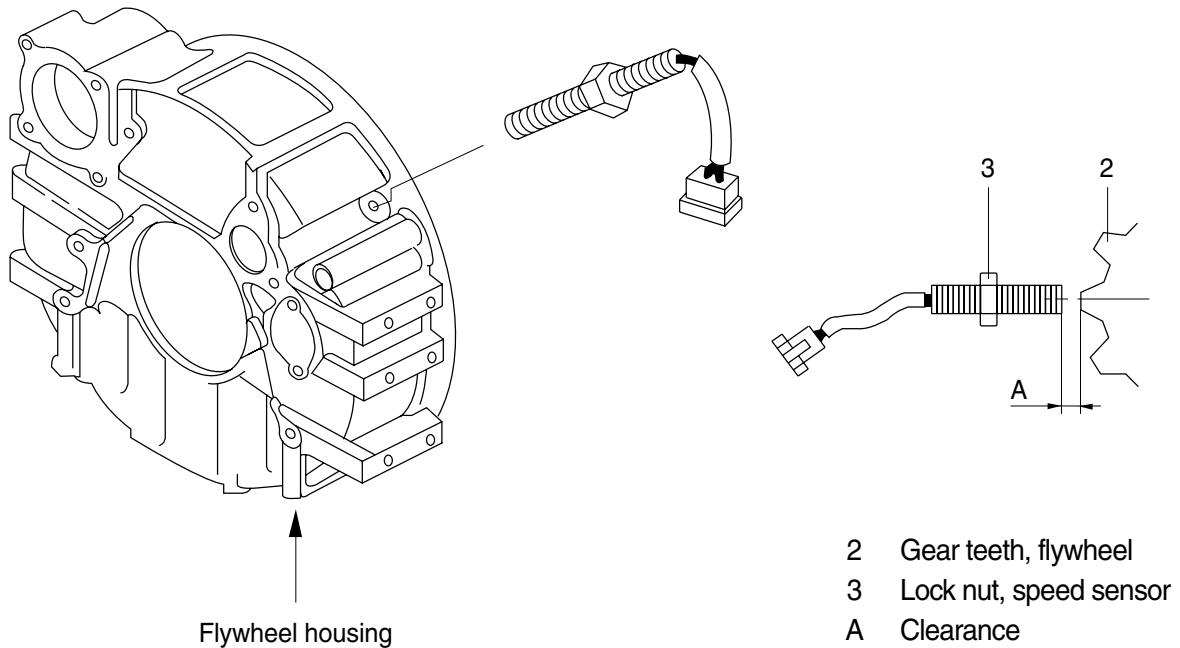

5-20 (210-7)

2) INSTALLATION

- (1) Clean contacting point of sensor.
- (2) Loosen lock nut.
- (3) Screw speed sensor into flywheel housing.
- (4) Turn it back 135° when it contacts with gear teeth.
- (5) Tight lock nut and connect wiring.

3) INSPECTION

- (1) Check resistance
 - SPEC : 300 Ω
- (2) Check voltage while engine run.
 - SPEC : 2~28Vac, dependent on the engine speed(rpm)

GROUP 11 EPPR VALVE(-#0007)

1. COMPOSITION OF EPPR VALVE

EPPR(Electro Proportional Pressure Reducing) valve consists of electro magnet and spool valve installed at main hydraulic pump.

1) ELECTRO MAGNET VALVE

Receive electric current from CPU controller and move the spool proportionally according to the specific amount of electric current value.

2) SPOOL VALVE

Is the two way direction control valve for pilot pressure to reduce hydraulic pump flow.

When the electro magnet valve is activated, pilot pressure enters into flow regulator of hydraulic pump. So, pump flow decreases to prevent engine stall.

3) PRESSURE AND ELECTRIC CURRENT VALUE FOR EACH MODE

Mode		Pressure		Electric current (mA)	Engine rpm (At accel dial 10)
		kgf/cm ²	psi		
Standard (Ver : 1.x)	M	9 ± 3	128 ± 40	305 ± 30	1900 ± 50
	H	12 ± 3	170 ± 40	360 ± 30	1800 ± 50
	S	12 ± 3	170 ± 40	360 ± 30	1700 ± 50
Option (Ver : 2.x)	M	5 ± 3	71 ± 40	250 ± 30	1900 ± 50
	H	7 ± 3	100 ± 40	280 ± 30	1800 ± 50
	S	7 ± 3	100 ± 40	280 ± 30	1700 ± 50
★		17 ± 3	245 ± 40	440 ± 30	-



★ Manually operated condition when prolix resistor is connected in emergency operation.

2. HOW TO SWITCH THE VERSION(1.x ↔ 2.x) ON THE CLUSTER

You can switch the EPPR valve pressure set by selecting the version(1.x ↔ 2.x).

Step 1. Turn the key switch **ON**.

Step 2. Press the **SELECT** switch 3 times.

Step 3. While 7 segment on the cluster shows the version of the CPU controller program, for example **32C1.0** press the buzzer stop switch() + travel speed control switch() at the same time for 2 seconds.

The display changes to **32C2.0**, and it indicates that version 2.0(Option) is selected.

※ If you want to get back to ver:1.x, go to step 1~3.

2. OPERATING PRINCIPLE

1) STRUCTURE

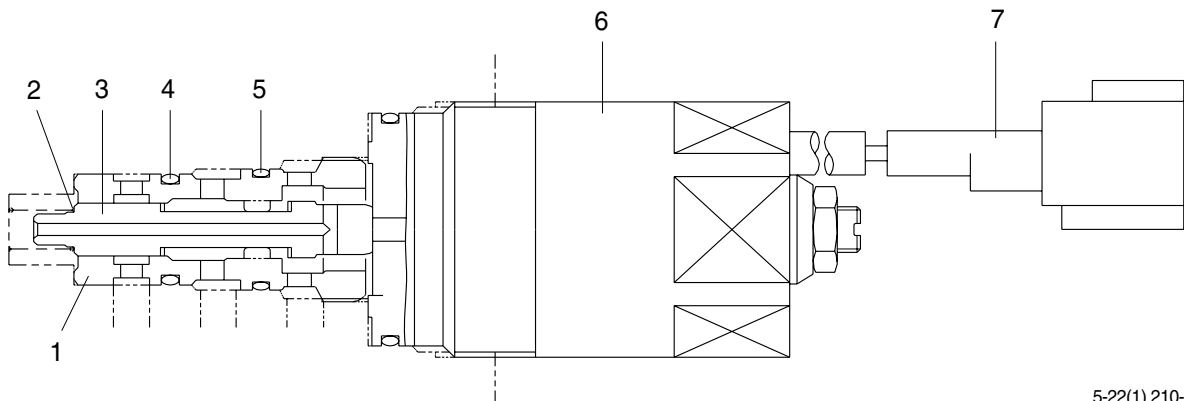

5-22(1) 210-7

- | | | |
|----------|----------|------------------|
| 1 Sleeve | 4 O-ring | 6 Solenoid valve |
| 2 Spring | 5 O-ring | 7 Connector |
| 3 Spool | | |

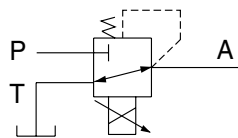

5-22A (210-7)

- P Pilot oil supply line(Pilot pressure)
 T Return to tank
 A Secondary pressure to flow regulator at hydraulic pump

2) AT H MODE

Pressure line is blocked and A oil returns to tank.

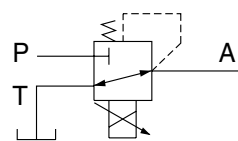

5-22B (210-7)

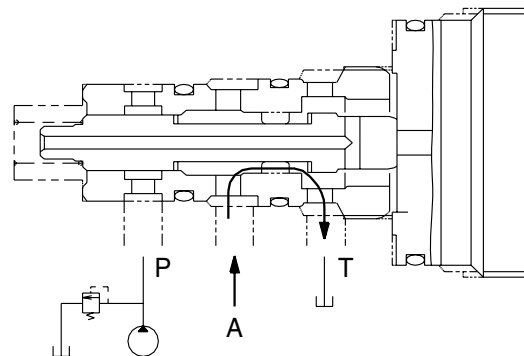

3) AT S MODE

Secondary pressure enters into A.

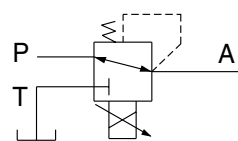

5-22C (210-7)

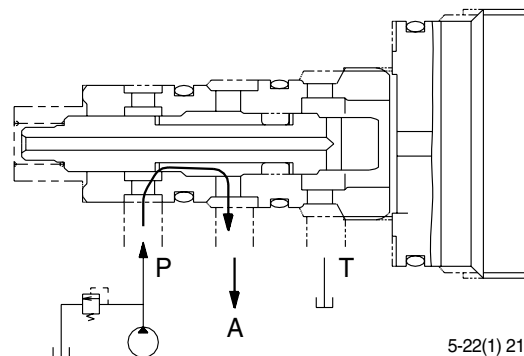

5-22(1) 210-7

3. EPPR VALVE CHECK PROCEDURE

1) CHECK ELECTRIC VALUE AT EPPR VALVE

- (1) Start engine.
- (2) Set S-mode and cancel auto decel mode.
- (3) Position the accel dial at 10.
- (4) If tachometer show approx 1700 ± 50 rpm, disconnect one wire harness from EPPR valve.
- (5) Install multimeter as figure.
- (6) Check electric current at bucket circuit relief position.

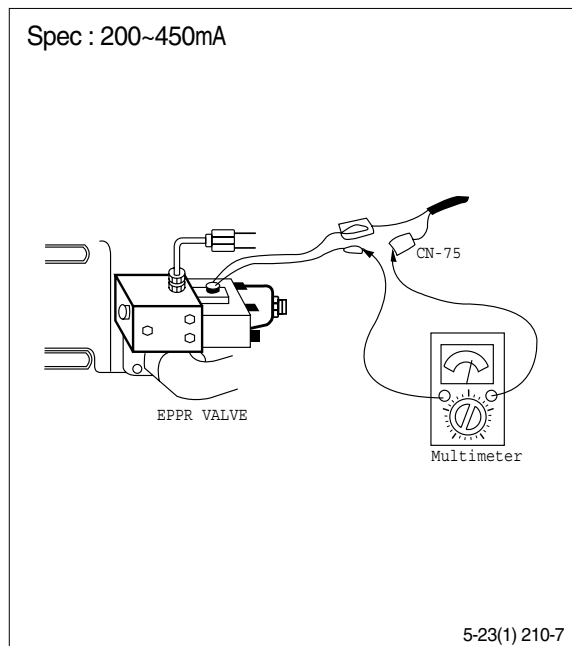

2) CHECK PRESSURE AT EPPR VALVE

- (1) Remove plug and connect pressure gauge as figure.
 - Gauge capacity : 0 to 40-50kgf/cm²
(0 to 580-725psi)
- (2) Start engine.
- (3) Set S-mode and cancel auto decel mode.
- (4) Position the accel dial at 10.
- (5) If tachometer show approx 1700 ± 50 rpm, check pressure at relief position of bucket circuit by operating bucket control lever.
- (6) If pressure is not correct, adjust it.
- (7) After adjust, test the machine.

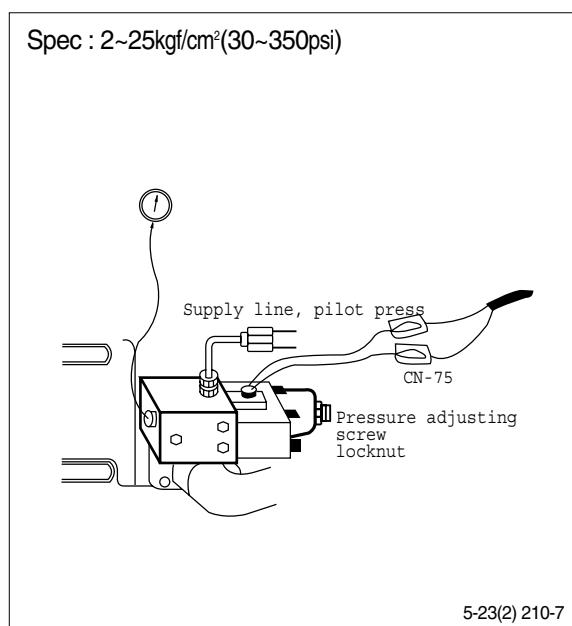

GROUP 11 EPPR VALVE(#0008-)

1. COMPOSITION OF EPPR VALVE

EPPR(Electro Proportional Pressure Reducing) valve consists of electro magnet and spool valve installed at main hydraulic pump.

1) ELECTRO MAGNET VALVE

Receive electric current from MCU controller and move the spool proportionally according to the specific amount of electric current value.

2) SPOOL VALVE

Is the two way direction control valve for pilot pressure to reduce hydraulic pump flow.

When the electro magnet valve is activated, pilot pressure enters into flow regulator of hydraulic pump. So, pump flow decreases to prevent engine stall.

3) PRESSURE AND ELECTRIC CURRENT VALUE FOR EACH MODE

Mode		Pressure		Electric current (mA)	Engine rpm (At accel dial 10)
		kgf/cm ²	psi		
Standard (Ver : 1.x)	M	9 ± 3	128 ± 40	305 ± 30	1900 ± 50
	H	12 ± 3	170 ± 40	360 ± 30	1800 ± 50
	S	12 ± 3	170 ± 40	360 ± 30	1700 ± 50
Option (Ver : 2.x)	M	5 ± 3	71 ± 40	250 ± 30	1900 ± 50
	H	7 ± 3	100 ± 40	280 ± 30	1800 ± 50
	S	7 ± 3	100 ± 40	280 ± 30	1700 ± 50
★		17 ± 3	245 ± 40	440 ± 30	-

★ Manually operated condition when prolix switch resistor is selected emergency position.

2. HOW TO SWITCH THE VERSION(3.1↔4.1) ON THE CLUSTER

You can switch the EPPR valve pressure set by selecting the version(3.1 ↔4.1).

- Dual mode
 - Changing the MCU mode



2. OPERATING PRINCIPLE

1) STRUCTURE

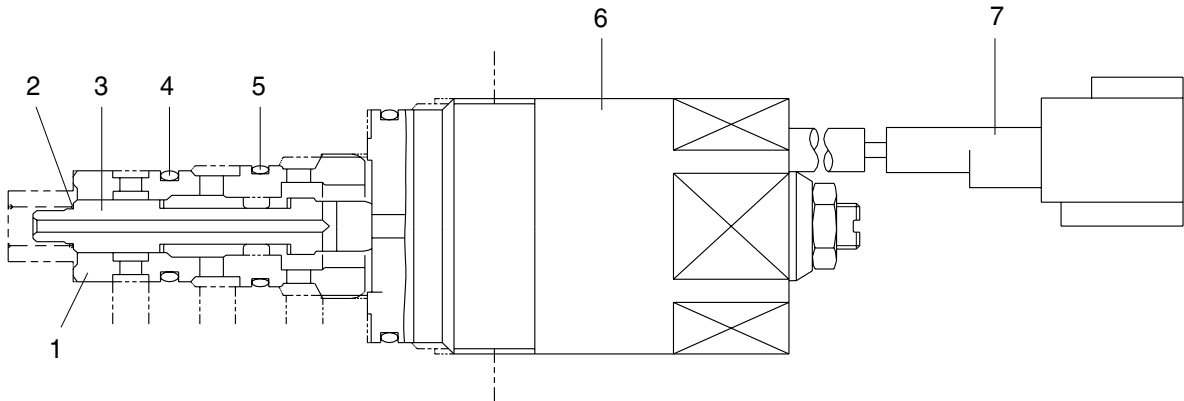

5-22(1) 360-7

- 1 Sleeve
- 2 Spring
- 3 Spool

- 4 O-ring
- 5 O-ring

- 6 Solenoid valve
- 7 Connector

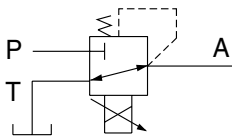

- P Pilot oil supply line(Pilot pressure)
- T Return to tank
- A Secondary pressure to flow regulator at hydraulic pump

2) AT H MODE

Pressure line is blocked and A oil returns to tank.

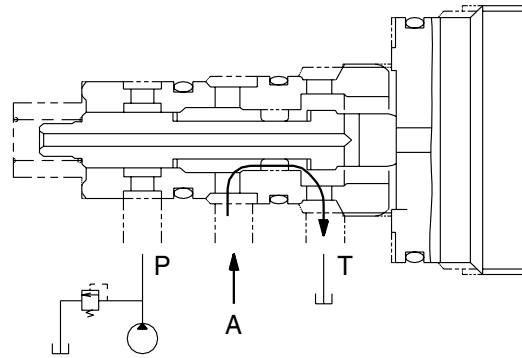
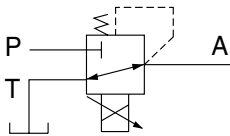

3) AT S MODE

Secondary pressure enters into A.

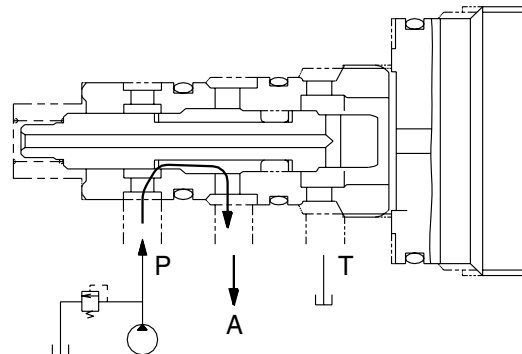
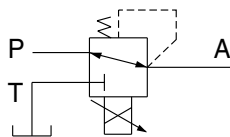

5-22(2) 360-7

3. EPPR VALVE CHECK PROCEDURE

1) CHECK ELECTRIC VALUE AT EPPR VALVE

- (1) Start engine.
- (2) Set S-mode and cancel auto decel mode.
- (3) Position the accel dial at 10.
- (4) If tachometer show approx 1700 ± 50 rpm, disconnect one wire harness from EPPR valve.
- (5) Install multimeter as figure.
- (6) Check electric current at bucket circuit relief position.

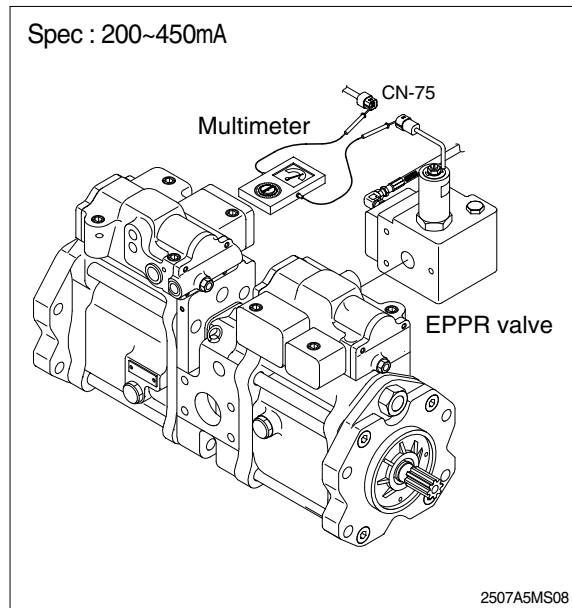

2) CHECK PRESSURE AT EPPR VALVE

- (1) Remove plug and connect pressure gauge as figure.
 - Gauge capacity : 0 to 40-50kgf/cm²
(0 to 580-725psi)
- (2) Start engine.
- (3) Set S-mode and cancel auto decel mode.
- (4) Position the accel dial at 10.
- (5) If tachometer show approx 1700 ± 50 rpm, check pressure at relief position of bucket circuit by operating bucket control lever.
- (6) If pressure is not correct, adjust it.
- (7) After adjust, test the machine.

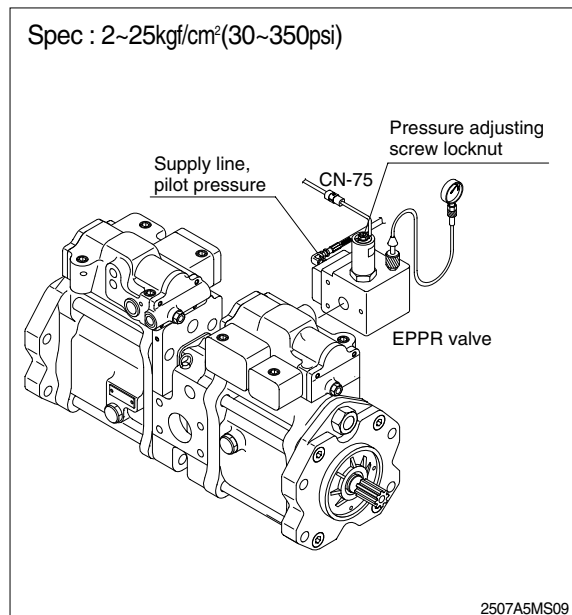

GROUP 12 PROLIX SYSTEM(-#0007)

Is the prolix resistor connected to manual control temporarily when the electronic control system is out of order, until repair work be done.

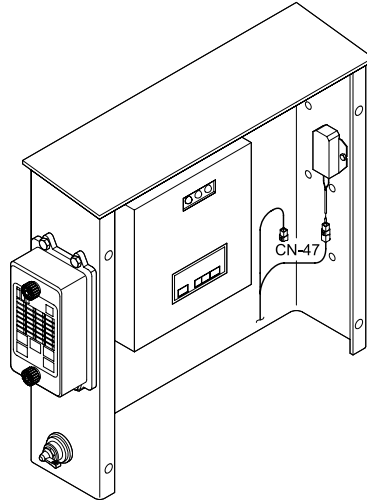

32075MS15

1. OPERATING PRINCIPLE WIRING DIAGRAM

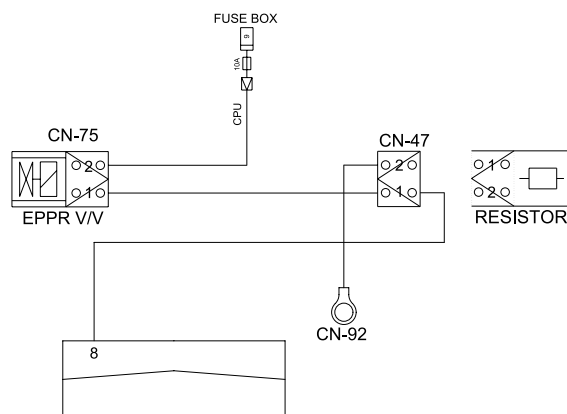

14075MS19

1) NORMAL

- EPPR valve supply specified amount of pilot pressure to the flow regulator of hydraulic pump and regulate hydraulic pump delivery amount depending upon the signal of CPU controller by selected mode.

2) EMERGENCY

- If prolix resistor is connected with the emergency connector when any abnormality occurs in NEW CAPO system, constant electric current from battery flows to EPPR valve so that EPPR valve can be fixed at the predetermined position.
- In this case excavator can be operated at an equivalent performance to S mode.

GROUP 13 MONITORING SYSTEM(-#0007)

1. OUTLINE

Monitoring system consists of the monitor part and switch part.

The monitor part gives warnings when any abnormality occurs in the machine and informs the condition of the machine.

Various select switches are built into the monitor panel, which act as the control portion of the machine control system.

2. CLUSTER

1) MONITOR PANEL

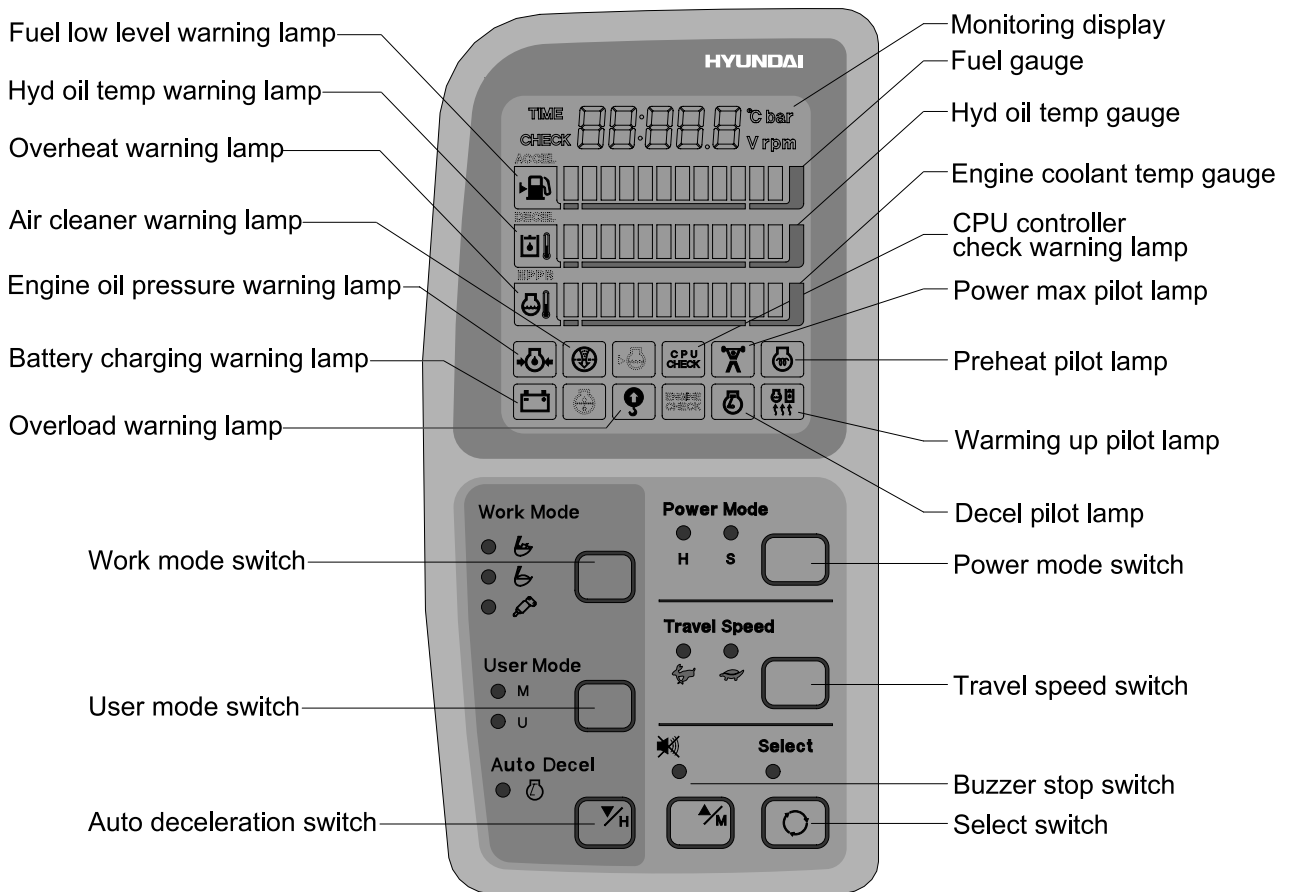

34075MS12

2) CLUSTER CHECK PROCEDURE

(1) Start key : ON

- ① Check monitor initial 5 seconds
 - a. All lamps light up.
 - b. Buzzer sound.
- ② Check monitor after 5 seconds : Indicate cluster version and machine condition
 - a. Cluster program version : CL : 1.4 ← Indicates program version 1.4 for 2 seconds.
 - b. Tachometer : 0rpm
 - c. Fuel gauge : All light up below appropriate level
 - d. Hydraulic temperature : All light up below appropriate level
 - e. Engine coolant temperature gauge : All light up below appropriate level
 - f. Warning lamp
 - ※ During start key **ON** the engine oil pressure lamp and battery charging lamp go on, but it is not abnormal.
 - ※ When engine coolant temperature below 30°C, the warming up lamp lights up.
- ③ Indicating lamp state
 - a. Work mode selection : General work
 - b. Power mode selection : S mode
 - c. User mode selection : No LED ON
 - d. Auto decel LED : ON
 - e. Travel speed pilot lamp : Low(Turtle)

(2) Start of engine

- ① Check machine condition
 - a. Tachometer indicates at present rpm
 - b. Gauge and warning lamp : Indicate at present condition.
 - ※ When normal condition : All warning lamp OFF
 - c. Work mode selection : General work
 - d. Power mode selection : S mode
 - e. User mode selection : No LED ON
 - f. Auto decel LED : ON
 - g. Travel speed pilot lamp : Low(Turtle)
- ② When warming up operation
 - a. Warming up lamp : ON
 - b. 10 seconds after engine started, engine speed increases to 1000rpm(Auto decel LED : ON)
 - ※ Others same as above ①.
- ③ When abnormal condition
 - a. The lamp lights up and the buzzer sounds.
 - b. If **BUZZER STOP** switch is pressed, buzzer sound is canceled but the lamp light up until normal condition.

3. CLUSTER CONNECTOR

No.	Signal	Input / Output
1	Power IG(24V)	Input(20~32V)
2	GND	Input(0V)
3	Serial-(RX)	Input(Vpp=12V)
4	Serial+(TX)	Output(Vpp=4V)

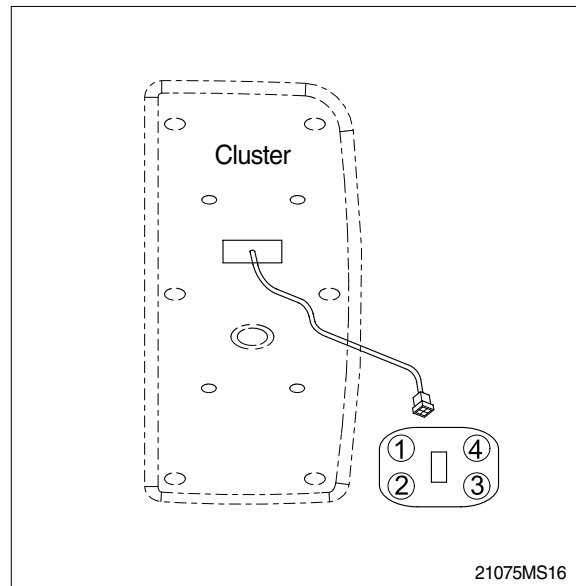

4. CLUSTER FUNCTION

1) MONITORING DISPLAY

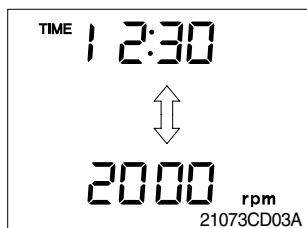

- (1) This displays the current time and machine information such as engine rpm, coolant/hydraulic oil temperature, hydraulic oil pressure and also error codes.

※ Refer to the page 5-33 for details.

2) FUEL GAUGE



- (1) This gauge indicates the amount of fuel in the fuel tank.

- (2) Fill the fuel when the white range or warning lamp  blinks.

※ **If the gauge illuminates the white range or warning lamp  blinks even though the machine is on the normal condition, check the electric device as that can be caused by the poor connection of electricity or sensor.**

3) HYDRAULIC OIL TEMPERATURE GAUGE

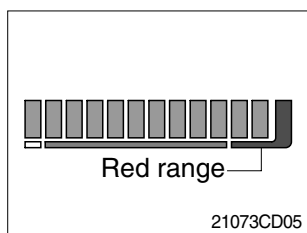

- (1) This indicates the temperature of coolant.

- White range : 30°C(86°F) below
- Green range : 30-105 °C(86-221°F)
- Red range : 105°C(221°F) above

- (2) The green range illuminates when operating.

- (3) Keep idling engine at low speed until the green range illuminates, before operation of machine.

- (4) When the red range illuminates, reduce the load on the system. If the gauge stays in the red range, stop the machine and check the cause of the problem.

4) ENGINE COOLANT TEMPERATURE GAUGE

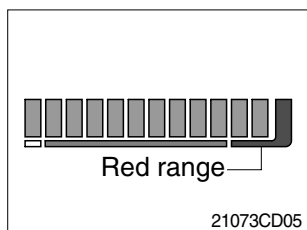

- (1) This indicates the temperature of coolant.

- White range : 30°C(86°F) below
- Green range : 30-105 °C(86-221°F)
- Red range : 105°C(221°F) above

- (2) The green range illuminates when operating.

- (3) Keep idling engine at low speed until the green range illuminates, before operation of machine.

- (4) When the red range illuminates, turn OFF the engine, check the radiator and engine.

5) FUEL LOW LEVEL WARNING LAMP

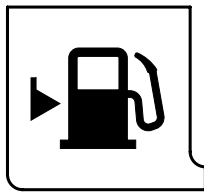

21073CD04A

(1) This lamp blinks and the buzzer sounds when the level of fuel is below 67 l (17.7U.S. gal).

(2) Fill the fuel immediately when the lamp blinks.

6) HYDRAULIC OIL TEMPERATURE WARNING LAMP

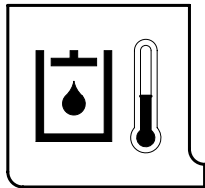

21073CD05A

(1) This warning lamp operates and the buzzer sounds when the temperature of hydraulic oil is over 105°C (221°F).

(2) Check the hydraulic oil level when the lamp blinks.

(3) Check for debris between oil cooler and radiator.

7) OVERHEAT WARNING LAMP

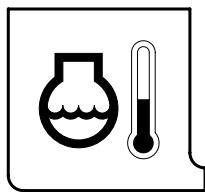

21073CD05A

(1) This lamp blinks and the buzzer sounds when the temperature of coolant is over the normal temperature 105°C (221°F) .

(2) Check the cooling system when the lamp blinks.

8) ENGINE OIL PRESSURE WARNING LAMP

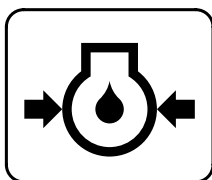

21073CD07

(1) This lamp blinks and the buzzer sounds after starting the engine because of pressure.

(2) If the lamp blinks during engine operation, shut OFF engine immediately. Check oil level.

9) AIR CLEANER WARNING LAMP

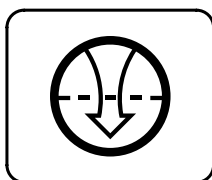

21073CD08

(1) This lamp is operated by the vacuum caused inside when the filter of air cleaner is clogged which supply air to the engine.

(2) Check the filter and clean or replace it when the lamp blinks.

10) MCU CHECK WARMING LAMP

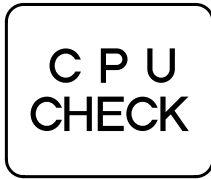

21073CD10

- (1) Communication problem between MCU and cluster makes the lamp blinks and the buzzer sounds.
- (2) Check if any fuse for MCU burnt off.
- (3) If not check the communication line between them.

11) BATTERY CHARGING WARNING LAMP

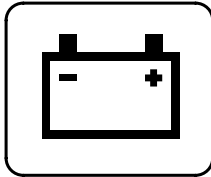

21073CD10

- (1) This lamp blinks and the buzzer sounds when the starting switch is ON, it is turned OFF after starting the engine.
- (2) Check the battery charging circuit when this lamp blinks, during engine operation.

12) OVERLOAD WARNING LAMP

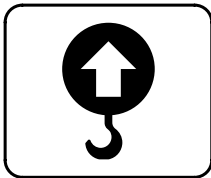

21073CD15

- (1) When the machine is overload, the overload warning lamp blinks during the overload switch ON.

13) POWER MAX PILOT LAMP



21073CD11

- (1) The lamp will be ON when pushing power max switch on the LH RCV lever.

14) ONE TOUCH DECEL PILOT LAMP

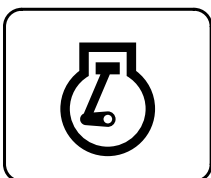

21073CD17

- (1) Operating auto decel or one touch decel makes the lamp ON.
- (2) The lamp will be ON when pushing one touch decel switch on the LH RCV lever.

15) WARMING UP PILOT LAMP

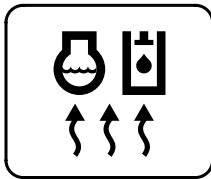

21073CD18

- (1) This lamp is turned ON when the coolant temperature is below 30°C (86 °F).
- (2) The automatic warming up is cancelled when the engine coolant temperature is above 30 °C, or when 10 minutes have passed since starting.

16) PREHEAT PILOT LAMP

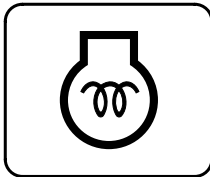



21073CD12

- (1) Turning the start key switch ON position starts preheating in cold weather.
- (2) Start the engine as this lamp is OFF.

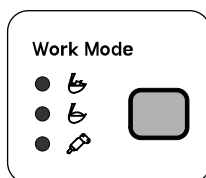
17) WORK MODE SWITCH



21073CD20

- (1) This switch is to select the machine operation mode, which shifts from general operation mode to heavy operation mode and breaker mode in a row by pressing the switch.
 -  : Heavy duty work mode
 -  : General work mode
 -  : Breaker operation mode
- ※ Refer to the page 5-5 for details.

18) USER MODE SWITCH

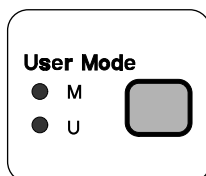

34075MS13

- (1) This switch is to select the memory sets, at which you can change the engine and pump power and memorize it into MI and MII mode for your preference.
- ※ Refer to the page 5-5 for details.

19) AUTO DECELERATION SWITCH

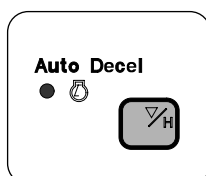

21073CD22

- (1) This switch is used to actuate the auto deceleration function so the engine speed is lowered automatically when all control levers and pedals are at neutral position to save the fuel.
 - Light ON : Auto deceleration function is selected.
 - Light OFF : Auto deceleration function is cancelled so that the engine speed increased to previous setting value.
- (2) Operating the auto deceleration function makes the decel indicate lamp on the LCD panel ON.

20) POWER MODE SWITCH

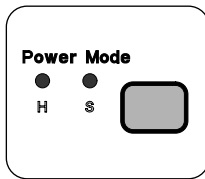

21073CD23

- (1) The lamp of selected mode is turned ON by pressing the switch(), when selecting the mode to use.
 - H : This is used for high power work.
 - S : This is used for standard power work.

21) TRAVEL SPEED CONTROL SWITCH

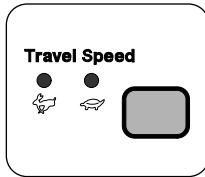

21073CD24

- (1) This switch is to control the travel speed which is changed to high speed(Rabbit mark) by pressing the switch and low speed(Turtle mark) by pressing again.

22) BUZZER STOP SWITCH

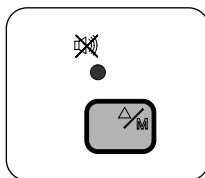

21073CD25

- (1) When the starting switch is turned ON first, normally the alarm buzzer sounds for 2 seconds during lamp check operation.
- (2) The red lamp lights ON and the buzzer sounds when the machine has a problem.
In this case, press this switch and buzzer stops, but the red lamp lights until the problem is cleared.

23) SELECT SWITCH

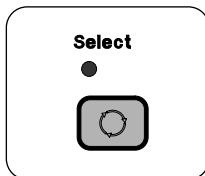

21073CD25A

- (1) This switch is used to select the monitor display function.
※ **Refer to the page 5-33 for details.**
- (2) If the switch is pressed for 3 seconds in time display mode, it is selected time adjusting function, as below.
 - Hour by auto decel switch
 - Minute by buzzer stop switch.
- (3) After time set, the switch is pressed, it is returned clock.

5. MONITORING DISPLAY

1) OUTLINE

Information of machine performance as monitored by the MCU can be displayed on the cluster when the operator selects a display mode by touching **SELECT** switch alone or with **BUZZER STOP** switch on the cluster as below.

Display group	How to select display mode		Name	Display on the cluster	
	Group selection	Display mode selection			
Group 0 (Default)	Way 1 Key switch ON or START Way 2 Touch AUTO DECEL switch while pressing BUZZER STOP at group 1~4.	Initial	Engine rpm	950 rpm	
		Touch SELECT 1 time	Time	TIME 12:30	
		Touch SELECT 2 times	Power shift pressure (EPPR valve)	EP: 10 bar	
		Touch SELECT 3 times	MCU model & version	32C 10	
		Touch SELECT 4 times	Option (Only when a pressure sensor is installed)	Front pump pressure	P1: 100 bar
		Touch SELECT 5 times		Rear pump pressure	P2: 200 bar
		Touch SELECT 6 times		Pilot pressure	P3: 30 bar
Group 1 (Volt, temp, EPPR press, version)	Touch SELECT switch once while pressing BUZZER STOP . In this group SELECT LED ON	Default	Battery voltage(V)	b: 24.8 V	
		Touch SELECT 1 time	Potentiometer voltage(V)	Pa: 2.5 V	
		Touch SELECT 2 times	Accel dial voltage(V)	dL: 3.8 V	
		Touch SELECT 3 times	Hydraulic oil temperature(°C)	Hd: 50 °C	
		Touch SELECT 4 times	Coolant temperature(°C)	Ct: 85 °C	
Group 2 (Error code)	Touch SELECT switch twice while pressing BUZZER STOP . In this group BUZZER STOP LED blinks	Default	Current error	CHECK Er: 03	
		Touch SELECT 1 time	Recorded error (Only key switch ON)	TIME Er: 03	
		Press down(▼) & SELECT at the same time	Recorded error deletion (Only key switch ON)	TIME Er: 00	
Group 3 (Switch input)	Touch SELECT switch 3 times while pressing BUZZER STOP . In this group SELECT LED blinks at 0.5sec interval	Default	Pump prolix switch	PP: on or off	
		Touch SELECT 1 time	Auto decel pressure switch	dP: on or off	
		Touch SELECT 2 times	Power boost switch	Pb: on or off	
		Touch SELECT 3 times	Travel oil pressure switch	oP: on or off	
		Touch SELECT 4 times	One touch decel switch	od: on or off	
		Touch SELECT 5 times	Travel alarm switch	br: on or off	
		Touch SELECT 6 times	Preheat switch	PH: on or off	

Display group	How to select display mode		Name	Display on the cluster
	Group selection	Display mode selection		
Group 4 (Output)	Touch SELECT switch 4 times while pressing BUZZER STOP . In this group SELECT LED blinks at 1sec interval	Default	Hourmeter	Ho:ON or OFF
		Touch SELECT 1 time	Neutral relay (Anti-restart relay)	nr:ON or OFF
		Touch SELECT 2 times	Travel speed solenoid	tS:ON or OFF
		Touch SELECT 3 times	Power boost solenoid (2-stage relief solenoid)	PS:ON or OFF
		Touch SELECT 4 times	Boom priority solenoid	bS:ON or OFF
		Touch SELECT 5 times	Travel alarm	AL:ON or OFF
		Touch SELECT 6 times	Max flow cut off solenoid	FS:ON or OFF
		Touch SELECT 7 times	Preheat relay	PR:ON or OFF

※ By touching **SELECT** switch once while pressing **BUZZER STOP**, display group shifts.

Example : Group 0 → 1 → 2 → 3 → 4 → 0

2) DESCRIPTION OF MONITORING DISPLAY

Group	Display	Name	Description
Group 0	2250 rpm	Engine speed	It displays current engine speed detected by engine speed sensor from 500 to 3000rpm. Range : 500~3000rpm by 10rpm
	TIME 12 : 30	Time	It displays current time(12 is hour and 30 is minute) Range : Hour(1~12), minute(00~59)
	EP : 10bar	Power shift pressure of EPPR valve	It shows that pump power shift pressure of EPPR valve being controlled by the MCU is 10bar. Range : 00~50bar by 1bar
	34 : C1.0	Model and MCU program version	It shows that machine model(R340LC-7) and the program version of the MCU is 1.0 Version display range : 0.0~9.9 by 0.1
	P1 : 100bar (Option)	Front pump pressure	It displays front pump pressure of 100bar which is detected by pressure sensor. Range : 000~500bar by 10bar
	P2 : 200bar (Option)	Rear pump pressure	It displays rear pump pressure of 200bar which is detected by pressure sensor. Range : 000~500bar by 10bar
	P3 : 30bar (Option)	Pilot pump pressure	It displays pilot pump pressure of 30bar which is detected by pressure sensor. Range : 00~50bar by 1bar
Group 1	b24 : 8V	Battery voltage	It shows that battery power of 24.8V is supplied into MCU. Range : 00.0~48.0V by 0.1V
	Po : 2.5V	Potentiometer voltage	It shows that potentiometer signal voltage is 2.5V. Range : 0.0~5.0V by 0.1V
	dL : 3.8V	Accel dial voltage	It shows that accel dial signal voltage is 3.8V. Range : 0.0~5.0V by 0.1V
	Hd : 50° C	Hydraulic oil temperature	It shows that hydraulic oil temperature detected by temperature sensor is 50°C. Range : 0~150°C by 1°C
	Ct : 85° C	Coolant temperature	It shows that coolant oil temperature detected by temperature sensor is 50°C. Range : 0~150°C by 1°C

Group	Display	Name	Description
Group 2	CHECK Er : 03	Current error	It shows that current error of 03(Short circuit in pump EPPR valve system) is diagnosed by self diagnosis system in the CPU controller. If more than 2 errors, when pressing ▼ or ▲ switch, other error codes show. Range : 00~58
	TIME Er : 03	Recorded error	It shows recorded error code of 03 which is diagnosed before. If more than 2 error codes, when pressing ▼ or ▲ switch, other error codes show. Range : 00~58
	TIME Er : 00	Recorded error deletion	It shows all recorded error codes are removed in the MCU controller memory.
Group 3	PP : on or oFF	Pump prolix switch	PP : on Shows that pump prolix switch is turned on(At emergency position). PP : oFF Shows that pump prolix switch is turned off(At normal position).
	dP : on or oFF	Auto decel pressure switch	dP : on Shows that auto decel pressure switch is pressed on (No operation of control lever). dP : oFF Shows that auto decel pressure switch is released off (Operation of control lever).
	Pb : on or oFF	Power boost switch	Pb : on Shows that power boost switch is pressed on (Activated). Pb : oFF Shows that power boost switch is released off (Canceled).
	oP : on or oFF	Travel oil pressure switch	oP : on Shows that travel oil pressure switch is pressed on (No operation of travel control lever). oP : oFF Shows that travel oil pressure switch is released off (Operation of travel control lever).
	od : on or oFF	One touch decel switch	od : on Shows that one touch decel switch is pressed. od : oFF Shows that one touch decel switch is released.
	br : on or oFF	Travel alarm switch	br : on Shows that travel alarm function is selected. br : oFF Shows that travel alarm function is canceled.
	PH : on or oFF	Preheat switch	PH : on Shows that preheat switch is pressed. PH : oFF Shows that preheat switch is released.

Group	Display	Name	Description
Group 4	Ho : on or oFF	Hourmeter	Ho : on Shows that hourmeter is activated by MCU. Ho : oFF Shows that hourmeter is turned off.
	nr : on or oFF	Neutral relay (Anti-restart relay)	nr : on Shows that neutral relay for anti-restarting function is activated(Engine start is possible). nr : oFF Shows that neutral relay is turned off to disable the engine restart.
	ts : on or oFF	Travel speed solenoid	ts : on Shows that travel speed solenoid is activated (High speed). ts : oFF Shows that travel speed solenoid is released (Low speed).
	PS : on or oFF	Power boost solenoid	PS : on Shows that power boost solenoid is activated to maximize the power(Power up). PS : oFF Shows that power boost solenoid is turned off(Cancel the power boost function).
	bs : on or oFF	Boom priority solenoid	bs : on Shows that boom priority solenoid is activated. bs : oFF Shows that boom priority solenoid is released.
	Ru : on or oFF	Travel alarm	Ru : on Shows that travel buzzer is activated. Ru :oFF Shows that travel buzzer is canceled.
	FS : on or oFF	Max flow cut off solenoid	FS : on Shows that max flow cut off solenoid is activated. FS : oFF Shows that max flow cut off solenoid is released.
	PR : on or oFF	Preheat relay	PR : on Shows that preheat relay is activated. PR : oFF Shows that preheat relay is released.

GROUP 13 MONITORING SYSTEM(#0008-)

1. OUTLINE

Monitoring system consists of the monitor part and switch part.

The monitor part gives warnings when any abnormality occurs in the machine and informs the condition of the machine.

Various select switches are built into the monitor panel, which act as the control portion of the machine control system.

2. CLUSTER

1) MONITOR PANEL

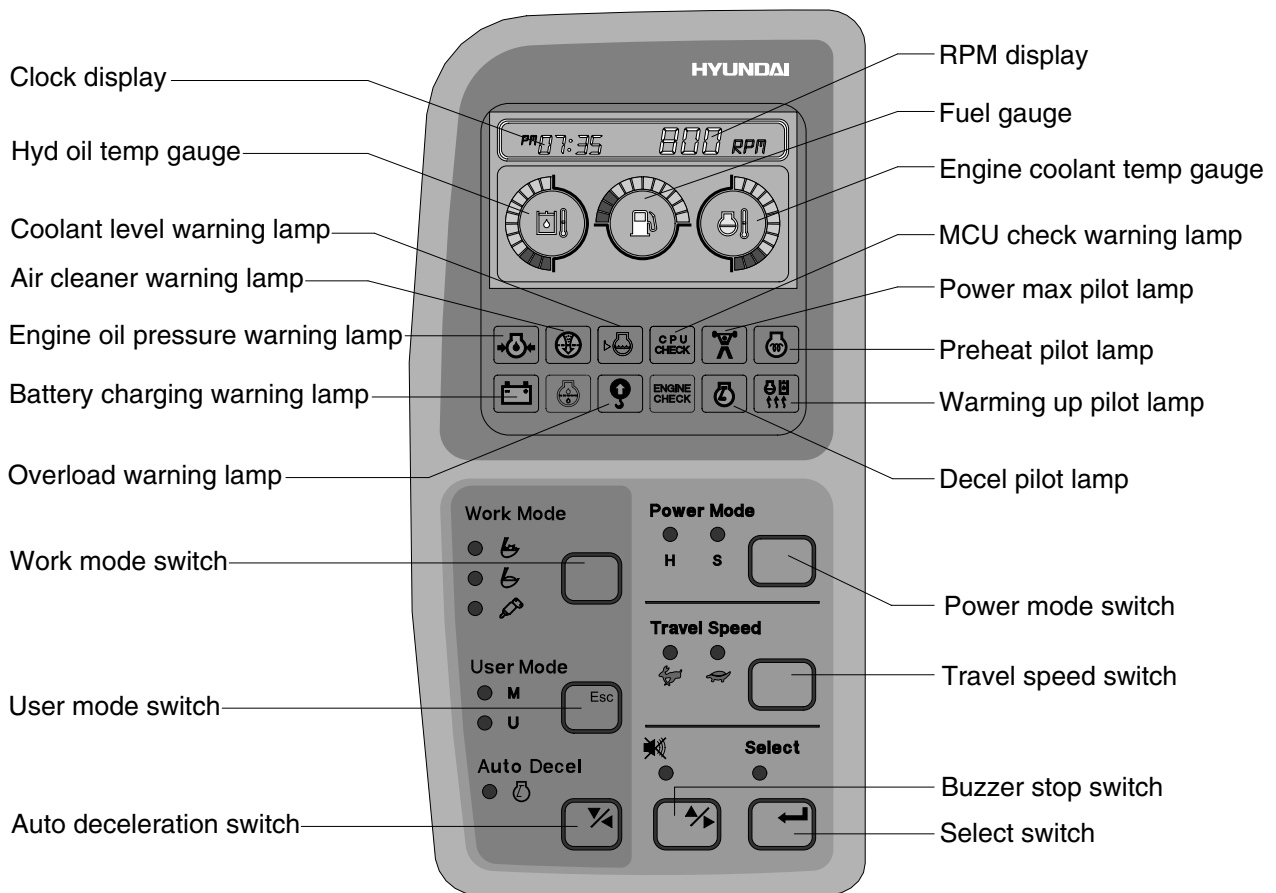

30075MS01

2) CLUSTER CHECK PROCEDURE

(1) Start key : ON

- ① Check monitor initial 5 seconds
 - a. All lamps light up.
 - b. Buzzer sound.
- ② Check monitor after 5 seconds : Indicate cluster version and machine condition
 - a. Cluster program version : 「1.00」 ← Indicates program version 「1.00」 for 5 seconds.
 - b. Tachometer : 0rpm
 - c. Fuel gauge : All light up below appropriate level
 - d. Hydraulic temperature : All light up below appropriate level
 - e. Engine coolant temperature gauge : All light up below appropriate level
 - f. Warning lamp
 - ※ During start key **ON** the engine oil pressure lamp and battery charging lamp go on, but it is not abnormal.
 - ※ When engine coolant temperature below 30°C, the warming up lamp lights up.
- ③ Indicating lamp state
 - a. Work mode selection : General work
 - b. Power mode selection : S mode
 - c. User mode selection : No LED ON
 - d. Auto decel LED : ON
 - e. Travel speed pilot lamp : Low(Turtle)

(2) Start of engine

- ① Check machine condition
 - a. Tachometer indicates at present rpm
 - b. Gauge and warning lamp : Indicate at present condition.
 - ※ When normal condition : All warning lamp OFF
 - c. Work mode selection : General work
 - d. Power mode selection : S mode
 - e. User mode selection : No LED ON
 - f. Auto decel LED : ON
 - g. Travel speed pilot lamp : Low(Turtle)
- ② When warming up operation
 - a. Warming up lamp : ON
 - b. 10 seconds after engine started, engine speed increases to 1000rpm(Auto decel LED : ON)
 - ※ Others same as above ①.
- ③ When abnormal condition
 - a. The lamp lights up and the buzzer sounds.
 - b. If **BUZZER STOP** switch is pressed, buzzer sound is canceled but the lamp light up until normal condition.

3. CLUSTER CONNECTOR

No.	Signal	Input / Output
1	Power IG(24V)	Input(20~32V)
2	GND	Input(0V)
3	Serial-(RX)	Input(Vpp=12V)
4	Serial+(TX)	Output(Vpp=4V)

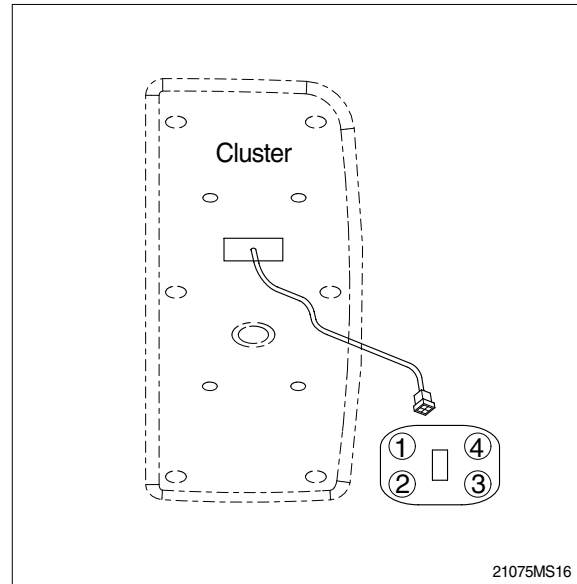

4. CLUSTER FUNCTION

1) LCD main operation display

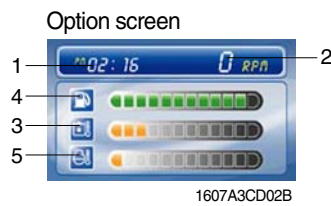
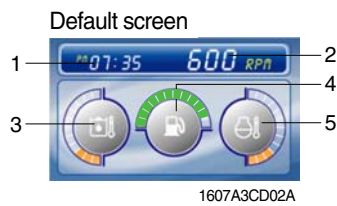

- 1 Time display
- 2 RPM display
- 3 Hydraulic oil temperature gauge
- 4 Fuel level gauge
- 5 Engine coolant temperature gauge

(1) Time display



- ① This displays the current time.

※ Refer to the page 5-45 to set time for details.

(2) RPM display



- ① This displays the engine rpm.

(3) Hydraulic oil temperature gauge

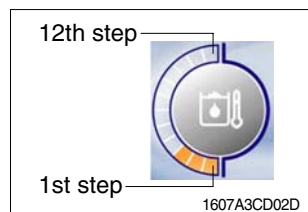

- ① This gauge indicates the temperature of hydraulic oil in 12 step gauge.

- 1st step : Below 30°C(86°F)
- 2nd~10th step : 30-105 °C(86-221°F)
- 11th~12th step : Above 105°C(221°F)

- ② The gauge between 2nd and 10th steps illuminates when operating.
- ③ Keep idling engine at low speed until the gauge between 2nd and 10th steps illuminates, before operation of machine.
- ④ When the gauge of 11th and 12th steps illuminates, reduce the load on the system. If the gauge stays in the 11th~12th steps, stop the machine and check the cause of the problem.

(4) Fuel level gauge

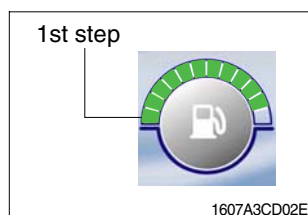

- ① This gauge indicates the amount of fuel in the fuel tank.

- ② Fill the fuel when the 1st step or fuel icon blinks in red.

※ If the gauge illuminates the 1st step or fuel icon blinks in red even though the machine is on the normal condition, check the electric device as that can be caused by the poor connection of electricity or sensor.

(5) Engine coolant temperature gauge

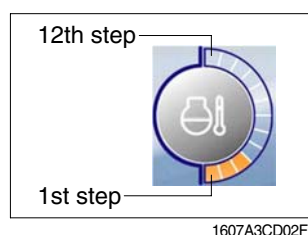

- ① This gauge indicates the temperature of coolant in 12 step gauge.

- 1st step : Below 30°C(86°F)
- 2nd~10th step : 30-105 °C(86-221°F)
- 11th~12th step : Above 105°C(221°F)

- ② The gauge between 2nd and 10th steps illuminates when operating.
- ③ Keep idling engine at low speed until the gauge between 2nd and 10th steps illuminates, before operation of machine.
- ④ When the gauge of 11th and 12th steps illuminates, turn OFF the engine, check the radiator and engine.

3) Warning of main operation screen

(1) Warning display

① Engine coolant temperature



- This lamp blinks and the buzzer sounds when the temperature of coolant is over the normal temperature 105°C (221°F) .
- Check the cooling system when the lamp blinks.

② Fuel level



- This lamp blinks and the buzzer sounds when the level of fuel is below 67 l (17.7 U.S. gal).
- Fill the fuel immediately when the lamp blinks.

③ Hydraulic oil temperature



- This warning lamp operates and the buzzer sounds when the temperature of hydraulic oil is over 105 °C (221 °F) .
- Check the hydraulic oil level when the lamp blinks.
- Check for debris between oil cooler and radiator.

④ All gauge



- This lamp blinks and the buzzer sounds when the all gauge is abnormal.
- Check the each system when the lamp blinks.

⑤ Communication error



- Communication problem between MCU controller and cluster makes the lamp blinks and the buzzer sounds.
- Check if any fuse for MCU burnt off.
If not check the communication line between them.





(2) Pop-up icon display

No	Switch	Selected mode	Display
1	Work mode switch	General work mode	
		Heavy duty work mode	
		Breaker operation mode	
2	Power mode switch	High power work mode	
		Standard power work mode	

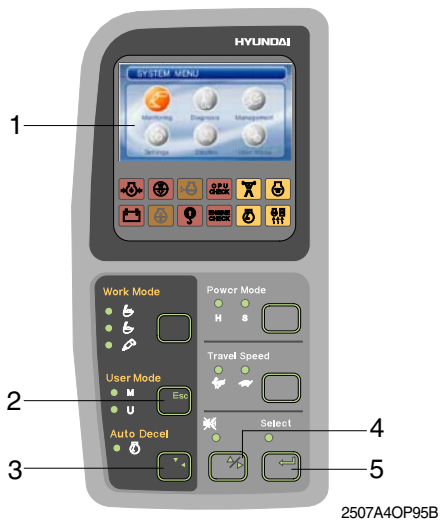
No	Switch	Selected mode	Display
3	Auto deceleration switch	Light ON	
		Light OFF	
4	Travel speed control switch	Low speed	
		High speed	







4) LCD

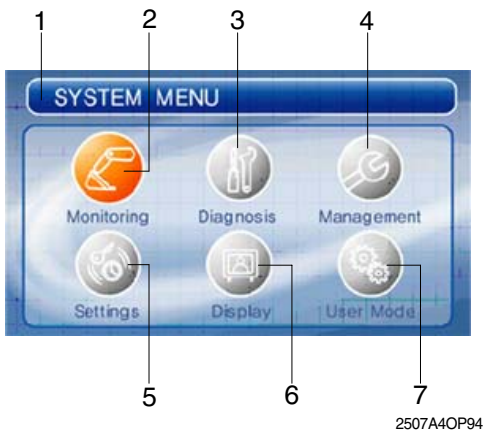

- 1  : LCD
- 2  : Escape,
Return to the previous menu
- 3  : Down/Left Direction
- 4  : Up/Right Direction
- 5  : Select(Enter)
Activate the currently chosen item

(1) Main menu



- 1  : Menu information
- 2  : Monitoring
- Equipment, Switch, Output
- 3  : Diagnosis
- Current error, Recorded error
- 4  : Maintenance
- 5  : Settings
- Time set, Dual mode
- System lock(Reserved)
- 6  : Display
- Operation skin, Brightness, Language
- 7  : User mode

(2) Display map

① Monitoring

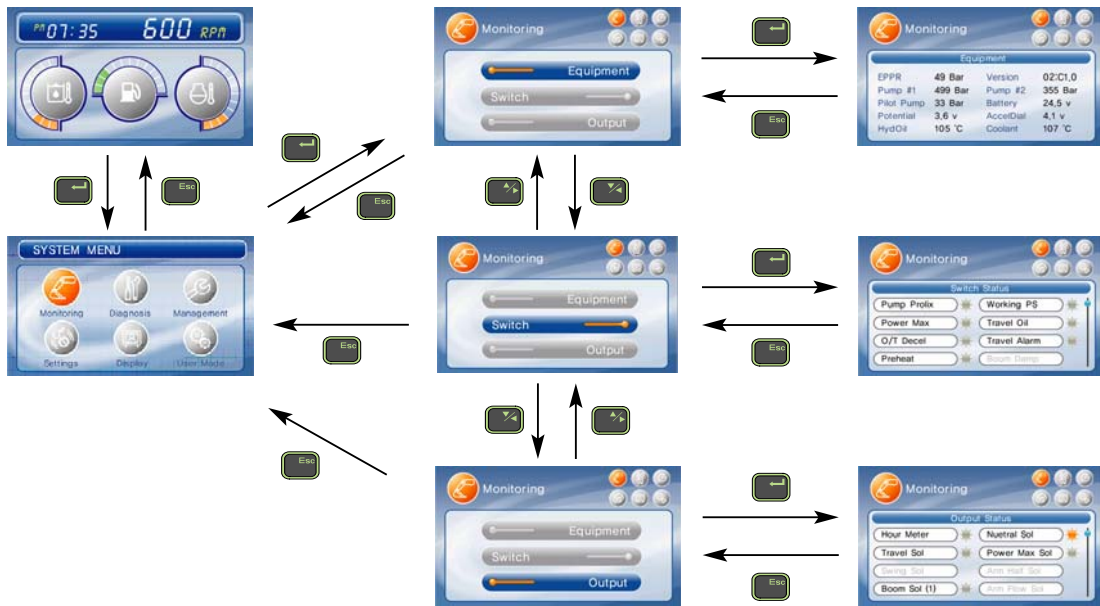

② Diagnosis

- If there are more than 2 error codes, each one can be displayed by pressing or switch respectively.

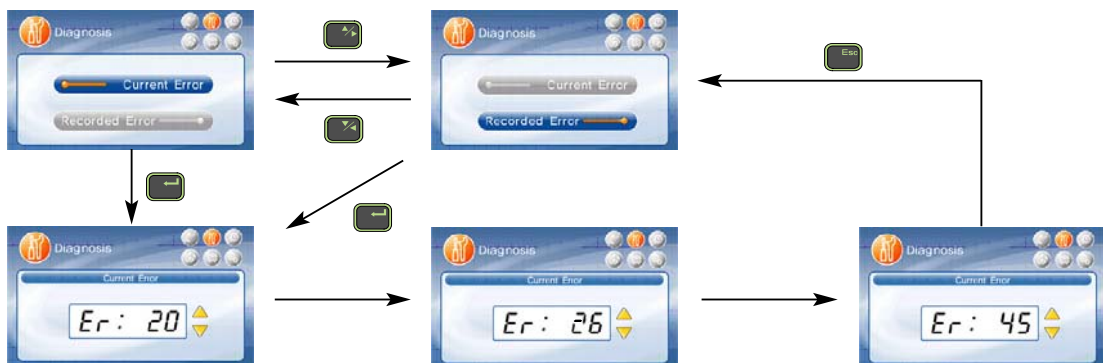

③ Maintenance

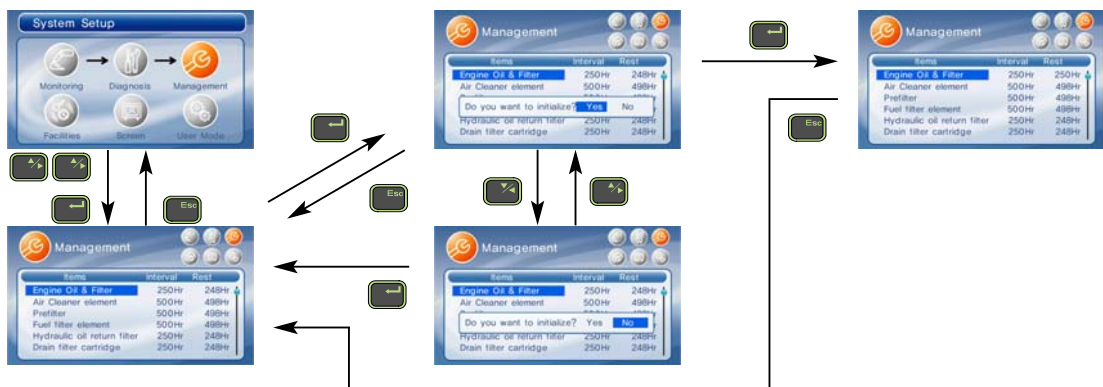

④ Setting

a. Time set



b. System lock - Reserved

c. Dual mode
- Changing the MCU mode



⑤ Display

a. Operation skin



b. Brightness

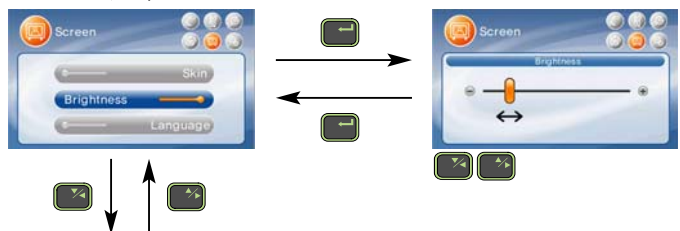

c. Language

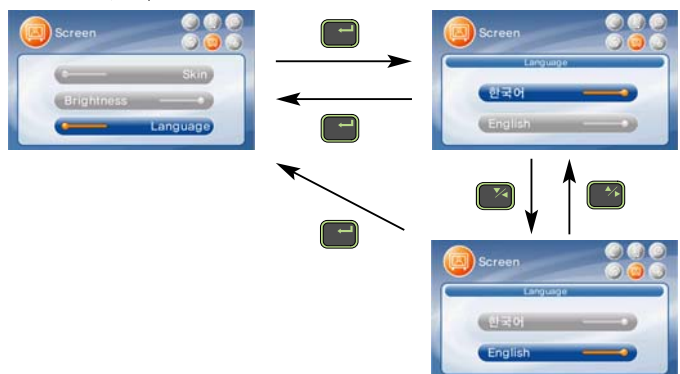

⑥ User mode

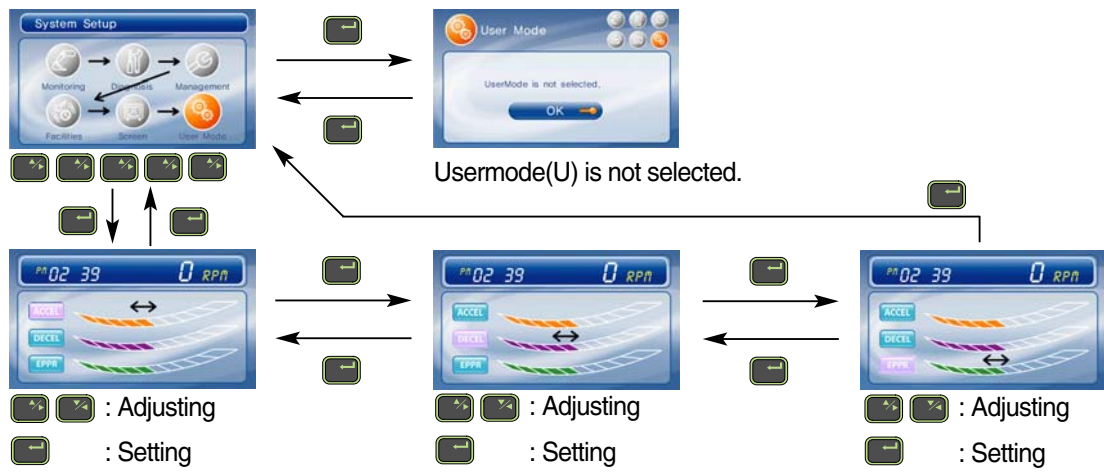

5) Warning and pilot lamp

(1) Engine oil pressure warning lamp

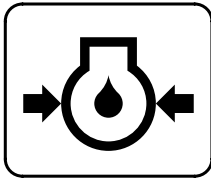

21073CD07

- ① This lamp blinks and the buzzer sounds after starting the engine because of the low oil pressure.
- ② If the lamp blinks during engine operation, shut OFF engine immediately. Check oil level.

(2) Air cleaner warning lamp

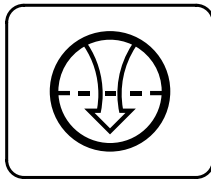

21073CD08

- ① This lamp blinks and the buzzer sounds when the filter of air cleaner is clogged.
- ② Check the filter and clean or replace it.

(3) MCU check warning lamp

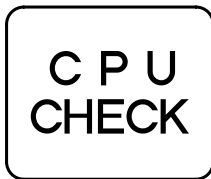

21073CD10

- ① If any fault code is received from MCU, this lamp blinks and the buzzer sounds.
- ② Check the communication line between MCU and cluster.

(4) Battery charging warning lamp

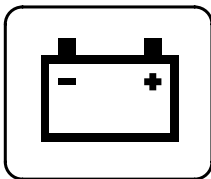

21073CD13

- ① This lamp blinks and the buzzer sounds when the starting switch is ON, it is turned OFF after starting the engine.
- ② Check the battery charging circuit when this lamp blinks during engine operation.

(5) Overload warning lamp (Option)

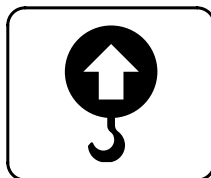

21073CD15

- ① When the machine is overload, the overload warning lamp blinks during the overload switch is ON.

(6) Power max pilot lamp

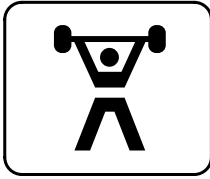

21073CD11

- ① The lamp will be ON when pushing power max switch on the LH RCV lever.

(7) Decel pilot lamp

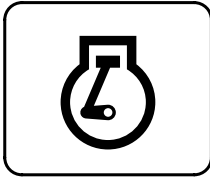

21073CD17

- ① Operating auto decel or one touch decel makes the lamp ON.
- ② The lamp will be ON when pushing one touch decel switch on the LH RCV lever.

(8) Warming up pilot lamp

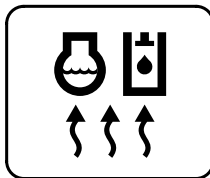

21073CD18

- ① This lamp is turned ON when the coolant temperature is below 30°C (86 °F).
- ② The automatic warming up is cancelled when the engine coolant temperature is above 30 °C, or when 10 minutes have passed since starting.

(9) Preheat pilot lamp

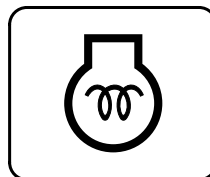



21073CD12

- ① Turning the start key switch ON position starts preheating in cold weather.
- ② Start the engine as this lamp is OFF.

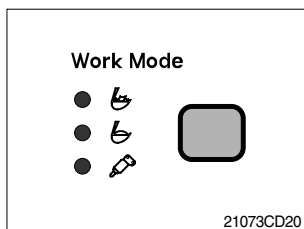
(10) Work mode switch



- ① This switch is to select the machine operation mode, which shifts from general operation mode to heavy operation mode and breaker mode in a row by pressing the switch.

-  : Heavy duty work mode
-  : General work mode
-  : Breaker operation mode

※ Refer to the page 5-5-2 for details.

(11) User mode switch

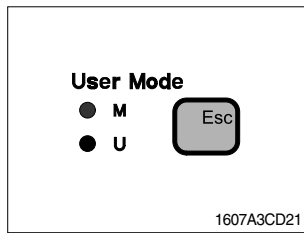

- ① This switch is to select the maximum power or user mode.
 - M : Maximum power
 - U : Memorizing operators preferable power setting.
- ※ Refer to the page 5-5-3 for details.

(12) Auto deceleration switch

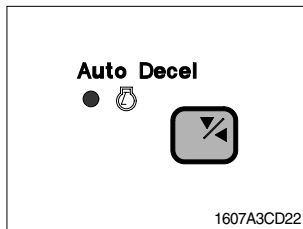

- ① This switch is used to actuate or cancel the auto deceleration function.
- ② When the switch actuated and all control levers and pedals are at neutral position, engine speed will be lowered automatically to save fuel consumption.
 - Light ON : Auto deceleration function is selected.
 - Light OFF : a. Auto deceleration function is cancelled so that the engine speed increased to previous setting value.
b. One touch decel function is available.

(13) Power mode switch

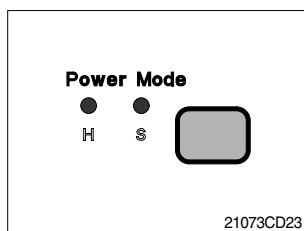

- ① The lamp of selected mode is turned ON by pressing the switch().
 - H : High power work.
 - S : Standard power work.

(14) Travel speed control switch

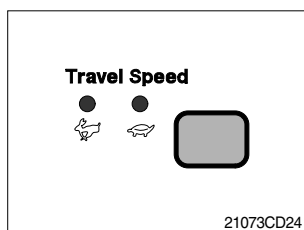

- ① This switch is to control the travel speed which is changed to high speed(Rabbit mark) by pressing the switch and low speed(Turtle mark) by pressing it again.

(15) Buzzer stop switch

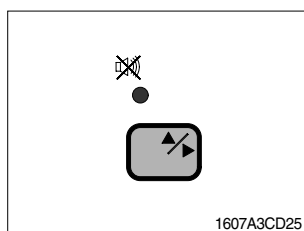

- ① When the starting switch is turned ON first, normally the alarm buzzer sounds for 2 seconds during lamp check operation.
- ② The red lamp lights ON and the buzzer sounds when the machine has a problem.
In this case, press this switch and buzzer stops, but the red lamp lights until the problem is cleared.

(16) Select switch

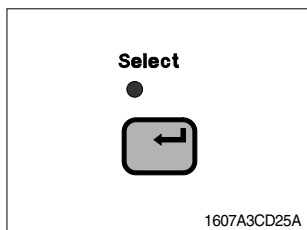

- ① This switch is used to enter main menu and sub menu of LCD.
- ※ Refer to the page 5-43 for details.

GROUP 13 FUEL WARMER SYSTEM

1. SPECIFICATION

- 1) Operating voltage : $24 \pm 4V$
- 2) Power : $200 \pm 50W$
- 3) Current : 15A

2. OPERATION

- 1) The current of fuel warmer system is automatically controlled without thermostat according to fuel temperature.
 - 2) At the first state, the 15A current flows to the fuel warmer and engine may be started in 1~2 minutes.
 - 3) If the fuel starts to flow, ceramic-disk in the fuel warmer heater senses the fuel temperature to reduce the current as low as 1.5A.
- So, fuel is protected from overheating by this mechanism.

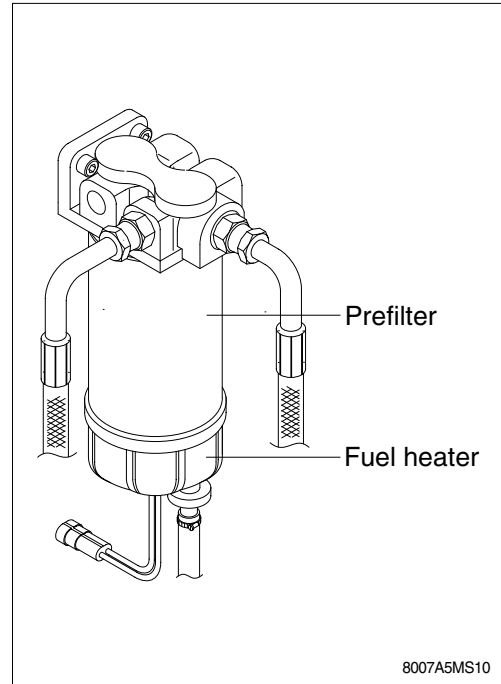

8007A5MS10

3. ELECTRIC CIRCUIT

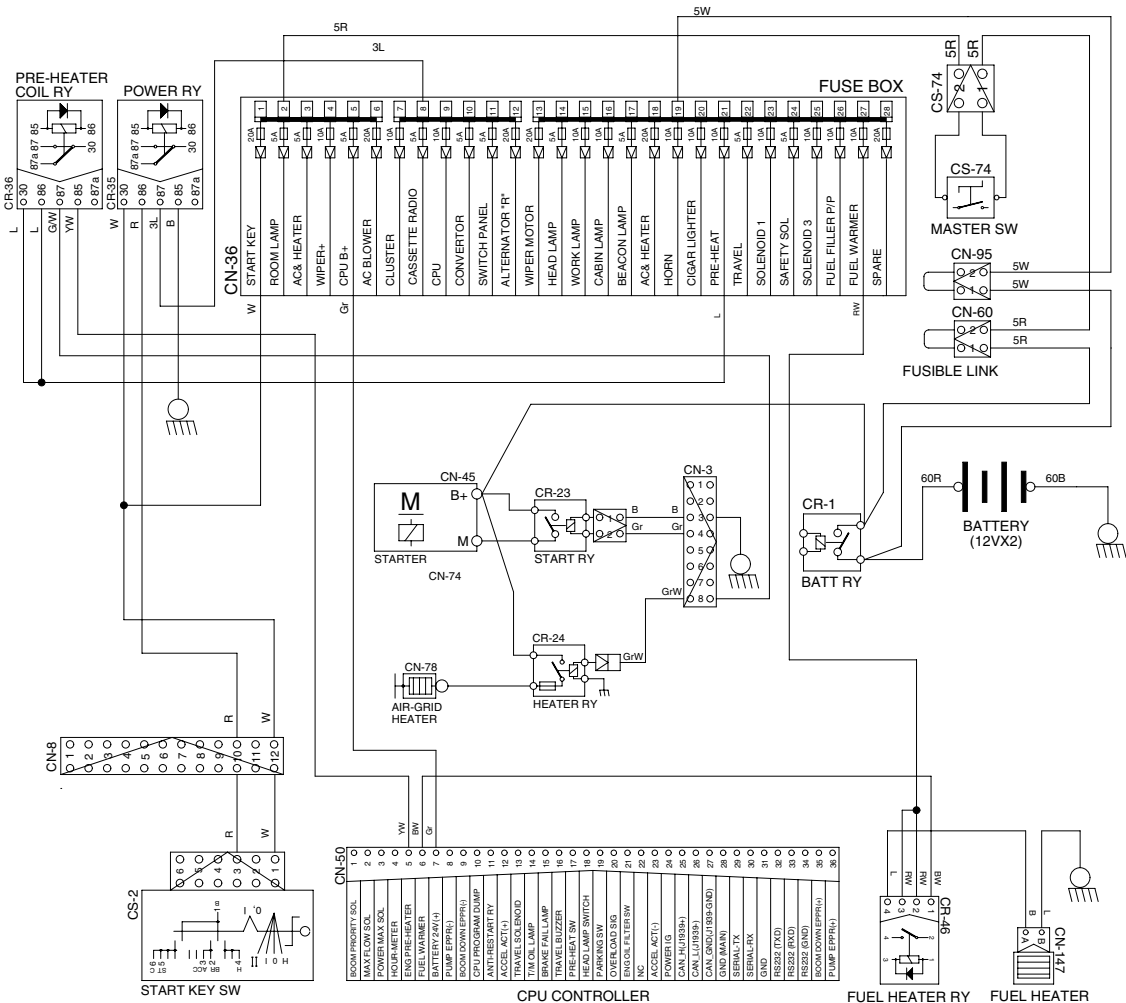

30007A5MS13