

## GROUP 5 SWING DEVICE

### 1. REMOVAL AND INSTALL OF MOTOR

#### 1) REMOVAL

(1) Lower the work equipment to the ground and stop the engine.

(2) Loosen the breather slowly to release the pressure inside the hydraulic tank.

**▲ Escaping fluid under pressure can penetrate the skin causing serious injury.**

※ When pipes and hoses are disconnected, the oil inside the piping will flow out, so catch it in oil pan.

(3) Disconnect pipe Assy (2, 3).

(4) Disconnect pilot line hoses (4, 5, 6, 7, 8, 9).

(5) Sling the swing motor assembly (1) and remove the swing motor mounting bolts (10).

- Motor device weight : 65 kg (140 lb)
- Tightening torque : 58.4 kgf · m  
(422.4 lbf · ft)

(6) Remove the swing motor assembly.

※ When removing the swing motor assembly, check that all the piping have been disconnected.

#### 2) INSTALL

(1) Carry out installation in the reverse order to removal.

(2) Bleed the air from the swing motor.

- ① Remove the air vent plug.
- ② Pour in hydraulic oil until it over flows from the port.
- ③ Tighten plug lightly.
- ④ Start the engine, run at low idling, and check oil come out from plug.
- ⑤ Tighten plug fully.

(3) Confirmed the hydraulic oil level and check the hydraulic oil leak or not.

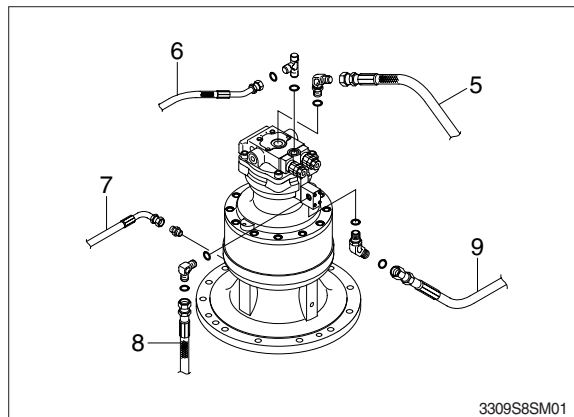
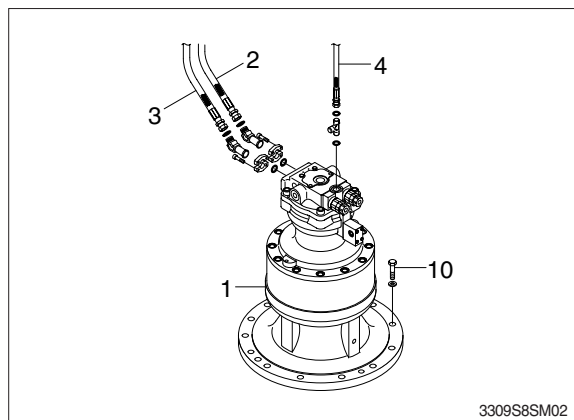

## 2. SWING MOTOR

### 1) STRUCTURE

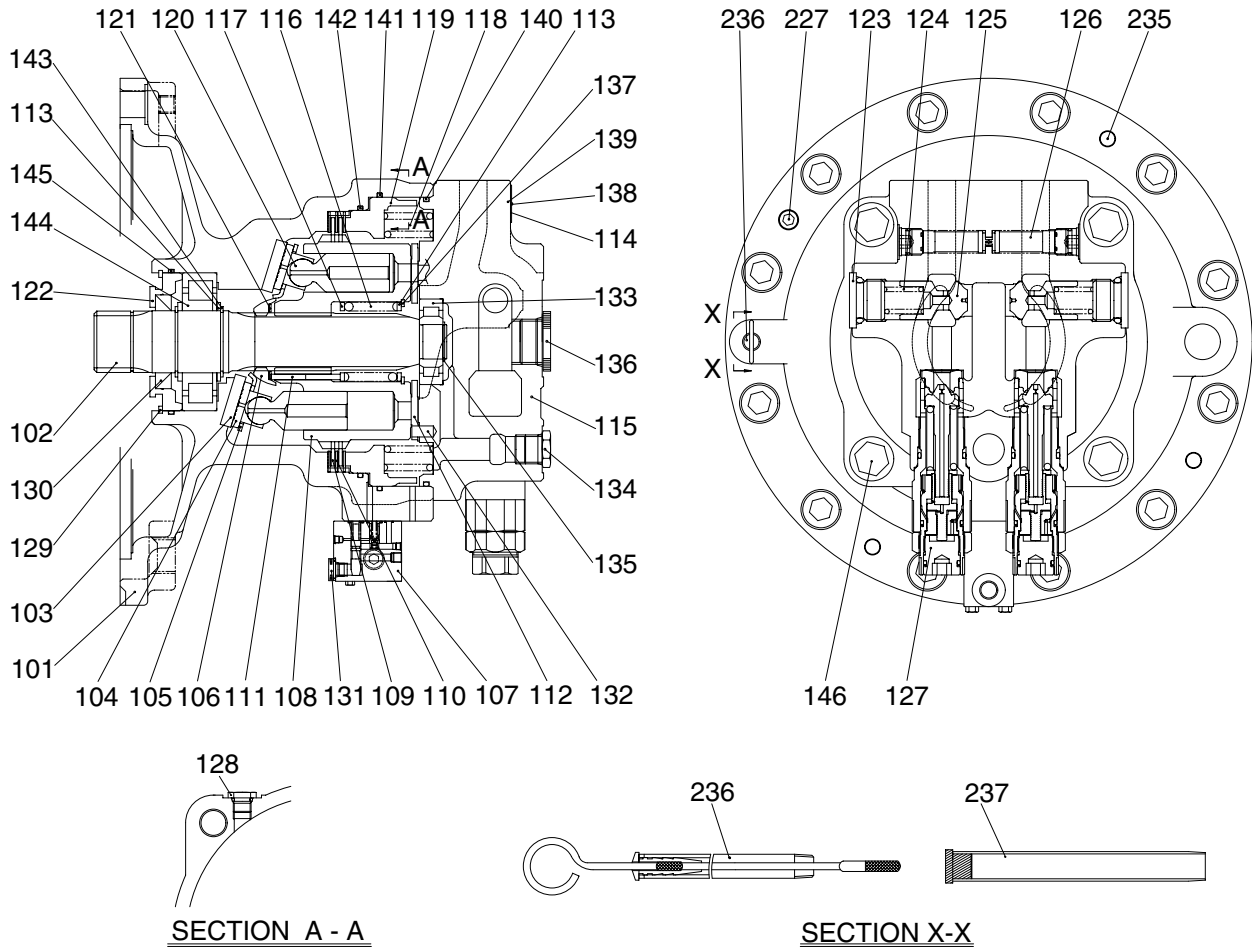

101	Casing A1	118	Brake spring	135	Ring snap
102	Drive shaft	119	Brake piston	136	Dust plug
103	Shoe plate	120	Piston	137	Ring snap
104	Shoe	121	Spacer F	138	Name plate
105	Retainer	122	Front cover	139	Rivet screw
106	Spherical bush	123	RO plug	140	O-ring
107	Brake valve	124	Spring	141	O-ring
108	Cylinder block	125	Plunger K	142	O-ring
109	Friction plate	126	S/reaction less valve	143	Ring snap
110	Separation pate	127	Relief valve	144	Roller bearing
111	Push rod	128	VP plug	145	O-ring
112	Valve plate	129	Ring snap	146	Socket bolt
113	Spacer	130	Oil seal	227	Socket bolt
114	VP plug	131	Dust plug	235	Pin
115	Valve casing	132	Pin spring	236	Level gauge
116	Cylinder spring	133	Roller bearing	237	Air breather assy
117	Spacer R	134	Dust plug		

32092SM02

## 2) DISASSEMBLY

- (1) Lift the motor out. Clean the motor in kerosene and dry with compressed air.
  - ※ To avoid dust inside the motor, mask all the ports of the motor with tapes.

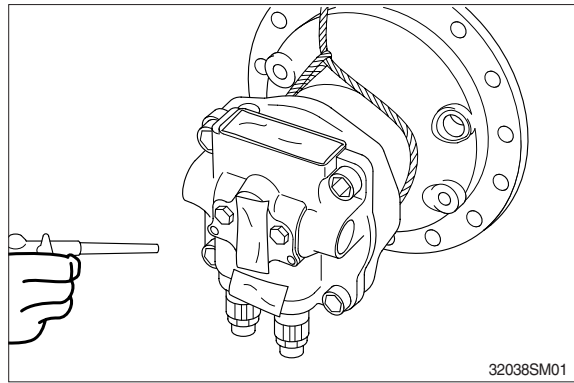

- (2) Loosen the drain plug to discharge oil in the casing (101).

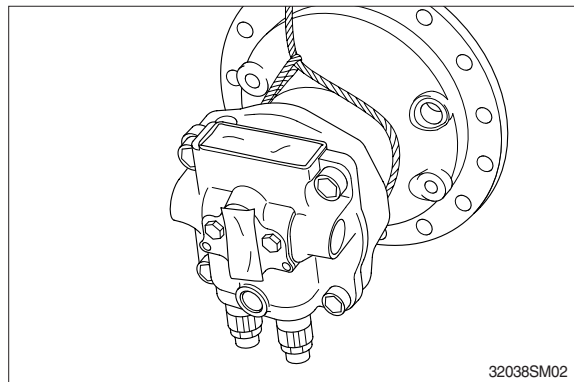

- (3) Fix the drive shaft (102) on the workbench with the end of output shaft down. Put matching marks on casing (101) and valve casing (303) for easy reassembly.

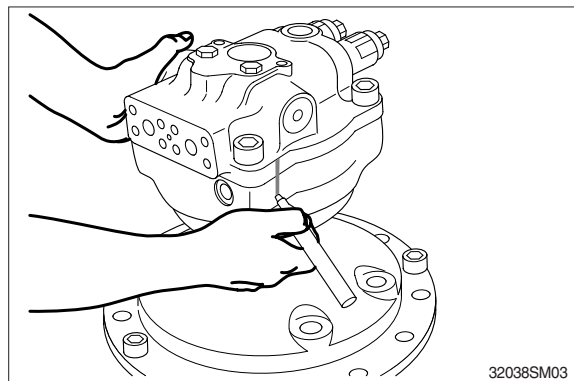

- (4) Remove the valve (107).

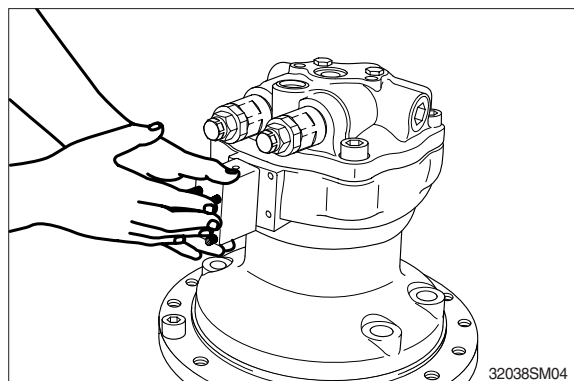

- (5) Remove the relief valve (127) from valve casing (115).

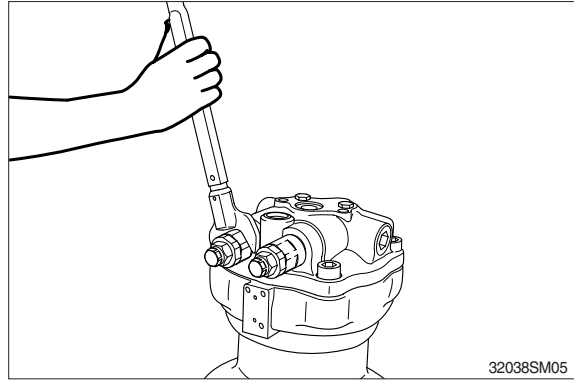

- (6) Remove plug (123) from valve casing (115) and spring (124), plunger (125).  
※ Be careful not to damage the plunger seat assembly.

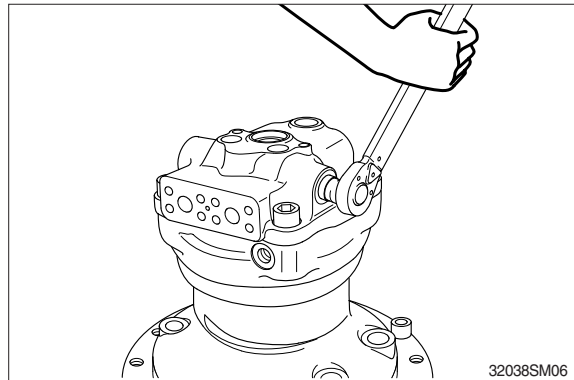

- (7) Remove valve casing (115) from casing (101). Then, remove the valve plate (112) from valve casing (115) with care.

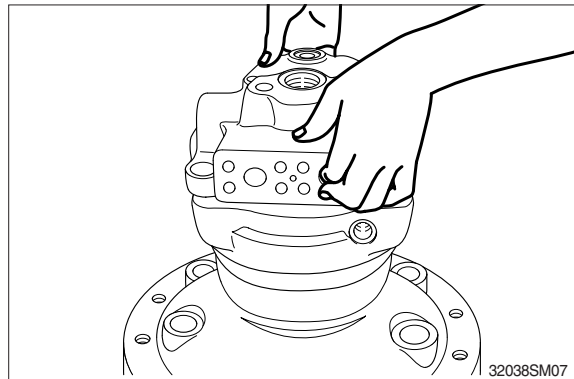

- (8) Remove the brake spring (118) from brake piston (119).

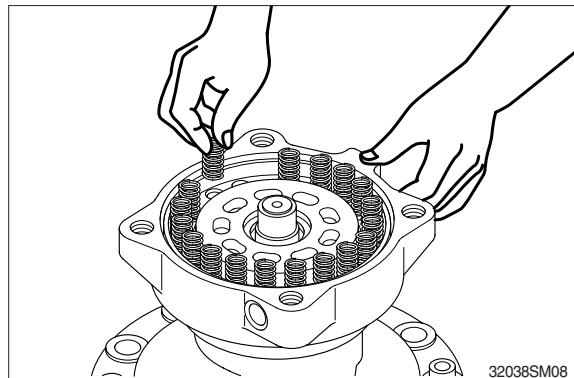

(9) Remove brake piston (119) from casing (101).

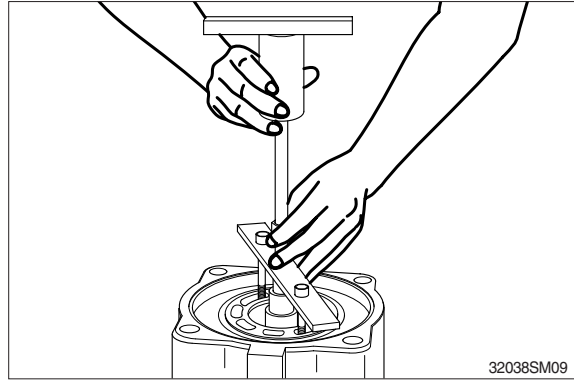

(10) Remove the cylinder (108) from the output shaft (102) with the motor positioned horizontally. Remove piston (104, 120), retainer (105), spherical bush (106), spacer (121) and shoe plate (103).

※ If shoe plate would not removed easily, try again after procedure (14).

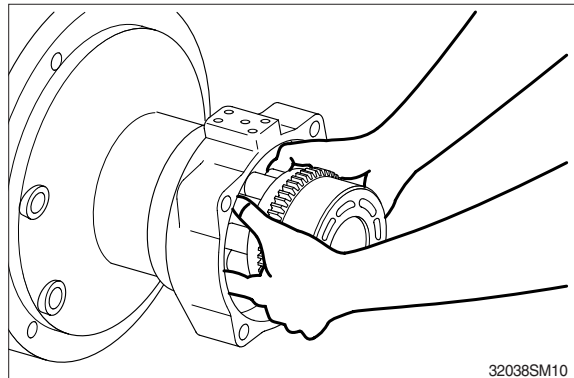

(11) Remove friction plate (109) and separate plate (110) from casing (101).

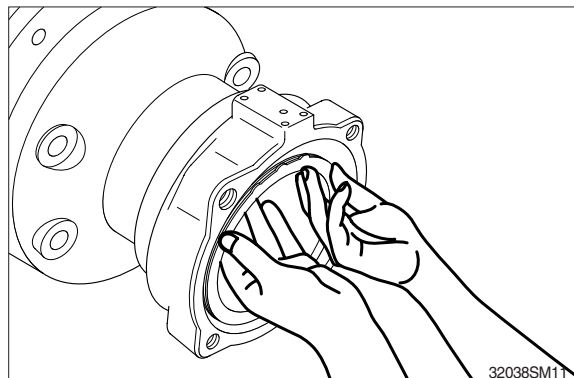

(12) Remove snap ring (129) with pillar and remove the front cover (122) from casing (101).

※ Front cover could be removed with sliding shaft if necessary.

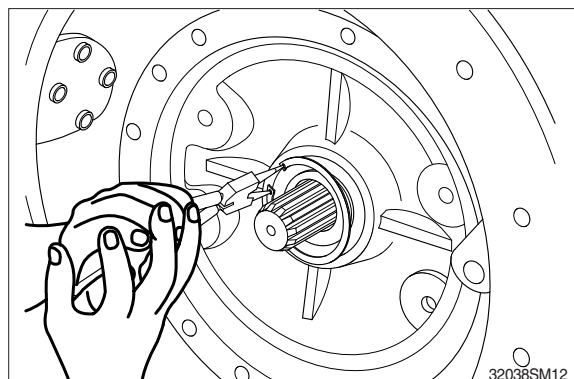

(13) Remove drive shaft (102) from casing (101).

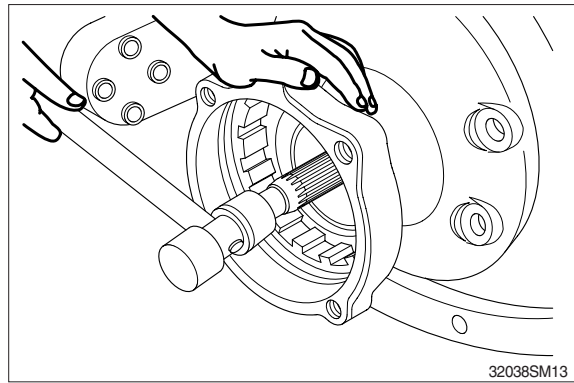

(14) Remove the shoe plate (103) from casing (101).

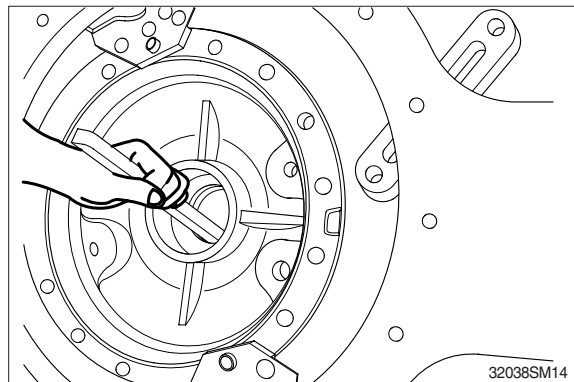

(15) Proceed with following job only when necessary.

- ① Remove the snap ring (143), spacer (113) from drive shaft (102) and remove the cone of roller bearing (144) by press.

※ Do not reuse bearings.

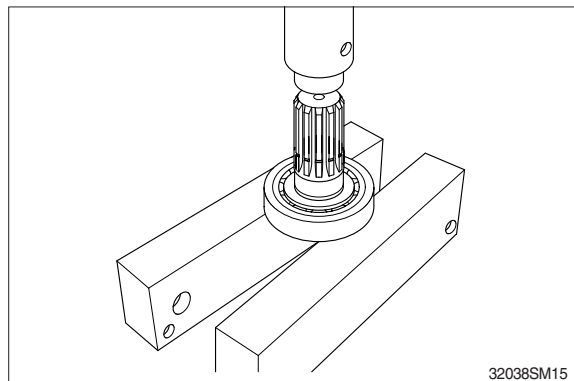
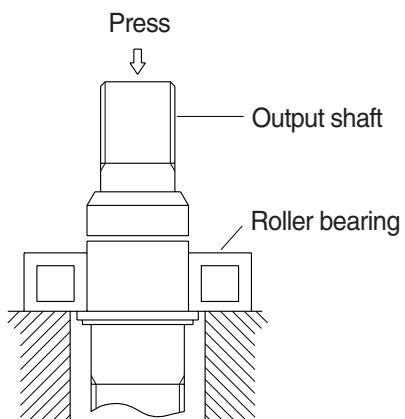

- ② Remove oil seal (130) from front cover (122).

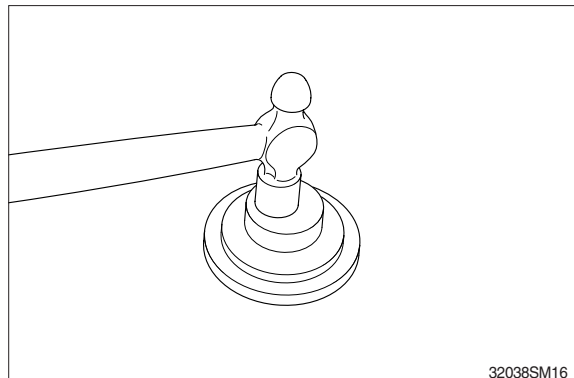

- ③ Remove the roller bearing (133) from the valve casing (101) by using slide hammer bearing puller.

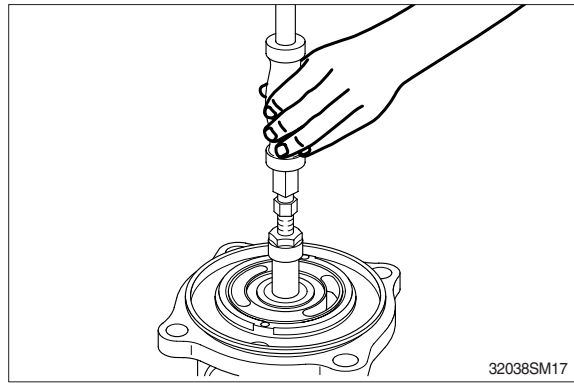

- ④ When disassembling the relief valve, release the plug (3). Remove the piston (7), spring seat (9), spring (8) and plunger (6) with the body (1) downwards.

※ Do not release the lock nut (15).

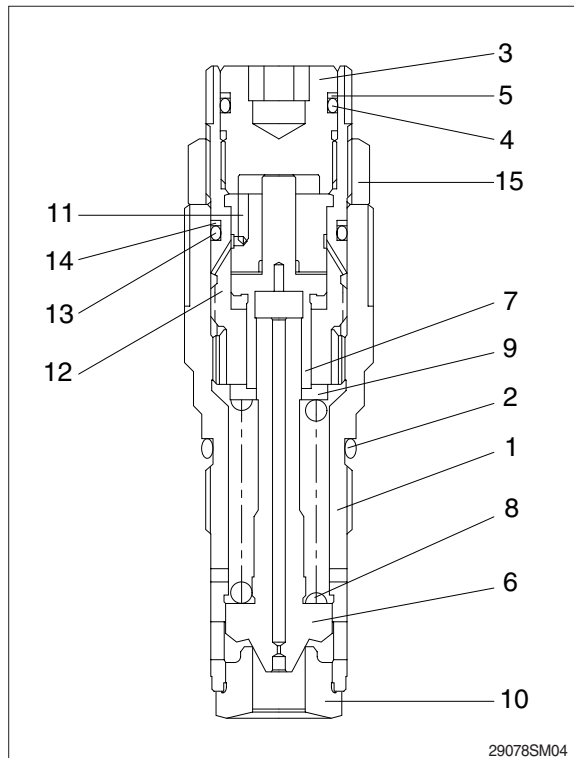

This completes disassembly.

### 3) ASSEMBLY

Do the reassembly in the reverse procedure of the disassembly.

- (1) Place the casing (101) on the workbench with the valve casing (115) downward.

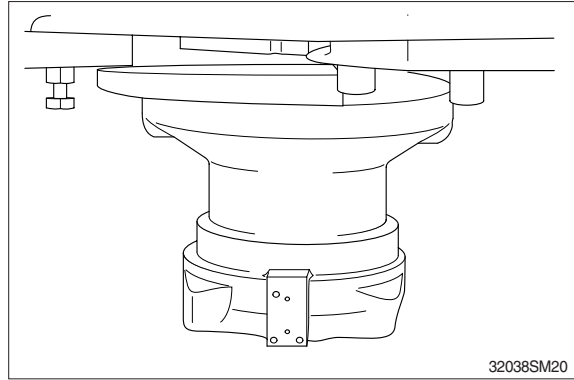

- (2) When reassembling the roller bearing, install the snap ring (143), and spacer (113) to the drive shaft (102). Insert the collar and cone of the roller bearing (144). Install the spacer (113) and stop ring (143). Install stop ring (144) to the output shaft (102) by heating the cone of the roller bearing (133).

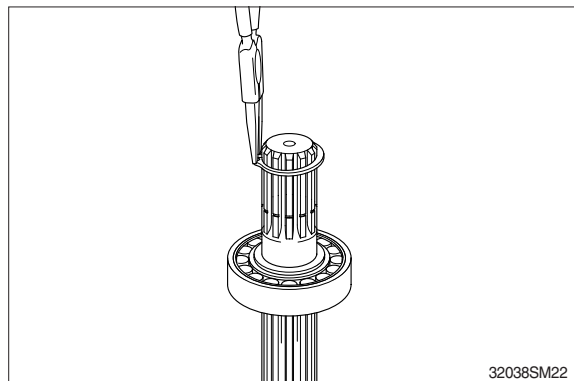
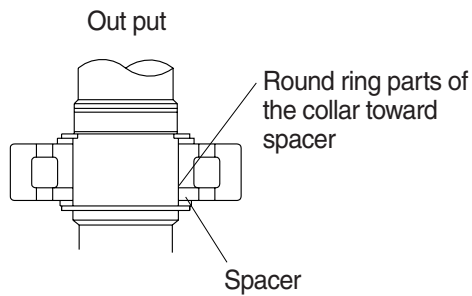
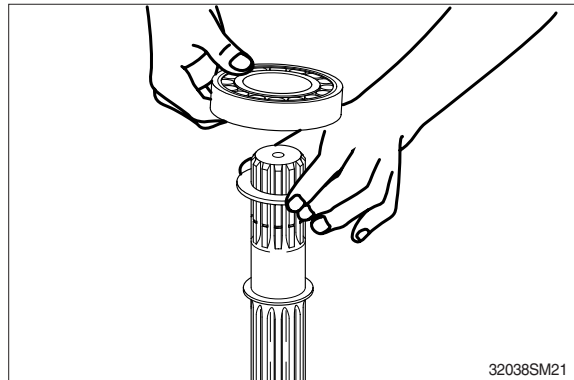

- (3) Insert the drive shaft (102) into the casing (101) with the end of output shaft upward and tap the outer race of roller bearing with the hammer.

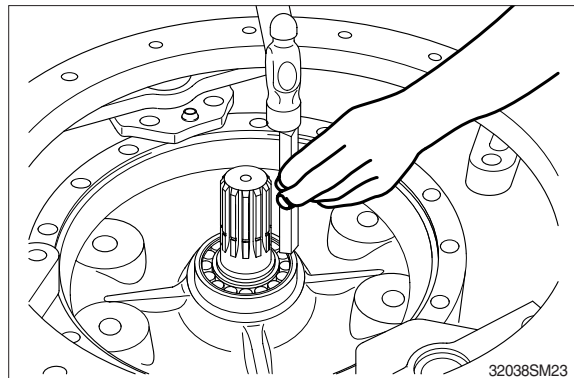



(4) Tack O-ring (145) to the casing (101).

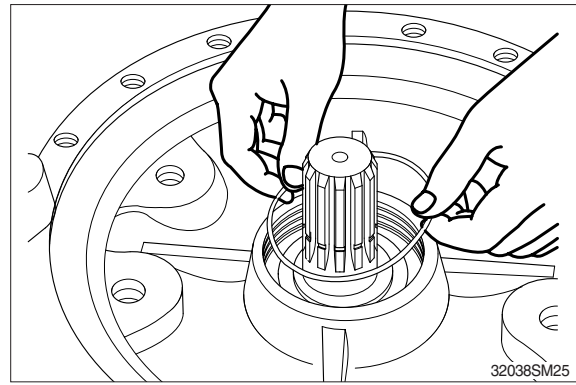

(5) Reassemble the front cover (122) to the casing (101).

※ Apply grease to the rib of oil seal to avoid damage to the rib.

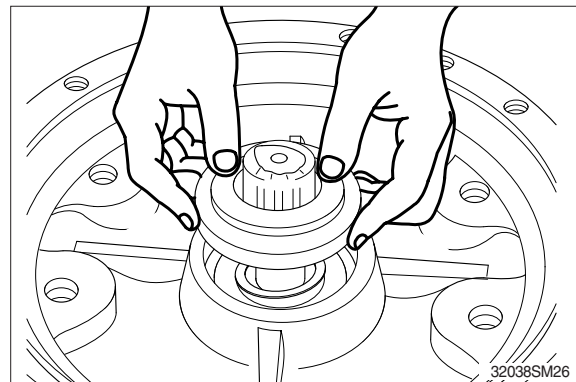

(6) Install the snap ring (129) to the casing (101).

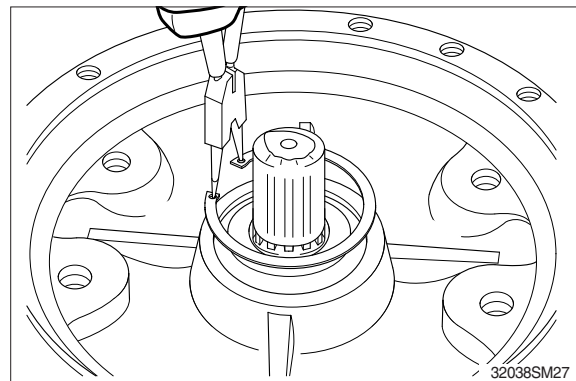

(7) Insert the shoe plate (103) with the casing (101) position horizontally.

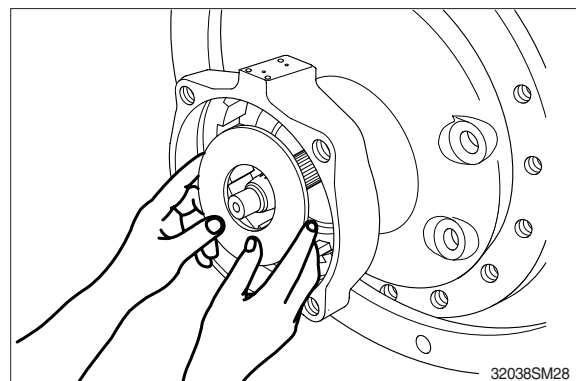

(8) Insert the spherical bush (106) into the cylinder (108). Place the retainer (105) assembled with spacer (121) onto the cylinder.

※ Insert two push rods in each hole.

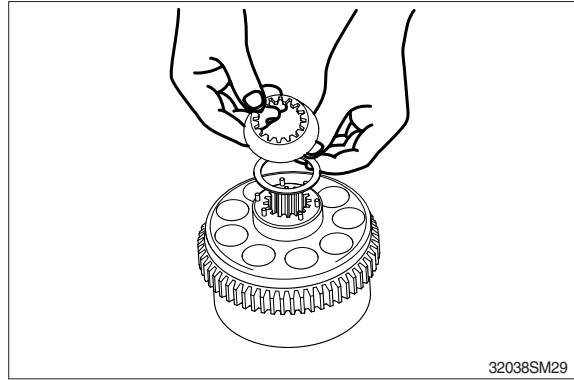

(9) Install the piston sub-assembly (120, 104) to the retainer (105).

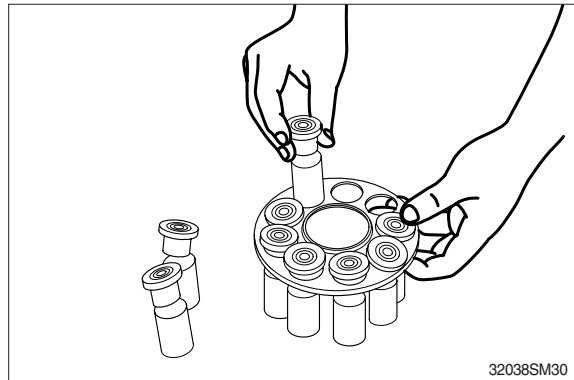

(10) Reassemble the piston assembly (120, 104) to the cylinder block (108).

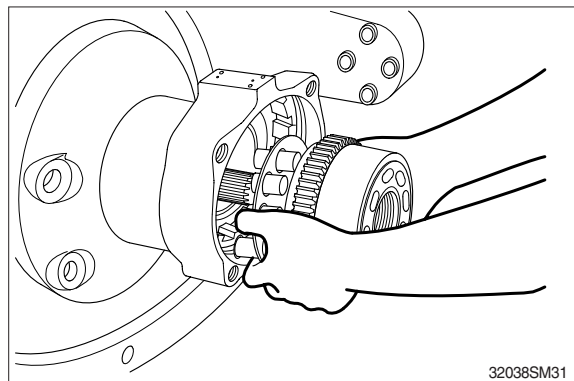

(11) Place the casing (101) under the front cover (122) and reassemble 3 sheets of separate plate (110) and then 2 sheets of friction plate (109) to the casing (101).

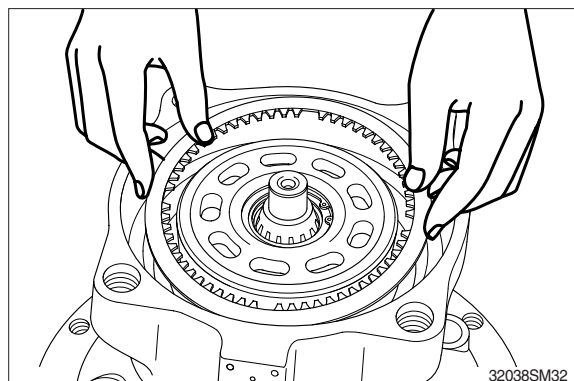

(12) Insert O-ring (141, 142) inside the casing (101).

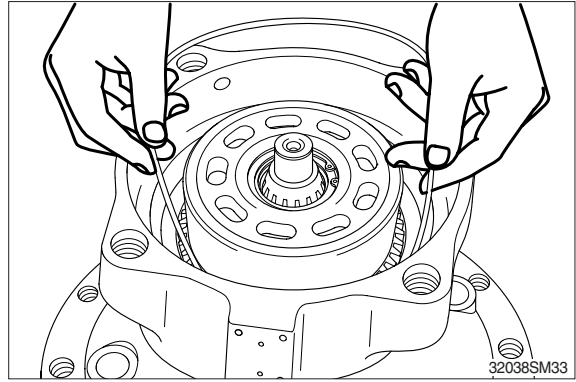

(13) Reassemble brake piston (119) to the casing (101).

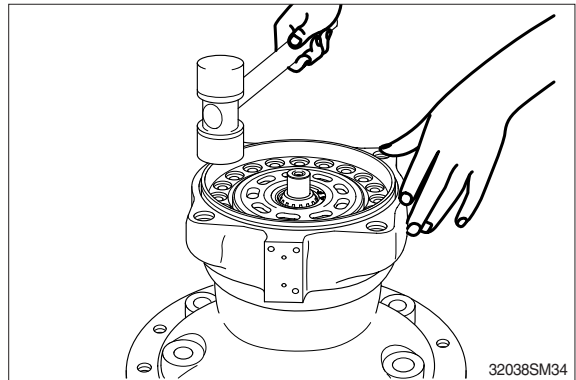

(14) Reassemble brake spring (118) to the brake piston (119).

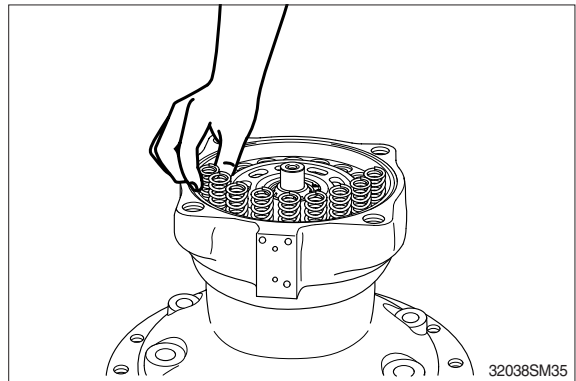

(15) When assembling the roller bearing (133), insert the roller bearing (444) into valve casing (115) by hammering.

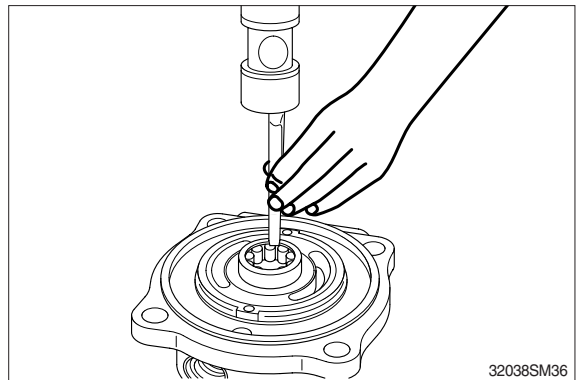

(16) Reassemble valve plate (112) to the valve casing (115) and reassemble O-ring (140).

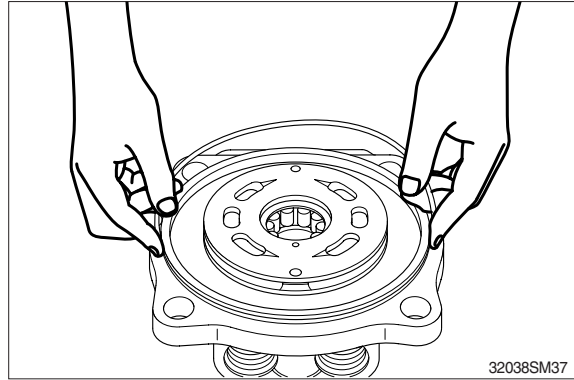

(17) Connect the valve casing (115) with the casing (101) and tighten the socket bolt (146).

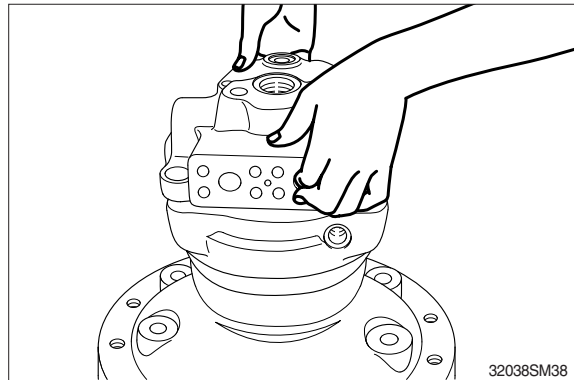

(18) Insert plunger (125) and spring (124) in the valve casing. Tighten plug (123) to the valve casing.

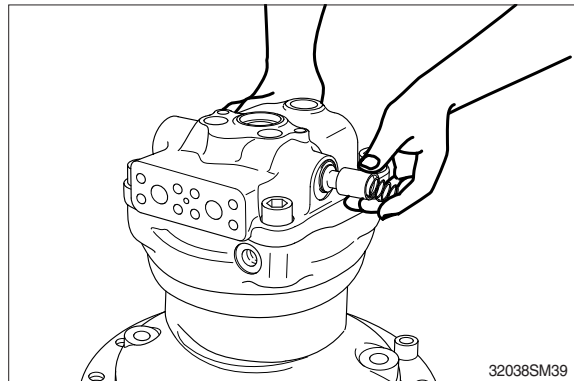

(19) Insert O-rings (127-1) to the relief valve (127) and reassemble them to valve casing (101).

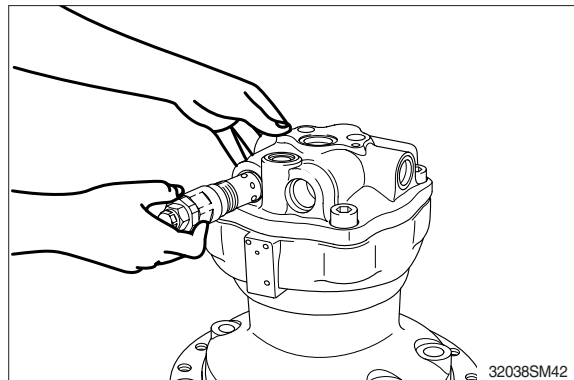

(20) Tighten the plug (114) to valve casing (115) to casing (301).

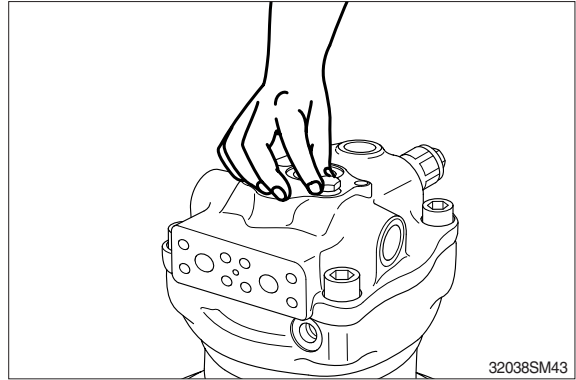

(21) Connect the valve casing (115) with the casing (101).

This completes assembly.

### 3. REMOVAL AND INSTALL OF REDUCTION GEAR

#### 1) REMOVAL

- (1) Remove the swing motor assembly.  
For details, see removal of swing motor assembly.
- (2) Sling reduction gear assembly(1) and remove mounting bolts(2).
- (3) Remove the reduction gear assembly.
  - Reduction gear device weight : 320 kg  
(705 lb)



#### 2) INSTALL

- (1) Carry out installation in the reverse order to removal.
  - Mounting bolt :  $84 \pm 8.0$  kgf · m  
( $608 \pm 58$  lbf · ft)

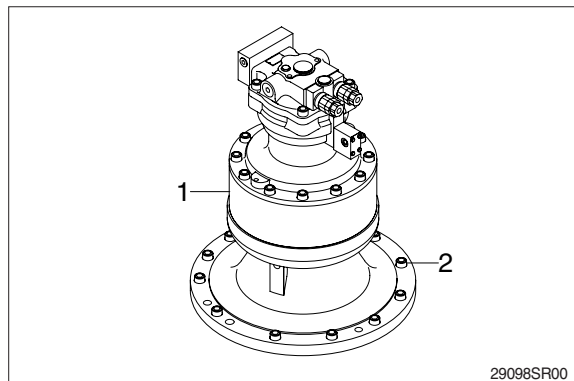

## 4. REDUCTION GEAR

### 1) STRUCTURE

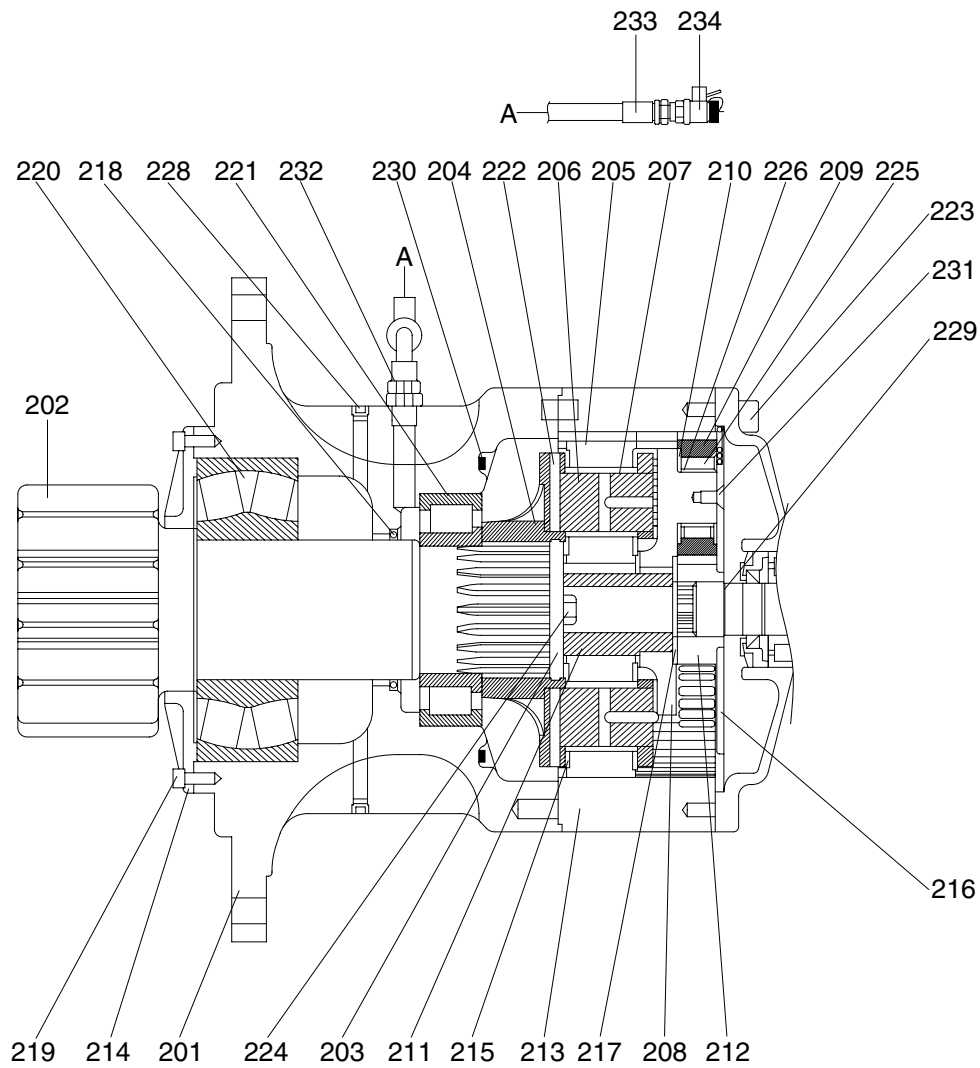

32092RG01

201	Casing	212	Sun gear 1	223	Socket bolt
202	Pinion shaft	213	Ring gear	224	Hex bolt
203	Preload plate	214	Cover	225	Needle bearing
204	Carrier 2	215	Thrust washer	226	Inner ring
205	Planet gear 2	216	Thrust plate	228	PT plug
206	Pin	217	Thrust washer	229	Snap ring
207	Bush	218	Oil seal	230	Magnet
208	Carrier 1	219	Socket bolt	231	Flat head screw
209	Planet gear 1	220	Spherical roller bearing	232	Connector (1/2 inch)
210	Thrust washer	221	Cylindrical roller bearing	233	Hose assembly
211	Sun gear 2	222	Spring pin	234	Drain valve assembly

## 2) DISASSEMBLY

- (1) Remove connector (232), hose assy (233) and drain valve (234).

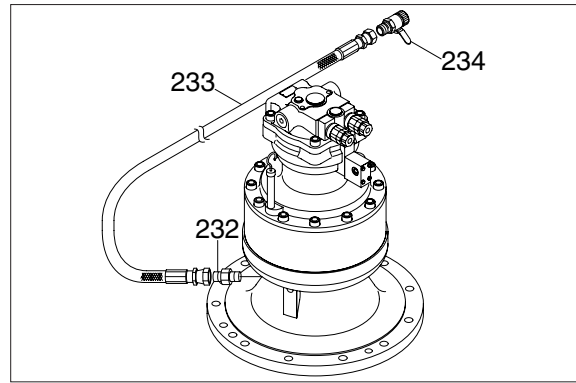

32098SR02

- (2) Remove gauge bar (236) and gauge pipe (237) from the swing motor casing.  
Pour the gear oil out of reduction gear into the clean bowl to check out the friction decrease.

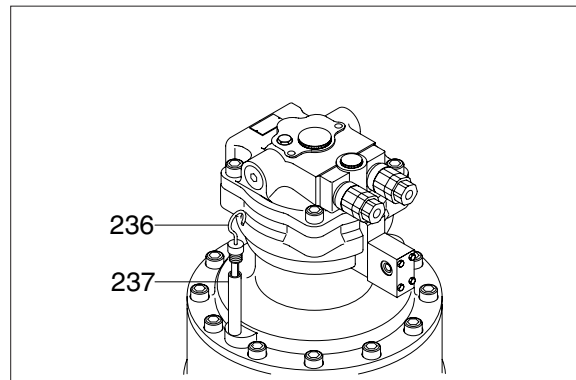

32098SR03

- (3) Loosen the socket bolt (223) to separate swing motor from reduction gear.

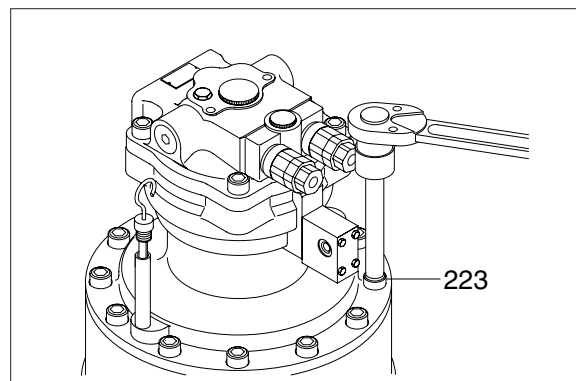

32098SR04

- (4) Full out No.1 sun gear (212).

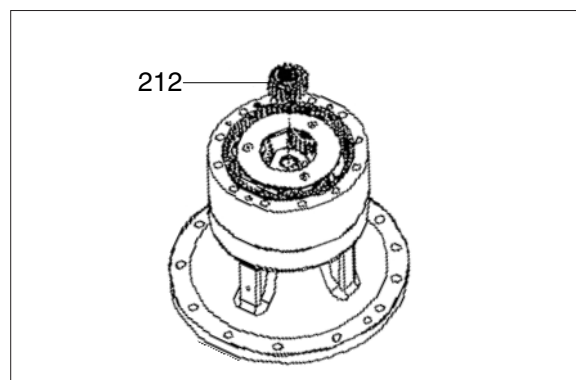

32098SR05



(5) Full out No.1 carrier subassembly.

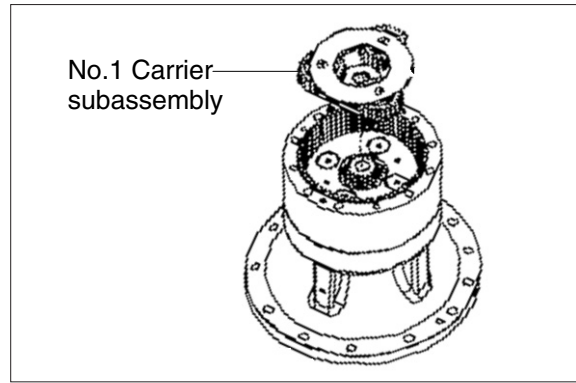

32098SR06

(6) Full out No.2 sun gear (211).  
※ Pay attention to ensure gear is not damaged during disassembling.

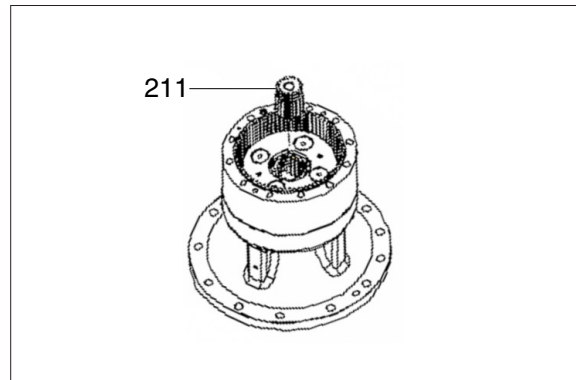

32098SR07

(7) Loosen the hexagon bolt (224).

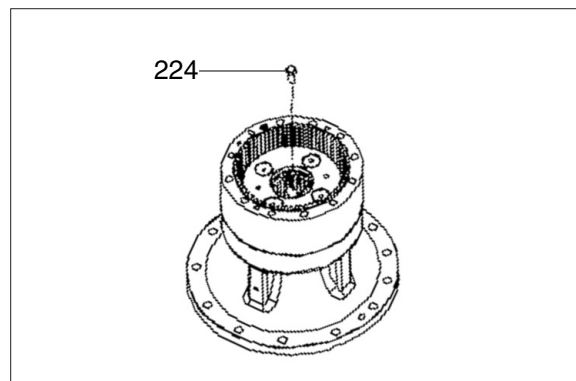

32098SR08

(8) Full out No.2 carrier subassembly.

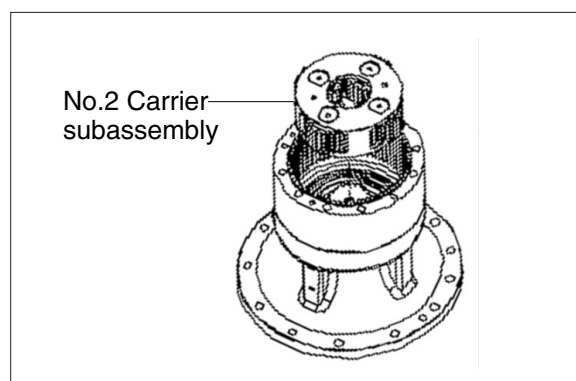

32098SR09A

(9) Loosen the hexagon socket bolt (227).

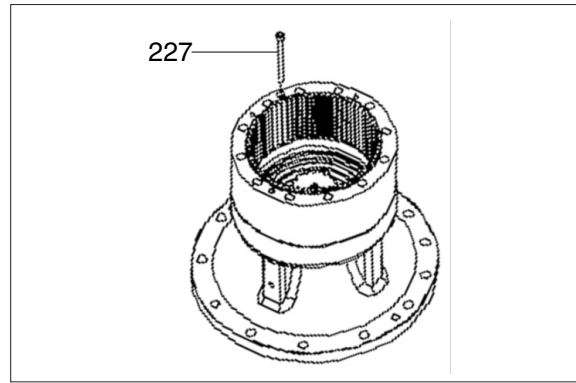

32098SR10

(10) Tighten two M10 eye bolts to ring gear (213) and lift up and remove ring gear (213).

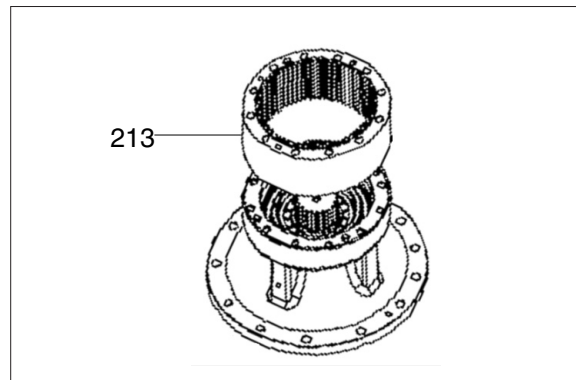

32098SR11

(11) Full out pin (235).

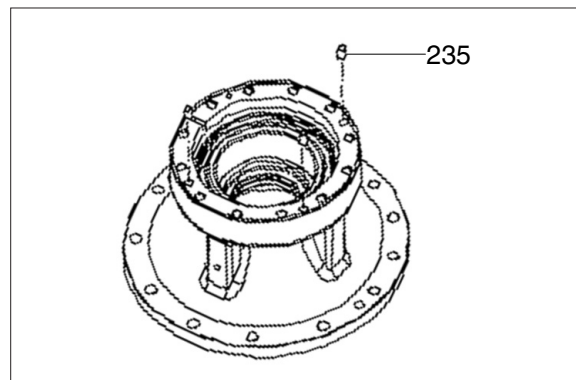

32098SR12

(12) Full out magnet (230).

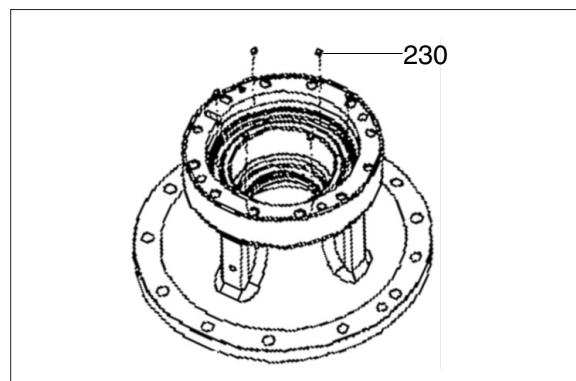

32098SR13

(13) Loosen the hexagon socket bolt (219).

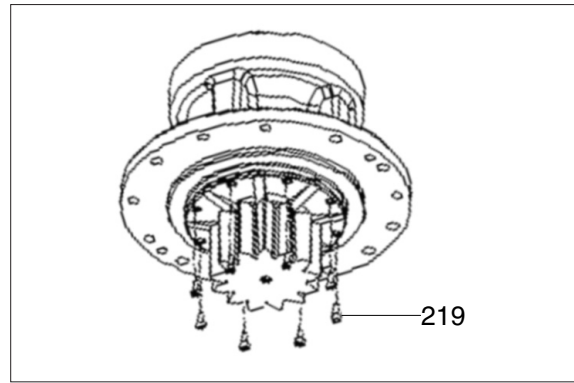

32098SR14

(14) Remove the shaft sub assembly with pinion shaft (202).

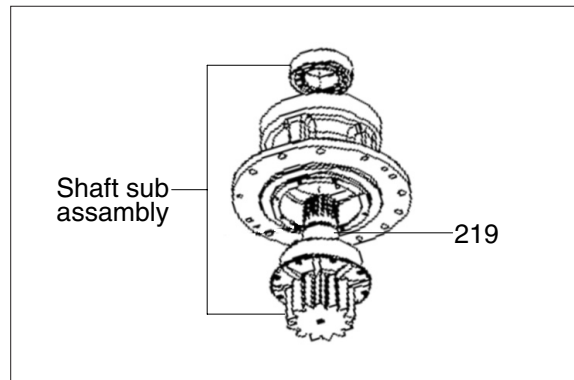

32098SR15

(15) Press drive shaft by using jig to remove spherical roller bearing (220) and cover (214).

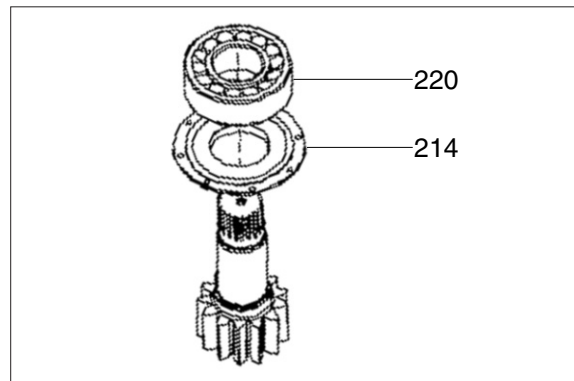

32098SR16

(16) Full out oil gear (218).

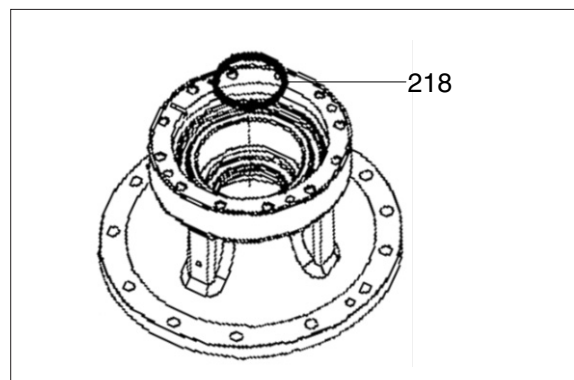

32098SR17

## 2) ASSEMBLY

- (1) Place the casing (201) on the reversing machine having the flange side of the casedown.

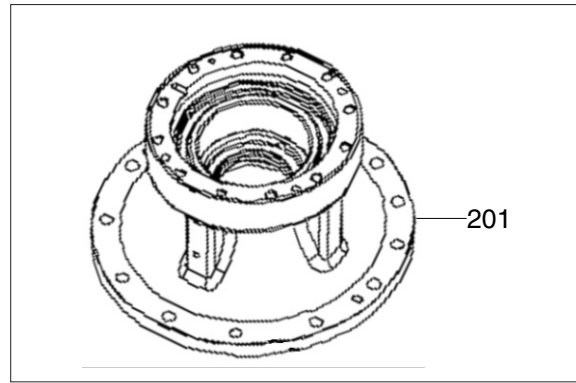

32098SR18

- (2) Press the insert oil seal (218) by using pressure jig after spreading grease oil around the out side ring of the seal.  
Coat grease oil slightly on the lip surface to prevent any scratch when installing.  
※ Be sure to check by eye that the oil seal is seated completely after being installed.

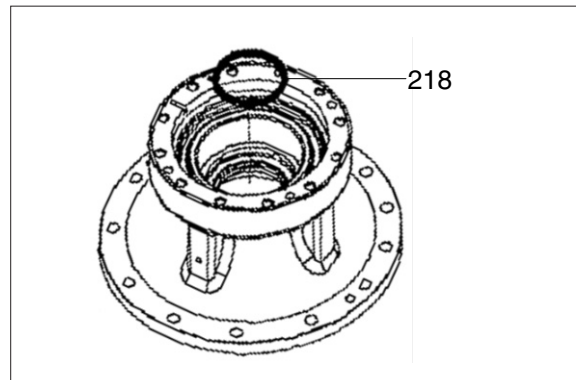

32098SR17

- (3) Insert cover (214) to pinion shaft (202) and insert spherical roller bearing (220) by using a pressing jig.

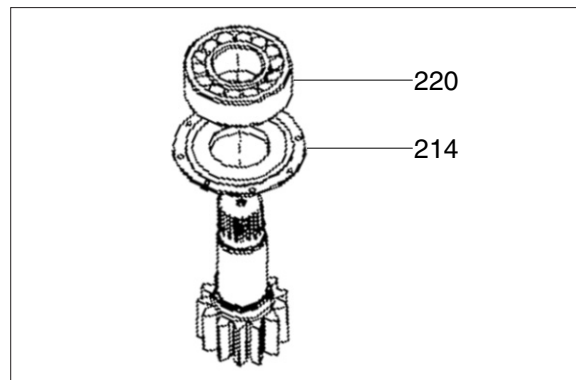

32098SR16

- (4) Install pinion shaft (202) sub assembly into casing by using a pressing jig.

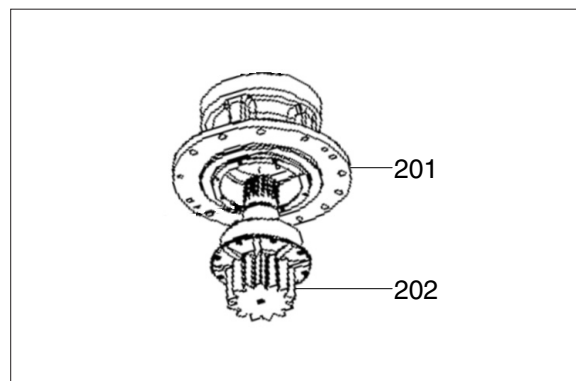

32098SR19

- (5) Install roller bearing (221) into casing by using a pressing jig.

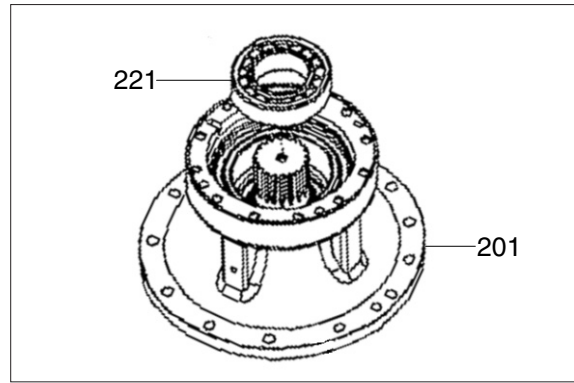

32098SR20

- (6) Insert magnet (230).

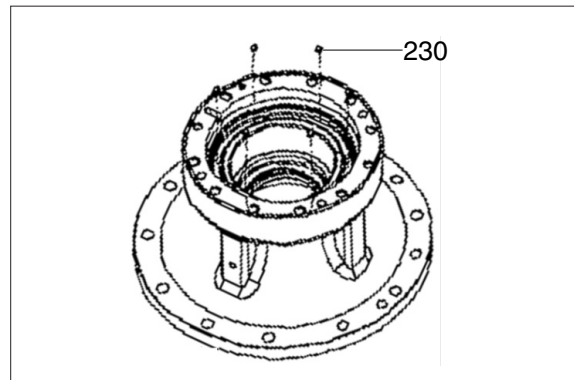

32098SR13

- (7) Insert pin (235).

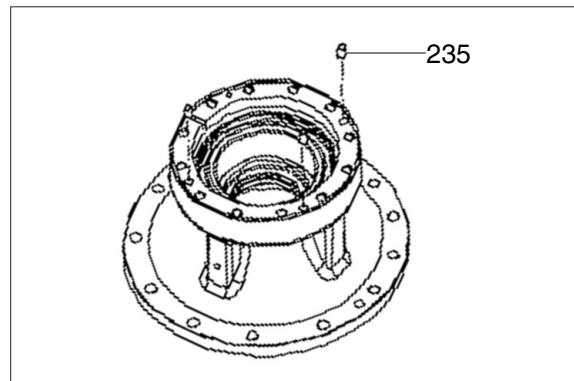

32098SR12

- (8) Place ring gear on the case by matching it with pin hole.

※ Be sure to check the hole location of oil gage before inserting.

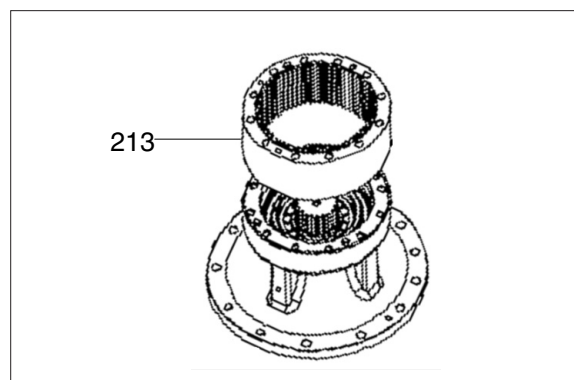

32098SR11

(9) Assemble ring gear with case by screwing socket bolt (227).

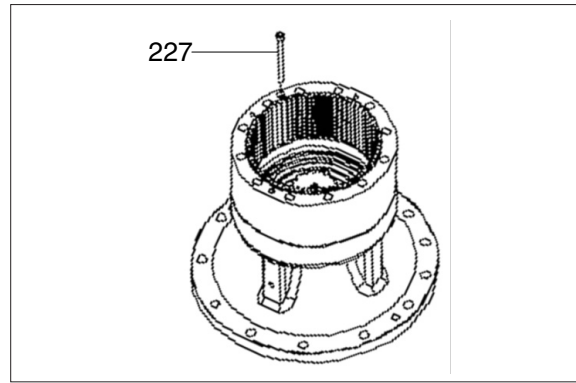

32098SR10

(10) Mount No.2 carrier subassembly in the casing.

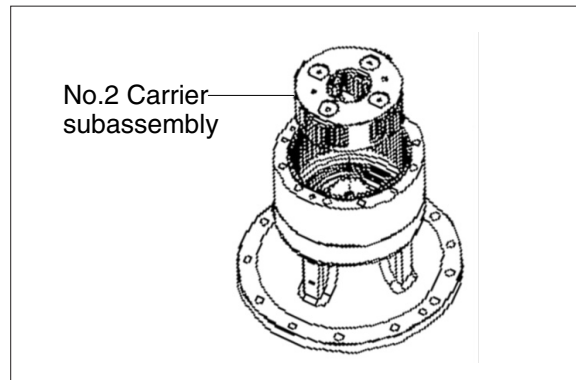

32098SR09A

(11) Tighten hexagon bolt (224).

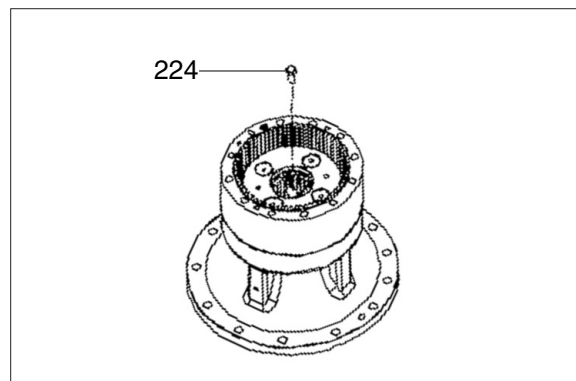

32098SR08

(12) Install No.2 sun gear (211).

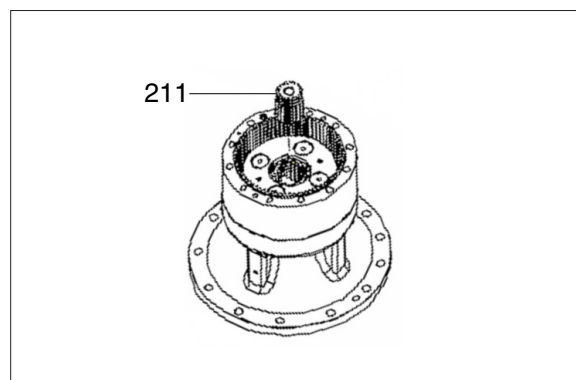

32098SR07

(13) Mount No.1 carrier subassembly.

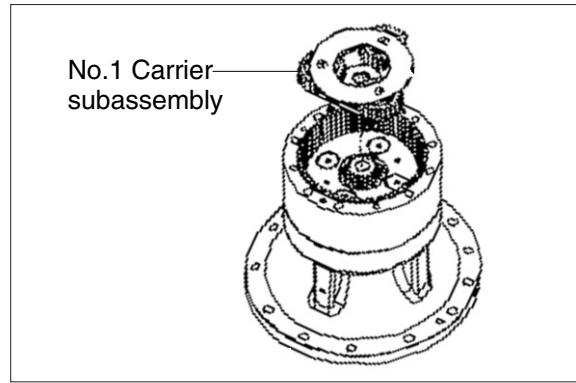

32098SR06

(14) Install No.1 sun gear (212).

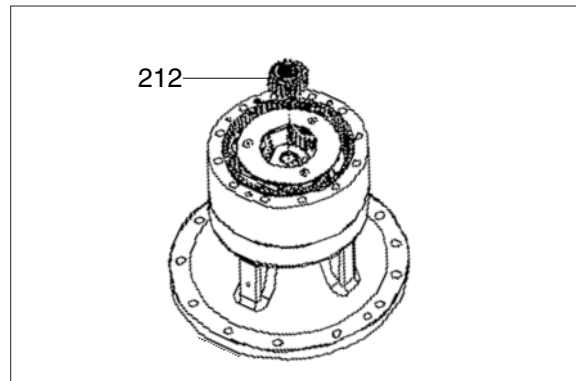

32098SR05

(15) Tighten socket bolt (223) around the swing motor assembly.

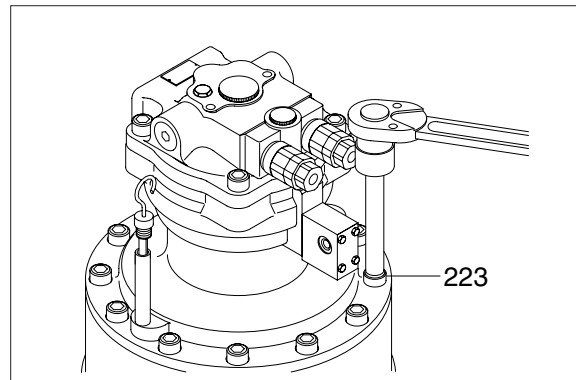

32098SR04

(16) Assemble gauge bar (236) and gauge pipe (237).

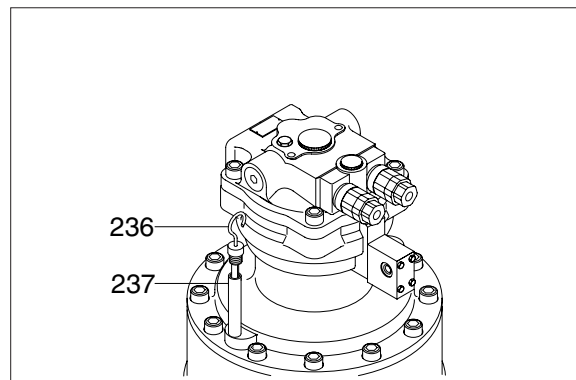

32098SR03

(17) Assemble connector (232).  
Hose assy (233) and drain valve (234).

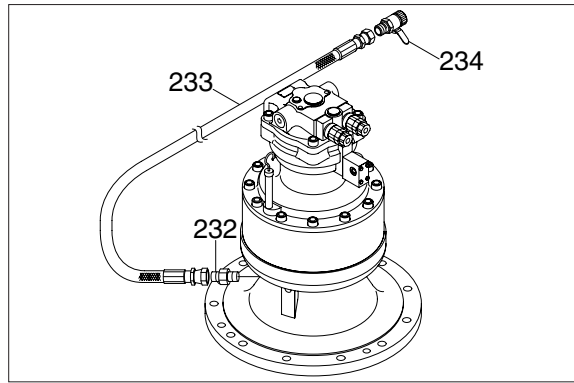

32098SR02