

GROUP 12 ENGINE CONTROL SYSTEM

1. MCU (Machine Control Unit)

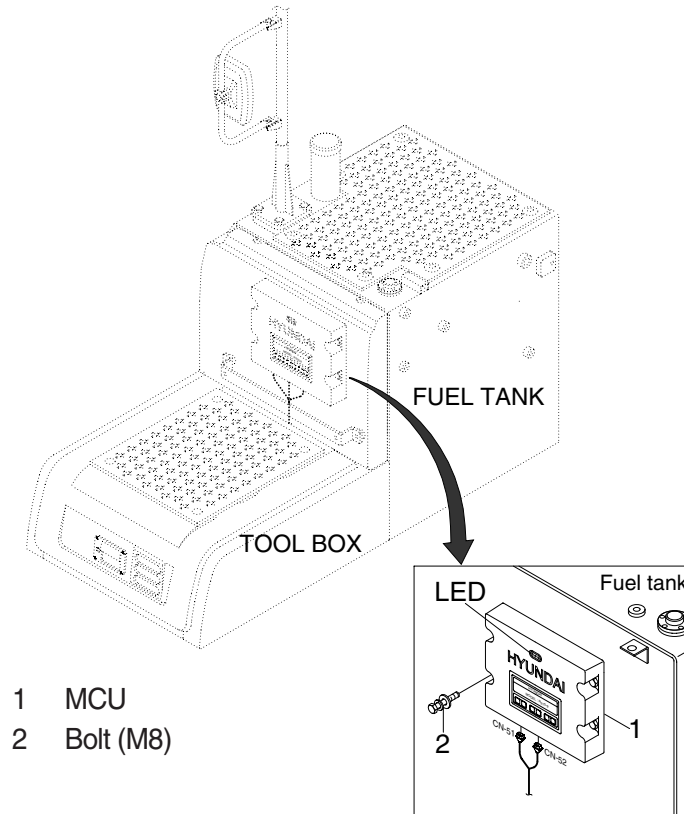

3009SH5MS13

2. MCU ASSEMBLY

- 1) To match the pump absorption torque with the engine torque, MCU varies EPPR valve output pressure, which control pump discharge amount whenever feedbacked engine speed drops under the reference rpm of each mode set.
- 2) Three LED lamps on the MCU display as below.

LED lamp	Trouble	Service
G is turned ON	Normal	-
G and R are turned ON	Trouble on MCU	- Change the MCU
G and Y are turned ON	Trouble on serial communication line	- Check if serial communication lines between controller and cluster are disconnected
Three LED are turned OFF	Trouble on MCU power	- Check if the input power wire (24 V, GND) of controller is disconnected Check the fuse

G : green, R : red, Y : yellow

3. EXCHANGE METHOD OF THE ROM IN THE CLUSTER (TYPE 2)

- 1) Disassemble screws (2) and wiper motor cover (1).
- 2) Disassemble hexgon socket bolts (3) and cluster (4).

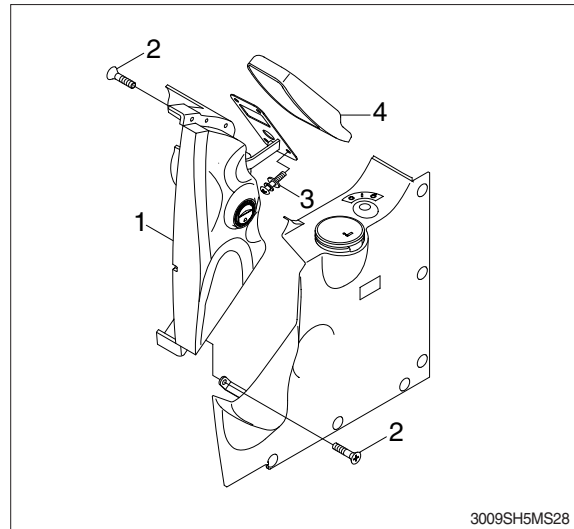

- 4) Loosen the screws (6EA) located back of the cluster.
- 5) Then you can open the upper case of the cluster easily.

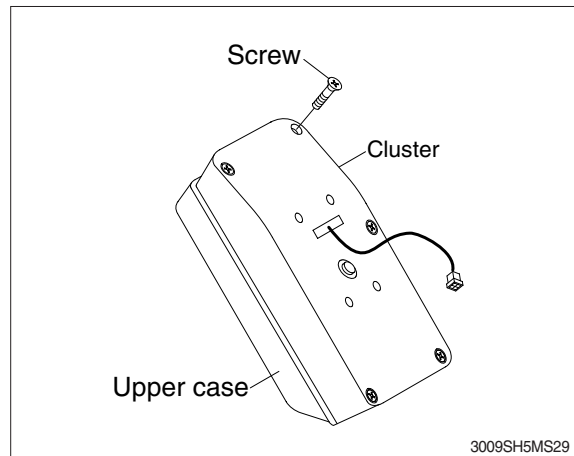

- 6) Install the new ROM. (Be careful of direction and assemble the cluster in the reverse order to removal).

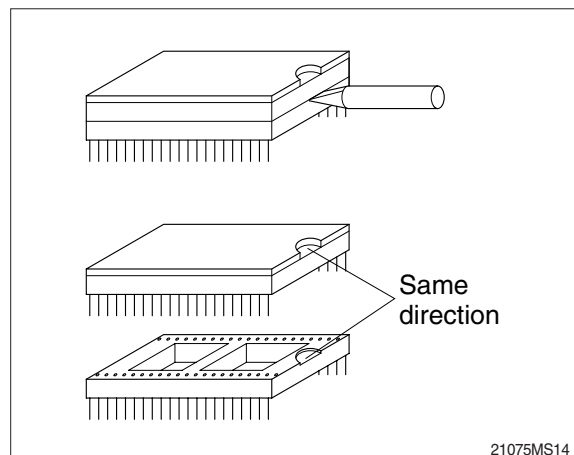

4. ENGINE SPEED SENSOR

1) DETECT ACTUAL ENGINE RPM AND SEND SIGNAL TO TACHOMETER

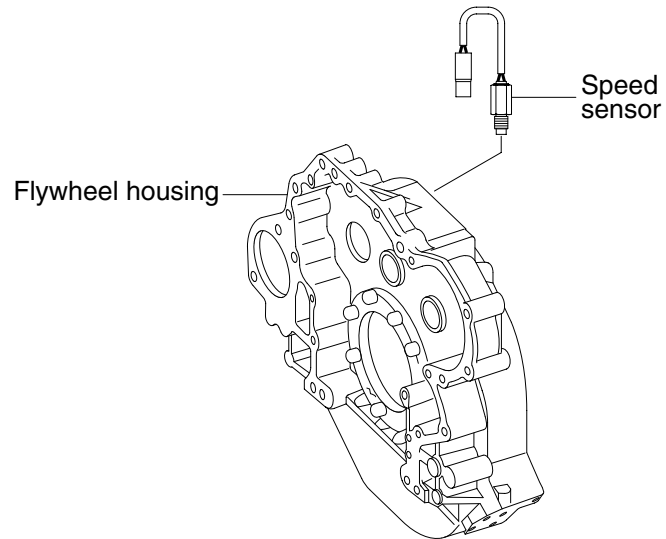

21H75MS10

2) INSTALLATION

- (1) Clean contacting point of sensor.
- (2) Screw speed sensor into flywheel housing.

3) INSPECTION

- (1) Check resistance
 - SPEC : $2.3 \pm 0.2 \Omega$
- (2) Tightening torque
 - $3.75 \pm 0.75 \text{ kgf} \cdot \text{m}$