

GROUP 3 TRACK AND WORK EQUIPMENT

1. TRACK

1) TRACK ROLLER

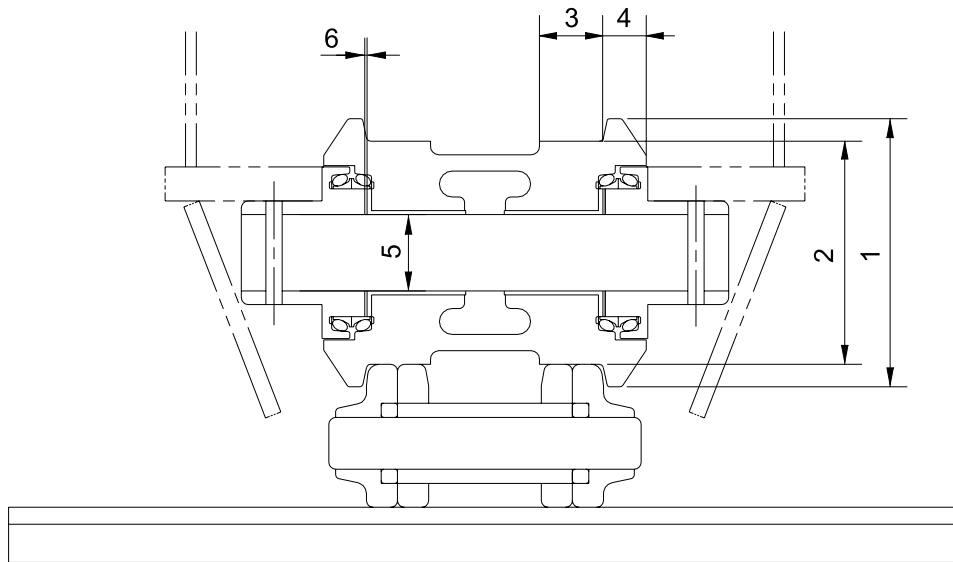

32077MS01

Unit : mm

No.	Check item	Criteria			Remedy
		Standard size		Repair limit	
1	Outside diameter of flange	Standard size		Repair limit	Rebuild or replace
		ø 216		-	
2	Outside diameter of tread	ø 180		ø 168	
3	Width of tread	50		56	
4	Width of flange	57		-	
5	Clearance between shaft and bushing	Standard size & tolerance		Standard clearance	Clearance limit
		Shaft	Hole		
		ø 75 $\begin{matrix} 0 \\ -0.055 \end{matrix}$	ø 75.35 $\begin{matrix} +0.05 \\ 0 \end{matrix}$	0.35 to 0.455	2.0
6	Side clearance of roller (both side)	Standard clearance		Clearance limit	
		0.16~1.24		2.0	

2) CARRIER ROLLER

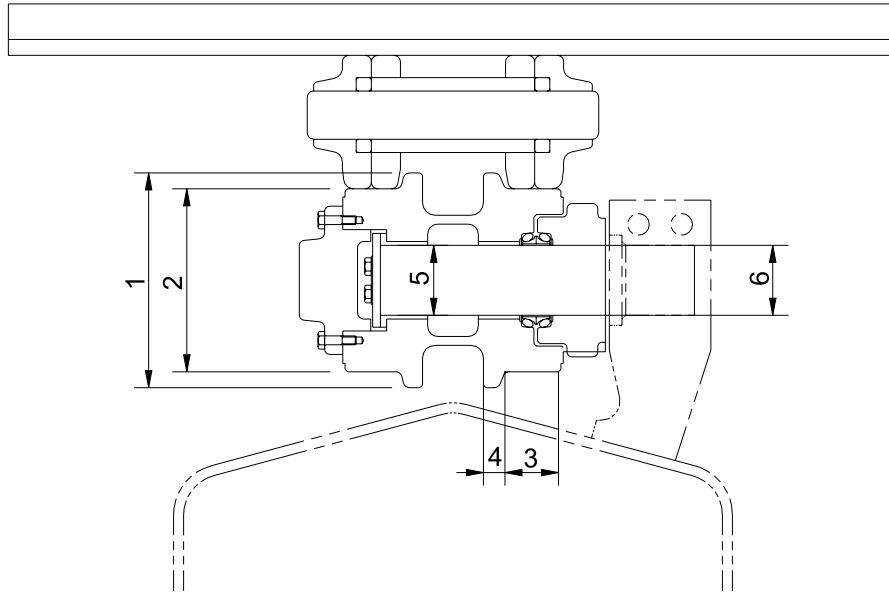

32077MS02

Unit : mm

No.	Check item	Criteria				Remedy
		Standard size		Repair limit		
1	Outside diameter of flange	ø 200		-		Rebuild or replace
2	Outside diameter of tread	ø 168		ø 158		
3	Width of tread	54		59		
4	Width of flange	19		-		
5	Clearance between shaft and bushing	Standard size & tolerance		Standard clearance	Clearance limit	Replace bushing
		Shaft	Hole			
6	Clearance between shaft and support	ø 58 $\begin{matrix} 0 \\ -0.1 \end{matrix}$	ø 58 $\begin{matrix} +0.5 \\ +0.3 \end{matrix}$	0.3 to 0.6	1.2	Replace

3) IDLER

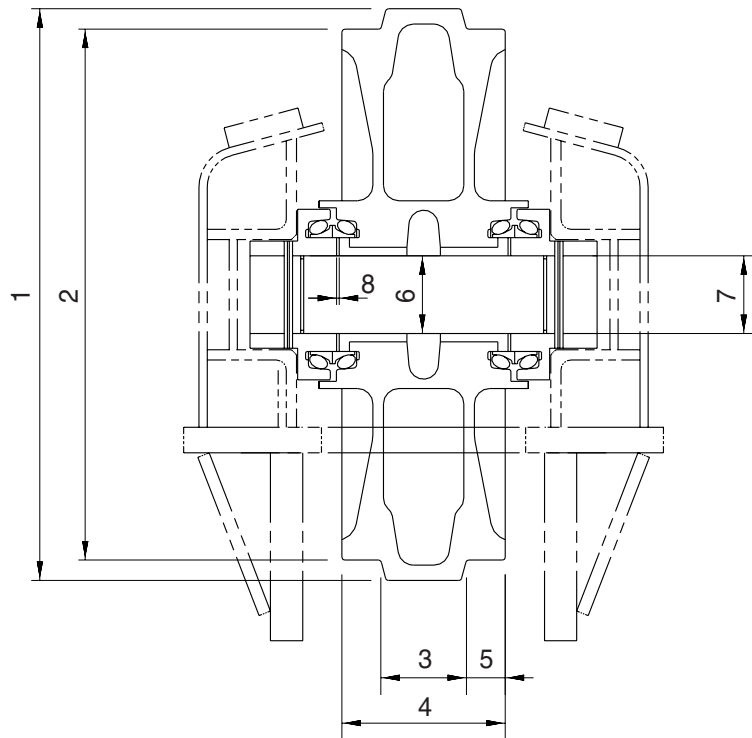

21073MS03

Unit : mm

No.	Check item	Criteria		Remedy		
		Standard size	Repair limit			
1	Outside diameter of protrusion	$\phi 646$	$\phi 636$	Rebuild or replace		
2	Outside diameter of tread	$\phi 594$	$\phi 588$			
3	Width of protrusion	102	92			
4	Total width	203	-			
5	Width of tread	50.5	55.5			
6	Clearance between shaft and bushing	Standard size & tolerance		Standard clearance	Clearance limit	Replace bushing
		Shaft	Hole			
	$\phi 90 \begin{matrix} 0 \\ -0.035 \end{matrix}$	$\phi 90.35 \begin{matrix} +0.05 \\ 0 \end{matrix}$				
7	Clearance between shaft and support	$\phi 90 \begin{matrix} 0 \\ -0.035 \end{matrix}$	$\phi 90 \begin{matrix} +0.09 \\ +0.036 \end{matrix}$	0.036 to 0.125	1.2	Replace
8	Side clearance of idler (both side)	Standard clearance 0.4 to 1.2		Clearance limit 2.0		Replace

4) TRACK

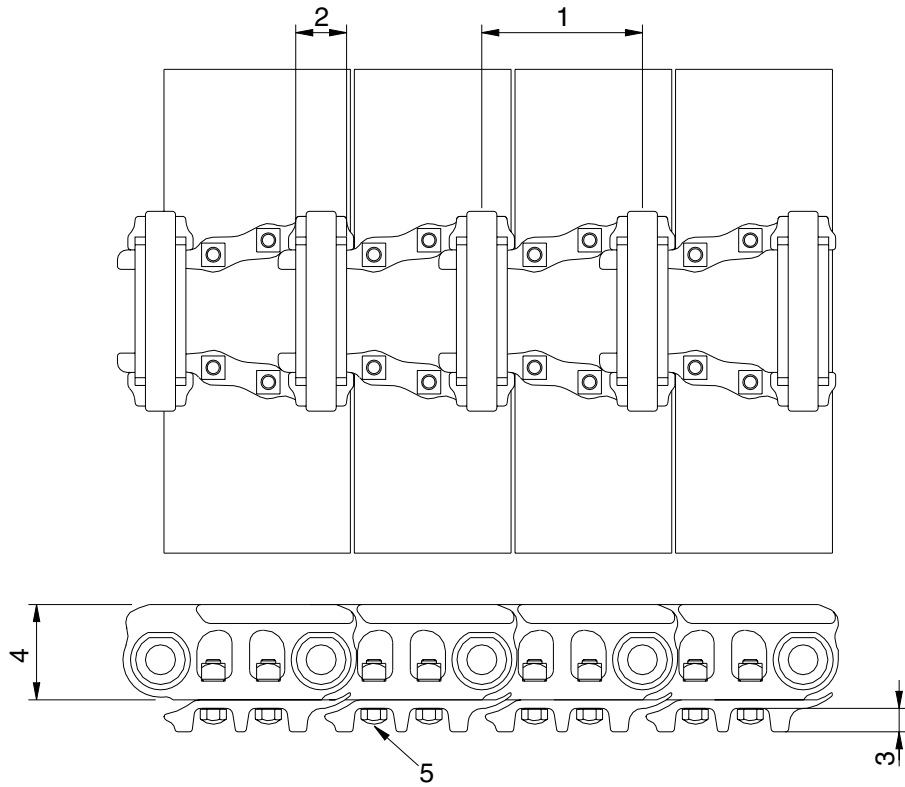

32077MS04

Unit : mm

No.	Check item	Criteria		Remedy
		Standard size	Repair limit	
1	Link pitch	216	223	Turn or replace
2	Outside diameter of bushing	∅ 66.5	∅ 58.5	
3	Height of grouser	30	21	Rebuild or replace
4	Height of link	116	104	
5	Tightening torque	Initial tightening torque : 115 ± 5 kgf · m		Retighten

5) TRACK FRAME AND RECOIL SPRING

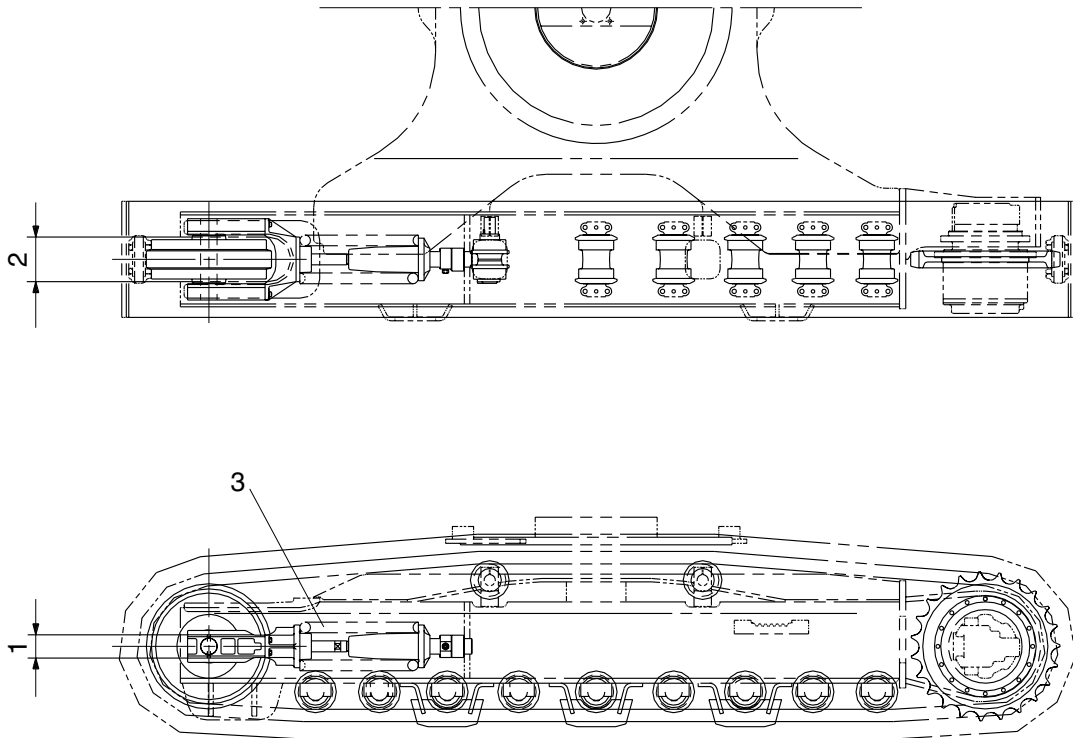

21073MS05

Unit : mm

No.	Check item	Criteria				Remedy	
			Standard size	Tolerance	Repair limit		
1	Vertical width of idler guide	Track frame	132	+2 0	138	Rebuild or replace	
		Idler support	130	0 -1.5	124		
2	Horizontal width of idler guide	Track frame	292	+2 0	298		
		Idler support	290	-	286		
3	Recoil spring	Standard size		Repair limit		Replace	
		Free length	Installation length	Installation load	Free length		Installation load
		∅ 253 × 710	580	19012 kg	-		15210 kg

2. WORK EQUIPMENT

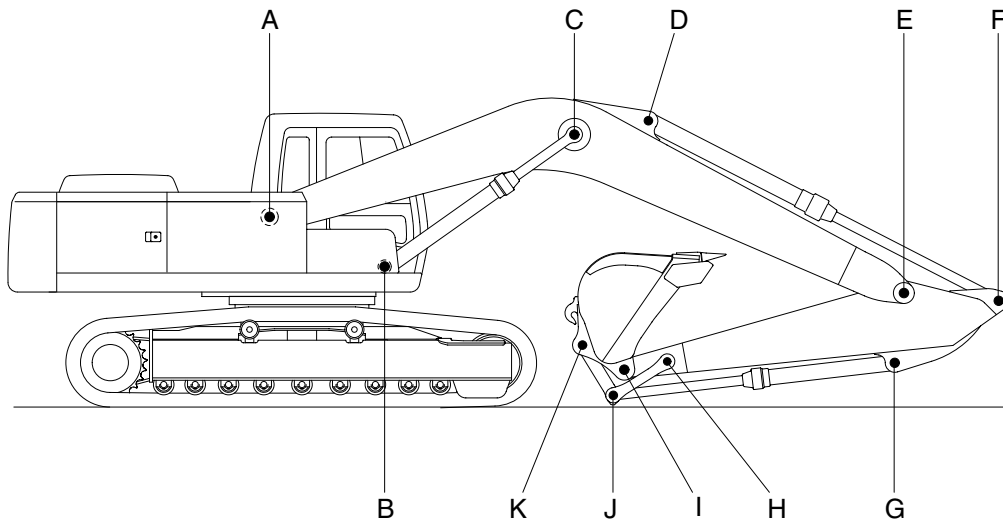

21077MS20

Unit : mm

Mark	Measuring point (Pin and Bushing)	Normal value	Pin		Bushing		Remedy & Remark
			Recomm. service limit	Limit of use	Recomm. service limit	Limit of use	
A	Boom Rear	110	109	108.5	110.5	111	Replace
B	Boom Cylinder Head	100	99	98.5	100.5	101	
C	Boom Cylinder Rod	100	99	98.5	100.5	101	
D	Arm Cylinder Head	100	99	98.5	100.5	101	
E	Boom Front	100	99	98.5	100.5	101	
F	Arm Cylinder Rod	100	99	98.5	100.5	101	
G	Bucket Cylinder Head	90	89	88.5	90.5	91	
H	Arm Link	90	89	88.5	90.5	91	
I	Bucket and Arm Link	100	99	98.5	100.5	101	
J	Bucket Cylinder Rod	90	89	88.5	90.5	91	
K	Bucket Link	100	99	98.5	100.5	101	