

# GROUP 2 SPECIFICATIONS

## 1. MAJOR COMPONENT

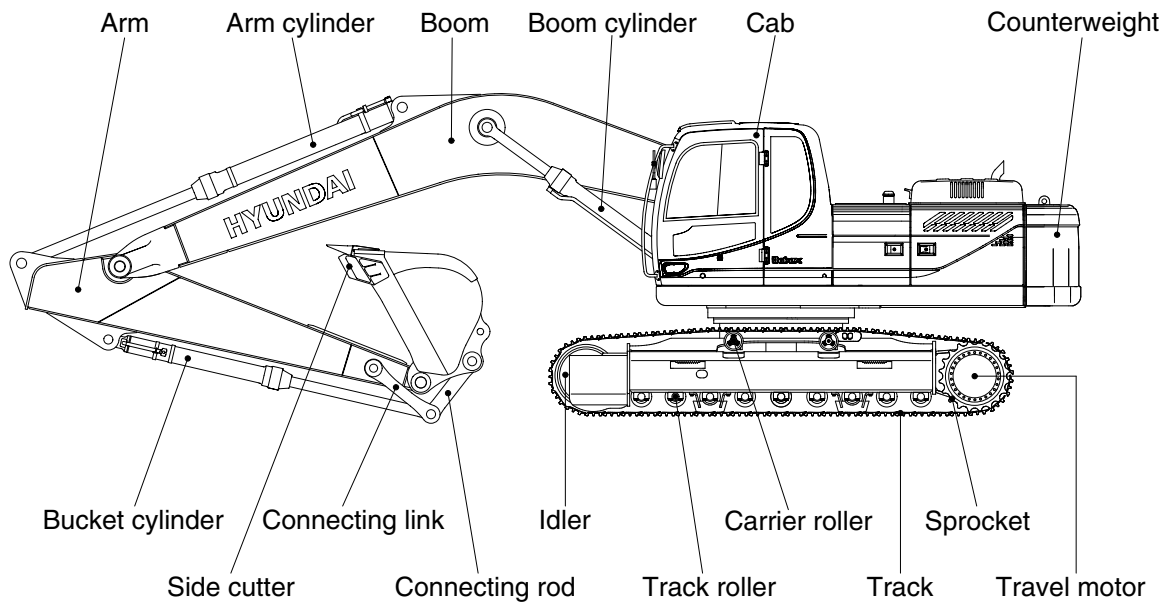
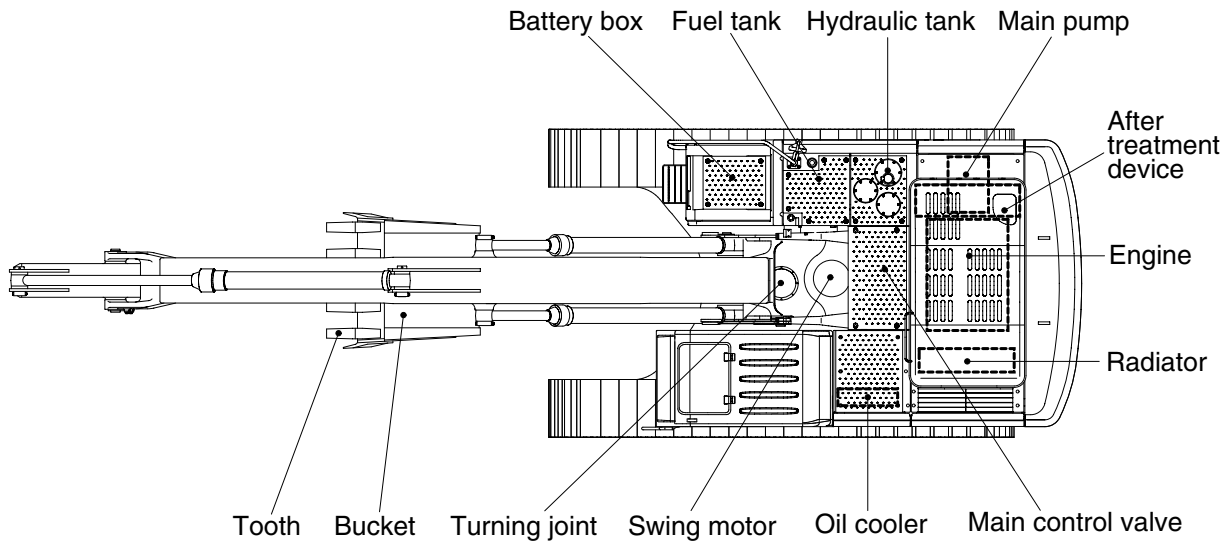

3309A2SP01

## 2. SPECIFICATIONS

### 1) R330LC-9A

- 6.45 m (21' 2") BOOM and 3.20 m (10' 6") ARM

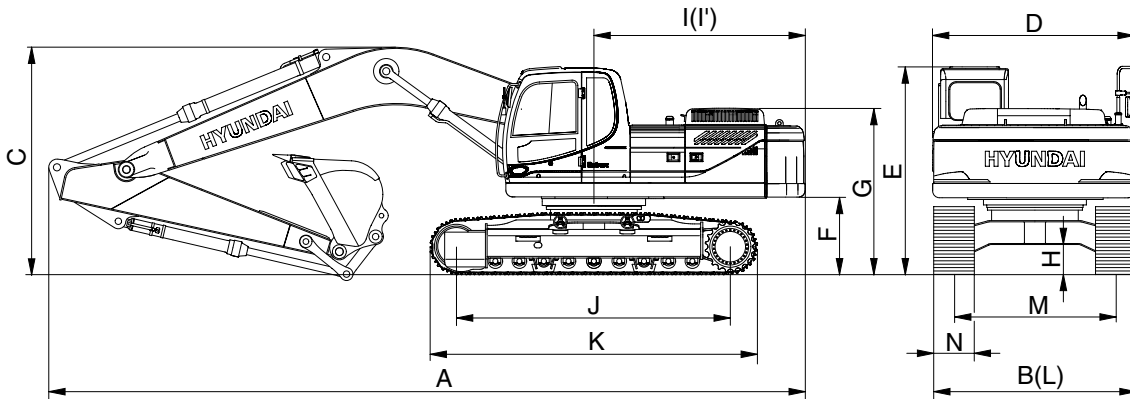

3309A2SP02

Description		Unit	Specification
Operating weight		kg (lb)	33000 (72750)
Bucket capacity (SAE heaped), standard		m <sup>3</sup> (yd <sup>3</sup> )	1.44 (1.88)
Overall length	A	mm (ft-in)	11220 (36' 10")
Overall width, with 600 mm shoe	B		3280 (10' 9")
Overall height	C		3380 (11' 1")
Superstructure width	D		2980 ( 9' 9")
Overall height of cab	E		3090 (10' 2")
Ground clearance of counterweight	F		1200 ( 3' 11")
Engine cover height	G		2755 ( 9' 0")
Minimum ground clearance	H		500 ( 1' 8")
Rear-end distance	I		3504 (11' 6")
Rear-end swing radius	I'		3560 (11' 8")
Distance between tumblers	J		4030 (13' 3")
Undercarriage length	K		4940 (16' 2")
Undercarriage width	L		3280 (10' 9")
Track gauge	M		2680 ( 8' 10")
Track shoe width, standard	N		600 (24")
Travel speed (low/high)		km/hr (mph)	3.3/5.5 (2.1/3.4)
Swing speed		rpm	9.2
Gradeability		Degree (%)	35 (70)
Ground pressure (600 mm shoe)		kgf/cm <sup>2</sup> (psi)	0.63 (8.96)
Max traction force		kg (lb)	29500 (65040)

## 2) R330NLC-9A

· 6.45 m (21' 2") BOOM and 3.20 m (10' 6") ARM

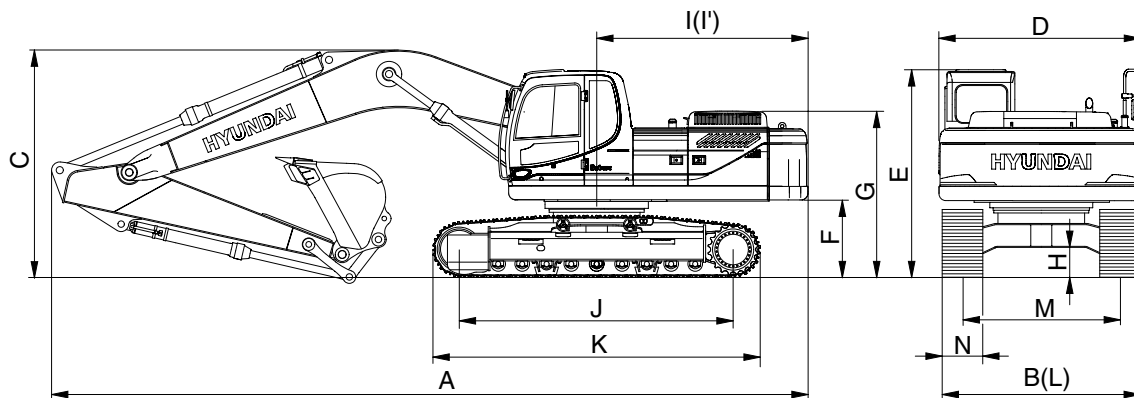

3309A2SP03

Description		Unit	Specification
Operating weight		kg (lb)	32800 (72310)
Bucket capacity (SAE heaped), standard		m <sup>3</sup> (yd <sup>3</sup> )	1.44 (1.88)
Overall length	A	mm (ft-in)	11220 (36' 10")
Overall width, with 600 mm shoe	B		2990 ( 9' 10")
Overall height	C		3380 (11' 1")
Superstructure width	D		2980 ( 9' 9")
Overall height of cab	E		3090 (10' 2")
Ground clearance of counterweight	F		1200 ( 3' 11")
Engine cover height	G		2755 ( 9' 0")
Minimum ground clearance	H		500 ( 1' 8")
Rear-end distance	I		3504 (11' 6")
Rear-end swing radius	I'		3560 (11' 8")
Distance between tumblers	J		4030 (13' 3")
Undercarriage length	K		4940 (16' 2")
Undercarriage width	L		2990 ( 9' 10")
Track gauge	M		2390 ( 7' 10")
Track shoe width, standard	N		600 (24")
Travel speed (low/high)			km/hr (mph)
Swing speed		rpm	9.2
Gradeability		Degree (%)	35 (70)
Ground pressure (600 mm shoe)		kgf/cm <sup>2</sup> (psi)	0.63 (8.96)
Max traction force		kg (lb)	29500 (65040)

### 3) R330LC-9A HIGH WALKER

· 6.45 m (21' 2") BOOM and 3.20 m (10' 6") ARM

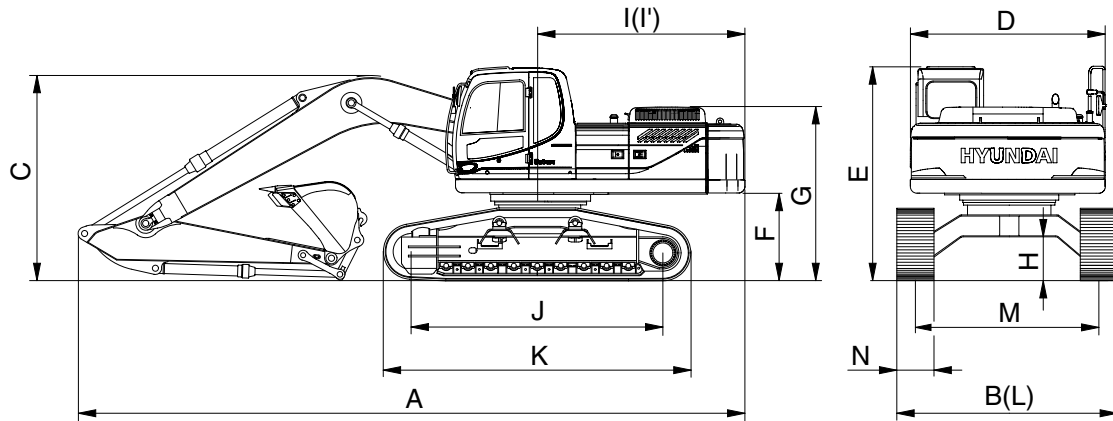

3309A2SP04

Description		Unit	Specification	
Operating weight		kg (lb)	35500 (78260)	
Bucket capacity (SAE heaped), standard		m <sup>3</sup> (yd <sup>3</sup> )	1.44 (1.88)	
Overall length	A	mm (ft-in)	11150 (36' 7")	
Overall width, with 600 mm shoe	B		3470 (11' 5")	
Overall height	C		3360 (11' 0")	
Superstructure width	D		2980 ( 9' 9")	
Overall height of cab	E		3390 (11' 1")	
Ground clearance of counterweight	F		1500 ( 4' 11")	
Engine cover height	G		3055 (10' 0")	
Minimum ground clearance	H		765 ( 2' 6")	
Rear-end distance	I		3504 (11' 6")	
Rear-end swing radius	I'		3560 (11' 8")	
Distance between tumbler	J		4030 (13' 3")	
Undercarriage length	K		4940 (16' 2")	
Undercarriage width	L		3470 (11' 5")	
Track gauge	M		2870 ( 9' 5")	
Track shoe width, standard	N		600 (24")	
Travel speed (low/high)			km/hr (mph)	3.3/5.5 (2.1/3.4)
Swing speed			rpm	9.2
Gradeability		Degree (%)	35 (70)	
Ground pressure (600 mm shoe)		kgf/cm <sup>2</sup> (psi)	0.68 (9.67)	
Max traction force		kg (lb)	29500 (65040)	

### 3. WORKING RANGE

#### 1) R330LC-9A, R330NLC-9A

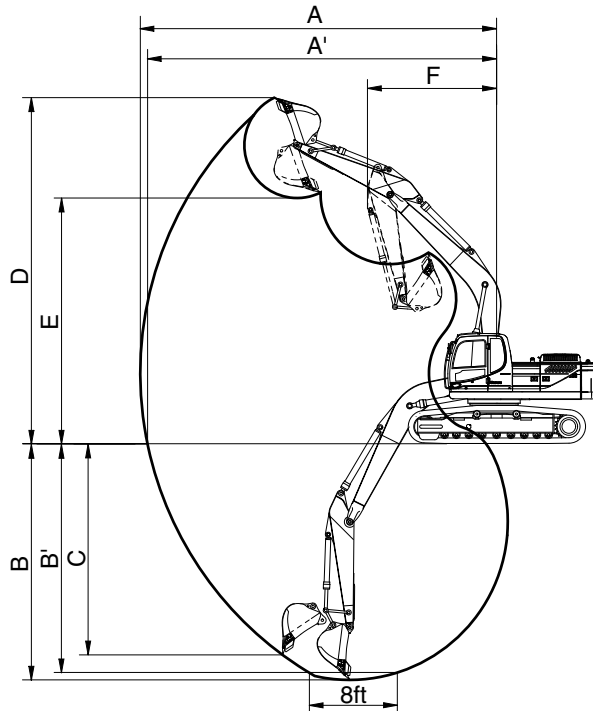

3309A2SP05

Description	6.45 m (21' 2") Boom				6.15 m (20' 2") Boom	
		2.2 m (7' 3") Arm	2.5 m (8' 2") Arm	3.2 m (10' 6") Arm	4.05 m (13' 3") Arm	2.2 m (7' 3") Arm
Max digging reach	A	10330 mm (33'11")	10550 mm (34' 7")	11140 mm (36' 7")	11950 mm (39' 2")	10020 mm (32'10")
Max digging reach on ground	A'	10110 mm (33' 2")	10330 mm (33'11")	10940 mm (35'11")	11760 mm (38' 7")	9800 mm (32' 2")
Max digging depth	B	6370 mm (20'11")	6670 mm (21'11")	7370 mm (24' 2")	8220 mm (26'12")	6160 mm (20' 3")
Max digging depth (8ft level)	B'	6160 mm (20' 3")	6470 mm (21' 3")	7210 mm (23' 8")	8080 mm (26' 6")	5950 mm (19' 6")
Max vertical wall digging depth	C	5980 mm (19' 7")	5920 mm (19' 5")	6360 mm (20'10")	7260 mm (23'10")	5710 mm (18' 9")
Max digging height	D	10220 mm (33' 6")	10170 mm (33' 4")	10310 mm (33'10")	10710 mm (35' 2")	9940 mm (32' 7")
Max dumping height	E	7050 mm (23' 2")	7050 mm (23' 2")	7240 mm (23' 9")	7630 mm (25' 0")	6780 mm (22' 3")
Min swing radius	F	4700 mm (15' 5")	4500 mm (14' 9")	4470 mm (14' 8")	4470 mm (14' 8")	4520 mm (14'10")
Bucket digging force	SAE	189.3 [205.5] kN	189.3 [205.5] kN	189.3 [205.5] kN	189.3 [205.5] kN	189.3 [205.5] kN
		19300 [20950] kgf	19300 [20950] kgf	19300 [20950] kgf	19300 [20950] kgf	19300 [20950] kgf
		42550 [46200] lbf	42550 [46200] lbf	42550 [46200] lbf	42550 [46200] lbf	42550 [46200] lbf
	ISO	211.8 [230.0] kN	211.8 [230.0] kN	211.8 [230.0] kN	211.8 [230.0] kN	211.8 [230.0] kN
		21600 [23450] kgf	21600 [23450] kgf	21600 [23450] kgf	21600 [23450] kgf	21600 [23450] kgf
		47620 [51700] lbf	47620 [51700] lbf	47620 [51700] lbf	47620 [51700] lbf	47620 [51700] lbf
Arm crowd force	SAE	196.6 [213.4] kN	178.9 [194.2] kN	143.2 [155.5] kN	119.6 [129.9] kN	196.6 [213.4] kN
		20000 [21760] kgf	18200 [19810] kgf	14600 [15850] kgf	12200 [13240] kgf	20000 [21760] kgf
		44190 [47980] lbf	40220 [43670] lbf	32190 [34950] lbf	26890 [29190] lbf	44190 [47980] lbf
	ISO	202.8 [220.2] kN	185.1 [201.0] kN	147.1 [159.7] kN	122.7 [133.3] kN	202.8 [220.2] kN
		20700 [22450] kgf	18900 [20500] kgf	15000 [16290] kgf	12515 [13590] kgf	20700 [22450] kgf
		45600 [49510] lbf	41620 [45190] lbf	33070 [35900] lbf	27590 [29950] lbf	45600 [49510] lbf

[ ] : Power boost

## 2) R330LC-9A HIGH WALKER

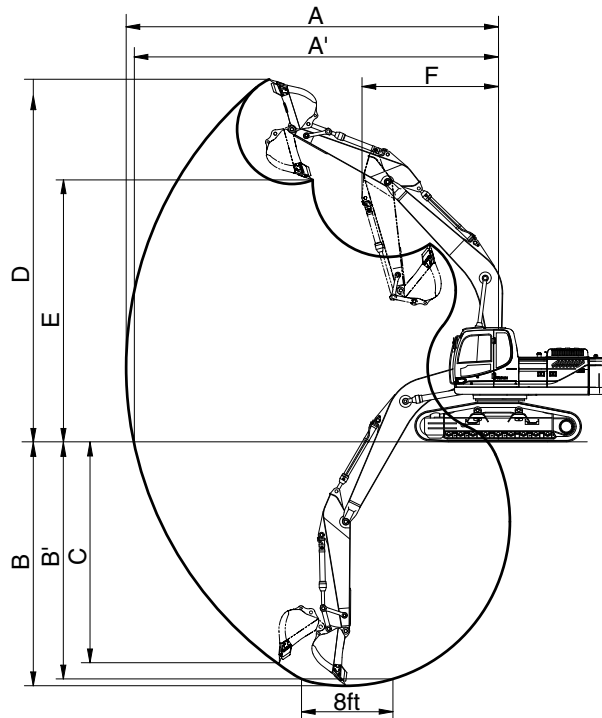

3309A2SP06

Description		6.45 m (21' 2") Boom				6.15 m (20' 2") Boom
		2.2 m (7' 3") Arm	2.5 m (8' 2") Arm	3.2 m (10' 6") Arm	4.05 m (13' 3") Arm	2.2 m (7' 3") Arm
Max digging reach	A	10330 mm (33'11")	10550 mm (34' 7")	11140 mm (36' 7")	11950 mm (39' 2")	10020 mm (32'10")
Max digging reach on ground	A'	10040 mm (32'11")	10270 mm (33' 8")	10880 mm (35' 8")	11710 mm (38' 5")	9730 mm (31'11")
Max digging depth	B	6100 mm (20' 0")	6400 mm (20'12")	7100 mm (23' 4")	7950 mm (26' 1")	5880 mm (19' 3")
Max digging depth (8ft level)	B'	5890 mm (19' 4")	6200 mm (20' 4")	6940 mm (22' 9")	7800 mm (25' 7")	5680 mm (18' 8")
Max vertical wall digging depth	C	5700 mm (18' 8")	5650 mm (18' 6")	6080 mm (19'11")	6980 mm (22'11")	5440 mm (17'10")
Max digging height	D	10500 mm (34' 5")	10450 mm (34' 3")	10590 mm (34' 9")	10990 mm (36' 1")	10220 mm (33' 6")
Max dumping height	E	7330 mm (24' 1")	7330 mm (24' 1")	7520 mm (24' 8")	7910 mm (25'11")	7060 mm (23' 2")
Min swing radius	F	4700 mm (15' 5")	4500 mm (14' 9")	4470 mm (14' 8")	4470 mm (14' 8")	4520 mm (14'10")
Bucket digging force	SAE	[ ]	[ ]	[ ]	[ ]	[ ]
		189.3 [205.5] kN	189.3 [205.5] kN	189.3 [205.5] kN	189.3 [205.5] kN	189.3 [205.5] kN
		19300 [20950] kgf	19300 [20950] kgf	19300 [20950] kgf	19300 [20950] kgf	19300 [20950] kgf
		42550 [46200] lbf	42550 [46200] lbf	42550 [46200] lbf	42550 [46200] lbf	42550 [46200] lbf
	ISO	211.8 [230.0] kN	211.8 [230.0] kN	211.8 [230.0] kN	211.8 [230.0] kN	211.8 [230.0] kN
21600 [23450] kgf		21600 [23450] kgf	21600 [23450] kgf	21600 [23450] kgf	21600 [23450] kgf	
	47620 [51700] lbf	47620 [51700] lbf	47620 [51700] lbf	47620 [51700] lbf	47620 [51700] lbf	
Arm crowd force	SAE	[ ]	[ ]	[ ]	[ ]	[ ]
		196.6 [213.4] kN	178.9 [194.2] kN	143.2 [155.5] kN	119.6 [129.9] kN	196.6 [213.4] kN
		20000 [21760] kgf	18200 [19810] kgf	14600 [15850] kgf	12200 [13240] kgf	20000 [21760] kgf
		44190 [47980] lbf	40220 [43670] lbf	32190 [34950] lbf	26890 [29190] lbf	44190 [47980] lbf
	ISO	202.8 [220.2] kN	185.1 [201.0] kN	147.1 [159.7] kN	122.7 [133.3] kN	202.8 [220.2] kN
20700 [22450] kgf		18900 [20500] kgf	15000 [16290] kgf	12515 [13590] kgf	20700 [22450] kgf	
	45600 [49510] lbf	41620 [45190] lbf	33070 [35900] lbf	27590 [29950] lbf	45600 [49510] lbf	

[ ] : Power boost

## 4. WEIGHT

### 1) R330LC-9A, R330NLC-9A

Item	R330LC-9A		R330NLC-9A	
	kg	lb	kg	lb
Upperstructure assembly	15110	33310	←	←
Main frame weld assembly	3910	8620	←	←
Engine assembly	708	1560	←	←
Main pump assembly	200	440	←	←
Main control valve assembly	220	490	←	←
Swing motor assembly	370	820	←	←
Hydraulic oil tank assembly	230	490	←	←
Fuel tank assembly	240	530	←	←
Counterweight	6000	13230	←	←
Cab assembly	310	680	←	←
Radiator assy	230	510	←	←
Oil cooler assy	80	180	←	←
Lower chassis assembly	11500	25770	11360	25040
Track frame weld assembly	3970	8750	3835	8450
Swing bearing	410	900	←	←
Travel motor assembly	360	800	←	←
Turning joint	50	110	←	←
Tension cylinder	210	450	←	←
Idler	250	540	←	←
Sprocket	80	170	←	←
Carrier roller	40	80	←	←
Track roller	60	120	←	←
Track-chain assembly (600 mm standard triple grouser shoe)	1860	4100	←	←
Front attachment assembly (6.45 m boom, 3.2 m arm, 1.44 m <sup>3</sup> SAE heaped bucket)	6390	14090	←	←
6.45 m boom assembly	2540	5600	←	←
3.2 m arm assembly	1160	2560	←	←
1.44 m <sup>3</sup> SAE heaped bucket	1120	2470	←	←
Boom cylinder assembly	300	660	←	←
Arm cylinder assembly	380	840	←	←
Bucket cylinder assembly	270	570	←	←
Bucket control linkage assembly	370	820	←	←

## 2) R330LC-9A HIGH WALKER

Item	kg	lb
Upperstructure assembly	15110	33310
Main frame weld assembly	3910	8620
Engine assembly	708	1560
Main pump assembly	200	440
Main control valve assembly	220	490
Swing motor assembly	370	820
Hydraulic oil tank assembly	230	490
Fuel tank assembly	240	530
Counterweight	6000	13230
Cab assembly	310	680
Radiator assy	230	510
Oil cooler assy	80	180
Lower chassis assembly	14000	30860
Track frame weld assembly	6180	13620
Swing bearing	410	900
Travel motor assembly	360	800
Turning joint	50	110
Tension cylinder	210	450
Idler	250	540
Sprocket	80	170
Carrier roller	40	80
Track roller	60	120
Track-chain assembly (600 mm standard triple grouser shoe)	1860	4100
Front attachment assembly (6.45 m boom, 3.2 m arm, 1.44 m <sup>3</sup> SAE heaped bucket)	6390	14090
6.45 m boom assembly	2540	5600
3.2 m arm assembly	1160	2560
1.44 m <sup>3</sup> SAE heaped bucket	1120	2470
Boom cylinder assembly	300	660
Arm cylinder assembly	380	840
Bucket cylinder assembly	270	570
Bucket control linkage assembly	370	820

















## 5. LIFTING CAPACITIES

### 1) R330LC-9A

(1) 6.45 m (21' 2") boom, 3.2 m (10' 6") arm equipped with 1.44 m<sup>3</sup> (SAE heaped) bucket and 600 mm (24") triple grouser shoe.

-  : Rating over-front
-  : Rating over-side or 360 degree















Load point height	Load radius												At max. reach			
	1.5 m (5.0 ft)		3.0 m (10.0 ft)		4.5 m (15.0 ft)		6.0 m (20.0 ft)		7.5 m (25.0 ft)		9.0 m (30.0 ft)		Capacity	Reach		
															m (ft)	
7.5 m (25.0 ft)	kg									*5240	*5240			*5970	4490	9.06
	lb									*11550	*11550			*13160	9900	(29.7)
6.0 m (20.0 ft)	kg									*6500	6260			5850	3730	9.84
	lb									*14330	13800			12900	8220	(32.3)
4.5 m (15.0 ft)	kg						*8090	*8090	*7190	6000	*5440	4280	5270	3310	10.31	
	lb						*17840	*17840	*15850	13230	*11990	9440	11620	7300	(33.8)	
3.0 m (10.0 ft)	kg				*13400	12930	*9820	8190	*8110	5690	6520	4120	4990	3090	10.52	
	lb				*29540	28510	*21650	18060	*17880	12540	14370	9080	11000	6810	(34.5)	
1.5 m (5.0 ft)	kg				*16400	11850	*11460	7640	8570	5380	6350	3960	4950	3040	10.48	
	lb				*36160	26120	*25260	16840	18890	11860	14000	8730	10910	6700	(34.4)	
Ground Line	kg			*10240	*10240	*17910	11320	11930	7270	8320	5150	6210	3830	5130	10.19	
	lb			*22580	*22580	*39480	24960	26300	16030	18340	11350	13690	8440	11310	(33.4)	
-1.5 m (-5.0 ft)	kg	*11380	*11380	*14470	*14470	*18150	11170	11730	7090	8180	5030			5620	3470	9.63
	lb	*25090	*25090	*31900	*31900	*40010	24630	25860	15630	18030	11090			12390	7650	(31.6)
-3.0 m (-10.0 ft)	kg	*15350	*15350	*19470	*19470	*17370	11250	11730	7090	8190	5040			6640	4140	8.74
	lb	*33840	*33840	*42920	*42920	*38290	24800	25860	15630	18060	11110			14640	9130	(28.7)
-4.5 m (-15.0 ft)	kg			*21820	*21820	*15410	11530	*11430	7270					*7480	5630	7.37
	lb			*48100	*48100	*33970	25420	*25200	16030					*16490	12410	(24.2)
-6.0 m (-20.0 ft)	kg					*11340	*11340									
	lb					*25000	*25000									

- Note
1. Lifting capacity are based on SAE J1097 and ISO 10567.
  2. Lifting capacity of the ROBEX series does not exceed 75% of tipping load with the machine on firm, level ground or 87% of full hydraulic capacity.
  3. The load point is a hook located on the back of the bucket.
  4. \*indicates load limited by hydraulic capacity.

## 2) R330NLC-9A

(1) 6.45 m (21' 2") boom, 3.2 m (10' 6") arm equipped with 1.44 m<sup>3</sup> (SAE heaped) bucket and 600 mm (24") triple grouser shoe.

-  : Rating over-front
-  : Rating over-side or 360 degree















Load point height		Load radius												At max. reach		
		1.5 m (5.0 ft)		3.0 m (10.0 ft)		4.5 m (15.0 ft)		6.0 m (20.0 ft)		7.5 m (25.0 ft)		9.0 m (30.0 ft)		Capacity	Reach	
																m (ft)
7.5 m (25.0 ft)	kg									*5240	*5240			*5970	3780	9.06
	lb									*11550	*11550			*13160	8330	(29.7)
6.0 m (20.0 ft)	kg									*6500	5130			5810	3100	9.84
	lb									*14330	11710			12810	6830	(32.3)
4.5 m (15.0 ft)	kg							*8090	7460	*7190	5060	*5440	3560	5240	2710	10.31
	lb							*17840	16450	*15850	11160	*11990	7850	11550	5970	(33.8)
3.0 m (10.0 ft)	kg				*13400	10720		*9820	6870	*8110	4750	6480	3410	4690	2510	10.52
	lb				*29540	23630		*21650	15150	*17880	10470	14290	7520	10930	5530	(34.5)
1.5 m (5.0 ft)	kg				*16400	9700		*11460	6340	8520	4460	6300	3250	4910	2460	10.48
	lb				*36160	21380		*25260	13980	18780	9830	13890	7170	10820	5420	(34.4)
Ground Line	kg			*10240	*10240	*17910	9210	11850	5980	8260	4230	6170	3130	5090	2550	10.19
	lb			*22580	*22580	*39480	20300	26120	13180	18210	9330	13600	6900	11220	5620	(33.4)
-1.5 m (-5.0 ft)	kg	*11380	*11380	*14470	*14470	*18150	9070	11650	5180	8130	4120			5580	2820	9.63
	lb	*25090	*25090	*31900	*31900	*40010	20000	25680	12810	17920	9080			12300	6220	(31.6)
-3.0 m (-10.0 ft)	kg	*15350	*15350	*19470	18530	*17370	9140	11650	5810	8130	4120			6590	3400	8.74
	lb	*33840	*33840	*42920	40850	*38290	20150	25680	12810	17920	9080			14530	7500	(28.7)
-4.5 m (-15.0 ft)	kg			*21820	19060	*15410	9400	*11430	5980					*7480	4680	7.37
	lb			*48100	42020	*33970	20720	*25200	13180					*16490	10320	(24.2)
-6.0 m (-20.0 ft)	kg					*11340	9950									
	lb					*25000	21940									

- Note
1. Lifting capacity are based on SAE J1097 and ISO 10567.
  2. Lifting capacity of the ROBEX series does not exceed 75% of tipping load with the machine on firm, level ground or 87% of full hydraulic capacity.
  3. The load point is a hook located on the back of the bucket.
  4. \*indicates load limited by hydraulic capacity.

### 3) R330LC-9A HIGH WALKER

(1) 6.45 m (21' 2") boom, 3.2 m (10' 6") arm equipped with 1.44 m<sup>3</sup> (SAE heaped) bucket and 600 mm (24") triple grouser shoe.

-  : Rating over-front
-  : Rating over-side or 360 degree

Load point height	Load radius												At max. reach		
	1.5 m (5.0 ft)		3.0 m (10.0 ft)		4.5 m (15.0 ft)		6.0 m (20.0 ft)		7.5 m (25.0 ft)		9.0 m (30.0 ft)		Capacity	Reach	
															m (ft)
7.5 m (25.0 ft)	kg								*5730	*5730			*5990	5050	9.24
	lb								*12630	*12630			*13210	11130	(30.3)
6.0 m (20.0 ft)	kg								*6600	*6600			*6130	4300	9.95
	lb								*14550	*14550			*13510	9480	(32.6)
4.5 m (15.0 ft)	kg						*8400	*8400	*7350	6920	*5820	5000	5770	3880	10.37
	lb						*18520	*18520	*16200	15260	*12830	11020	12720	8550	(34.0)
3.0 m (10.0 ft)	kg				*14050	*14050	*10150	9420	*8290	6590	7170	4840	5530	3680	10.53
	lb				*30970	*30970	*22380	20770	*18280	14530	15810	10670	12190	8110	(34.5)
1.5 m (5.0 ft)	kg				*16800	13850	*11720	8890	*9210	6290	7000	4680	5530	3670	10.45
	lb				*37040	30530	*25840	19600	*20300	13870	15430	10320	12190	8090	(34.3)
Ground Line	kg		*10990	*10990	*18040	13400	12750	8540	9150	6080	6880	4570	5790	3840	10.11
	lb		*24230	*24230	*39770	29540	28110	18830	20170	13400	15170	10080	12760	8470	(33.2)
-1.5 m (-5.0 ft)	kg	*12090	*12090	*15330	*15330	*18080	13300	12910	8400	9040	5980		6400	4260	9.50
	lb	*26650	*26650	*33800	*33800	*39860	29320	28460	18520	19930	13180		14110	9390	(31.2)
-3.0 m (-10.0 ft)	kg	*16150	*16150	*20540	*20540	*17110	13410	*12630	8430	9080	6010		*7560	5140	8.53
	lb	*35600	*35600	*45280	*45280	*37720	29560	*27840	18580	20020	13250		*16670	11330	(28.0)
-4.5 m (-15.0 ft)	kg		*20940	*20940	*14870	13750	*10980	8660					*7390	7170	7.03
	lb		*46160	*46160	*32780	30310	*24210	19090					*16290	15810	(23.1)

- Note
1. Lifting capacity are based on SAE J1097 and ISO 10567.
  2. Lifting capacity of the ROBEX series does not exceed 75% of tipping load with the machine on firm, level ground or 87% of full hydraulic capacity.
  3. The load point is a hook located on the back of the bucket.
  4. \*indicates load limited by hydraulic capacity.

## 6. BUCKET SELECTION GUIDE

### 1) GENERAL BUCKET

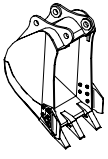
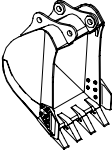
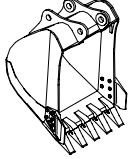
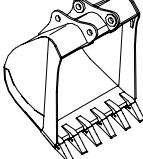
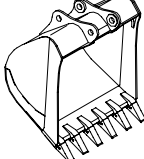
				
0.9 m <sup>3</sup> SAE heaped bucket	1.14 m <sup>3</sup> SAE heaped bucket	1.44 m <sup>3</sup> SAE heaped bucket	1.74 m <sup>3</sup> SAE heaped bucket	2.10 m <sup>3</sup> SAE heaped bucket

Capacity		Width		Weight	Recommendation				
					6.45 m (21' 2") boom				6.15 m (20' 2") boom
SAE heaped	CECE heaped	Without side cutter	With side cutter		2.2 m arm (7' 3")	2.5 m arm (8' 2")	3.2 m arm (10' 6")	4.05 m arm (13' 3")	2.2 m arm (7' 3")
0.9 m <sup>3</sup> (1.18 yd <sup>3</sup> )	0.8 m <sup>3</sup> (1.05 yd <sup>3</sup> )	950 mm (37.4")	1070 mm (42.1")	870 kg (1920 lb)					
1.14 m <sup>3</sup> (1.49 yd <sup>3</sup> )	1.0 m <sup>3</sup> (1.31 yd <sup>3</sup> )	1110 mm (43.7")	1230 mm (48.4")	980 kg (2160 lb)					
1.44 m <sup>3</sup> (1.88 yd <sup>3</sup> )	1.25 m <sup>3</sup> (1.63 yd <sup>3</sup> )	1380 mm (54.3")	1500 mm (59.1")	1110 kg (2450 lb)					
1.74 m <sup>3</sup> (2.28 yd <sup>3</sup> )	1.5 m <sup>3</sup> (1.96 yd <sup>3</sup> )	1620 mm (63.8")	1740 mm (68.5")	1230 kg (2710 lb)					
2.10 m <sup>3</sup> (2.75 yd <sup>3</sup> )	1.8 m <sup>3</sup> (2.35 yd <sup>3</sup> )	1910 mm (75.2")	2030 mm (79.9")	1370 kg (3020 lb)					

 Applicable for materials with density of 2000 kg/m<sup>3</sup> (3370 lb/yd<sup>3</sup>) or less

 Applicable for materials with density of 1600 kg/m<sup>3</sup> (2700 lb/yd<sup>3</sup>) or less

 Applicable for materials with density of 1100 kg/m<sup>3</sup> (1850 lb/yd<sup>3</sup>) or less

## 2) ROCK AND HEAVY DUTY BUCKET

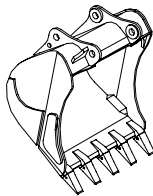
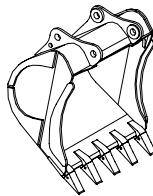
	
<p>◆ 1.44 m<sup>3</sup> SAE heaped bucket</p>	<p>◎ 1.44 m<sup>3</sup> SAE ◎ 1.73 m<sup>3</sup> SAE heaped bucket</p>

Capacity		Width		Weight	Recommendation				
					6.45 m (21' 2") boom				6.15 m (20' 2") boom
SAE heaped	CECE heaped	Without side cutter	With side cutter		2.2 m arm (7' 3")	2.5 m arm (8' 2")	3.2 m arm (10' 6")	4.05 m arm (13' 3")	2.2 m arm (7' 3")
◆ 1.44 m <sup>3</sup> (1.88 yd <sup>3</sup> )	1.25 m <sup>3</sup> (1.63 yd <sup>3</sup> )	1470 mm (57.9")	-	1380 kg (3040 lb)					
◎ 1.44 m <sup>3</sup> (1.88 yd <sup>3</sup> )	1.25 m <sup>3</sup> (1.63 yd <sup>3</sup> )	1470 mm (57.9")	-	1470 kg (3240 lb)					
◎ 1.73 m <sup>3</sup> (2.26 yd <sup>3</sup> )	1.5 m <sup>3</sup> (1.96 yd <sup>3</sup> )	1710 mm (67.3")	-	1610 kg (3550 lb)					

◆ : Heavy duty bucket

◎ : Rock-Heavy duty bucket

Applicable for materials with density of 2000 kg/m<sup>3</sup> (3370 lb/yd<sup>3</sup>) or less

Applicable for materials with density of 1600 kg/m<sup>3</sup> (2700 lb/yd<sup>3</sup>) or less

Applicable for materials with density of 1100 kg/m<sup>3</sup> (1850 lb/yd<sup>3</sup>) or less

## 7. UNDERCARRIAGE

### 1) TRACKS

X-leg type center frame is integrally welded with reinforced box-section track frames. The design includes dry tracks, lubricated rollers, idlers, sprockets, hydraulic track adjusters with shock absorbing springs and assembled track-type tractor shoes with triple grousers.

### 2) TYPES OF SHOES

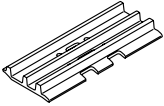
Model	Shapes		Triple grouser			
						
R330LC-9A	Shoe width	mm (in)	600(24)	700(28)	800(32)	900(36)
	Operating weight	kg (lb)	33000(72750)	33600(74070)	34000(74960)	34400(75840)
	Ground pressure	kgf/cm <sup>2</sup> (psi)	0.63(8.96)	0.55(7.82)	0.49(6.97)	0.44(6' 26")
	Overall width	mm (ft-in)	3280(10' 9")	3380(11' 1")	3480(11' 5")	3580(11' 9")
R330NLC-9A	Shoe width	mm (in)	600(24)	-	-	-
	Operating weight	kg (lb)	32800(72310)	-	-	-
	Ground pressure	kgf/cm <sup>2</sup> (psi)	0.63(8.96)	-	-	-
	Overall width	mm (ft-in)	2990(9' 10")	-	-	-
R330LC-9A HIGH WALKER	Shoe width	mm (in)	600(24)	700(28)	800(32)	Double Grouser 710(28)
	Operating weight	kg (lb)	35500(78260)	36100(79590)	36500(80470)	37000(81570)
	Ground pressure	kgf/cm <sup>2</sup> (psi)	0.68(9.67)	0.59(8.39)	0.53(7.54)	0.61(8.67)
	Overall width	mm (ft-in)	3470(11' 5")	3570(11' 9")	3670(12' 0")	3580(11' 9")

### 3) NUMBER OF ROLLERS AND SHOES ON EACH SIDE

Item	Quantity
Carrier rollers	2EA
Track rollers	9EA
Track shoes	48EA

#### 4) SELECTION OF TRACK SHOE

Suitable track shoes should be selected according to operating conditions.

##### Method of selecting shoes

Confirm the category from the list of applications in **table 2**, then use **table 1** to select the shoe. Wide shoes (categories B and C) have limitations on applications. Before using wide shoes, check the precautions, then investigate and study the operating conditions to confirm if these shoes are suitable.

Select the narrowest shoe possible to meet the required flotation and ground pressure. Application of wider shoes than recommendations will cause unexpected problem such as bending of shoes, crack of link, breakage of pin, loosening of shoe bolts and the other various problems.

※ **Table 1**

Track shoe	Specification	Category
600 mm triple grouser	Standard	A
700 mm triple grouser	Option	B
710 mm double grouser	Option	B
800 mm triple grouser	Option	C
900 mm triple grouser	Option	C

※ **Table 2**

Category	Applications	Applications
A	Rocky ground, river beds, normal soil	<ul style="list-style-type: none"> <li>Travel at low speed on rough ground with large obstacles such as boulders or fallen trees</li> </ul>
B	Normal soil, soft ground	<ul style="list-style-type: none"> <li>These shoes cannot be used on rough ground with large obstacles such as boulders or fallen trees</li> <li>Travel at high speed only on flat ground</li> <li>Travel slowly at low speed if it is impossible to avoid going over obstacles</li> </ul>
C	Extremely soft ground (swampy ground)	<ul style="list-style-type: none"> <li>Use the shoes only in the conditions that the machine sinks and it is impossible to use the shoes of category A or B</li> <li>These shoes cannot be used on rough ground with large obstacles such as boulders or fallen trees</li> <li>Travel at high speed only on flat ground</li> <li>Travel slowly at low speed if it is impossible to avoid going over obstacles</li> </ul>

## 8. SPECIFICATIONS FOR MAJOR COMPONENTS

### 1) ENGINE

Item	Specification
Model	Cummins QSL9
Type	4-cycle turbocharged charger air cooled diesel engine
Cooling method	Water cooling
Number of cylinders and arrangement	6 cylinders, in-line
Firing order	1-5-3-6-2-4
Combustion chamber type	Direct injection type
Cylinder bore × stroke	114 × 145 mm (4.49" × 5.69")
Piston displacement	8900 cc (543 cu in)
Compression ratio	17.8 : 1
Rated gross horse power (SAE J1995)	282 Hp at 1750 rpm (210 kW at 1750 rpm)
Maximum torque	123.7 kgf · m (895 lbf · ft) at 1500 rpm
Engine oil quantity	30 l (7.9 U.S. gal)
Wet weight	708 kg (1560 lb)
High idling speed	1800+ 50 rpm
Low idling speed	800 ± 50 rpm
Rated fuel consumption	168 g/Hp · hr at 1750 rpm
Starting motor	Denso 24V-7.8 kW
Alternator	Denso 24V-95A
Battery	2 × 12V × 160Ah

### 2) MAIN PUMP

Item	Specification
Type	Variable displacement tandem axis piston pumps
Capacity	2 × 154 cc/rev
Rated oil flow	2 × 270 l/min (71.3 U.S. gpm / 59.4 U.K. gpm)
Rated speed	1750 rpm



### 3) GEAR PUMP

Item	Specification
Type	Fixed displacement gear pump single stage
Capacity	15cc/rev
Maximum pressure	40 kgf/cm <sup>2</sup> (570 psi)
Rated oil flow	26.3 l /min (6.9 U.S. gpm/5.8 U.K. gpm)

### 4) MAIN CONTROL VALVE

Item	Specification
Type	9 spools
Operating method	Hydraulic pilot system
Main relief valve pressure	350 kgf/cm <sup>2</sup> (4980 psi) [380 kgf/cm <sup>2</sup> (5400 psi)]
Overload relief valve pressure	400 kgf/cm <sup>2</sup> (5690 psi)

[ ]: Power boost

### 5) SWING MOTOR

Item	Specification
Type	Axial piston motor
Capacity	169.4 cc/rev
Relief pressure	300 kgf/cm <sup>2</sup> (4270 psi)
Braking system	Automatic, spring applied hydraulic released
Braking torque	70 kgf · m (505 lbf · ft)
Brake release pressure	26 kgf/cm <sup>2</sup> (370 psi)
Reduction gear type	2 - stage planetary

### 6) TRAVEL MOTOR

Item	Specification
Type	Variable displacement bent-axis axial piston motor
Relief pressure	350 kgf/cm <sup>2</sup> (4980 psi)
Capacity (max / min)	154.8/88.5 cc/rev
Reduction gear type	3-stage planetary
Braking system	Automatic, spring applied hydraulic released
Brake release pressure	9 kgf/cm <sup>2</sup> (128 psi)
Braking torque	40 kgf · m (290 lbf · ft)

## 7) REMOTE CONTROL VALVE

Item		Specification
Type		Pressure reducing type
Operating pressure	Minimum	6.5 kg/cm <sup>2</sup> (92 psi)
	Maximum	26 kg/cm <sup>2</sup> (370 psi)
Single operation stroke	Lever	61 mm (2.4 in)
	Pedal	123 mm (4.84 in)

## 8) CYLINDER

Item		Specification
Boom cylinder	Bore dia × Rod dia × Stroke	∅ 150 × ∅ 105 × 1480 mm
	Cushion	Extend only
Arm cylinder	Bore dia × Rod dia × Stroke	∅ 160 × ∅ 110 × 1685 mm
	Cushion	Extend and retract
Bucket cylinder	Bore dia × Rod dia × Stroke	∅ 140 × ∅ 100 × 1285 mm
	Cushion	Extend only

※ Discoloration of cylinder rod can occur when the friction reduction additive of lubrication oil spreads on the rod surface.

※ Discoloration does not cause any harmful effect on the cylinder performance.

## 9) SHOE

Item		Width	Ground pressure	Link quantity	Overall width
R330LC-9A	Standard	☆600 mm (24")	0.63 kgf/cm <sup>2</sup> (8.96 psi)	48	3280 mm (10' 9")
	Option	☆700 mm (28")	0.55 kgf/cm <sup>2</sup> (7.82 psi)	48	3380 mm (11' 1")
		☆800 mm (32")	0.49 kgf/cm <sup>2</sup> (6.97 psi)	48	3480 mm (11' 5")
		☆900 mm (36")	0.44 kgf/cm <sup>2</sup> (6.26 psi)	48	3580 mm (11' 9")
R330NLC-9A	Standard	☆600 mm (24")	0.63 kgf/cm <sup>2</sup> (8.96 psi)	48	2990 mm ( 9' 10")
R330LC-9A H/WALKER	Standard	☆600 mm (24")	0.68 kgf/cm <sup>2</sup> (9.67 psi)	48	3470 mm (11' 5")
	Option	☆700 mm (28")	0.59 kgf/cm <sup>2</sup> (8.39 psi)	48	3570 mm (11' 9")
		☆800 mm (32")	0.53 kgf/cm <sup>2</sup> (7.54 psi)	48	3670 mm (12' 0")
		★710 mm (28")	0.61 kgf/cm <sup>2</sup> (8.67 psi)	48	3580 mm (11' 9")

☆ : Triple grouser

★ : Double grouser

## 10) BUCKET

Item	Capacity		Tooth quantity	Width	
	SAE heaped	CECE heaped		Without side cutter	With side cutter
R330LC-9A R330NLC-9A H/WALKER	1.44 m <sup>3</sup> (1.88 yd <sup>3</sup> )	1.25 m <sup>3</sup> (1.63 yd <sup>3</sup> )	5	1380 mm (54.3")	1500 mm (59.1")
	0.9 m <sup>3</sup> (1.18 yd <sup>3</sup> )	0.8 m <sup>3</sup> (1.05 yd <sup>3</sup> )	3	950 mm (37.4")	1070 mm (42.1")
	1.14 m <sup>3</sup> (1.49 yd <sup>3</sup> )	1.0 m <sup>3</sup> (1.31 yd <sup>3</sup> )	4	1110 mm (43.7")	1230 mm (48.4")
	1.74 m <sup>3</sup> (2.28 yd <sup>3</sup> )	1.5 m <sup>3</sup> (1.96 yd <sup>3</sup> )	5	1620 mm (63.8")	1740 mm (68.5")
	2.10 m <sup>3</sup> (2.75 yd <sup>3</sup> )	1.8 m <sup>3</sup> (2.35 yd <sup>3</sup> )	5	1910 mm (75.2")	2030 mm (79.9")
	◆1.44 m <sup>3</sup> (1.88 yd <sup>3</sup> )	1.25 m <sup>3</sup> (1.63 yd <sup>3</sup> )	5	1470 mm (57.9")	-
	◎1.44 m <sup>3</sup> (1.88 yd <sup>3</sup> )	1.25 m <sup>3</sup> (1.63 yd <sup>3</sup> )	5	1470 mm (57.9")	-
	◎1.73 m <sup>3</sup> (2.26 yd <sup>3</sup> )	1.5 m <sup>3</sup> (1.96 yd <sup>3</sup> )	5	1710 mm (67.3")	-

◆ : Heavy duty bucket

◎ : Rock-Heavy duty bucket

## 9. RECOMMENDED OILS

Use only oils listed below. Do not mix different brand oil.

Please use HYUNDAI genuine oil and grease.

Service point	Kind of fluid	Capacity ℓ (U.S. gal)	Ambient temperature °C (°F)						
			-50 (-58)	-30 (-22)	-20 (-4)	-10 (14)	0 (32)	10 (50)	20 (68)
Engine oil pan	Engine oil	30 (7.9)	★SAE 5W-40						
			SAE 30						
			SAE 10W						
			SAE 10W-30						
			SAE 15W-40						
Swing drive	Gear oil	8.0 (2.1)	★SAE 75W-90						
Final drive		8.0×2 (2.1×2)	SAE 80W-90						
Hydraulic tank	Hydraulic oil	Tank: 210 (55.5) System: 330 (87)	★ISO VG 15						
			ISO VG 32						
			ISO VG 46						
			ISO VG 68						
Fuel tank	Diesel fuel★ <sup>1</sup>	550 (145)	★ASTM D975 NO.1						
			ASTM D975 NO.2						
Fitting (grease nipple)	Grease	As required	★NLGI NO.1						
			NLGI NO.2						
Radiator (reservoir tank)	Mixture of antifreeze and water	55 (14.5)	Ethylene glycol base permanent type (50 : 50)						
			★Ethylene glycol base permanent type (60 : 40)						

**SAE** : Society of Automotive Engineers

**API** : American Petroleum Institute

**ISO** : International Organization for Standardization

**NLGI** : National Lubricating Grease Institute

**ASTM** : American Society of Testing and Material

★<sup>1</sup> Ultra low sulfur diesel

- sulfur content ≤ 15 ppm

★ : Cold region

Russia, CIS, Mongolia