

GROUP 2 SPECIFICATIONS

1. MAJOR COMPONENT

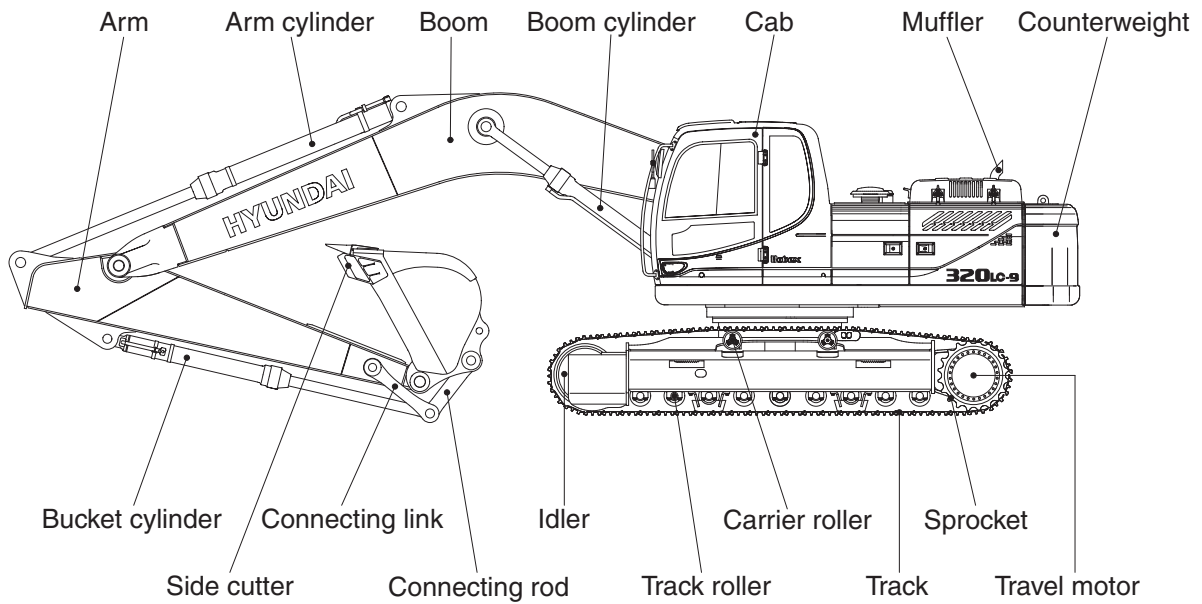
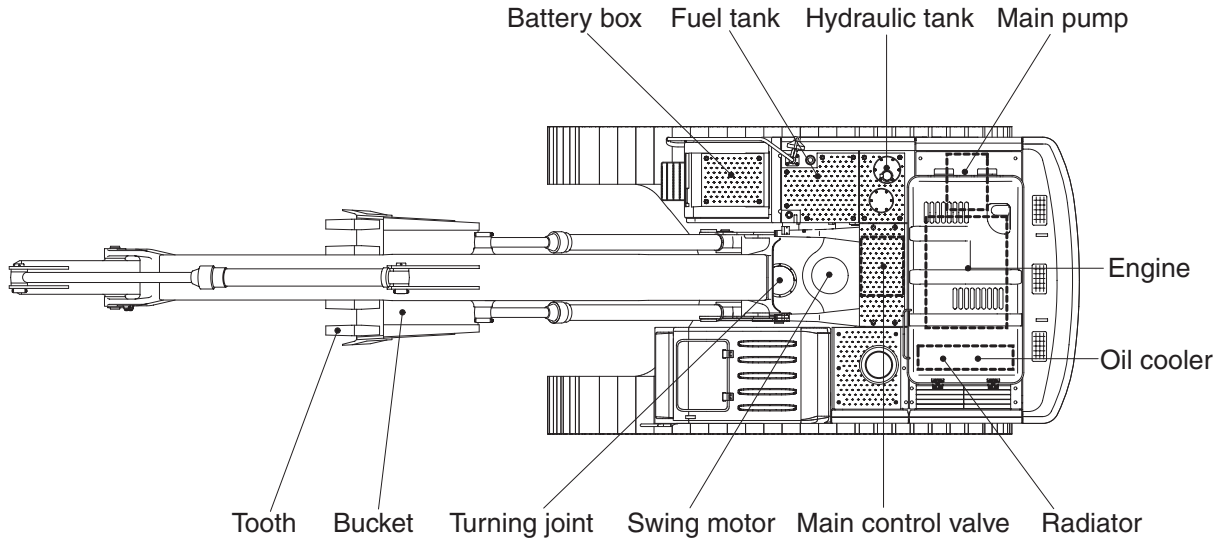

32092SP01A

2. SPECIFICATIONS

1) R320LC-9

- 6.45 m (21' 2") BOOM and 3.20 m (10' 6") ARM

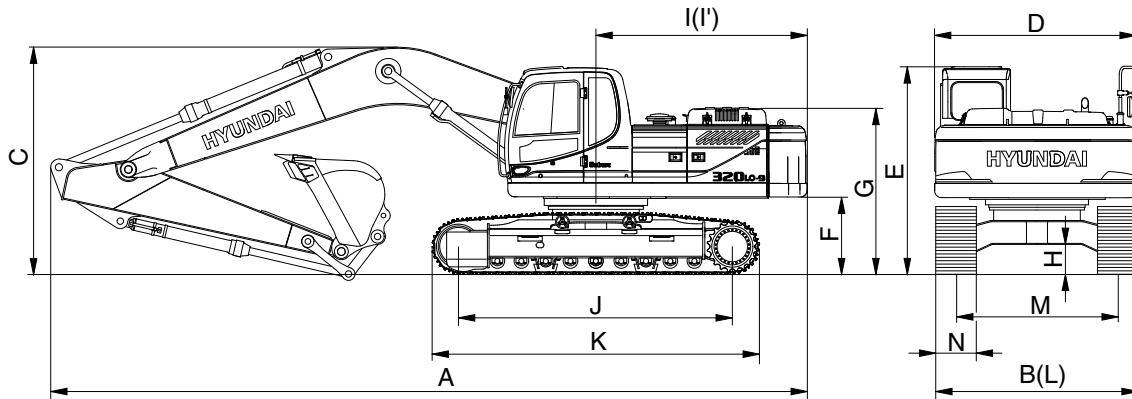

32092SP02

Description		Unit	Specification
Operating weight		kg (lb)	33000 (72750)
Bucket capacity (SAE heaped), standard		m ³ (yd ³)	1.44 (1.88)
Overall length	A	mm (ft-in)	10980 (36' 0")
Overall width, with 600 mm shoe	B		3280 (10' 9")
Overall height	C		3380 (11' 1")
Superstructure width	D		2980 (9' 9")
Overall height of cab	E		3090 (10' 2")
Ground clearance of counterweight	F		1200 (3' 11")
Engine cover height	G		2580 (8' 6")
Minimum ground clearance	H		500 (1' 8")
Rear-end distance	I		3265 (10' 9")
Rear-end swing radius	I'		3330 (10' 11")
Distance between tumblers	J		4030 (13' 3")
Undercarriage length	K		4940 (16' 2")
Undercarriage width	L		3280 (10' 9")
Track gauge	M		2680 (8' 10")
Track shoe width, standard	N		600 (24")
Travel speed (low/high)			km/hr (mph)
Swing speed		rpm	9.2
Gradeability		Degree (%)	35 (70)
Ground pressure (600 mm shoe)		kgf/cm ² (psi)	0.63 (8.96)
Max traction force		kg (lb)	29500 (65040)

2) R320NLC-9

· 6.45 m (21' 2") BOOM and 3.20 m (10' 6") ARM

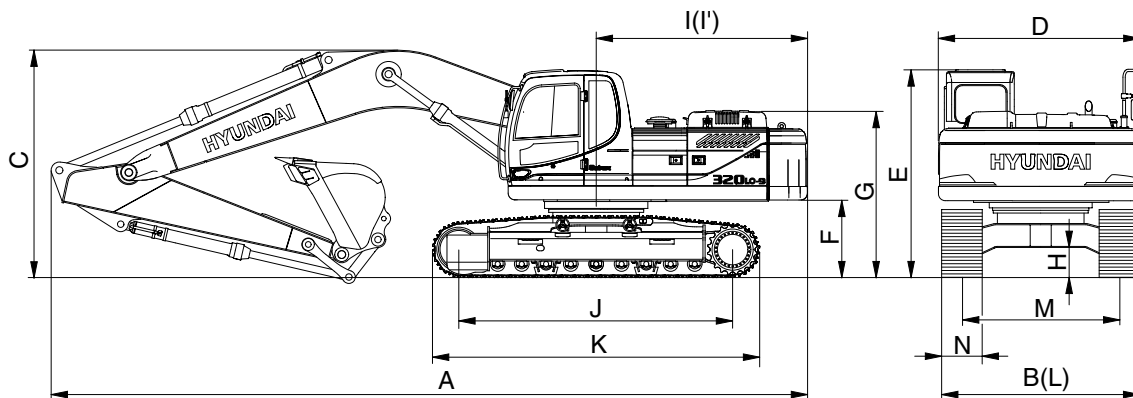

32092SP03

Description		Unit	Specification
Operating weight		kg (lb)	32000 (70500)
Bucket capacity (SAE heaped), standard		m ³ (yd ³)	1.44 (1.88)
Overall length	A	mm (ft-in)	10980 (36' 0")
Overall width, with 600 mm shoe	B		2990 (9' 10")
Overall height	C		3380 (11' 1")
Superstructure width	D		2980 (9' 9")
Overall height of cab	E		3090 (10' 2")
Ground clearance of counterweight	F		1200 (3' 11")
Engine cover height	G		2580 (8' 6")
Minimum ground clearance	H		500 (1' 8")
Rear-end distance	I		3265 (10' 9")
Rear-end swing radius	I'		3330 (10' 11")
Distance between tumblers	J		4030 (13' 3")
Undercarriage length	K		4940 (16' 2")
Undercarriage width	L		2990 (9' 10")
Track gauge	M		2390 (7' 10")
Track shoe width, standard	N		600 (24")
Travel speed (low/high)			km/hr (mph)
Swing speed		rpm	9.2
Gradeability		Degree (%)	35 (70)
Ground pressure (600 mm shoe)		kgf/cm ² (psi)	0.61 (8.67)
Max traction force		kg (lb)	29500 (65040)

3) R320LC-9 HIGH WALKER

· 6.45 m (21' 2") BOOM and 3.20 m (10' 6") ARM

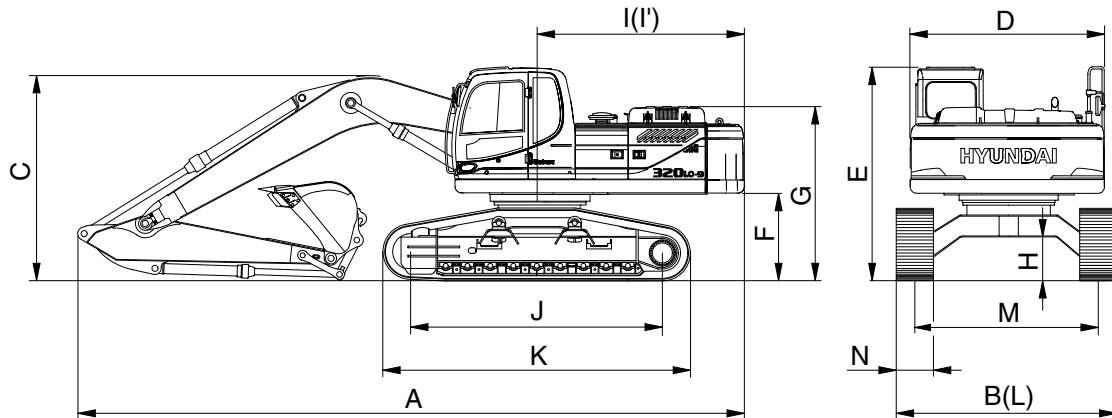

32092SP04

Description		Unit	Specification
Operating weight		kg (lb)	34700 (76500)
Bucket capacity (SAE heaped), standard		m ³ (yd ³)	1.44 (1.88)
Overall length	A	mm (ft-in)	10910 (35' 10")
Overall width, with 600 mm shoe	B		3470 (11' 5")
Overall height	C		3360 (11' 0")
Superstructure width	D		2980 (9' 9")
Overall height of cab	E		3390 (11' 1")
Ground clearance of counterweight	F		1500 (4' 11")
Engine cover height	G		2880 (9' 5")
Minimum ground clearance	H		765 (2' 6")
Rear-end distance	I		3265 (10' 9")
Rear-end swing radius	I'		3330 (10' 11")
Distance between tumbler	J		4030 (13' 3")
Undercarriage length	K		4940 (16' 2")
Undercarriage width	L		3470 (11' 5")
Track gauge	M		2870 (9' 5")
Track shoe width, standard	N		600 (24")
Travel speed (low/high)			km/hr (mph)
Swing speed		rpm	9.2
Gradeability		Degree (%)	35 (70)
Ground pressure (600 mm shoe)		kgf/cm ² (psi)	0.67 (9.53)
Max traction force		kg (lb)	29500 (65040)

3. WORKING RANGE

1) R320LC-9, R320NLC-9

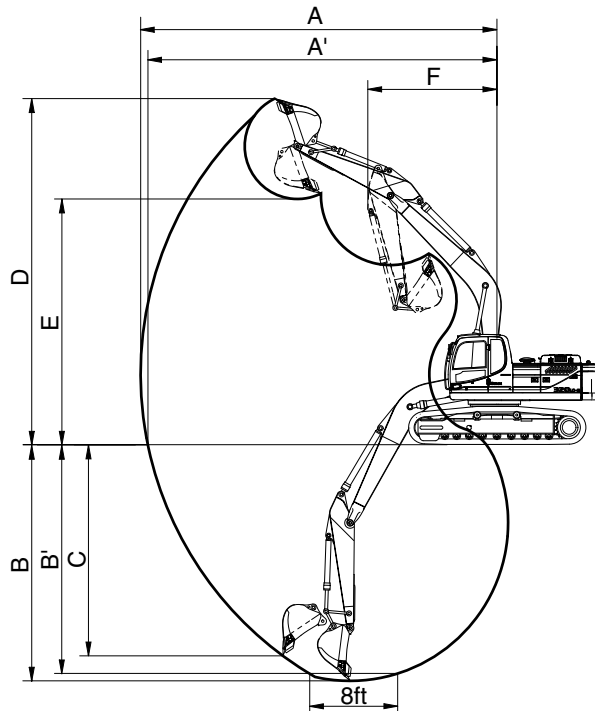

32092SP05

Description	6.45 m (21' 2") Boom					6.15 m (20' 2") Boom
		2.2 m (7' 3") Arm	2.5 m (8' 2") Arm	3.2 m (10' 6") Arm	4.05 m (13' 3") Arm	2.2 m (7' 3") Arm
Max digging reach	A	10330 mm (33'11")	10550 mm (34' 7")	11140 mm (36' 7")	11950 mm (39' 2")	10020 mm (32'10")
Max digging reach on ground	A'	10110 mm (33' 2")	10330 mm (33'11")	10940 mm (35'11")	11760 mm (38' 7")	9800 mm (32' 2")
Max digging depth	B	6370 mm (20'11")	6670 mm (21'11")	7370 mm (24' 2")	8220 mm (26'12")	6160 mm (20' 3")
Max digging depth (8ft level)	B'	6160 mm (20' 3")	6470 mm (21' 3")	7210 mm (23' 8")	8080 mm (26' 6")	5950 mm (19' 6")
Max vertical wall digging depth	C	5980 mm (19' 7")	5920 mm (19' 5")	6360 mm (20'10")	7260 mm (23'10")	5710 mm (18' 9")
Max digging height	D	10220 mm (33' 6")	10170 mm (33' 4")	10310 mm (33'10")	10710 mm (35' 2")	9940 mm (32' 7")
Max dumping height	E	7050 mm (23' 2")	7050 mm (23' 2")	7240 mm (23' 9")	7630 mm (25' 0")	6780 mm (22' 3")
Min swing radius	F	4700 mm (15' 5")	4500 mm (14' 9")	4470 mm (14' 8")	4470 mm (14' 8")	4520 mm (14'10")
Bucket digging force	SAE	189.3 [205.5] kN	189.3 [205.5] kN	189.3 [205.5] kN	189.3 [205.5] kN	189.3 [205.5] kN
		19300 [20950] kgf	19300 [20950] kgf	19300 [20950] kgf	19300 [20950] kgf	19300 [20950] kgf
		42550 [46200] lbf	42550 [46200] lbf	42550 [46200] lbf	42550 [46200] lbf	42550 [46200] lbf
	ISO	211.8 [230.0] kN	211.8 [230.0] kN	211.8 [230.0] kN	211.8 [230.0] kN	211.8 [230.0] kN
		21600 [23450] kgf	21600 [23450] kgf	21600 [23450] kgf	21600 [23450] kgf	21600 [23450] kgf
		47620 [51700] lbf	47620 [51700] lbf	47620 [51700] lbf	47620 [51700] lbf	47620 [51700] lbf
Arm crowd force	SAE	196.6 [213.4] kN	178.9 [194.2] kN	143.2 [155.5] kN	119.6 [129.9] kN	196.6 [213.4] kN
		20000 [21760] kgf	18200 [19810] kgf	14600 [15850] kgf	12200 [13240] kgf	20000 [21760] kgf
		44190 [47980] lbf	40220 [43670] lbf	32190 [34950] lbf	26890 [29190] lbf	44190 [47980] lbf
	ISO	202.8 [220.2] kN	185.1 [201.0] kN	147.1 [159.7] kN	122.7 [133.3] kN	202.8 [220.2] kN
		20700 [22450] kgf	18900 [20500] kgf	15000 [16290] kgf	12515 [13590] kgf	20700 [22450] kgf
		45600 [49510] lbf	41620 [45190] lbf	33070 [35900] lbf	27590 [29950] lbf	45600 [49510] lbf

[] : Power boost

2) R320LC-9 HIGH WALKER

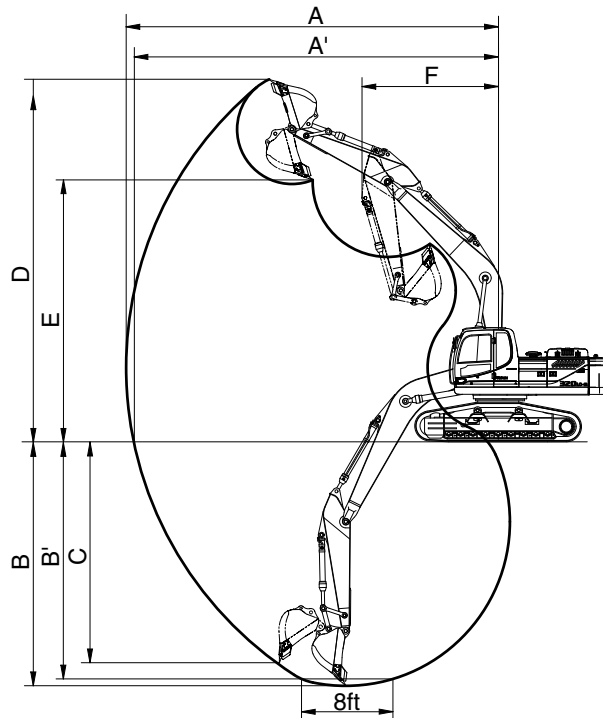

32092SP06

Description		6.45 m (21' 2") Boom				6.15 m (20' 2") Boom
		2.2 m (7' 3") Arm	2.5 m (8' 2") Arm	3.2 m (10' 6") Arm	4.05 m (13' 3") Arm	2.2 m (7' 3") Arm
Max digging reach	A	10330 mm (33'11")	10550 mm (34' 7")	11140 mm (36' 7")	11950 mm (39' 2")	10020 mm (32'10")
Max digging reach on ground	A'	10040 mm (32'11")	10270 mm (33' 8")	10880 mm (35' 8")	11710 mm (38' 5")	9730 mm (31'11")
Max digging depth	B	6100 mm (20' 0")	6400 mm (20'12")	7100 mm (23' 4")	7950 mm (26' 1")	5880 mm (19' 3")
Max digging depth (8ft level)	B'	5890 mm (19' 4")	6200 mm (20' 4")	6940 mm (22' 9")	7800 mm (25' 7")	5680 mm (18' 8")
Max vertical wall digging depth	C	5700 mm (18' 8")	5650 mm (18' 6")	6080 mm (19'11")	6980 mm (22'11")	5440 mm (17'10")
Max digging height	D	10500 mm (34' 5")	10450 mm (34' 3")	10590 mm (34' 9")	10990 mm (36' 1")	10220 mm (33' 6")
Max dumping height	E	7330 mm (24' 1")	7330 mm (24' 1")	7520 mm (24' 8")	7910 mm (25'11")	7060 mm (23' 2")
Min swing radius	F	4700 mm (15' 5")	4500 mm (14' 9")	4470 mm (14' 8")	4470 mm (14' 8")	4520 mm (14'10")
Bucket digging force	SAE	189.3 [205.5] kN	189.3 [205.5] kN	189.3 [205.5] kN	189.3 [205.5] kN	189.3 [205.5] kN
		19300 [20950] kgf	19300 [20950] kgf	19300 [20950] kgf	19300 [20950] kgf	19300 [20950] kgf
		42550 [46200] lbf	42550 [46200] lbf	42550 [46200] lbf	42550 [46200] lbf	42550 [46200] lbf
	ISO	211.8 [230.0] kN	211.8 [230.0] kN	211.8 [230.0] kN	211.8 [230.0] kN	211.8 [230.0] kN
		21600 [23450] kgf	21600 [23450] kgf	21600 [23450] kgf	21600 [23450] kgf	21600 [23450] kgf
		47620 [51700] lbf	47620 [51700] lbf	47620 [51700] lbf	47620 [51700] lbf	47620 [51700] lbf
Arm crowd force	SAE	196.6 [213.4] kN	178.9 [194.2] kN	143.2 [155.5] kN	119.6 [129.9] kN	196.6 [213.4] kN
		20000 [21760] kgf	18200 [19810] kgf	14600 [15850] kgf	12200 [13240] kgf	20000 [21760] kgf
		44190 [47980] lbf	40220 [43670] lbf	32190 [34950] lbf	26890 [29190] lbf	44190 [47980] lbf
	ISO	202.8 [220.2] kN	185.1 [201.0] kN	147.1 [159.7] kN	122.7 [133.3] kN	202.8 [220.2] kN
		20700 [22450] kgf	18900 [20500] kgf	15000 [16290] kgf	12515 [13590] kgf	20700 [22450] kgf
		45600 [49510] lbf	41620 [45190] lbf	33070 [35900] lbf	27590 [29950] lbf	45600 [49510] lbf

[] : Power boost

4. WEIGHT

1) R320LC-9, R320NLC-9

Item	R320LC-9		R320NLC-9	
	kg	lb	kg	lb
Upperstructure assembly	14310	31550	←	←
Main frame weld assembly	3760	8290	←	←
Engine assembly	720	1590	←	←
Main pump assembly	200	440	←	←
Main control valve assembly	220	490	←	←
Swing motor assembly	370	820	←	←
Hydraulic oil tank assembly	230	490	←	←
Fuel tank assembly	210	450	←	←
Counterweight	6200	13670	←	←
Cab assembly	310	680	←	←
Radiator total assy	280	620	←	←
Lower chassis assembly	11500	25770	11360	25040
Track frame weld assembly	3970	8750	3835	8450
Swing bearing	410	900	←	←
Travel motor assembly	360	800	←	←
Turning joint	50	110	←	←
Tension cylinder	210	450	←	←
Idler	250	540	←	←
Sprocket	80	170	←	←
Carrier roller	40	80	←	←
Track roller	60	120	←	←
Track-chain assembly (600 mm standard triple grouser shoe)	1860	4100	←	←
Front attachment assembly (6.45 m boom, 3.2 m arm, 1.44 m ³ SAE heaped bucket)	6390	14090	←	←
6.45 m boom assembly	2540	5600	←	←
3.2 m arm assembly	1160	2560	←	←
1.44 m ³ SAE heaped bucket	1120	2470	←	←
Boom cylinder assembly	300	660	←	←
Arm cylinder assembly	380	840	←	←
Bucket cylinder assembly	270	570	←	←
Bucket control linkage assembly	370	820	←	←

2) R320LC-9 HIGH WALKER

Item	kg	lb
Upperstructure assembly	14310	31550
Main frame weld assembly	3760	8290
Engine assembly	720	1590
Main pump assembly	200	440
Main control valve assembly	220	490
Swing motor assembly	370	820
Hydraulic oil tank assembly	230	490
Fuel tank assembly	210	450
Counterweight	6200	13670
Cab assembly	310	680
Radiator total assy	280	620
Lower chassis assembly	14000	30860
Track frame weld assembly	6180	13620
Swing bearing	410	900
Travel motor assembly	360	800
Turning joint	50	110
Tension cylinder	210	450
Idler	250	540
Sprocket	80	170
Carrier roller	40	80
Track roller	60	120
Track-chain assembly (600 mm standard triple grouser shoe)	1860	4100
Front attachment assembly (6.45 m boom, 3.2 m arm, 1.44 m ³ SAE heaped bucket)	6390	14090
6.45 m boom assembly	2540	5600
3.2 m arm assembly	1160	2560
1.44 m ³ SAE heaped bucket	1120	2470
Boom cylinder assembly	300	660
Arm cylinder assembly	380	840
Bucket cylinder assembly	270	570
Bucket control linkage assembly	370	820











5. LIFTING CAPACITIES

1) R320LC-9

(1) 6.15 m (20' 2") boom, 2.2 m (7' 3") arm equipped with 1.44 m³ (SAE heaped) bucket and 600 mm (24") triple grouser shoe and 6200 kg (13670 lb) counterweight.















•  : Rating over-front

•  : Rating over-side or 360 degree

Load point height		Load radius								At max. reach		
		3.0 m (10.0 ft)		4.5 m (15.0 ft)		6.0m (20.0 ft)		7.5 m (25.0 ft)		Capacity		Reach
												m (ft)
7.5 m (25.0 ft)	kg lb									*7480 *16490	5680 12520	7.69 (25.2)
6.0 m (20.0 ft)	kg lb					*8380 *18470	*8380 *18470	*8070 *17790	5770 12720	7000 15430	4510 9940	8.61 (28.2)
4.5 m (15.0 ft)	kg lb			*12080 *26630	*12080 *26630	*9630 *21230	8260 18210	*8490 *18720	5630 12410	6170 13600	3920 8640	9.16 (30.1)
3.0 m (10.0 ft)	kg lb			*15590 *34370	12100 26680	*11230 *24760	7760 17110	8490 18720	5400 11900	5810 12810	3650 8050	9.39 (30.8)
1.5 m (5.0 ft)	kg lb			*18040 *39770	11310 24930	11860 26150	7330 16160	8250 18190	5180 11420	5780 12740	3610 7960	9.35 (30.7)
Ground Line	kg lb			*18760 *41360	11030 24320	11570 25510	7080 15610	8080 17810	5030 11090	6090 13430	3800 8380	9.02 (29.6)
-1.5 m (-5.0 ft)	kg lb	*16910 37280	*16910 *37280	*18280 *40300	11030 24320	11490 25330	7000 15430	8050 17750	5000 11020	6900 15210	4330 9550	8.37 (27.5)
-3.0 m (-10 ft)	kg lb	*22970 *50640	*22970 *50640	*16680 *36770	11210 24710	11600 25570	7100 15650			*8360 *18430	5530 12190	7.29 (23.9)
-4.5 m (-15.0 ft)	kg lb	*17920 *39510	*17920 *39510	*13190 *29080	11640 25660							















- Note
1. Lifting capacity are based on SAE J1097 and ISO 10567.
 2. Lifting capacity of the ROBEX series does not exceed 75% of tipping load with the machine on firm, level ground or 87% of full hydraulic capacity.
 3. The load point is a hook located on the back of the bucket.
 4. *indicates load limited by hydraulic capacity.

(2) 6.45 m (21' 2") boom, 3.2 m (10' 6") arm equipped with 1.44 m³ (SAE heaped) bucket and 600 mm (24") triple grouser shoe and 6200 kg (13670 lb) counterweight.

Load point height		Load radius												At max. reach		
		1.5 m (5.0 ft)		3.0 m (10.0 ft)		4.5 m (15.0 ft)		6.0 m (20.0 ft)		7.5 m (25.0 ft)		9.0 m (30.0 ft)		Capacity		Reach
																m (ft)
7.5 m (25.0 ft)	kg									*5240	*5240			*5970	4180	9.06
	lb									*11550	*11550			*13160	9220	(29.7)
6.0 m (20.0 ft)	kg									*6500	5860			5490	3450	9.84
	lb									*14330	12920			12100	7610	(32.3)
4.5 m (15.0 ft)	kg							*8090	*8090	*7190	5610	*5440	3960	4930	3040	10.31
	lb							*17840	*17840	*15850	12370	*11990	8730	10870	6700	(33.8)
3.0 m (10.0 ft)	kg				*13400	12150	*9820	7670	*8110	5290	6120	3810	4660	2830	10.52	
	lb				*29540	26790	*21650	16910	*17880	11660	13490	8400	10270	6240	(34.5)	
1.5 m (5.0 ft)	kg				*16400	11070	*11460	7120	8060	4990	5940	3640	4610	2780	10.48	
	lb				*36160	24410	*25260	15700	17770	11000	13100	8020	10160	6130	(34.4)	
Ground Line	kg			*10240	*10240	*17910	10550	11220	6750	7800	4760	5810	3520	4790	2880	10.19
	lb			*22580	*22580	*39480	23260	24740	14880	17200	10490	12810	7760	10560	6350	(33.4)
-1.5 m (-5.0 ft)	kg	*11380	*11380	*14470	*14470	*18150	10400	11020	6570	7670	4640			5250	3180	9.63
	lb	*25090	*25090	*31900	*31900	*40010	22930	24290	14480	16910	10230			11570	7010	(31.6)
-3.0 m (-10.0 ft)	kg	*15350	*15350	*19470	*19470	*17370	10480	11020	6570	7680	4640			6220	3820	8.74
	lb	*33840	*33840	*42920	*42920	*38290	23100	24290	14480	16930	10230			13710	8420	(28.7)
-4.5 m (-15.0 ft)	kg			*21820	*21820	*15410	10760	11230	6750					*7480	5230	7.37
	lb			*48100	*48100	*33970	23720	24760	14880					*16490	11530	(24.2)
-6.0 m (-20.0 ft)	kg					*11340	11330									
	lb					*25000	24980									

2) R320NLC-9















(1) 6.45 m (21' 2") boom, 3.2 m (10' 6") arm equipped with 1.44 m³ (SAE heaped) bucket and 600 mm (24") triple grouser shoe and 6200 kg (13670 lb) counterweight.

Load point height		Load radius												At max. reach		
		1.5 m (5.0 ft)		3.0 m (10.0 ft)		4.5 m (15.0 ft)		6.0 m (20.0 ft)		7.5 m (25.0 ft)		9.0 m (30.0 ft)		Capacity		Reach
																
7.5 m (25.0 ft)	kg									*5240	5060			*5970	3490	9.06
	lb									*11550	11160			*13160	7690	(29.7)
6.0 m (20.0 ft)	kg									*6500	4950			5450	2840	9.84
	lb									*14330	10910			12020	6260	(32.3)
4.5 m (15.0 ft)	kg							*8090	6990	*7190	4700	*5440	3270	4900	2470	10.31
	lb							*17840	15410	*15850	10360	*11990	7210	10800	5450	(33.8)
3.0 m (10.0 ft)	kg				*13400	10030		*9820	6400	*8110	4400	6070	3120	4630	2270	10.52
	lb				*29540	22110		*21650	14110	*17880	9700	13380	6880	10210	5000	(34.5)
1.5 m (5.0 ft)	kg				*16400	9010		*11460	5870	8000	4100	5900	2960	4580	2220	10.48
	lb				*36160	19860		*25260	12940	17640	9040	13010	6530	10100	4890	(34.4)
Ground Line	kg			*10240	*10240	*17910	8520	11150	5510	7750	3880	5760	2840	4750	2300	10.19
	lb			*22580	*22580	*39480	18780	24580	12150	17090	8550	12700	6260	10470	5070	(33.4)
-1.5 m (-5.0 ft)	kg	*11380	*11380	*14470	*14470	*18150	8380	10950	5340	7610	3760			5210	2560	9.63
	lb	*25090	*25090	*31900	*31900	*40010	18470	24140	11770	16780	8290			11490	5640	(31.6)
-3.0 m (-10.0 ft)	kg	*15350	*15350	*19470	17250	*17370	8450	10950	5340	7620	3770			6170	3100	8.74
	lb	*33840	*33840	*42920	38030	*38290	18630	24140	11770	16800	8310			13600	6830	(28.7)
-4.5 m (-15.0 ft)	kg			*21820	17780	*15410	8720	11150	5510					*7480	4310	7.37
	lb			*48100	39200	*33970	19220	24580	12150					*16490	9500	(24.2)
-6.0 m (-20.0 ft)	kg					*11340	9260									
	lb					*25000	20410									

- Note
1. Lifting capacity are based on SAE J1097 and ISO 10567.
 2. Lifting capacity of the ROBEX series does not exceed 75% of tipping load with the machine on firm, level ground or 87% of full hydraulic capacity.
 3. The load point is a hook located on the back of the bucket.
 4. *indicates load limited by hydraulic capacity.

3) R320LC-9 HIGH WALKER

(1) 6.45 m (21' 2") boom, 3.2 m (10' 6") arm equipped with 1.44 m³ (SAE heaped) bucket and 600 mm (24") triple grouser shoe and 6200 kg (13670 lb) counterweight.

Load point height		Load radius												At max. reach		
		1.5 m (5.0 ft)		3.0 m (10.0 ft)		4.5 m (15.0 ft)		6.0 m (20.0 ft)		7.5 m (25.0 ft)		9.0 m (30.0 ft)		Capacity		Reach
																m (ft)
7.5 m (25.0 ft)	kg									*5730	*5730			*5990	4770	9.24
	lb									*12630	*12630			*13210	10520	(30.3)
6.0 m (20.0 ft)	kg									*6600	*6600			*6010	4040	9.95
	lb									*14550	*14550			*13250	8910	(32.6)
4.5 m (15.0 ft)	kg							*8400	*8400	*7350	6560	*5820	4720	5490	3640	10.37
	lb							*18520	*18520	*16200	14460	*12830	10410	12100	8020	(34.0)
3.0 m (10.0 ft)	kg				*14050	*14050	*10150	8950	*8290	6240	6830	4560	5250	3450	10.53	
	lb				*30970	*30970	*22380	19730	*18280	13760	15060	10050	11570	7610	(34.5)	
1.5 m (5.0 ft)	kg				*16800	13130	*11720	8410	8950	5940	6660	4400	5240	3430	10.45	
	lb				*37040	28950	*25840	18540	19730	13100	14680	9700	11550	7560	(34.3)	
Ground Line	kg			*10990	*10990	*18040	12680	12470	8070	8710	5720	6530	4280	5490	3590	10.11
	lb			*24230	*24230	*39770	27950	27490	17790	19200	12610	14400	9440	12100	7910	(33.2)
-1.5 m (-5.0 ft)	kg	*12090	*12090	*15330	*15330	*18080	12580	12310	7920	8600	5620			6080	3990	9.50
	lb	*26650	*26650	*33800	*33800	*39860	27730	27140	17460	18960	12390			13400	8800	(31.2)
-3.0 m (-10.0 ft)	kg	*16150	*16150	*20540	*20540	*17110	12700	12340	7960	8640	5660			7290	4830	8.53
	lb	*35600	*35600	*45280	*45280	*37720	28000	27210	17550	19050	12480			16070	10650	(28.0)
-4.5 m (-15.0 ft)	kg			*20940	*20940	*14870	13030	*10980	8180					*7390	6780	7.03
	lb			*46160	*46160	*32780	28730	*24210	18030					*16290	14950	(23.1)

- Note
1. Lifting capacity are based on SAE J1097 and ISO 10567.
 2. Lifting capacity of the ROBEX series does not exceed 75% of tipping load with the machine on firm, level ground or 87% of full hydraulic capacity.
 3. The load point is a hook located on the back of the bucket.
 4. * indicates load limited by hydraulic capacity.

6. BUCKET SELECTION GUIDE

1) GENERAL BUCKET

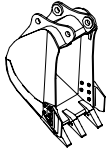
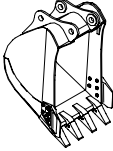
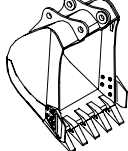
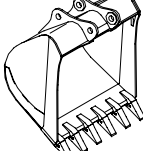
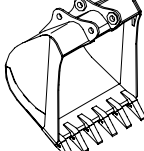
				
0.9 m ³ SAE heaped bucket	1.14 m ³ SAE heaped bucket	※ 1.44 m ³ SAE heaped bucket	1.74 m ³ SAE heaped bucket	2.10 m ³ SAE heaped bucket

Capacity		Width		Weight	Recommendation				
					6.45 m (21' 2") boom				6.15 m (20' 2") boom
SAE heaped	CECE heaped	Without side cutter	With side cutter		2.2 m arm (7' 3")	2.5 m arm (8' 2")	3.2 m arm (10' 6")	4.05 m arm (13' 3")	2.2 m arm (7' 3")
0.9 m ³ (1.18 yd ³)	0.8 m ³ (1.05 yd ³)	950 mm (37.4")	1070 mm (42.1")	870 kg (1920 lb)					
1.14 m ³ (1.49 yd ³)	1.0 m ³ (1.31 yd ³)	1110 mm (43.7")	1230 mm (48.4")	980 kg (2160 lb)					
※ 1.44 m ³ (1.88 yd ³)	1.25 m ³ (1.63 yd ³)	1380 mm (54.3")	1500 mm (59.1")	1110 kg (2450 lb)					
1.74 m ³ (2.28 yd ³)	1.5 m ³ (1.96 yd ³)	1620 mm (63.8")	1740 mm (68.5")	1230 kg (2710 lb)					
2.10 m ³ (2.75 yd ³)	1.8 m ³ (2.35 yd ³)	1910 mm (75.2")	2030 mm (79.9")	1370 kg (3020 lb)					

※ : Standard bucket

 Applicable for materials with density of 2000 kg/m³ (3370 lb/yd³) or less

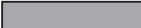
 Applicable for materials with density of 1600 kg/m³ (2700 lb/yd³) or less

 Applicable for materials with density of 1100 kg/m³ (1850 lb/yd³) or less

2) ROCK AND HEAVY DUTY BUCKET

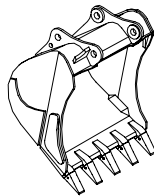
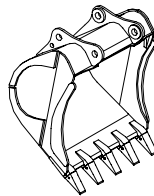
	
<p>◆ 1.44 m³ SAE heaped bucket</p>	<p>◎ 1.44 m³ SAE ◎ 1.73 m³ SAE heaped bucket</p>

Capacity		Width		Weight	Recommendation				
					6.45 m (21' 2") boom				6.15 m (20' 2") boom
SAE heaped	CECE heaped	Without side cutter	With side cutter		2.2 m arm (7' 3")	2.5 m arm (8' 2")	3.2 m arm (10' 6")	4.05 m arm (13' 3")	2.2 m arm (7' 3")
◆ 1.44 m ³ (1.88 yd ³)	1.25 m ³ (1.63 yd ³)	1470 mm (57.9")	-	1380 kg (3040 lb)					
◎ 1.44 m ³ (1.88 yd ³)	1.25 m ³ (1.63 yd ³)	1470 mm (57.9")	-	1470 kg (3240 lb)					
◎ 1.73 m ³ (2.26 yd ³)	1.5 m ³ (1.96 yd ³)	1710 mm (67.3")	-	1610 kg (3550 lb)					

◆ : Heavy duty bucket

◎ : Rock bucket (esco type)

Applicable for materials with density of 2000 kg/m³ (3370 lb/yd³) or less

Applicable for materials with density of 1600 kg/m³ (2700 lb/yd³) or less

7. UNDERCARRIAGE

1) TRACKS

X-leg type center frame is integrally welded with reinforced box-section track frames. The design includes dry tracks, lubricated rollers, idlers, sprockets, hydraulic track adjusters with shock absorbing springs and assembled track-type tractor shoes with triple grousers.

2) TYPES OF SHOES

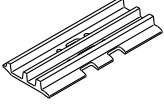
Model	Shapes		Triple grouser			
						
R320LC-9	Shoe width	mm (in)	600(24)	700(28)	800(32)	900(36)
	Operating weight	kg (lb)	32200(71000)	32800(72300)	33200(73200)	33600(74100)
	Ground pressure	kgf/cm ² (psi)	0.63(8.96)	0.54(7.68)	0.48(6.83)	0.43(6' 11")
	Overall width	mm (ft-in)	3280(10' 9")	3380(11' 1")	3480(11' 5")	3580(11' 9")
R320NLC-9	Shoe width	mm (in)	600(24)	-	-	-
	Operating weight	kg (lb)	32000(70500)	-	-	-
	Ground pressure	kgf/cm ² (psi)	0.61(8.67)	-	-	-
	Overall width	mm (ft-in)	2990(9' 10")	-	-	-
R320LC-9 HIGH WALKER	Shoe width	mm (in)	600(24)	700(28)	800(32)	Double Grouser 710(28)
	Operating weight	kg (lb)	34700(76500)	35300(77800)	35700(78700)	35900(79100)
	Ground pressure	kgf/cm ² (psi)	0.67(9.53)	0.58(8.25)	0.51(7.25)	0.58(8.25)
	Overall width	mm (ft-in)	3470(11' 5")	3570(11' 9")	3670(12' 0")	3580(11' 9")

3) NUMBER OF ROLLERS AND SHOES ON EACH SIDE

Item	Quantity
Carrier rollers	2EA
Track rollers	9EA
Track shoes	48EA

4) SELECTION OF TRACK SHOE

Suitable track shoes should be selected according to operating conditions.

Method of selecting shoes

Confirm the category from the list of applications in **table 2**, then use **table 1** to select the shoe. Wide shoes (categories B and C) have limitations on applications. Before using wide shoes, check the precautions, then investigate and study the operating conditions to confirm if these shoes are suitable.

Select the narrowest shoe possible to meet the required flotation and ground pressure. Application of wider shoes than recommendations will cause unexpected problem such as bending of shoes, crack of link, breakage of pin, loosening of shoe bolts and the other various problems.

※ **Table 1**

Track shoe	Specification	Category
600 mm triple grouser	Standard	A
700 mm triple grouser	Option	B
710 mm double grouser	Option	B
800 mm triple grouser	Option	C
900 mm triple grouser	Option	C

※ **Table 2**

Category	Applications	Applications
A	Rocky ground, river beds, normal soil	<ul style="list-style-type: none"> Travel at low speed on rough ground with large obstacles such as boulders or fallen trees
B	Normal soil, soft ground	<ul style="list-style-type: none"> These shoes cannot be used on rough ground with large obstacles such as boulders or fallen trees Travel at high speed only on flat ground Travel slowly at low speed if it is impossible to avoid going over obstacles
C	Extremely soft ground (swampy ground)	<ul style="list-style-type: none"> Use the shoes only in the conditions that the machine sinks and it is impossible to use the shoes of category A or B These shoes cannot be used on rough ground with large obstacles such as boulders or fallen trees Travel at high speed only on flat ground Travel slowly at low speed if it is impossible to avoid going over obstacles

8. SPECIFICATIONS FOR MAJOR COMPONENTS

1) ENGINE

Item	Specification
Model	Cummins QSC
Type	4-cycle turbocharged charger air cooled diesel engine
Cooling method	Water cooling
Number of cylinders and arrangement	6 cylinders, in-line
Firing order	1-5-3-6-2-4
Combustion chamber type	Direct injection type
Cylinder bore × stroke	114 × 135 mm (4.49" × 5.32")
Piston displacement	8300 cc (506 cu in)
Compression ratio	17.5 : 1
Rated gross horse power (SAE J1995)	278 Hp at 1750 rpm (207 kW at 1750 rpm)
Maximum torque	123.7 kgf · m (895 lbf · ft) at 1500 rpm
Engine oil quantity	35 l (9.2 U.S. gal)
Dry weight	723 kg (1594 lb)
High idling speed	1750+ 50 rpm
Low idling speed	700 ± 50 rpm
Rated fuel consumption	168.9 g/Hp · hr at 1750 rpm
Starting motor	Denso (24V-7.5 kW)
Alternator	Delco Remy 24V-50A
Battery	2 × 12V × 160Ah

2) MAIN PUMP

Item	Specification
Type	Variable displacement tandem axis piston pumps
Capacity	2 × 154 cc/rev
Rated oil flow	2 × 270 l/min (71.3 U.S. gpm / 59.4 U.K. gpm)
Rated speed	1750 rpm

3) GEAR PUMP

Item	Specification
Type	Fixed displacement gear pump single stage
Capacity	15cc/rev
Maximum pressure	40 kgf/cm ² (570 psi)
Rated oil flow	26.3 l /min (6.9 U.S. gpm/5.8 U.K. gpm)

4) MAIN CONTROL VALVE

Item	Specification
Type	9 spools
Operating method	Hydraulic pilot system
Main relief valve pressure	350 kgf/cm ² (4980 psi) [380 kgf/cm ² (5400 psi)]
Overload relief valve pressure	400 kgf/cm ² (5690 psi)

[]: Power boost

5) SWING MOTOR

Item	Specification
Type	Axial piston motor
Capacity	169.4 cc/rev
Relief pressure	300 kgf/cm ² (4270 psi)
Braking system	Automatic, spring applied hydraulic released
Braking torque	70 kgf · m (505 lbf · ft)
Brake release pressure	26 kgf/cm ² (370 psi)
Reduction gear type	2 - stage planetary

6) TRAVEL MOTOR

Item	Specification
Type	Variable displacement bent-axis axial piston motor
Relief pressure	350 kgf/cm ² (4980 psi)
Capacity (max / min)	154.8/88.5 cc/rev
Reduction gear type	3-stage planetary
Braking system	Automatic, spring applied hydraulic released
Brake release pressure	9 kgf/cm ² (128 psi)
Braking torque	40 kgf · m (290 lbf · ft)

7) REMOTE CONTROL VALVE

Item		Specification
Type		Pressure reducing type
Operating pressure	Minimum	6.5 kg/cm ² (92 psi)
	Maximum	26 kg/cm ² (370 psi)
Single operation stroke	Lever	61 mm (2.4 in)
	Pedal	123 mm (4.84 in)

8) CYLINDER

Item		Specification
Boom cylinder	Bore dia × Rod dia × Stroke	∅ 150 × ∅ 105 × 1480 mm
	Cushion	Extend only
Arm cylinder	Bore dia × Rod dia × Stroke	∅ 160 × ∅ 110 × 1685 mm
	Cushion	Extend and retract
Bucket cylinder	Bore dia × Rod dia × Stroke	∅ 140 × ∅ 100 × 1285 mm
	Cushion	Extend only

※ Discoloration of cylinder rod can occur when the friction reduction additive of lubrication oil spreads on the rod surface.

※ Discoloration does not cause any harmful effect on the cylinder performance.

9) SHOE

Item		Width	Ground pressure	Link quantity	Overall width
R320LC-9	Standard	☆600 mm (24")	0.62 kgf/cm ² (8.82 psi)	48	3280 mm (10' 9")
	Option	☆700 mm (28")	0.54 kgf/cm ² (7.68 psi)	48	3380 mm (11' 1")
		☆800 mm (32")	0.48 kgf/cm ² (6.83 psi)	48	3480 mm (11' 5")
		☆900 mm (36")	0.43 kgf/cm ² (6.11 psi)	48	3580 mm (11' 9")
R320NLC-9	Standard	☆600 mm (24")	0.61 kgf/cm ² (8.67 psi)	48	2990 mm (9' 10")
R320LC-9 H/WALKER	Standard	☆600 mm (24")	0.67 kgf/cm ² (9.53 psi)	48	3470 mm (11' 5")
	Option	☆700 mm (28")	0.58 kgf/cm ² (8.25 psi)	48	3570 mm (11' 9")
		☆800 mm (32")	0.51 kgf/cm ² (7.25 psi)	48	3670 mm (12' 0")
		★710 mm (28")	0.58 kgf/cm ² (8.25 psi)	48	3580 mm (11' 9")

☆ : Triple grouser

★ : Double grouser

10) BUCKET

Item		Capacity		Tooth quantity	Width		
		SAE heaped	CECE heaped		Without side cutter	With side cutter	
R320LC-9 R320NLC-9 H/WALKER	Standard	1.44 m ³ (1.88 yd ³)	1.25 m ³ (1.63 yd ³)	5	1380 mm (54.3")	1500 mm (59.1")	
	Option		0.9 m ³ (1.18 yd ³)	0.8 m ³ (1.05 yd ³)	3	950 mm (37.4")	1070 mm (42.1")
			1.14 m ³ (1.49 yd ³)	1.0 m ³ (1.31 yd ³)	4	1110 mm (43.7")	1230 mm (48.4")
			1.74 m ³ (2.28 yd ³)	1.5 m ³ (1.96 yd ³)	5	1620 mm (63.8")	1740 mm (68.5")
			2.10 m ³ (2.75 yd ³)	1.8 m ³ (2.35 yd ³)	5	1910 mm (75.2")	2030 mm (79.9")
		◆	1.44 m ³ (1.88 yd ³)	1.25 m ³ (1.63 yd ³)	5	1470 mm (57.9")	-
		◎	1.44 m ³ (1.88 yd ³)	1.25 m ³ (1.63 yd ³)	5	1470 mm (57.9")	-
		◎	1.73 m ³ (2.26 yd ³)	1.5 m ³ (1.96 yd ³)	5	1710 mm (67.3")	-

◆ : Heavy duty bucket

◎ : Rock bucket (esco type)

9. RECOMMENDED OILS

Use only oils listed below. Do not mix different brand oil.

Please use HYUNDAI genuine oil and grease.

Service point	Kind of fluid	Capacity ℓ (U.S. gal)	Ambient temperature °C (°F)							
			-50 (-58)	-30 (-22)	-20 (-4)	-10 (14)	0 (32)	10 (50)	20 (68)	30 (86)
Engine oil pan	Engine oil	35 (9.2)	★SAE 5W-40				SAE 30			
			SAE 10W				SAE 10W-30			
			SAE 15W-40							
Swing drive	Gear oil	6.0 (1.6)	★SAE 75W-90							
Final drive		8.0×2 (2.1×2)	SAE 80W-90							
Hydraulic tank	Hydraulic oil	Tank: 190 (50) System: 330 (87)	★ISO VG 15				ISO VG 32			
			ISO VG 46				ISO VG 68			
Fuel tank	Diesel fuel	500 (132)	★ASTM D975 NO.1				ASTM D975 NO.2			
Fitting (grease nipple)	Grease	As required	★NLGI NO.1				NLGI NO.2			
Radiator (reservoir tank)	Mixture of antifreeze and water	45 (12)	Ethylene glycol base permanent type (50 : 50)							
			★Ethylene glycol base permanent type (60 : 40)							

SAE : Society of Automotive Engineers

API : American Petroleum Institute

ISO : International Organization for Standardization

NLGI : National Lubricating Grease Institute

ASTM : American Society of Testing and Material

★ : Cold region

Russia, CIS, Mongolia