

## GROUP 8 TURNING JOINT

### 1. REMOVAL AND INSTALL

#### 1) REMOVAL

- (1) Lower the work equipment to the ground and stop the engine.
- (2) Operate the control levers and pedals several times to release the remaining pressure in the hydraulic piping.
- (3) Loosen the breather slowly to release the pressure inside the hydraulic tank.
  - ▲ Escaping fluid under pressure can penetrate the skin causing serious injury.
  - ※ When pipes and hoses are disconnected, the oil inside the piping will flow out, so catch it in oil pan.
- (4) Disconnect all hoses .
- (5) Sling the turning joint assembly (1) and remove the mounting bolt(2).
  - Weight : 54kg(119lb)
  - Tightening torque :  $12 \pm 1.3\text{kgf} \cdot \text{m}$   
( $88 \pm 9.4\text{lbf} \cdot \text{ft}$ )
- (6) Remove the turning joint assembly.
  - ※ When removing the turning joint, check that all the hoses have been disconnected.

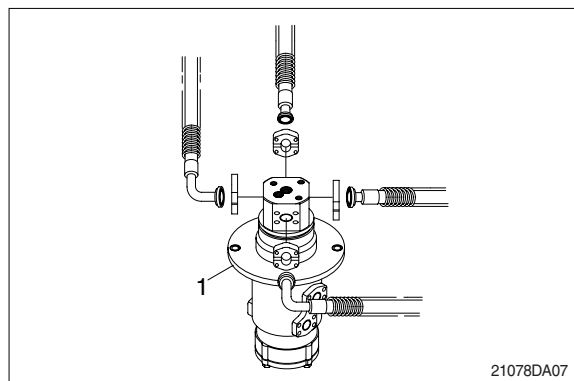

#### 2) INSTALL

- (1) Carry out installation in the reverse order to removal.
  - ※ Take care of turning joint direction.
  - ※ Assemble hoses to their original positions.
  - ※ Confirm the hydraulic oil level and check the hydraulic oil leak or not.

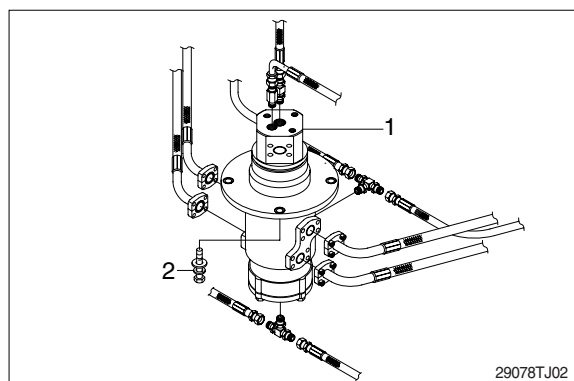

## 2. DISASSEMBLY AND ASSEMBLY

### 1) STRUCTURE

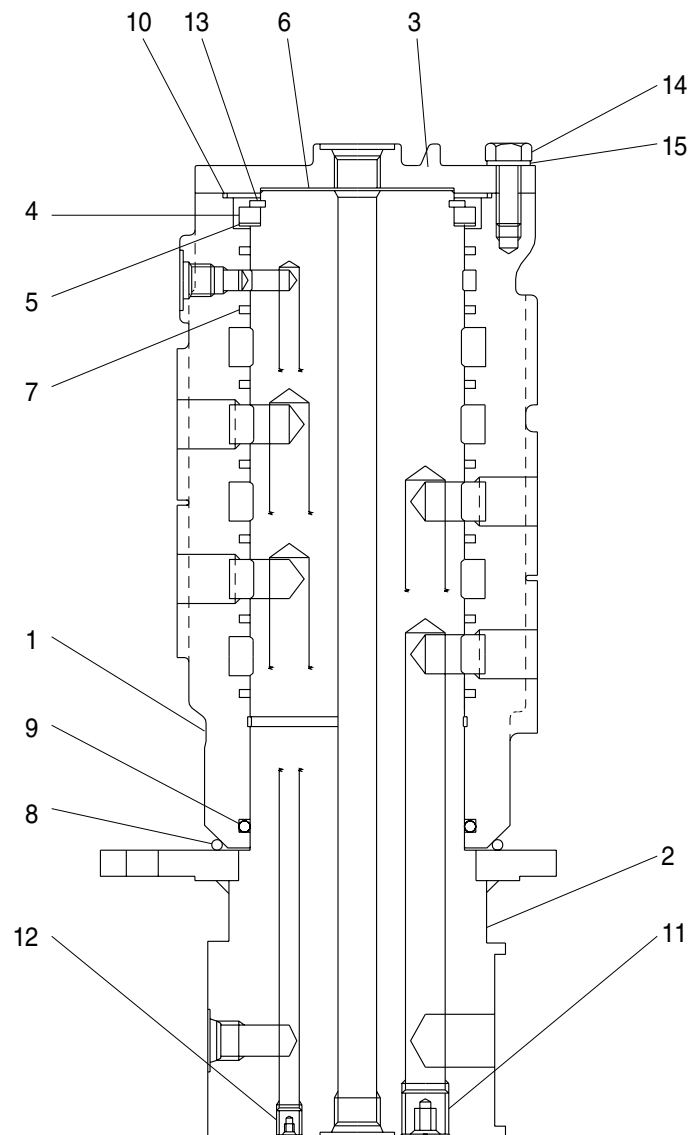

R210TJT2

- |   |                |    |              |    |               |
|---|----------------|----|--------------|----|---------------|
| 1 | Hub            | 6  | Shim         | 11 | Wear ring     |
| 2 | Shaft assembly | 7  | Slipper seal | 12 | Retainer ring |
| 3 | Cover          | 8  | O-ring       | 13 | Plug          |
| 4 | Spacer         | 9  | O-ring       | 14 | Hexagon bolt  |
| 5 | Shim           | 10 | O-ring       | 15 | Spring washer |

## 2) DISASSEMBLY

※ Before the disassembly, clean the turning joint.

(1) Remove bolts(14), washer(15) and cover(3).

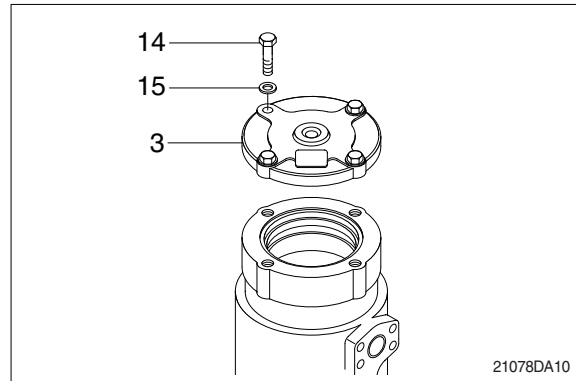

(2) Remove shim(6) and O-ring(10).

(3) Remove retainer ring(12), spacer(4) and shim(5).

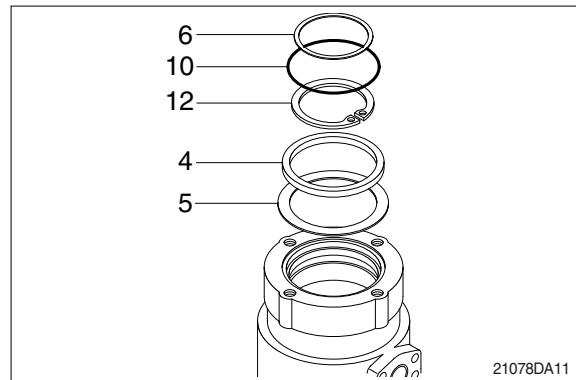

(4) Place body(1) on a V-block and by using a wood buffer at the shaft end, hit out shaft(2) to about 1/2 from the body with a hammer.

※ Take care not to damage the shaft(2) when remove body(1) or rest it sideways.

※ Put a fitting mark on body(1) and shaft(2).

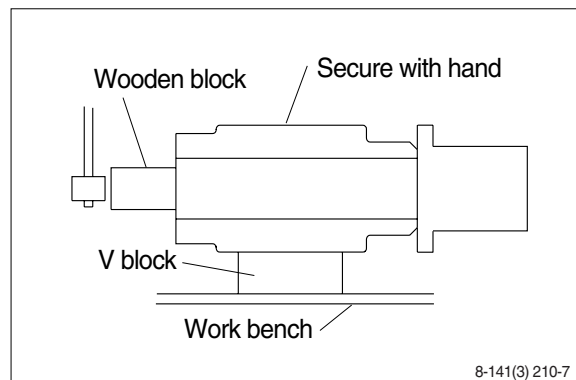

(5) Remove six slipper seals(7) and O-ring(9), two ring wear(11) from body(1).

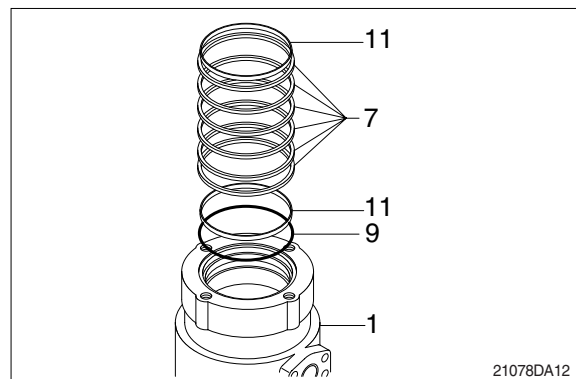

### 3) ASSEMBLY

- ※ Clean all parts.
- ※ As a general rule, replace oil seals and O-ring.
- ※ Coat the sliding surfaces of all parts with engine oil or grease before installing.

- (1) Fix seven slipper seal(7) and O-ring(9), two ring wear(11) to body(1).
- (2) Fit O-ring(8) to shaft(2).

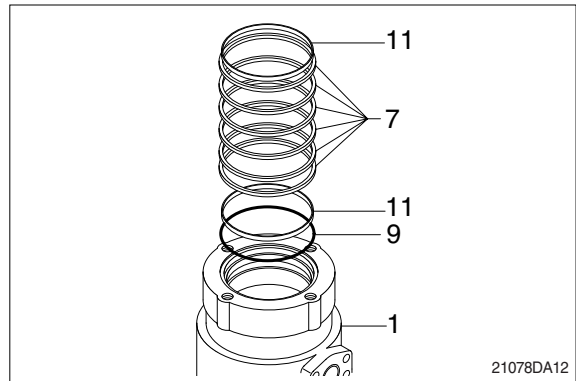

- (3) Set shaft(2) on block, tap body(1) with a plastic hammer to install.

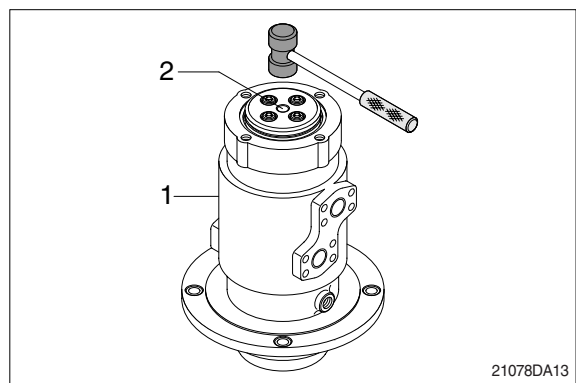

- (4) Fit shim(5), spacer(4) and retainer ring (12) to shaft(2).
- (5) Fit O-ring(10) to body(1).
- (6) Fit shim(6) to shaft(2).

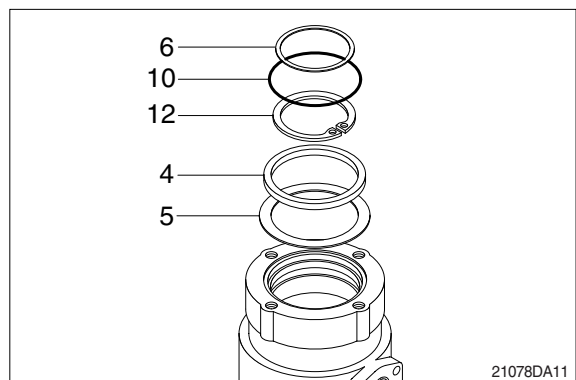

- (7) Install cover(3) to body(1) and tighten bolts(14).  
· Torque : 10~12.5kgf · m(72.3~90.4lbf · ft)

