

## GROUP 4 MAIN CONTROL VALVE

### 1. REMOVAL AND INSTALL

#### 1) REMOVAL

- (1) Lower the work equipment to the ground and stop the engine.
- (2) Operate the control levers and pedals several times to release the remaining pressure in the hydraulic piping.
- (3) Loosen the breather slowly to release the pressure inside the hydraulic tank.
- ▲ Escaping fluid under pressure can penetrate the skin causing serious injury.
- ※ When pipes and hoses are disconnected, the oil inside the piping will flow out, so catch it in oil pan.
- (4) Remove bolts and disconnect pipe.
- (5) Disconnect pilot line hoses.
- (6) Disconnect pilot piping.
- (7) Sling the control valve assembly and remove the control valve mounting bolt.
  - Weight : 200kg(425lb)
- (8) Remove the control valve assembly.  
When removing the control valve assembly, check that all the piping have been disconnected.

#### 2) INSTALL

- (1) Carry out installation in the reverse order to removal.
- (2) Bleed the air from below items.
  - ① Cylinder(Boom, arm, bucket)
  - ② Swing motor
  - ③ Travel motor
- ※ See each item removal and install.
- (3) Confirm the hydraulic oil level and recheck the hydraulic oil leak or not.

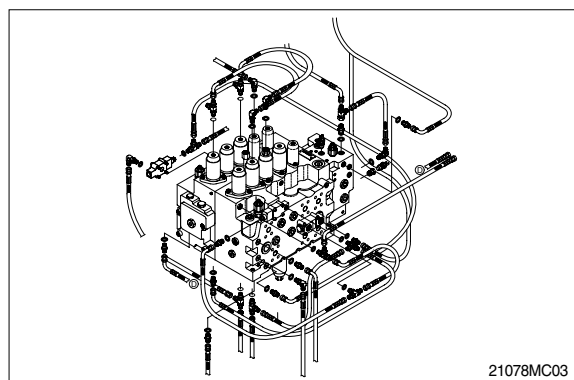
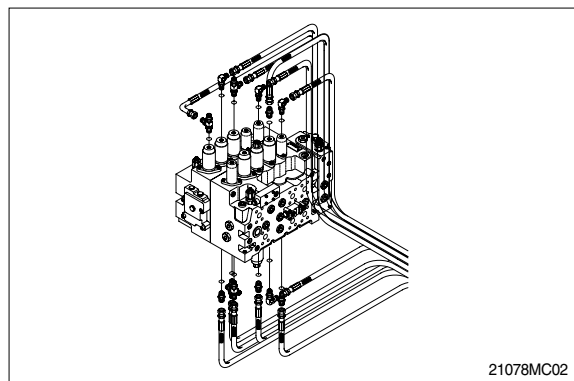
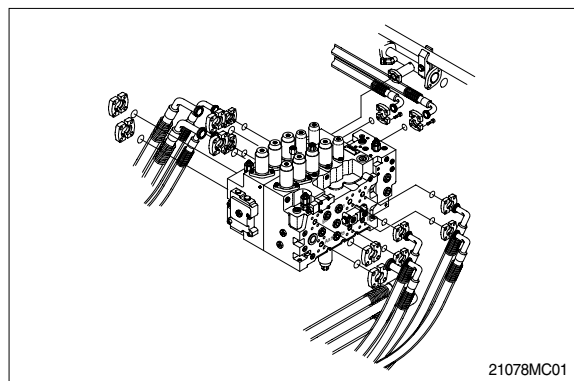

## 2. STRUCTURE(1/5)

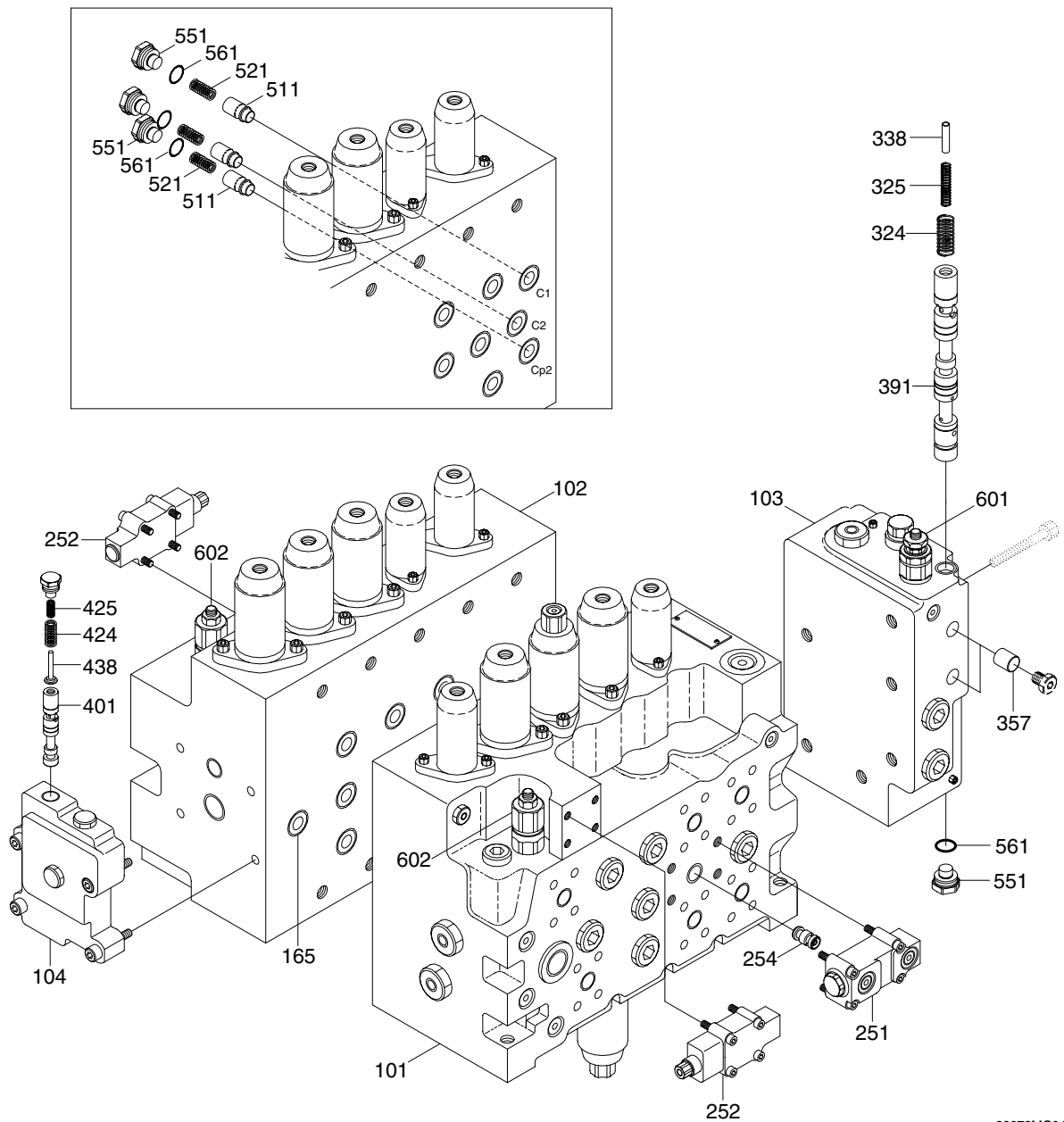

- |     |               |     |                  |     |                   |
|-----|---------------|-----|------------------|-----|-------------------|
| 101 | Casing A      | 324 | Spring           | 438 | Rod               |
| 102 | Casing B      | 325 | Spring           | 511 | Poppet            |
| 103 | Block         | 338 | Stopper          | 521 | Spring            |
| 104 | Block         | 357 | Orifice          | 551 | Plug              |
| 165 | O-ring        | 391 | Travel spool     | 561 | O-ring            |
| 251 | Control valve | 401 | Bypass cut spool | 601 | Main relief valve |
| 252 | Lock valve    | 424 | Spring           | 602 | Port relief valve |
| 254 | Logic valve   | 425 | Spring           |     |                   |

29078MC04

# STRUCTURE(2/5)

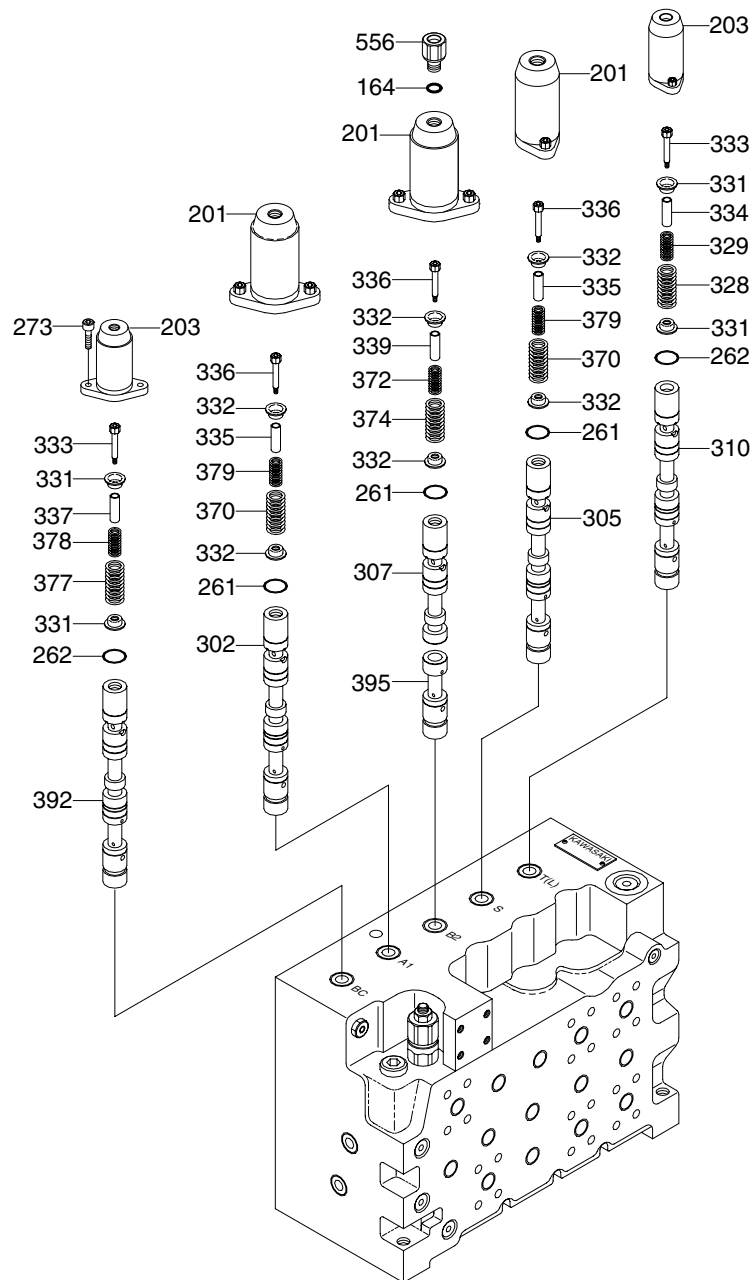

29078MC05

- |                     |             |                      |
|---------------------|-------------|----------------------|
| 164 O-ring          | 329 Spring  | 372 Spring           |
| 201 Cover           | 331 Seat    | 374 Spring           |
| 203 Cover           | 332 Seat    | 377 Spring           |
| 261 O-ring          | 333 Bolt    | 378 Spring           |
| 273 Socket screw    | 334 Stopper | 379 Spring           |
| 302 Arm 1 spool     | 335 Stopper | 392 Bypass cut spool |
| 305 Swing spool     | 336 Bolt    | 395 Priority spool   |
| 307 Boom 2 spool    | 337 Stopper | 556 Plug             |
| 310 Travel spool LH | 339 Stopper |                      |
| 328 Spring          | 370 Spring  |                      |



# STRUCTURE(4/5)

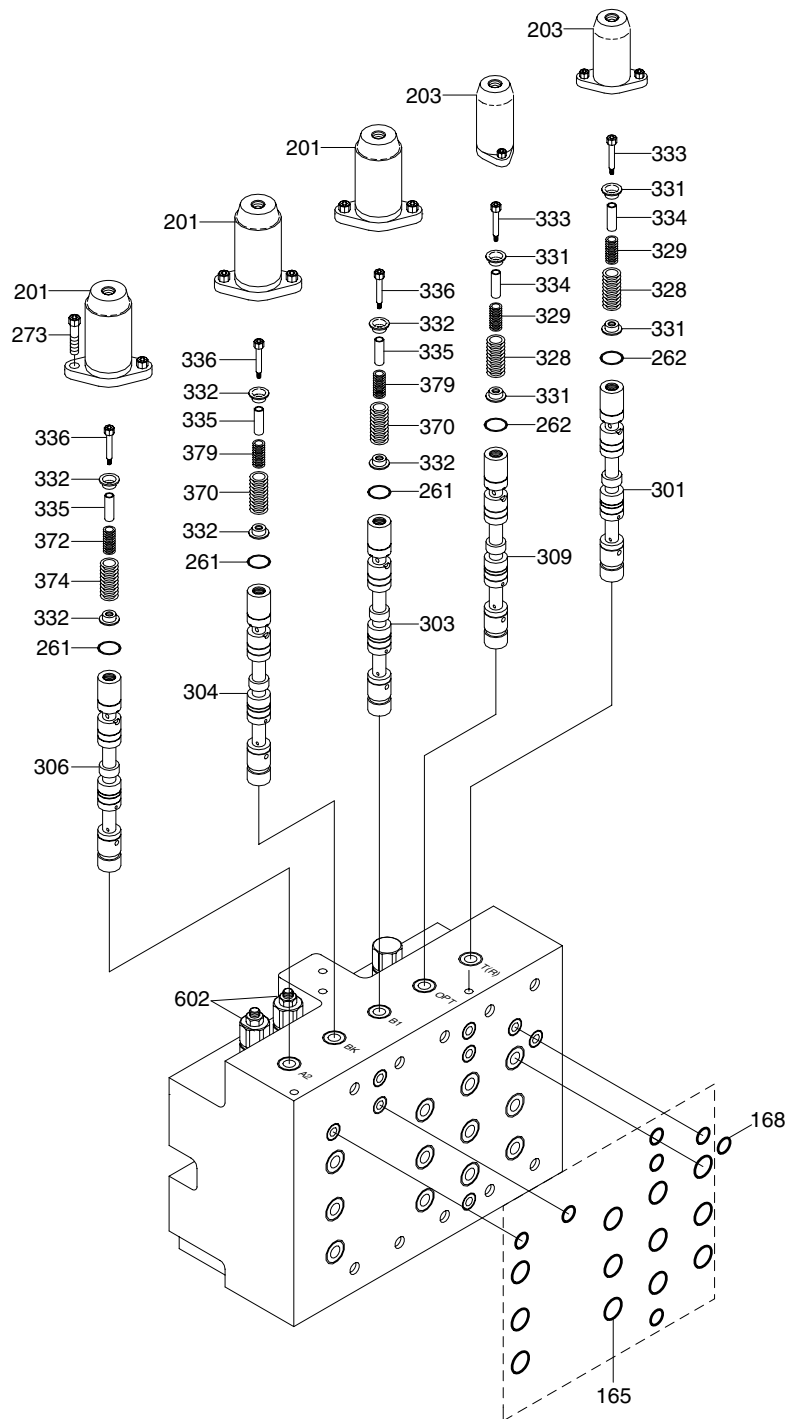

29078MC07

- |     |                 |     |                 |     |                   |
|-----|-----------------|-----|-----------------|-----|-------------------|
| 165 | O-ring          | 303 | Boom 1 spool    | 334 | Stopper           |
| 166 | O-ring          | 304 | Plug            | 335 | Stopper           |
| 168 | O-ring          | 306 | Arm 2 spool     | 336 | Bolt              |
| 201 | Cover           | 309 | Spool(Optional) | 370 | Spring            |
| 203 | Cover           | 328 | Spring          | 372 | Spring            |
| 261 | O-ring          | 329 | Spring          | 374 | Spring            |
| 262 | O-ring          | 331 | Seat            | 379 | Spring            |
| 273 | Socket screw    | 332 | Seat            | 602 | Port relief valve |
| 301 | Travel spool RH | 333 | Bolt            |     |                   |

# STRUCTURE(5/5)

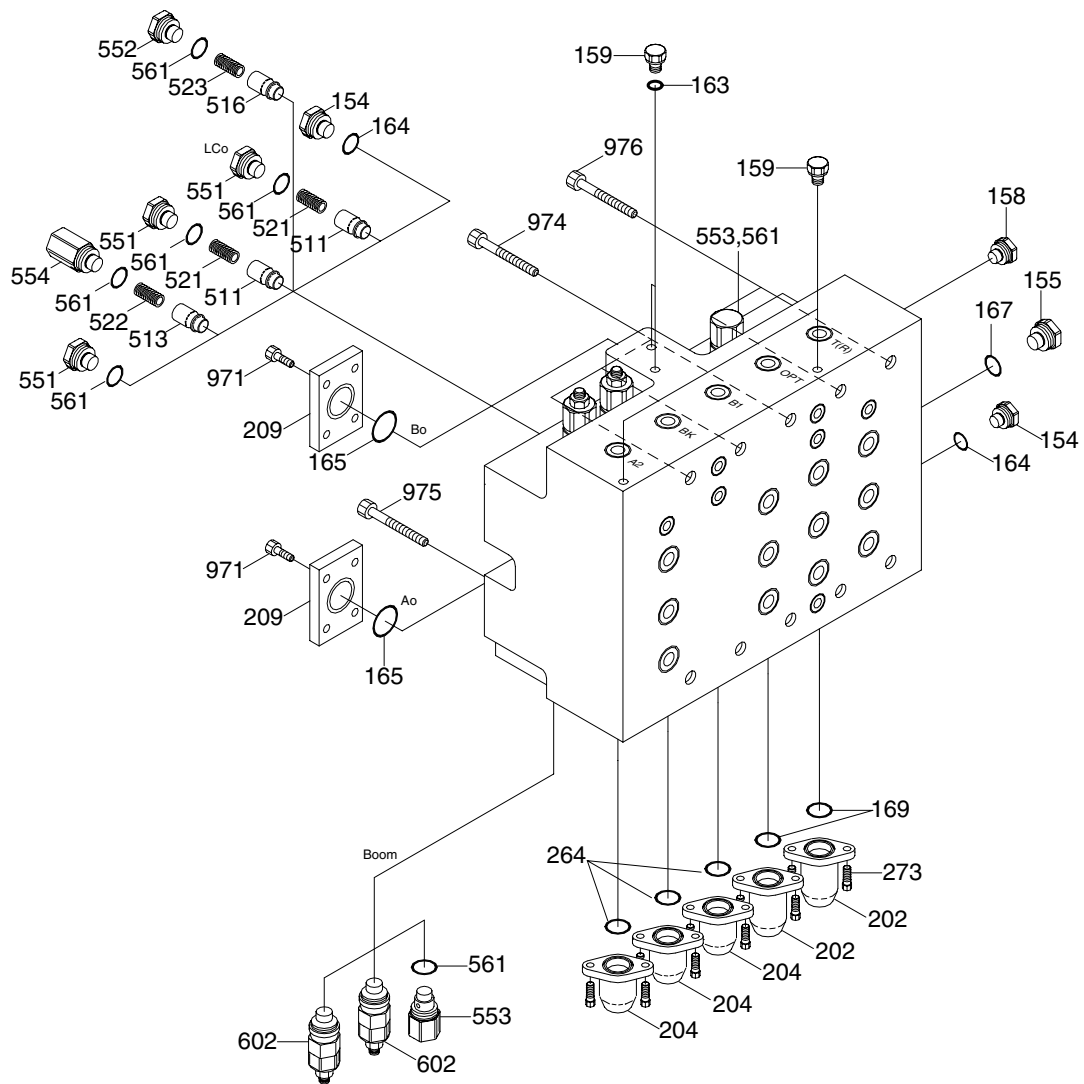

29078MC08

- |            |                  |                       |
|------------|------------------|-----------------------|
| 154 Plug   | 204 Cover        | 551 Plug              |
| 155 Plug   | 209 Flange       | 552 Plug              |
| 158 Plug   | 264 O-ring       | 553 Plug              |
| 159 Plug   | 273 Socket screw | 554 Plug              |
| 163 O-ring | 551 Poppet       | 561 O-ring            |
| 164 O-ring | 513 Poppet       | 602 Port relief valve |
| 165 O-ring | 516 Poppet       | 971 Screw             |
| 167 O-ring | 521 Spring       | 974 Screw             |
| 169 O-ring | 522 Spring       | 975 Screw             |
| 202 Cover  | 523 Spring       | 976 Screw             |

### 3. DISASSEMBLY AND ASSEMBLY

#### 1) GENERAL PRECAUTIONS

- (1) All hydraulic components are manufactured to a high precision. Consequently, before disassembling and assembling them, it is essential to select an especially clean place.
- (2) In handling a control valve, pay full attention to prevent dust, sand, etc. from entering into it.
- (3) When a control valve is to be removed from the machine, apply caps and masking seals to all ports. Before disassembling the valve, recheck that these caps and masking seals are fitted completely, and then clean the outside of the assembly. Use a proper bench for working. Spread paper or a rubber mat on the bench, and disassemble the valve on it.
- (4) Support the body section carefully when carrying or transferring the control valve. Do not lift by the exposed spool, end cover section etc.
- (5) After disassembling and assembling of the component it is desired to carry out various tests (For the relief characteristics, leakage, flow resistance, etc.), but hydraulic test equipment is necessary for these tests. Therefore, even when its disassembling can be carried out technically, do not disassemble such components that cannot be tested, adjusted, and so on. Additionally one should always prepare clean cleaning oil, hydraulic oil, grease, etc. beforehand.

#### 2) TOOLS

Before disassembling the control valve, prepare the following tools beforehand.

Name of tool	Quantity	Size(mm)
Vice mounted on bench(Soft jaws)	1 unit	-
Hexagon wrench	Each 1 piece	5, 6, 10, 12 and 14
Socket wrench	Each 1 piece	27 and 32
Spanner	Each 1 piece	32(Main relief valve)

### 3) DISASSEMBLY

The figure in ( ) shown after the part name in explanation sentence shows its number in the construction figures.

- (1) Place control valve on working bench.
  - ※ Disassemble the valve in a clean and dry environment and pay careful attention not to damage the sealing flange faces.

#### (2) Travel straight valve block

Loosen hexagon socket head bolts to and remove straight travel valve block(103) in its assembled state.

- Hexagon wrench : 14mm



21078MC09

#### (3) Main spool

- ① Loosen hexagon socket head bolts(273) and remove spring cover(201, 203).

- Hexagon wrench : 6mm



21078MC10

- ② Remove spool, springs, stopper, spring seats and spacer bolt in spool assembly condition from casing.

- ※ When extracting each spool assembly from its casing, pay attention not to damage the casing.



21078MC11



**(4) Covers**

Loosen hexagon socket head bolts(273) and then remove the spool cover(202, 204).

- Hexagon wrench : 6mm



21078MC12

**(5) Removal of port relief**

Remove port relief valves(602) from casing.

- Socket wrench : 32mm



21078MC13

**(6) Removal of plug (Option section)**

Remove plugs(553) from casing.

- Socket wrench : 27mm

**(7) Lock valve**

Loosen hexagon socket head bolts and remove lock valve(252).

- Hexagon wrench : 5mm



21078MC14

### (8) Negative control relief valve

- ① Remove plug(551).
  - Hexagon wrench : 12mm



21078MC15

- ② Remove poppet(611), spring(621) and damping rod(631).



21078MC16

### (9) Swing logic valve and check valve

- ① Loosen hexagon socket head bolts(251) and remove logic valve(251) and take check valve(254).
- ② Remove plug(551) or (552) and take out poppet(511) or (515, 516) and spring (521) or (523).
  - Hexagon wrench : 6, 12mm

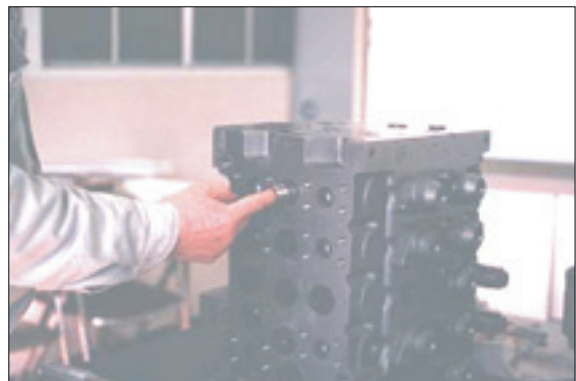

21078MC17

### (10) Boom priority valve

- Loosen hexagon socket head bolts(104) and remove boom priority valve(104).
  - Hexagon wrench : 10mm

### **(11) Inspection after disassembly**

Clean all disassembled parts with clean mineral oil fully, and dry them with compressed air. Then, place them on clean papers or cloths for inspection.

#### **① Control valve**

- a. Check whole surfaces of all parts for burrs, scratches, notches and other defects.
- b. Confirm that seal groove faces of casing and block are smooth and free of dust, dent, rust etc.
- c. Correct dents and damages and check seat faces within the casing, if any, by lapping.  
※ Pay careful attention not to leave any lapping agent within the casing.
- d. Confirm that all sliding and fitting parts can be moved manually and that all grooves and paths are free from foreign matter.
- e. If any spring is broken or deformed, replace it with new one.
- f. When a relief valve does not function properly, repair it, following the prescribed disassembly and assembly procedures.
- g. Replace all seals and O-rings with new ones.

#### **② Relief valve**

- a. Confirm that all seat faces at ends of all poppets and seats are free of defects and show uniform and consistent contact faces.
- b. Confirm manually that main poppet and seat can slide lightly and smoothly.
- c. Confirm that outside face of main poppet and inside face of seat are free from scratches and so on.
- d. Confirm that springs are free from breakage, deformation, and wear.
- e. Confirm that orifices of main poppet and seat section are not clogged with foreign matter.
- f. Replace all O-rings with new ones.
- g. When any light damage is found in above inspections, correct it by lapping.
- h. When any abnormal part is found, replace it with a completely new relief valve assembly.

## 4) ASSEMBLY

### (1) General comments

- ① In this assembly section, explanation only is shown.  
For further understanding, please refer to the figures and photographs shown in the previous disassembly section.
- ② Figure in ( ) shown after the part name in the explanation refers to the reference identity number shown on the construction figure shown in the spares section.
- ③ **Cautions in assembling seal**
  - a. Pay close attention to keeping all seals free from handling damage and inspect carefully for damage before using them.
  - b. Apply clean grease or hydraulic oil to the seal so as to ensure it is fully lubricated before assembly.
  - c. Do not stretch seals so much as to deform them permanently.
  - d. In fitting O-rings, pay close attention not to roll them into their final position in addition, a twisted O-ring cannot easily untwist itself naturally and could thereby cause inadequate sealing and thereby both internal and external oil leakage.
  - e. Tighten fitting bolts for all sections with a torque wrench adjusted to the respective tightening torque as shown on the cross section drawings of the spares section.

### (2) Check valve

- ① Assemble poppets(511, 515, 516) and spring(521, 523).
- ② Put O-rings(561) on to plugs(551, 552).
- ③ Tighten plugs(551, 552) to the specified torque.
  - Hexagon wrench : 12mm
  - Tightening torque : 23~27kgf · m(166~195lbf · ft)

### (3) Negative control relief valve

- ① Assemble the poppets, springs and damping rods(611 × 2) together into casing A(101).
- ② Put O-ring(561) on to plug(551) and tighten the latter to its specified torque.
  - Hexagon wrench : 12mm
  - Tightening torque : 23~27kgf · m(166~195lbf · ft)

### (4) Lock valve

- ① Put O-rings onto the casing.
- ② Tighten hexagon socket head bolts to their specified torques.
  - Hexagon wrench : 5mm
  - Tightening torque : 1~1.4kgf · m(7.23~10.12lbf · ft)

### (5) Assembly of main relief, port relief valves

- ① Install main relief valve(601), port relief valve(602) into the casing and tighten to the specified torque.

Components	Tools	Tightening torque	
		kgf · m	lbf · ft
Main relief valve	Spanner 32mm	7~8	50.6~57.8
Port relief valve	Socket wrench 32mm	7~8	50.6~57.8

## (6) Main spools

- ① Carefully insert the previously assembled spool assemblies into their respective bores within of casing A(101) and casing B(102).
- ※ Fit spool assemblies into casing A(101) and casing B(102) carefully and slowly. Do not under any circumstances push them forcibly in.

## (7) Covers

- ① Fit spool covers(202, 204) to the nonspring assembly end of the spool, and tighten the hexagonal socket head bolts(273) to the specified torque.
  - Hexagon wrench : 6mm
  - Tightening torque : 2.5~3.5kgf · m(18~25.3lbf · ft)
- ※ Confirm that O-rings(169, 264) have been fitted.
- ② Fit spring covers(201, 203) to the spring end for the spools, and tighten hexagon socket head bolts(273) to the specified torque.
  - Hexagon wrench : 6mm
  - Tightening torque : 2.5~3.5kgf · m(18~25.3lbf · ft)
- ※ Confirm that O-rings(261, 262) have been fitted.

## (8) Travel straight valve, swing logic valve and boom priority valve

- ① Put O-rings onto the casing.
- ② Tighten hexagon socket head bolts to their specified torques.

Components	Tools	Tightening torque	
		kgf · m	lbf · ft
Travel straight valve	Hexagon wrench 14mm	28~32	202~231
Swing logic valve	Hexagon wrench 6mm	2.5~3.5	18~25.3
Boom priority valve	Hexagon wrench 10mm	8.5~11.5	61.5~83.1