

GROUP 11 WORK EQUIPMENT

1. STRUCTURE

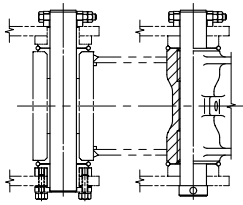

SECTION A

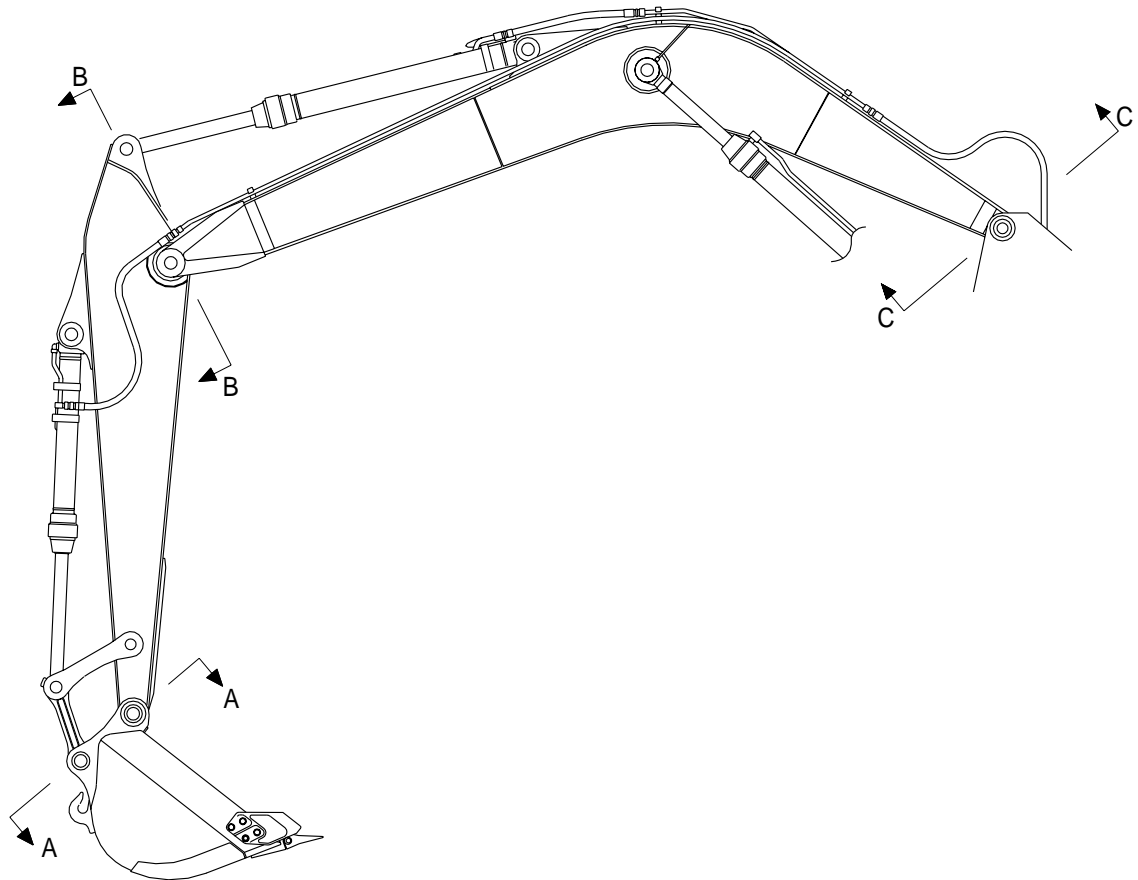
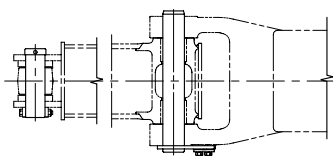

SECTION B

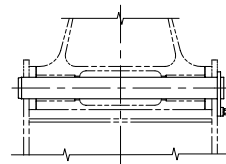

SECTION C

2. REMOVAL AND INSTALL

1) BUCKET ASSEMBLY

(1) Removal

- ① Lower the work equipment completely to ground with back of bucket facing down.

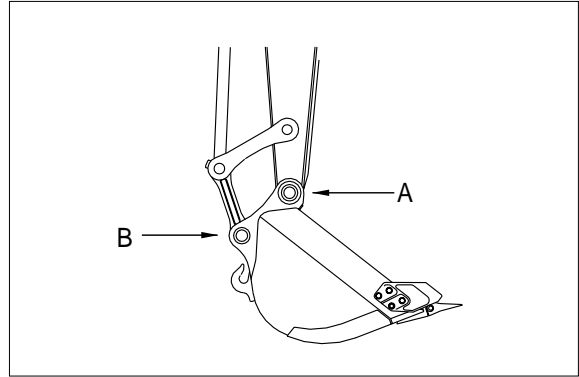

- ② Remove nut(1), bolt(2) and draw out the pin(A).

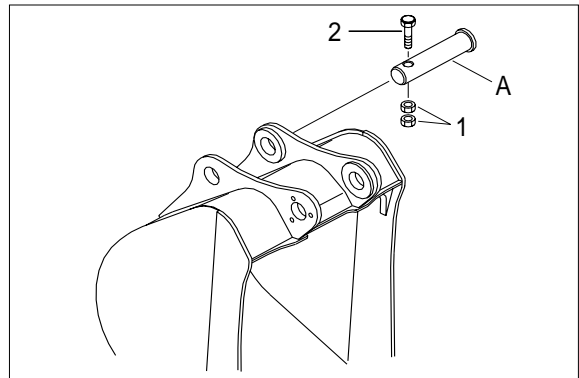

- ③ Remove nut(3), bolt(4) and draw out the pin(B).

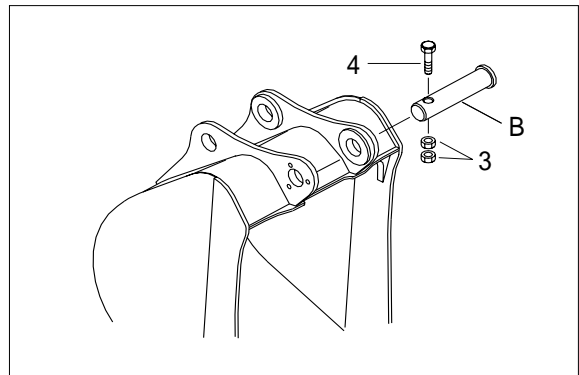

(2) Install

- ① Carry out installation in the reverse order to removal.
- ▲ When aligning the mounting position of the pin, do not insert your fingers in the pin hole.
 - ※ Adjust the bucket clearance.
For detail, see **operation manual**

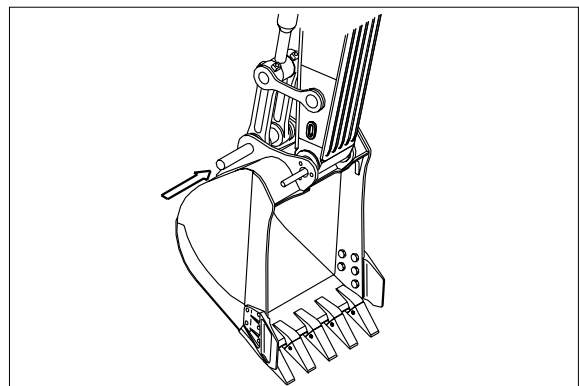

1) ARM ASSEMBLY

(1) Removal

※ Loosen the breather slowly to release the pressure inside the hydraulic tank.

▲ Escaping fluid under pressure can penetrate the skin causing serious injury.

① Remove bucket assembly.

For details, see **removal of bucket assembly**.

② Disconnect bucket cylinder hose(1).

▲ Fit blind plugs in the piping at the chassis end securely to prevent oil from spurting out when the engine is started.

③ Sling arm cylinder assembly, remove spring, pin stopper and pull out pin.

※ Tie the rod with wire to prevent it from coming out.

For details, see **removal of arm cylinder assembly**.

④ Place a wooden block under the cylinder and bring the cylinder down to it.

⑤ Remove bolt(2), plate(3) and pull out the pin(4) then remove the arm assembly.

· Weight : 1050kg(2320lb)

※ When lifting the arm assembly, always lift the center of gravity.

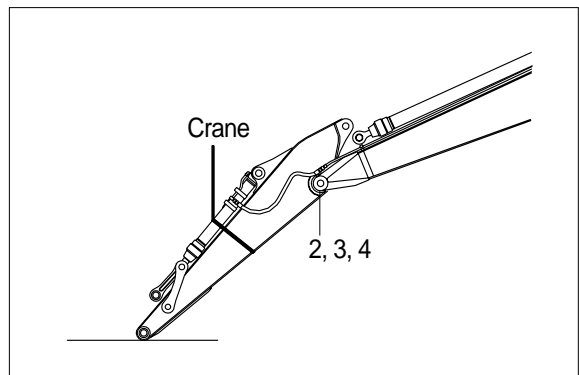
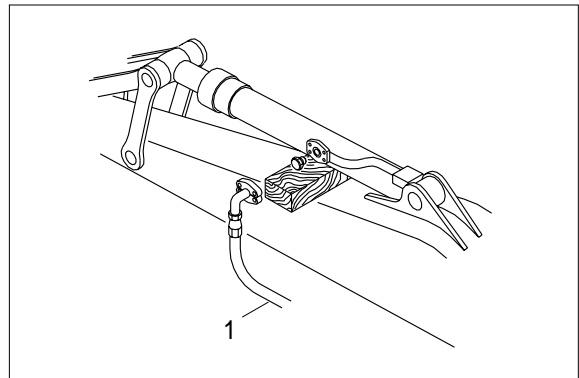
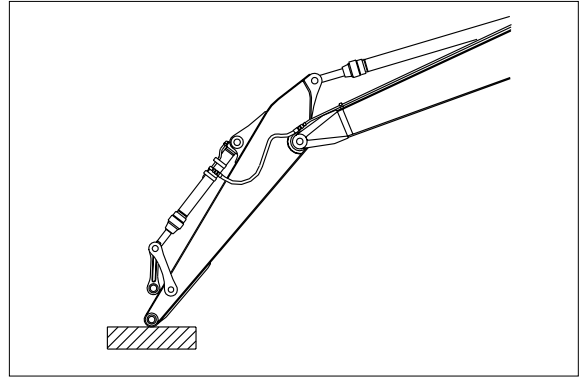

(2) Install

① Carry out installation in the reverse order to removal.

▲ When lifting the arm assembly, always lift the center of gravity.

※ Bleed the air from the cylinder.

3) BOOM CYLINDER

(1) Removal

- ① Remove arm and bucket assembly
For details, see **removal of arm and bucket assembly**.
- ② Remove boom cylinder assembly from boom.
For details, see **removal of arm cylinder assembly**.

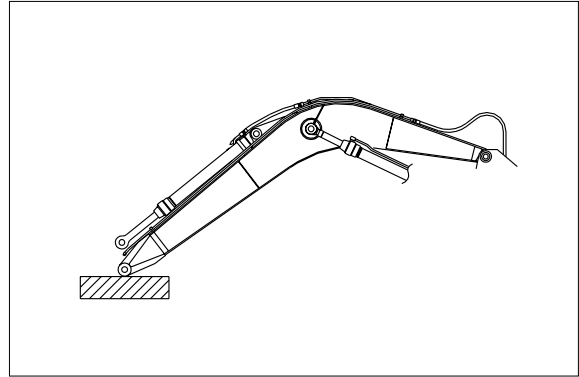

- ③ Disconnect head lamp wiring.
 - ④ Disconnect bucket cylinder hose(2) and arm cylinder hose(1).
- ※ When the hose are disconnected, oil may spurt out.
- ⑤ Sling boom assembly(3).

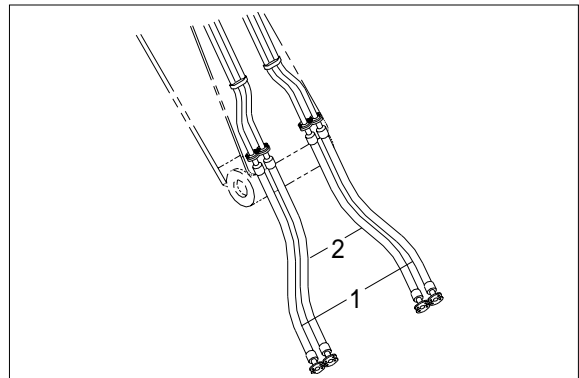

- ⑥ Remove bolt(4), plate(5) and pull out the pin(6) then remove boom assembly.
· Weight : 2350kg (5180lb)
- ※ When lifting the boom assembly always lift the center of gravity.

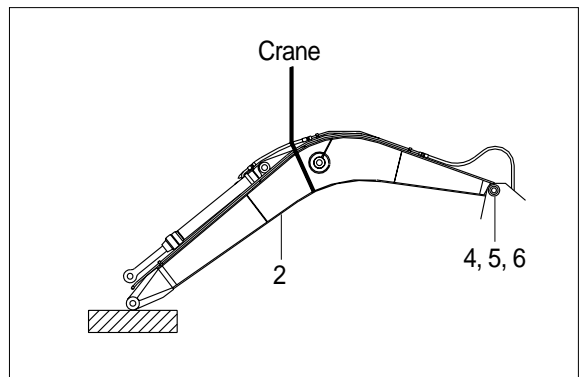

(2) Install

- ① Carry out in stallation in the reverse order to removal.
- ▲ When lifting the arm assembly, always lift the center of gravity.
- ※ Bleed the air from the cylinder.

