

GROUP 6 TRAVEL DEVICE

1. REMOVAL AND INSTALL

1) REMOVAL

- (1) Swing the work equipment 90° and lower it completely to the ground.
- (2) Loosen the breather slowly to release the pressure inside the hydraulic tank.
 - ▲ Escaping fluid under pressure can penetrate the skin causing serious injury.
 - ※ When pipes and hoses are disconnected, the oil inside the piping will flow out, so catch it in oil pan.
- (3) Remove the track shoe assembly.
For details, see **removal of track shoe assembly**
- (4) Remove the cover.
- (5) Remove the hose.
 - ※ Fit blind plugs to the disconnected hoses.
- (6) Remove the bolts and the sprocket.
- (7) Sling travel device assembly (1).
- (8) Remove the mounting bolts (2), then remove the travel device assembly.
 - Weight : 410kg(904lb)

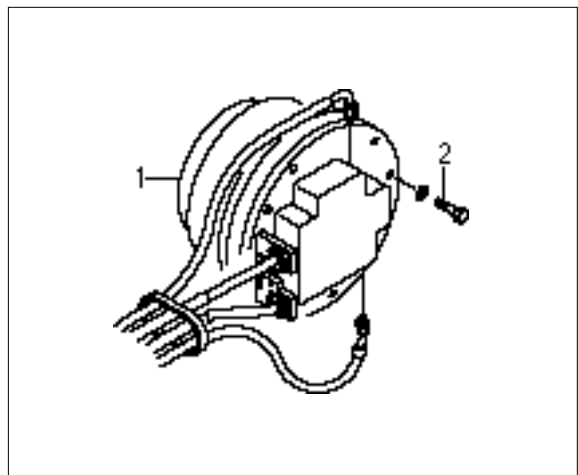

2) INSTALL

- (1) Carry out installation in the reverse order to removal
- (2) Bleed the air from the travel motor.
 - ① Remove the air vent plug.
 - ② Pour in hydraulic oil until it over flows from the port.
 - ③ Tighten plug lightly.
 - ④ Start the engine, run at low idling, and check oil come out from plug.
 - ⑤ Tighten plug fully.
- (3) Confirmed the hydraulic oil level and check the hydraulic oil leak or not.

2. TRAVEL MOTOR

1) STRUCTURE(1/2)

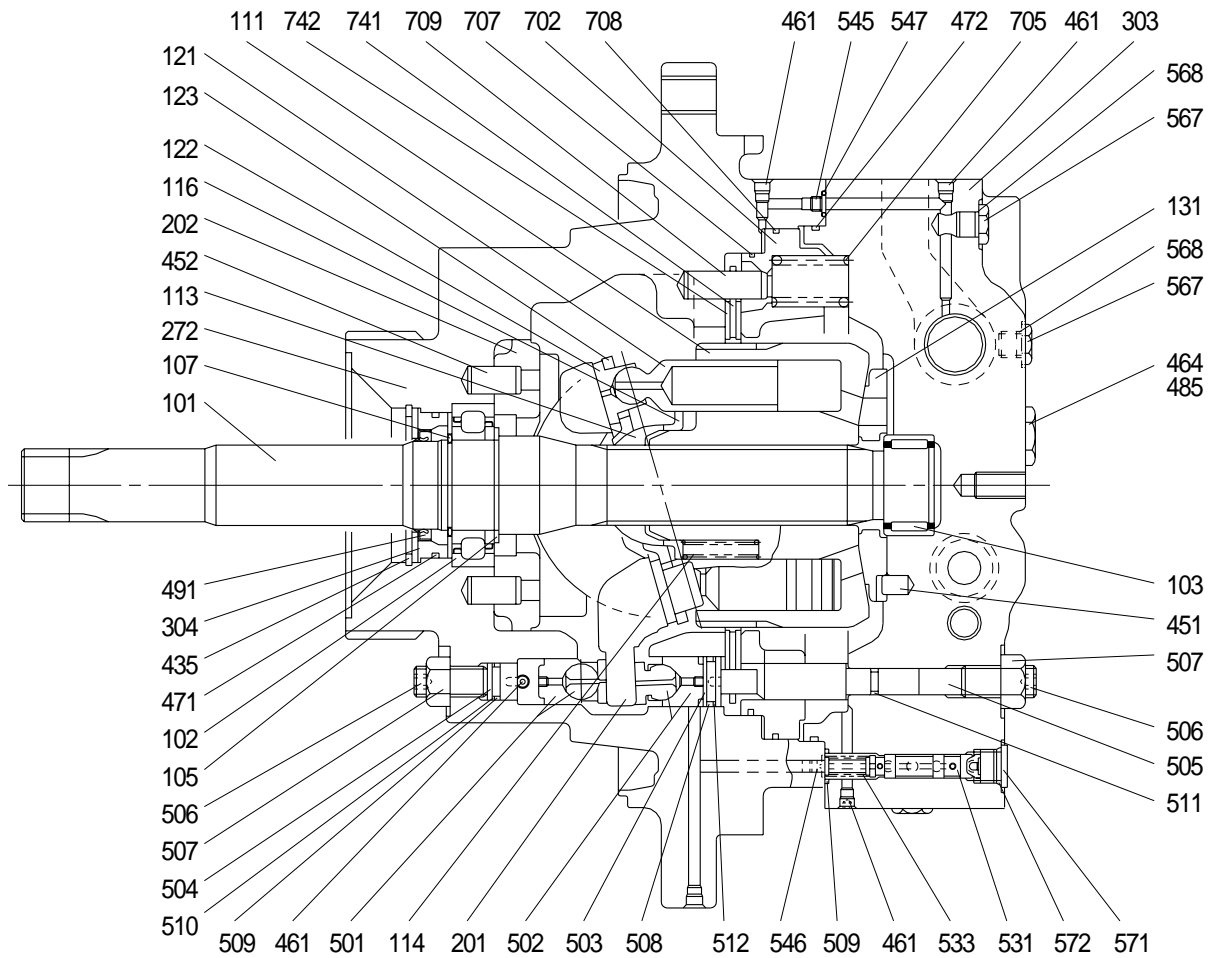

101	Drive shaft	304	Seal cover	510	Back up ring
102	Roller bearing	435	Snap ring	511	O-ring
103	Needle bearing	451	Pin 2	512	Back up ring
106	Bearing spacer	452	Pin 1	531	Tilting spool
107	Snap ring	461	Plug	533	Tilting spring
111	Cylinder block	471	O-ring	545	Orifice
113	Spherical bushing	472	O-ring	546	Orifice
114	Cylinder spring	491	Oil seal	547	O-ring
116	Spacer	501	Tilting piston	571	Plug
121	Piston	502	Tilting piston 1	572	O-ring
122	Shoe	503	Stopper	705	Brake piston
123	Set plate	504	Stopper S	707	Piston ring 252
131	Valve plate	505	Tilting rod	708	Piston ring 278
201	Swash plate	506	Hex socket screw	709	Center pin
202	Swash plate support	507	Nut	741	Separator plate
272	Casing A	508	O-ring	742	Friction plate
303	Valve casing	509	O-ring		

STRUCTURE(2/2)

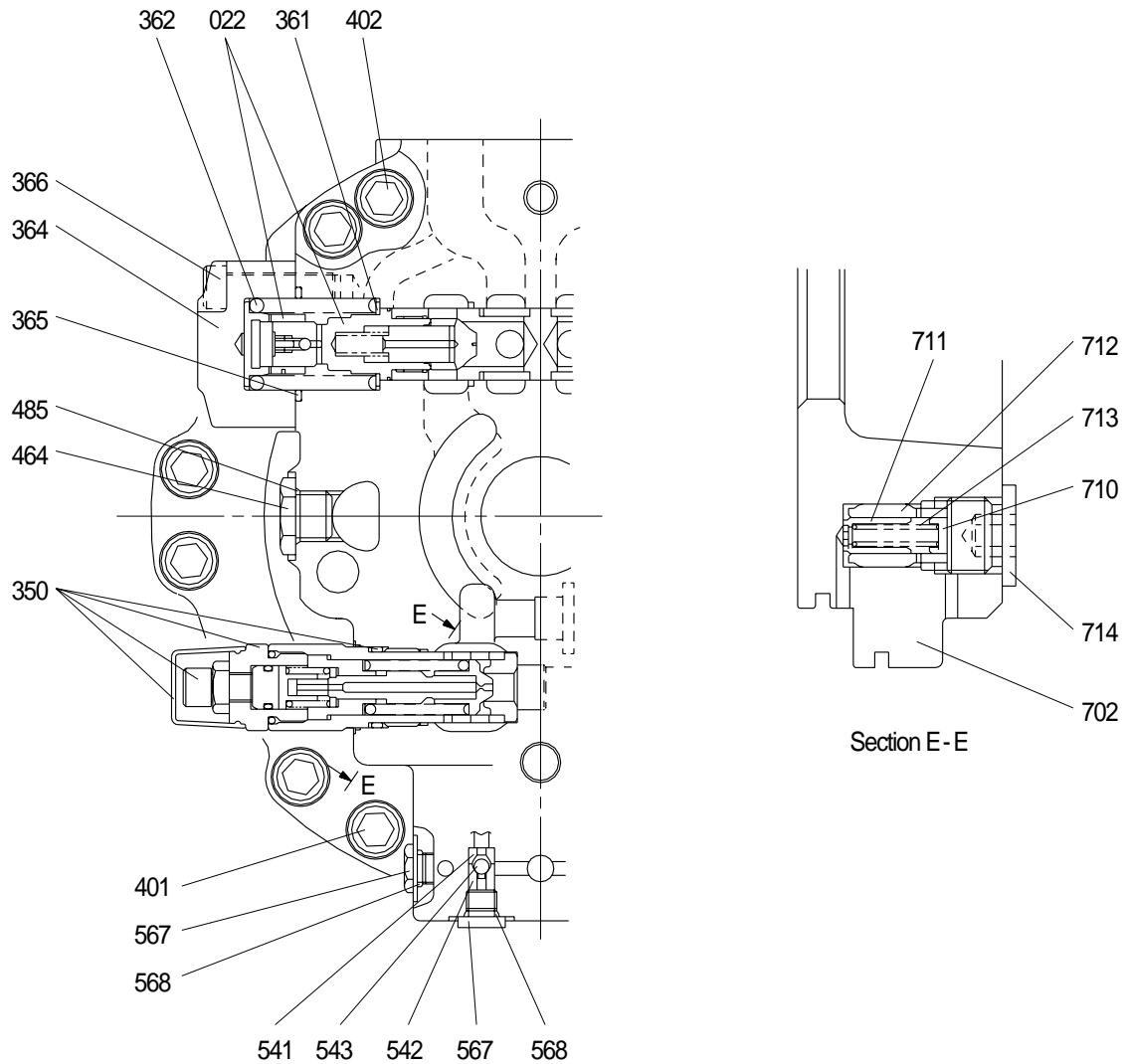

022 C/B Spool sub assy
 350 Relief valve
 361 Washer
 362 C/B spring
 364 C/B cover
 365 O - ring
 366 Hex socket screw
 401 Hex socket screw

402 Hex socket screw
 464 VP plug
 485 O - ring
 541 Seat
 542 Stopper
 543 Steel ball
 567 VP plug

568 O - ring
 702 Brake piston
 710 Spring guide
 711 Spool
 712 Bushing
 713 Spring
 714 RO plug

2) TOOLS AND TIGHTENING TORQUE

(1) Tools

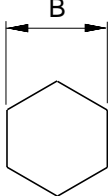
Tool name	Remark	
Allen wrench	4	
	6	
	8	
	10	
	14	
Socket for socket wrench, spanner	24	
	27	
Torque wrench	Capable of tightening with the specified torques.	
Pliers	-	
(-) Driver	6 × 100	
Plastic and iron hammer	Wooden hammer allowed. Nominal 1 or so	
Steel rod approx	7 × 7 × 200mm	
Monkey wrench	-	
Oil seal inserting jig	-	
Bearing pliers	-	
Seal tape	-	

(2) Tightening torque

Part name	Item	Size	Torque		Wrench size	
			kgf · m	lbf · ft	in	mm
Plug	461	NPTF 1/16	0.7~1.1	5.1~8.0	0.16	4
Socket head bolt	366	M 12 × 45	10	72.3	0.39	10
VP Plug	464	PF 1/2	11	79.6	1.06	27
Plug	571	PF 3/8	7.5	54.2	0.31	8
Orifice	545, 546	NPTF 1/16	0.7	5.1	0.16	4
Socket head screw	401	M 16 × 50	24	173.6	0.55	14
RO Plug	567	PF 1/4	3.7	26.8	0.24	6
Socket head screw	402	M16 × 120	24	173.6	0.55	14
Hexagon nut	507	M 16	16	115.7	0.94	24
RO plug	714	PF 3/8	7.5	54.2	0.31	8

3. TRAVEL REDUCTION GEAR

1) STRUCTURE

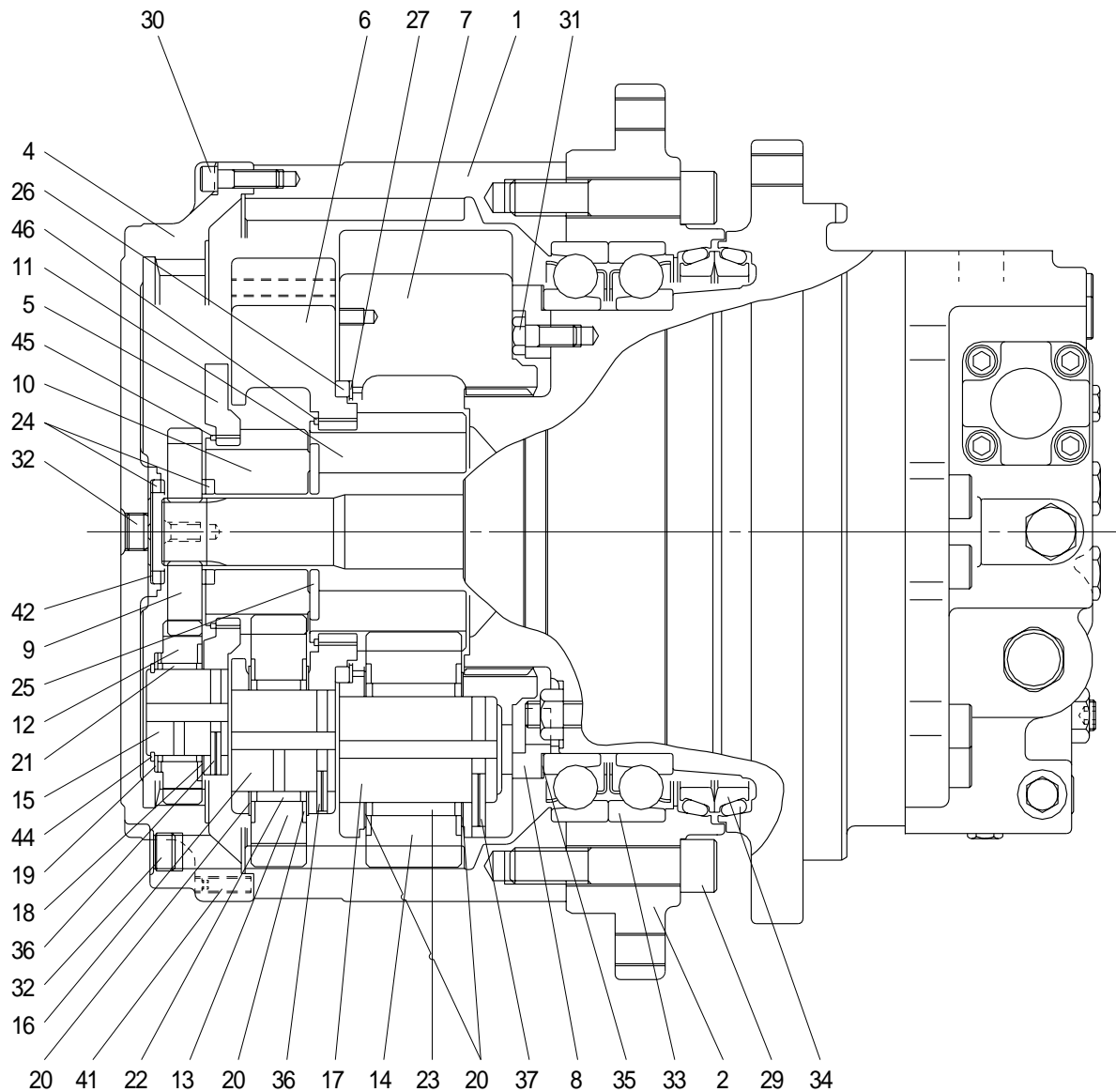

1	Ring gear	16	Pin 2	31	Hex screw
2	Housing	17	Pin 3	32	Plug
4	Side cover	18	Side plate	33	Angular bearing
5	Carrier 1	19	Side plate	34	Floating seal
6	Carrier 2	20	Side plate	35	Shim
7	Carrier 3	21	Needle case	36	Spring pin
8	Bearing retainer	22	Needle case	37	Spring pin
9	Sun gear 1	23	Needle case	41	Set screw
10	Sun gear 2	24	Thrust ring	42	Shim
11	Sun gear 3	25	Thrust ring	44	Snap ring
12	Planetary gear 1	26	Thrust ring	45	Clip
13	Planetary gear 2	27	Shim	46	W clip
14	Planetary gear 3	29	Hex socket screw		
15	Pin 1	30	Hex socket screw		

2) TOOLS AND TIGHTENING TORQUE

(1) Tools

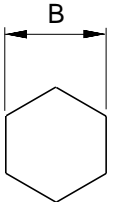
Tool name	Remark	
Allen wrench	5	
	8	
	10	
	17	
Socket for socket wrench	19	
Spanner	27	
Torque wrench	Capable of tightening with the specified torques.	
Pliers	For shaft	
(-) Driver	6 × 100, For removing floating seal	
Hammer	Steel and plastic	
Eye bolt	M10, M20, For lifting-up	
Press(1 ton)	-	
Depth gauge straight edge	100mm depth	
Taps	M 20, M 12	
Oil stone	-	
Seal tape	-	
Screw lock	Three bond 1303B	
Liquid packing	Three bond 1104	
Bearing assembling jig	-	

(2) Tightening torque

Part name	Item	Size	Torque		Wrench size	
			kgf · m	lbf · ft	in	mm
Socket head screw	29	M 20 × 100	55	397.8	0.67	17
	30	M10 × 35	6.7	48.5	0.31	8
	41	M10 × 30	To the extent their bottom is touched.		0.20	5
Hexagon head bolt	31	M12 × 30	11.5	83.2	0.75	19

4. DISASSEMBLING

1) GENERAL PRECAUTIONS

- (1) Pay attention to not damaging contact surfaces for O-ring, oil seals, etc. and contact/sliding surfaces for gears, pins, bearings, etc.
- (2) This motor can be disassembled even in a state fitted on a machine.
However, in that case, pay full attention to preventing mud, dust, etc. from entering in it.
- (3) The numeral in parentheses following each part name indicates its part number shown in the attached **assembly drawings**.
- (4) The piping side of the motor is referred to as the rear side and the output side, as the front side.

2) DISASSEMBLY OF REDUCTION GEAR

- (1) Select a disassembling place.
 - ※ Select a clean place.
 - ※ Spread rubber sheet or cloth on work bench to prevent parts from being damaged.
- (2) Remove dust, mud, etc. from reduction gear surfaces with washing oil or so.
- (3) Place reduction gear with its gear oil drain port or level gage at the lowest position, and drain reduction gear of oil.
 - ※ Receive gear oil with clean vessel and check it for abnormalities.
 - ※ Renew gear oil.

- (4) Place reduction gear with its side cover (004) up, remove hexagon socket head cap screws(030), and remove cover.

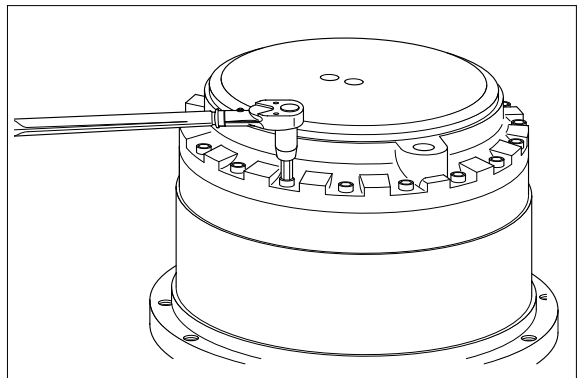

- ※ Screw hexagon socket headless set screws(041) to lift side cover from ring gear(001), and it can be removed easily.
- ※ Screw M10 screws into removing rapped hole and bring up cover.

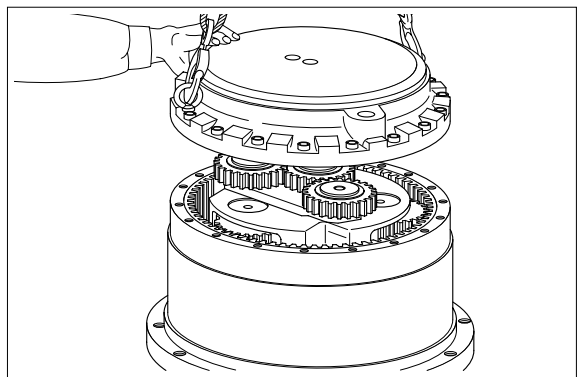

(5) Remove sun gear 1(9).

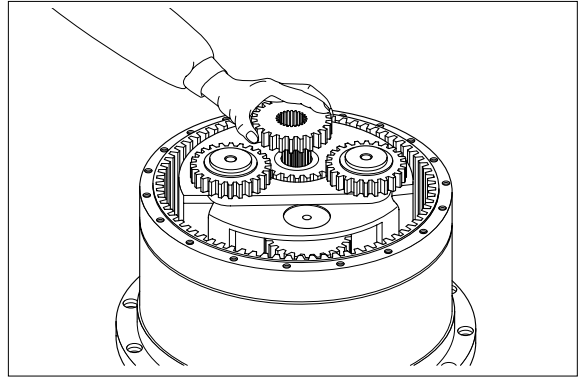

(6) Remove carrier 1(5) together with planetary gears 1(12), sun gear 2(10), etc. fitted.

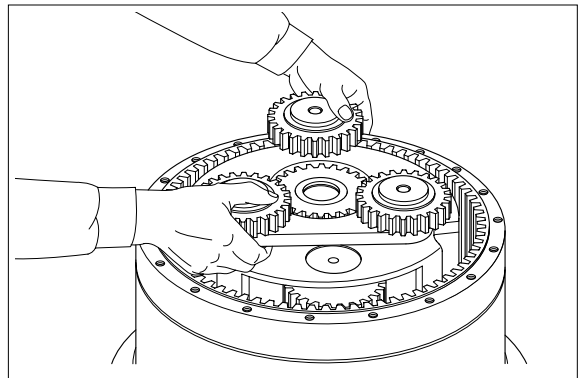

(7) Disassembling of carrier 1 sub-assembly

① Remove retaining ring(44), and then remove side plate(19), planetary gear 1 (12), needle bearing(21), and side plate(18).

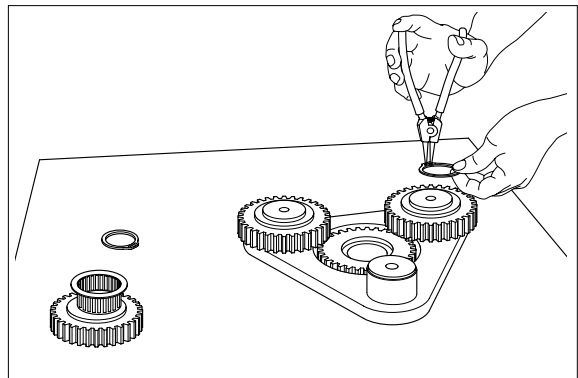

② Remove circlip(45), and then remove carrier 1(5) from sun gear 2(10).

③ Remove thrust ring(24).

※ If flaking is observed on the surface of pin 1, replace pin 1/carrier 1 as a set. In this case, replace planetary gear 1 and needle bearing simultaneously.

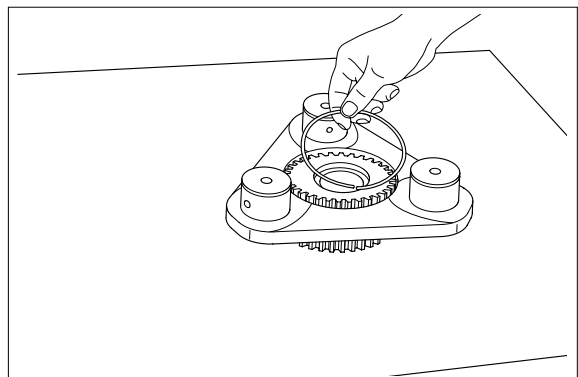

- (8) Remove carrier 2(6), with planetary gears 2(13), sun gear 3(11), etc. fitted.
Use M10 eyebolt. In this case, thrust ring(26) is removed simultaneously.

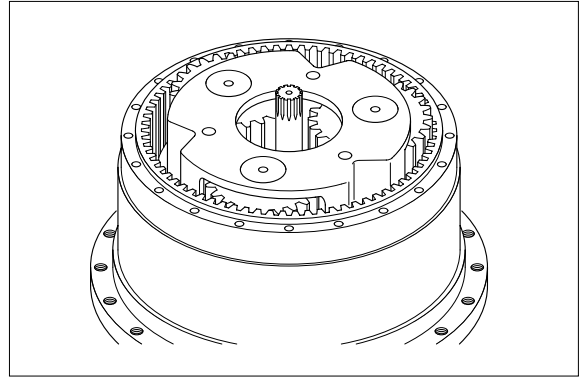

(9) Disassembling of carrier 2 sub-assembly

- ① Push in spring pin(36), and remove pin 2(16), from carrier 2.
 - ② Remove side plate(20), planetary gear 2(13), and needle bearing(22) from carrier 2.
 - ③ Remove thrust ring(26).
 - ④ Remove retaining ring(46), and remove carrier 2(6) from sun gear 3(11).
- ※ Carry out the following check in advance.
If any abnormality should be found, carry out disassembling.
- Is there any crevice, crack or pitting on tooth surface of planetary gear?
 - When turning planetary gear lightly, is there any abnormal noise or eccentric clearance?
- Carry out check similarly to the above for carrier 3.

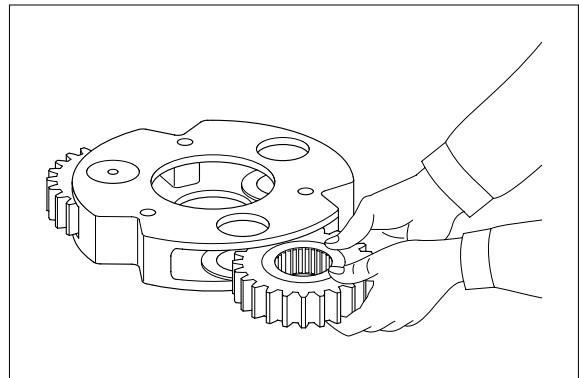

- ⑤ Remove thrust ring(25) from sun gear 3.

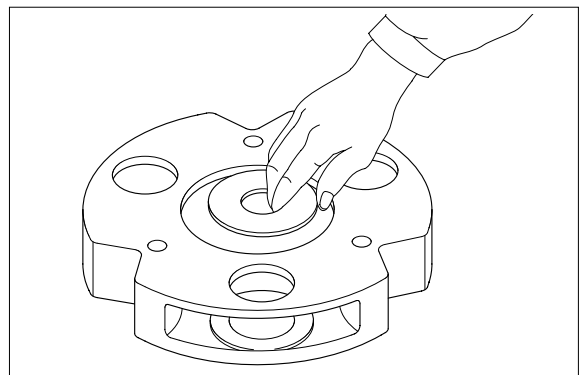

(14) Screw two M10 eyebolts on front side of ring gear(1), lift up ring gear, housing(2), angular bearing(33) and floating seal(34) from casing(272).

※ When it is difficult to separate them, hung the whole a little above bench and hit end face of casing slightly with plastic hammer or so to separate them.

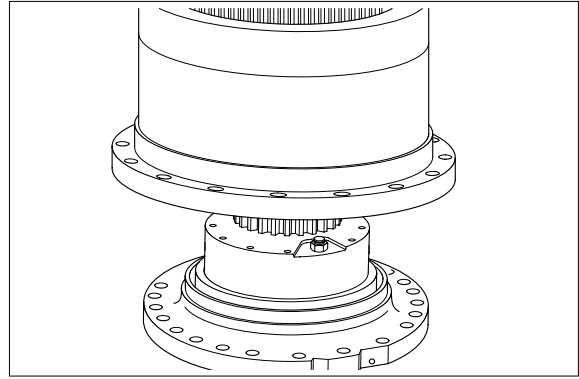

(15) Place ring gear(1) with its front part down.

※ Pay attention O-ring and sheet faces.

(16) Remove floating seal(34) from housing (2), paying attention to not damaging it.

※ Pay attention to O-ring and sheet races.

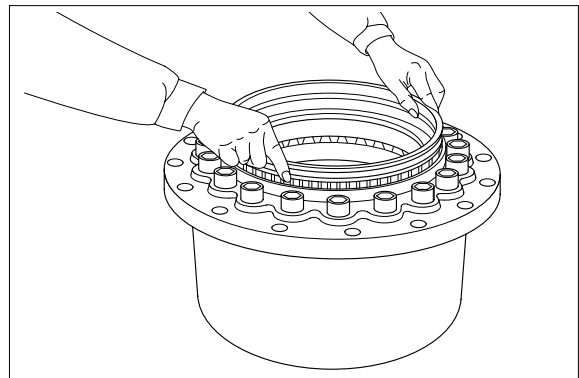

(17) Remove floating seal(34) from casing (272), pay attention to not damaging it.

※ Pay attention to O-ring and sheet faces.

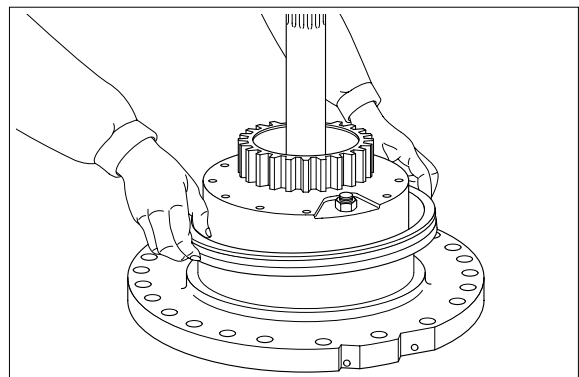

(18) Loosen hexagon socket head cap screws(29) that connect ring gear(1) and housing(2).

※ In this case, in order to prevent ring gear from turning, screw bolt to front side and lock it to the work bench.

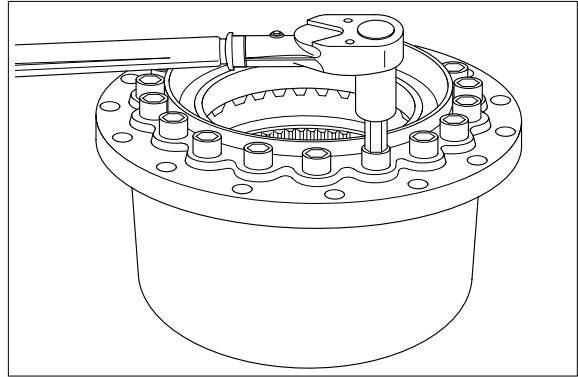

(19) Lift up housing(2) with crane with its ring gear(1) up, and hit upper face of housing with steel bar and hammer to separate them.

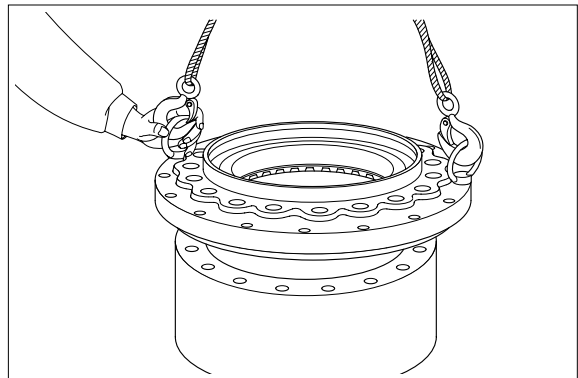

(20) Remove angular bearing(33) from housing(2).

※ Bearing should be removed once it is removed.

Remove bearing inner race by pushing it with press or by hitting it with hammer, utilizing jig.

3) DISASSEMBLY OF MOTOR

(1) Disassembling of motor main body

Place hydraulic motor on bench with its output shaft up.

Don't touch hexagon nut(507) and hexagon socket headless set screw (506) with hand, since this may change adjusted flow valve.

- ① Remove locking nut(435) with pliers.

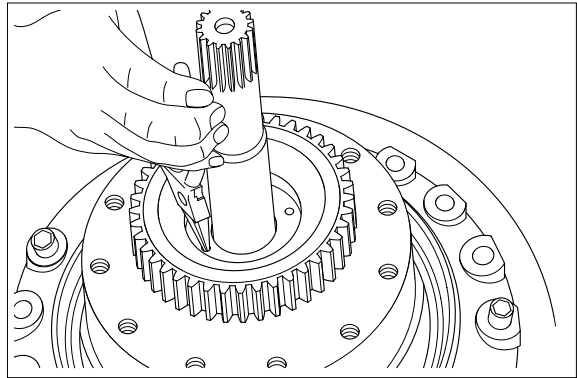

- ② Screw M4 to seal cover(304) and remove it.
- ③ Fix hydraulic motor with its output shaft down.

- ④ Loosen relief valve, plug, etc. that are fitted to valve casing(303).

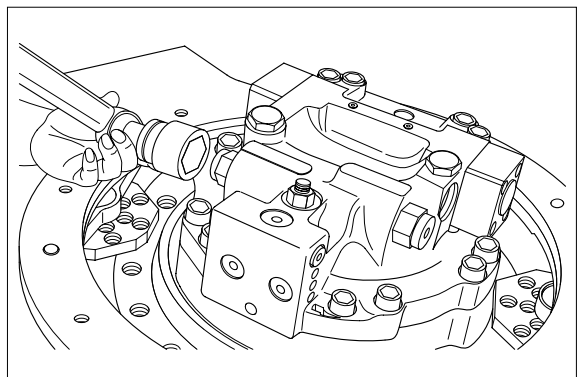

- ⑤ Loosen hexagon socket head bolts(401, 402) that assemble valve casing(303).

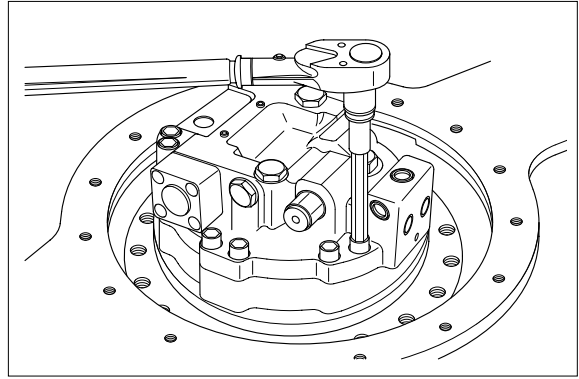

- ⑥ Remove the above hexagon socket head cap screws, and then separate valve casing sub-assembly and remove valve plate(131).

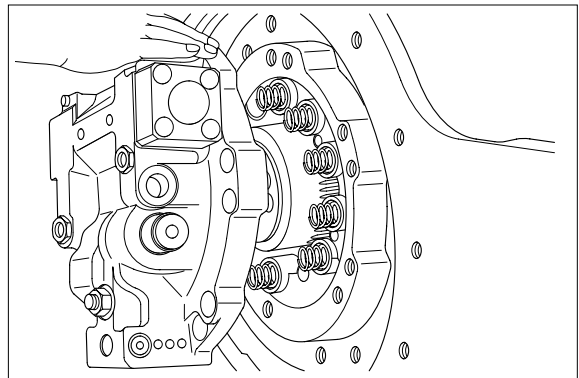

- ⑦ Remove brake springs(705), screw M16 bolt to brake piston(702), and remove it.
※ Ten pieces of brake springs are provided.

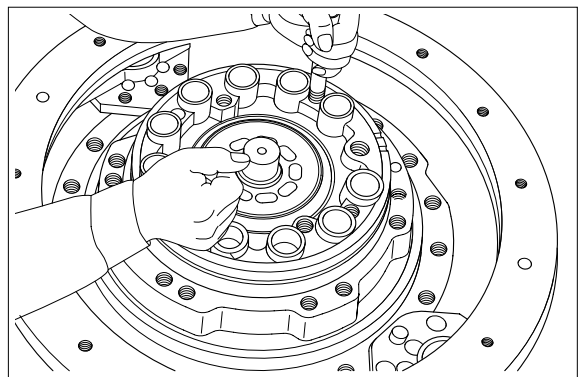
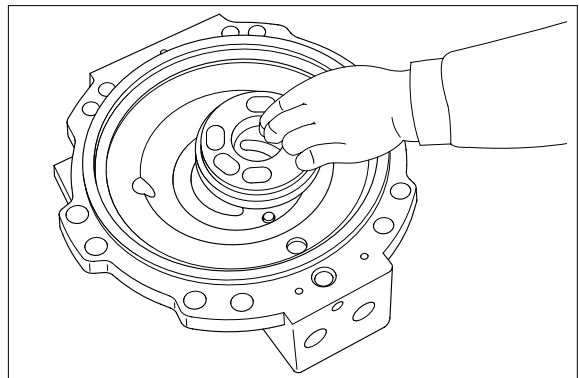

- ⑧ Pull out cylinder and piston sub-assembly.
※ For easy operation, place motor in horizontal position.

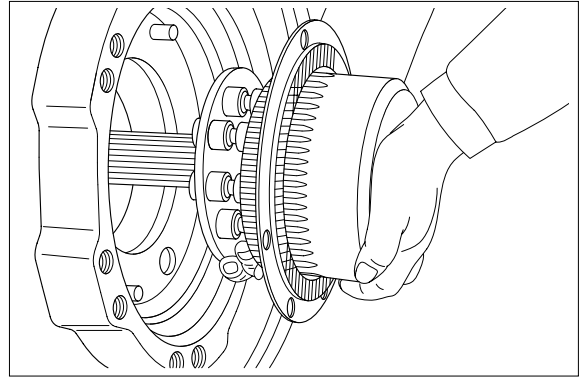

- ⑨ Remove stopper L(503) and piston(501).
※ Use M5 bolt and they can be removed easily.

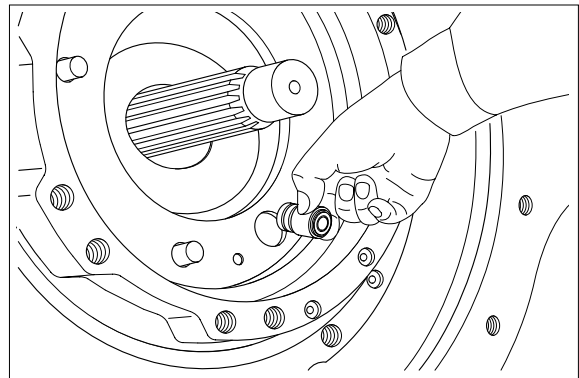

- ⑩ Remove swash plate(201).

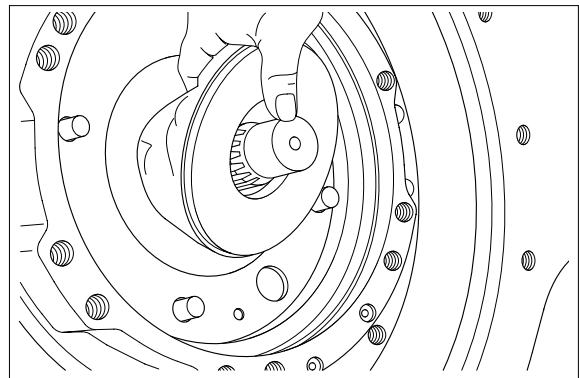

- ⑪ Screw M12 bolt to swash plate supporter(202) and pull it out.

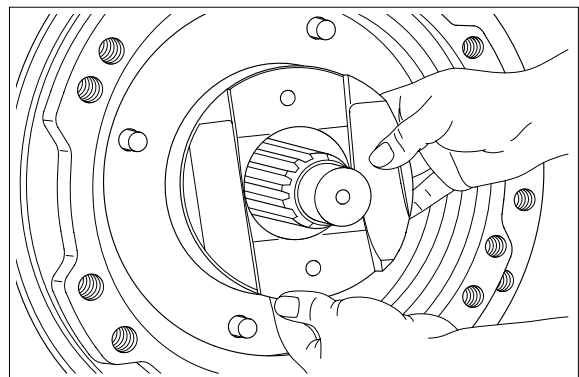

- ⑫ Pull out piston(501) and stopper S (504).

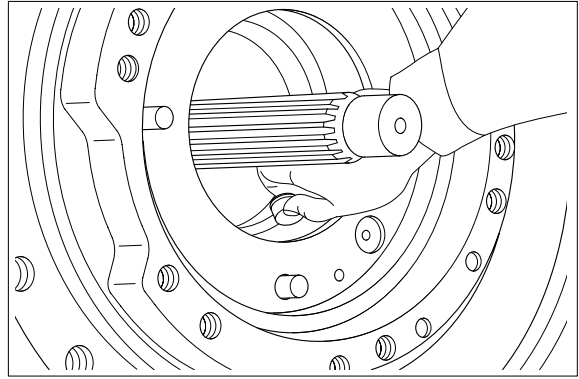

- ⑬ Hit front side end face of shaft(101) lightly with plastic hammer or so to remove casing(272).

- ※ Don't remove cylindrical roller bearing (102) as far as it remains normal.

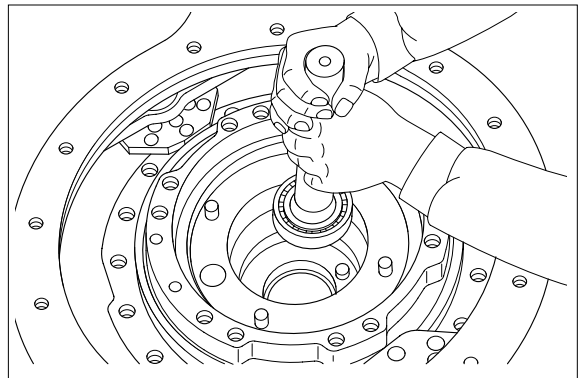

(2) Disassembling of valve casing sub-assembly

- ① Remove rod(505), spring(533), and spool(531).

- ※ Don't touch hexagon nut(507) and hexagon socket headless set screw(506) with hand, since this may change adjusted flow valve.

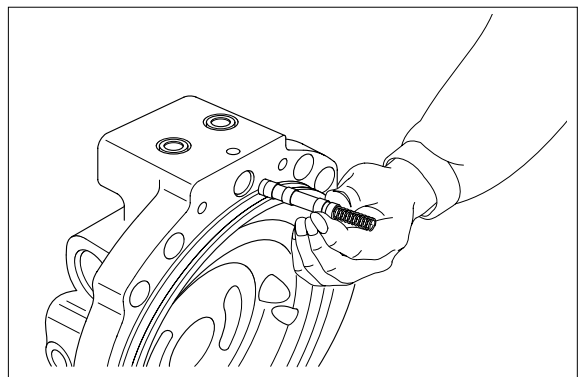
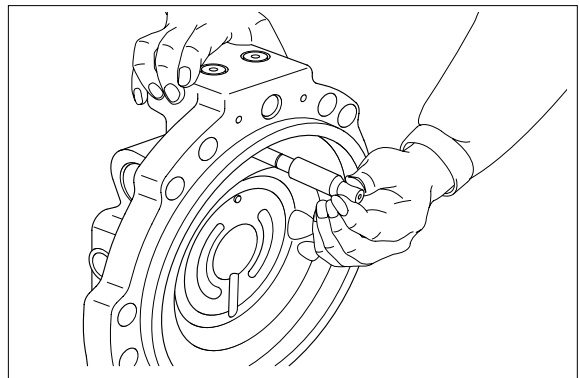

(3) Disassembling of motor main body

① Remove hexagon socket head cap screw(366) and cover(364), and then remove counterbalance spool(360) sub-assembly.

※ When any abnormality is found in counterbalance spool, counterbalance spring, etc. replace counterbalance spool sub-assembly as a set.

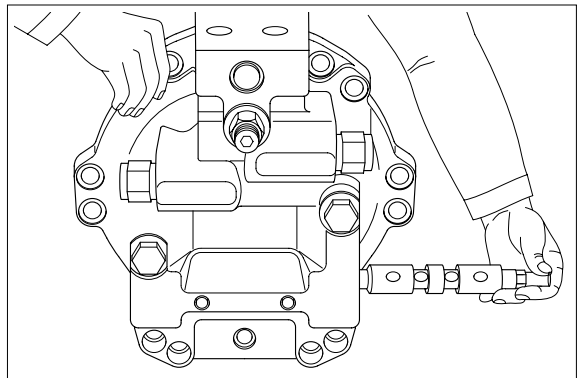
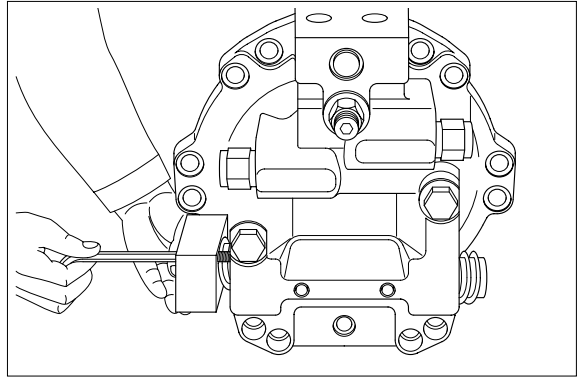

② Remove relief valve sub-assembly(350).

※ Don't remove needle bearing(103) as for as it remains normal.

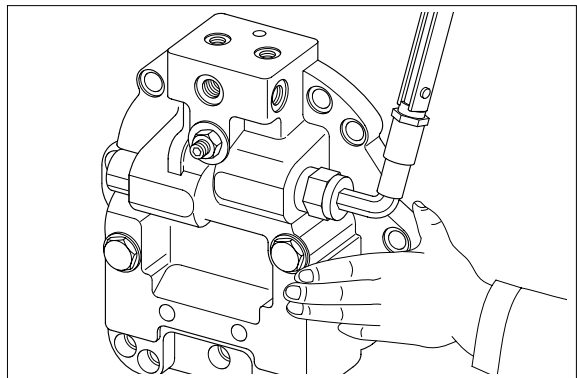

③ Remove ROplug(567) and remove check valve sub-assembly.

※ When no abnormality is found in displacement changeover, it is not necessary to overhaul it specifically.

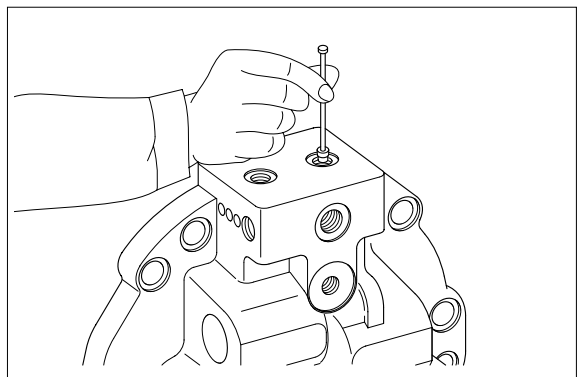

(4) Disassembling of cylinder sub-assembly

- ① Pull out set plate(123), piston(121), and shoe(122) sub-assembly.

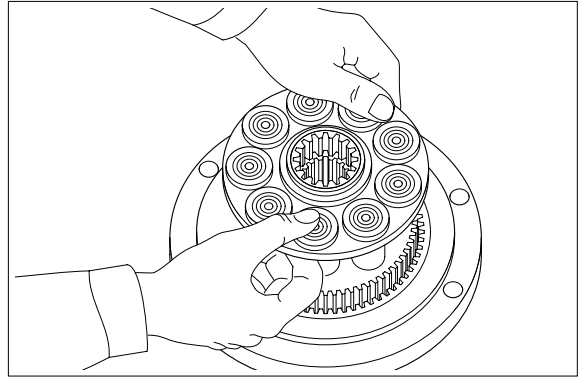

- ② Remove friction plate(742) and separator plate(741) from cylinder block(111).
Remove spherical bush(113), spacer(116) and cylinder spring(114).

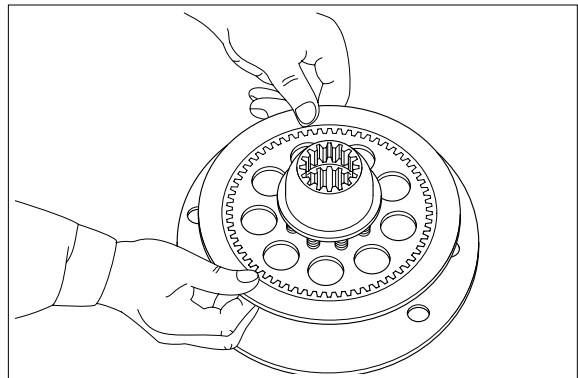

That is all of the disassembling work.

The pins(451, 452, 709) force-fitted to the valve casing and casing cannot be removed.

5. ASSEMBLING

1) GENERAL CAUTIONS

- (1) Clean each part fully with washing oil and dry it by blasting compressed air. It is better not to use waste cloths as much as possible.
However, if they are to be used, use clean ones, and pay attention to not leaving lint and so on.
Don't clean the friction plate with washing oil without fail.
- (2) Use the torque wrench in tightening fitting screws and plugs to their respective torque shown in Table 6.
- (3) When hammering is required, use the plastic hammer and try to hit parts lightly.
- (4) Similarly to the disassembling procedures, the numeral in parentheses following each part name indicates its part number shown in the attached **assembly drawings**.

2) ASSEMBLY OF MOTOR

(1) Assembling driving shaft sub-assembly

- ① Put bearing spacer(106) on shaft(101), and assemble cylindrical roller bearing(102).
- ※ Interference-fit cylindrical roller bearing.
 - ※ Pay attention to not damaging oil seal sliding area of driving shaft.

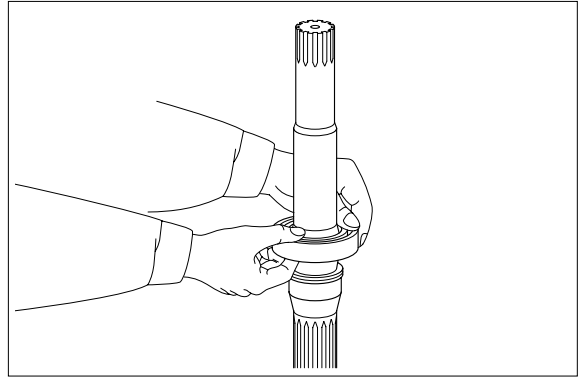

- ② Fit retaining ring(107) with pliers.
- ※ Pay attention to not fitting retaining ring the other way around.

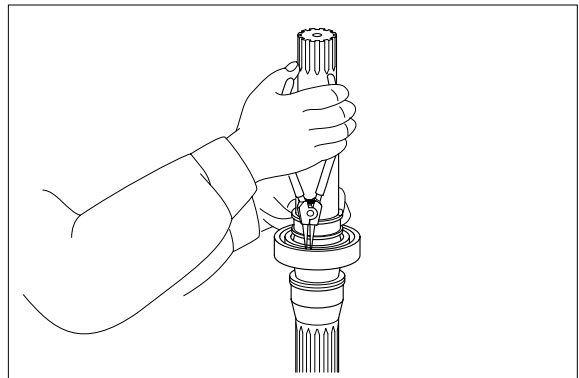

(2) Assembling of valve casing sub-assembly

- ① Tighten plugs(461) into valve casing(303) with specified torque.
- ※ Tighten them in five positions.
- ② Interference-fit pin(451).
 - ③ Interference-fit needle bearing(103).

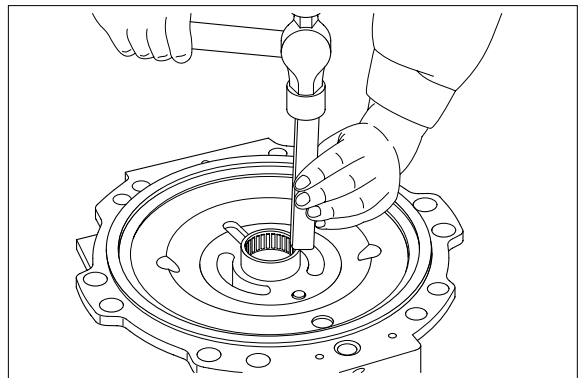

- ④ Assemble seat(541), steel ball(543), stopper(542) and ROplug(567) in the order named.
- ※ Pay attention to not assembling seat and stopper the other way around.

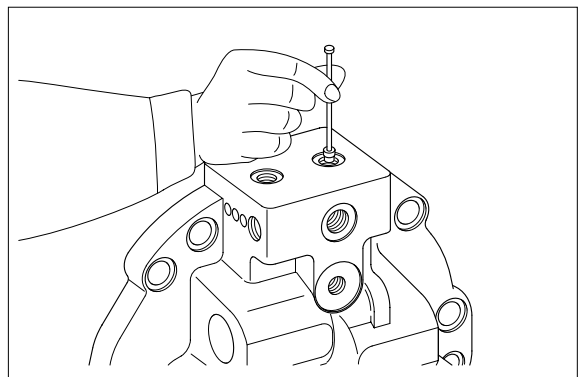

⑤ Mount relief valve sub-assembly(350).

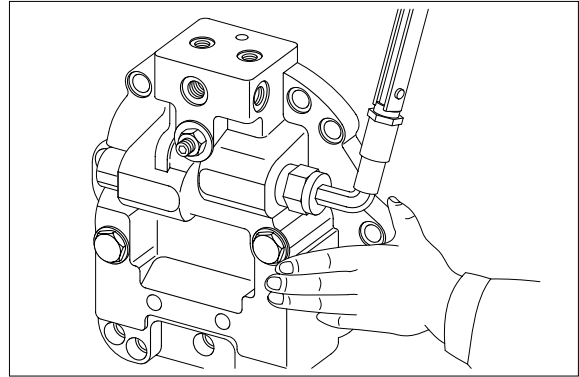

⑥ Assemble counterbalance spool(360), washer(361), spring(362) and bush(363) in the order named.

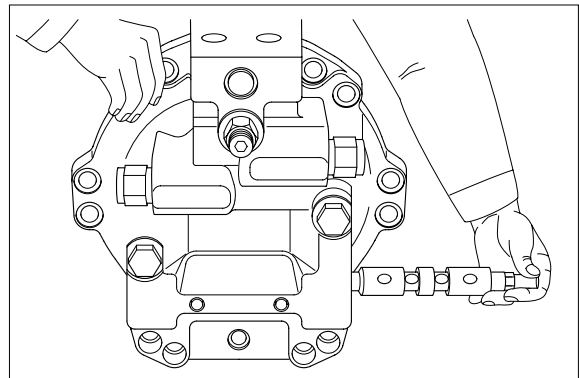

⑦ Fit cover(364) by tightening hexagon socket head cap screws(366).

※ Confirm that O-ring(365) has been inserted in cover.

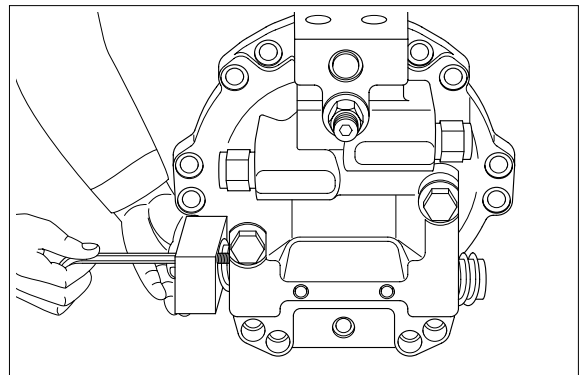

⑧ Fit hexagon socket headless set screw(506) and hexagon nut(507).

※ When newly assembled, flow should be adjusted.

- ⑨ Assemble spool(531), spring(533) and plug(571).

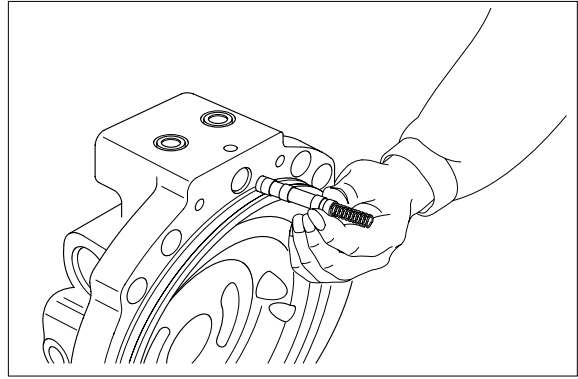

- ⑩ Assemble rod(505).
※ Confirm that O – ring(511) has been fitted.

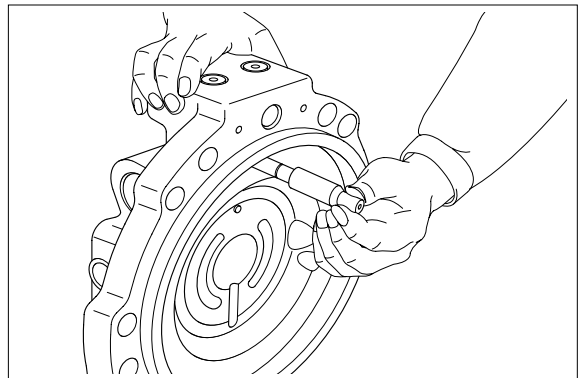

(3)

- ① **Assembling of cylinder sub-assembly**
Fit cylinder spring(114), spacer(116), and
※ spherical bush(113) to cylinder(111).
Match spline phase of cylinder to that of
spherical bush.

- ②
Fit friction plate(742) and separator
plate(741) into cylinder.

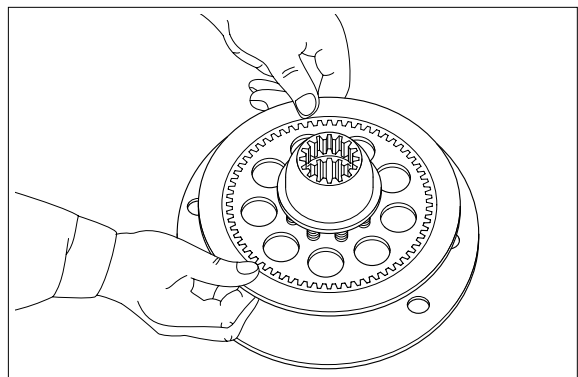

- ③ Put piston(121) / shoe(122) sub-assembly in seal plate(123) and then assemble them to cylinder.

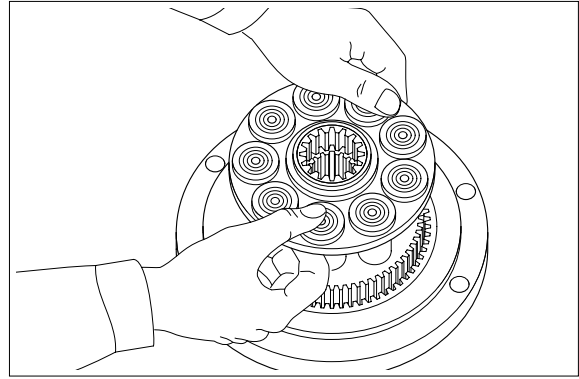

(4) Assembling of seal cover sub-assembly

- ① Interference-fit oil seal(491).
※ Pay attention to not damaging lip of oil seal.
② Assemble O – ring(471).

(5) Assembling of motor main body

- ① Tighten plugs(461) into casing(272) to specified torque.
※ Tighten them in five positions.
② Interference-fit pins(452, 709).

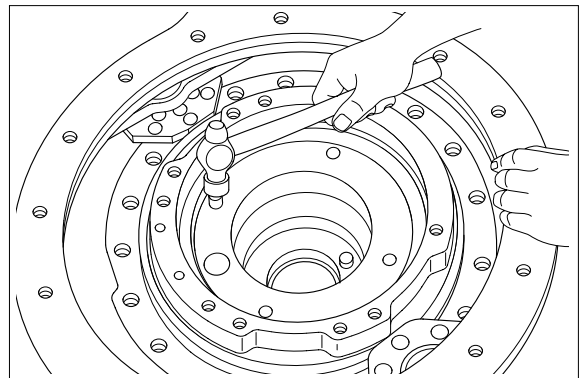

- ③ Interference-fit the shaft sub-assembly.
※ Interference-fit outer race of cylindrical roller bearing(102) by hitting lightly with hammer, utilizing key.

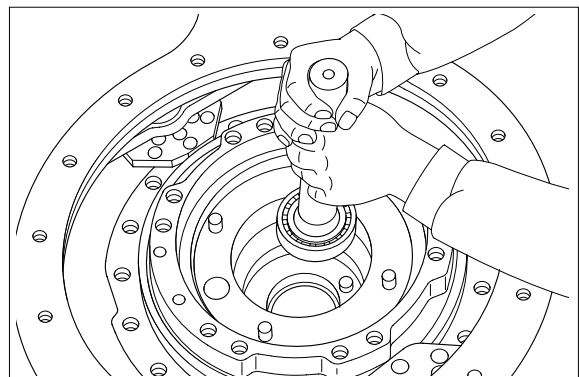

- ④ Assemble swash plate supporter (202), utilizing M12 screws.
- ※ Pay attention to not fitting swash plate supporter the other way around.

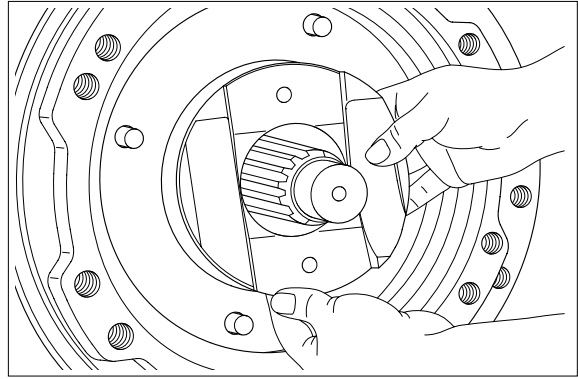

- ⑤ Assembling stopper S(504) and piston (501).
- ※ Fit O – ring(509) and back-up ring(510) to stopper.
 - ※ Pay attention to not fitting stopper the other way around.

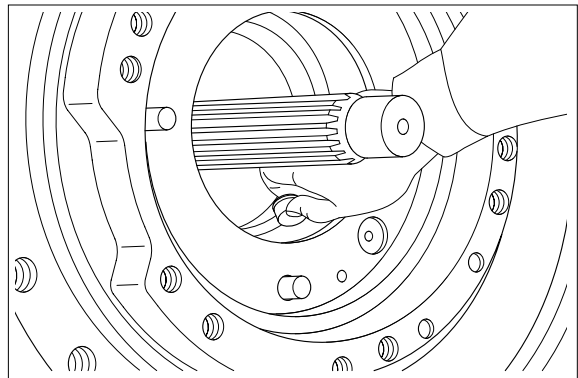

- ⑥ Assemble swash plate(201) onto swash plate supporter.
- ※ Apply grease on sliding area of swash plate rear surface.
 - ※ Confirm with finger tips of both hands if swash plate moves smoothly.

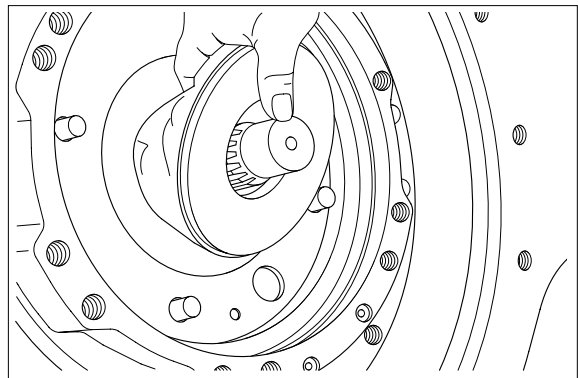

- ⑦ Assemble piston(501) and stopper L (503).

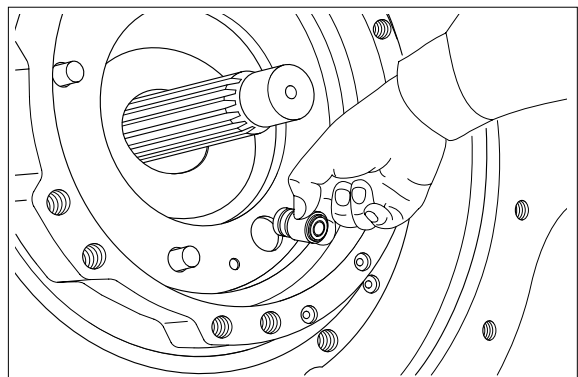

- ⑧ Change position of casing(272) from vertical one to horizontal one.
※ Pay attention to not dropping swash plate.

- ⑨ Mount cylinder sub-assembly.
※ Mate hole of separator plate to pin.

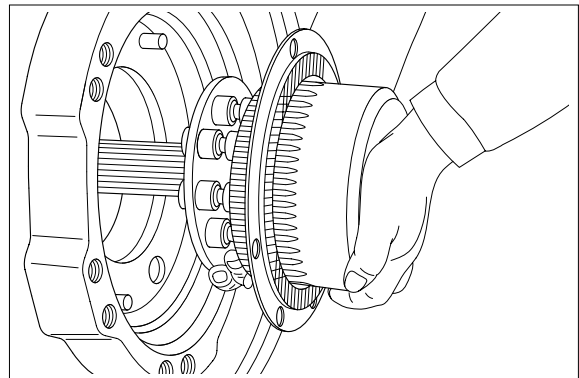

- ⑩ Change position of casing(272) from horizontal one to vertical one.
⑪ Fit piston ring 252(707) and piston ring 278(708) to brake piston(702).

- ⑫ Assemble break piston into casing.
※ Pay attention to not fitting brake piston the other way around.

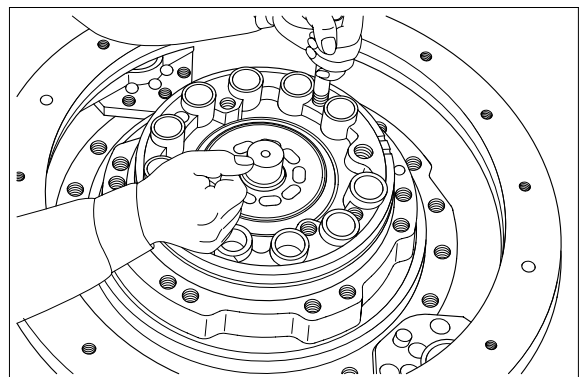

- ⑬ Assemble break spring(705).

- ⑭ Assemble orifices(545, 546) and tighten them to specified torque.
※ They are provided in three positions.
Fit O-rings(547) without fail.

- ⑮ Fit piston ring 252(707) and piston ring 278(708) to brake piston(702).

- ⑯ Fit valve plate(131) to valve casing(303), assemble them to casing, and then tighten them with hexagon socket head cap screws(401, 402).
※ Apply grease on valve plate rear surface and pay attention to not dropping valve plate.

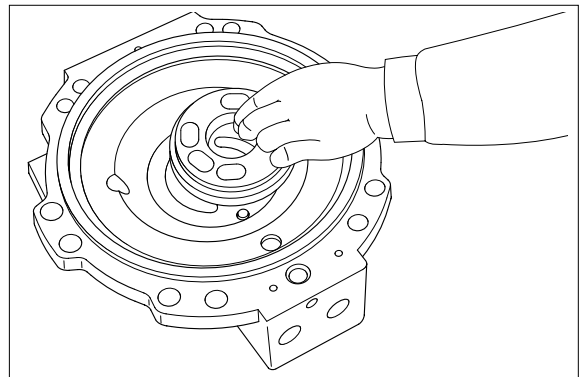

- ※ Use crane in assembling valve casing to casing.

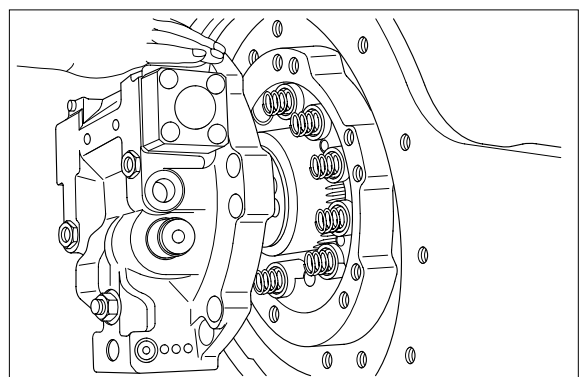

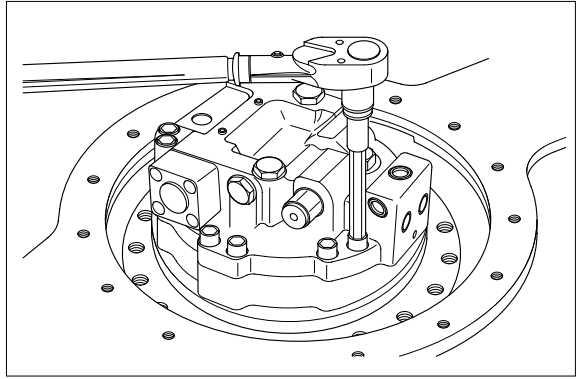

- ⑰ Tighten to specified torque plugs, relief valve, etc. fitted to valve casing sub-assembly.

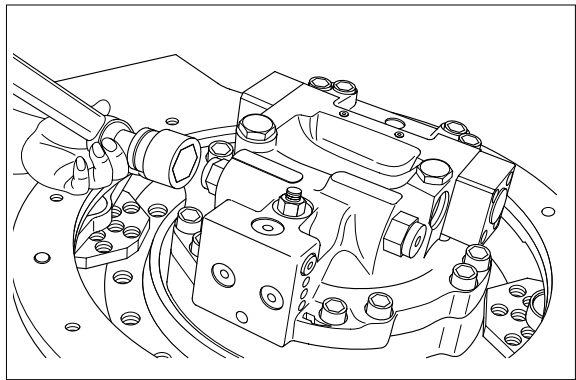

- ⑱ Mount seal cover sub-assembly.

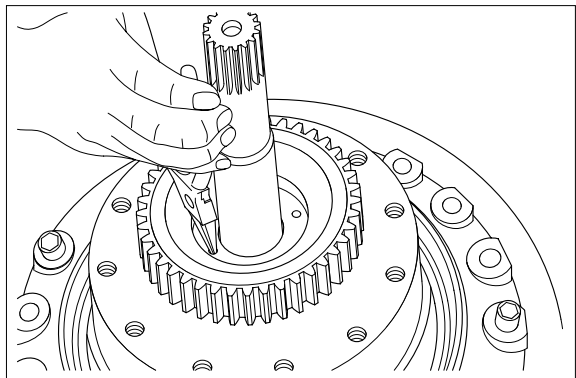

3) ASSEMBLY OF REDUCTION GEAR

(1) Place housing(2) with its front side up, and fit angular bearings(33) with their back faces mated.

- ※ Fit angular bearings one by one with press or key hammer.
- ※ Push outer race side only without fail.

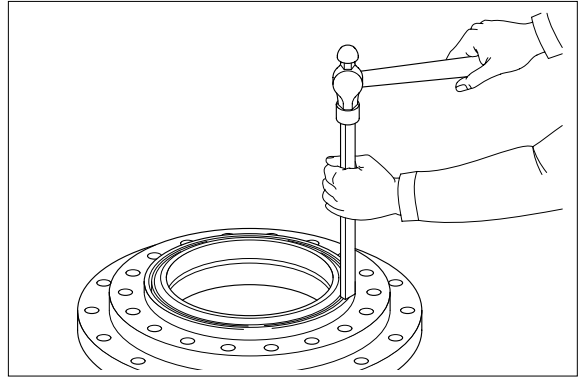

(2) Place ring gear(1) with its rear side up, degrease and dry mating faces, and then apply liquid packing to them uniformly.

- ※ When ring gear is to be reused, remove screw lock of its tapped holes with M20 tap.

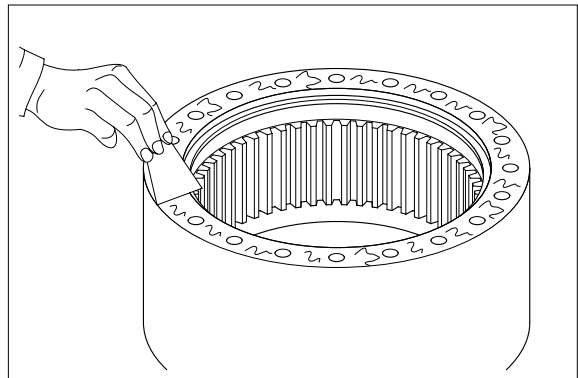

(3) Screw M20 eyebolt to housing, lift it up with crane, and place it on ring gear, mating their respective thread holes.

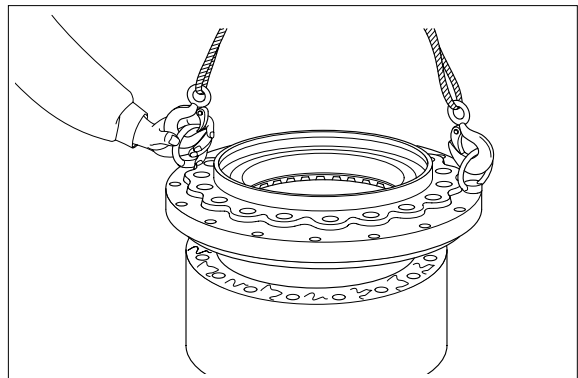

(4) Apply screw lock to hexagon socket head cap screws(29) and tighten them to specified torque with torque wrench.

- ※ Degrease and dry tapped hole of ring gear and screw in advance.
- Before tightening screws, lock ring gear.

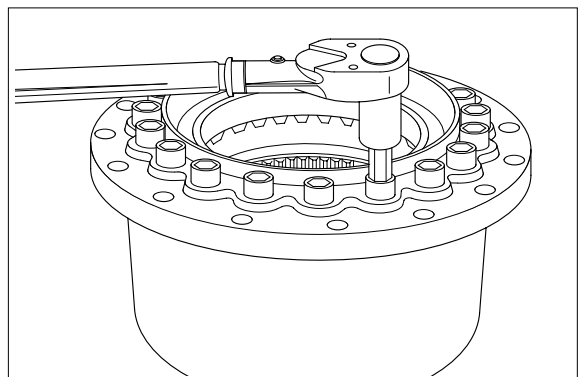

- (5) Fit O-ring to floating seal(34) with out twisting it, and then to housing(2).
※ Apply grease to O-ring thinly.

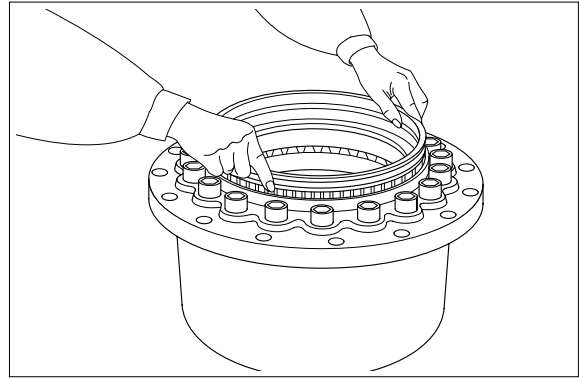

- (6) Similarly, fit floating seal to casing(272) of hydraulic motor.

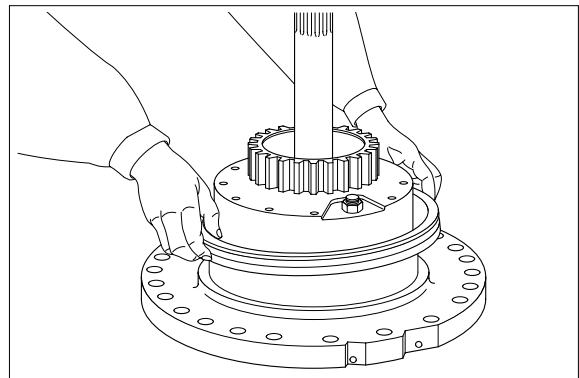

- (7) Lift up drum sub-assembly assembled in Items 1 through 5 with its floating seal side down, and put inner diameter of angular bearing on outer diameter of casing.
※ Pay attention to not damaging sliding faces of floating seal.

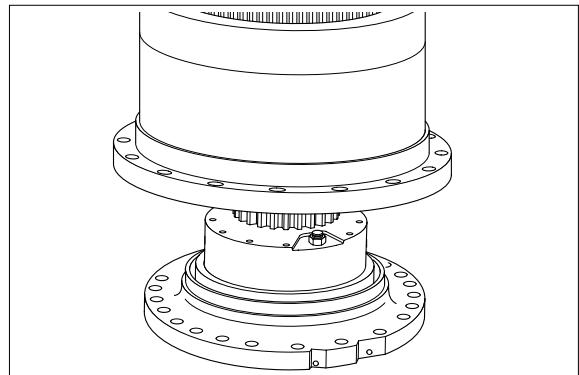

- (8) Place jig on inner race of angular bearing and push it down with press until end face of inner race touches shoulder of casing firmly.
※ When press is not available, place drum assembly jig on inner race and tighten long M12 screws to push down bearing until it touches shoulder.

- (9) With bearing pushed down, measure level difference between bearing end face of front side and casing mating face with depth gage.

This dimension is referred to as **a**

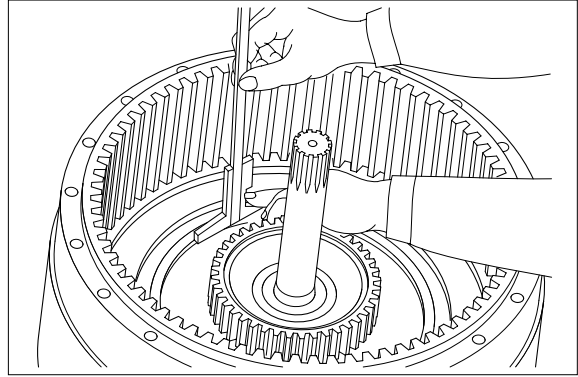

- (10) Measure level difference of bearing retainer(008).

This dimension is referred to as **b**

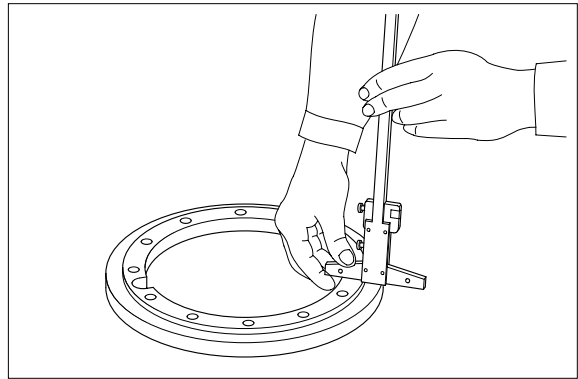

- (11) Calculate thickness of shim δ with the following formula and select shim of this thickness.

$$\delta = b - a - (-0.05 \text{ to } 0.1)$$

- ※ Bearing is to have from pre-compression of 0.05mm to clearance of 0.1mm axially.

- (12) Remove jig and place above-selected shim(035) on inner race of angular bearing(033).

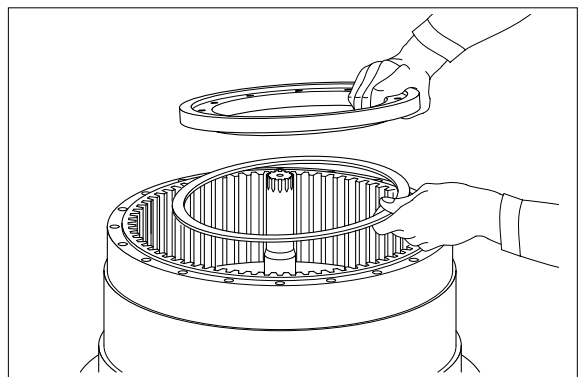

- (13) Place bearing retainer(008) on the above, apply screw lock on hexagon head bolt(031), and tighten it to specified torque.
 ※ Degrease and dry tapped hole of casing and screw in advance.

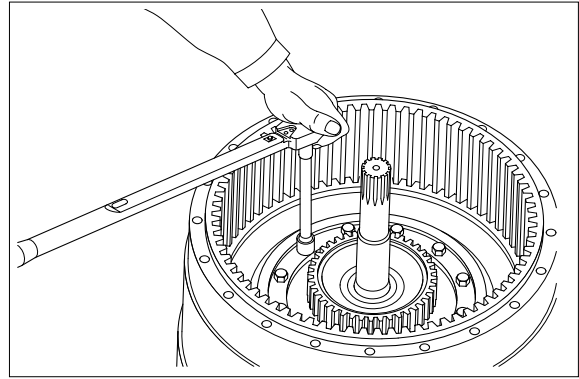

(14) Assembling of carrier 3 sub-assembly

- ① Place carrier 3 with its spline side down.
 - ② Put needle bearings(23) into inside of carrier 3, holding them between side plates(20).
 - ③ Insert No.3 pin(17) into carrier 3.
 - ④ Drive spring pins(37) into pin holes of carrier 3 and pins 3, and punch at two points as shown in right figure to lock it.
- ※ Mate pin hole of carrier with center of planetary gear.
 Mate spring pin holes of them with each other.

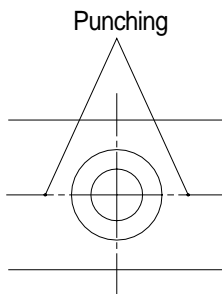

- (15) Screw two M10 eyebolts into carrier 3 sub-assembly and assemble it with crane, paying attention to its meshing with planetary gear 3 and ring gear.
 ※ Spline-couple carrier 3 and casing(272) so that their relative position will be as shown in the following figure.

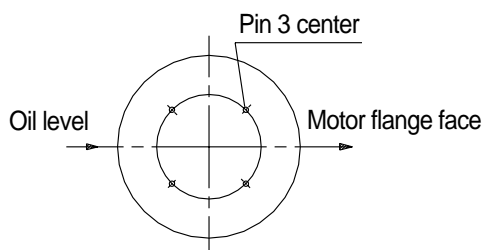
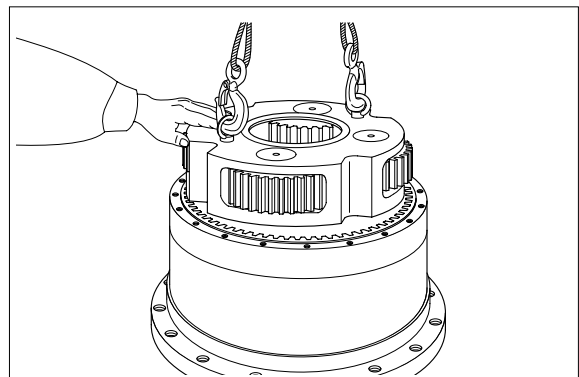

(16) Assembling carrier 2 sub-assembly

- ① Assemble thrust ring(25) to sun gear 3(11).
- ② Assembling carrier 2(6) to sun gear 3(11), and fit retaining ring.
- ③ Place carrier 2 with sun gear 3 up.

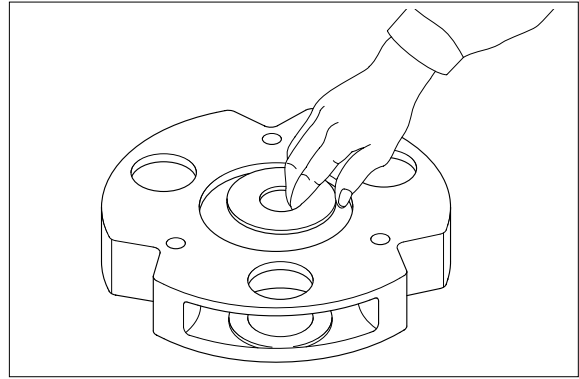

- ④ Put needle bearings(22) into inside of planetary gear 2(13), and insert them into carrier 2, holding them between side plates(20).

Mate pin hole of carrier with center of planetary gear.

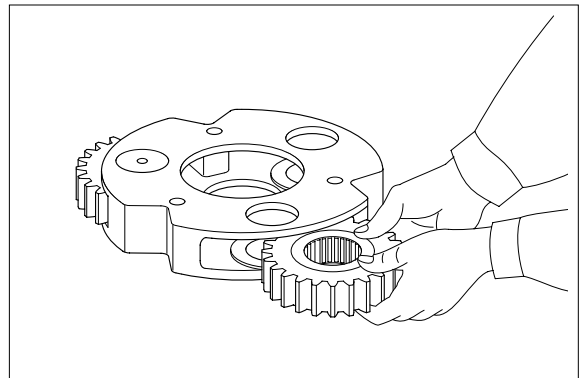

- ⑤ Insert pins 2(16) into carrier 2.
 - ⑥ Drive spring pins(37) into pin holes of carrier 2 and pin 2, and punch at two points as shown in right figure to lock it.
 - ⑦ Assemble thrust ring(26) to carrier 2(6).
 - ⑧ Turn over carrier 2 and place it with sun gear 3 down.
- ※ Mate spring pin holes of them with each other.

- (17) Screw two M10 eyebolts into carrier 2 sub-assembly, and assemble it with crane, paying attention to its meshing with planetary gear 2 and ring gear.

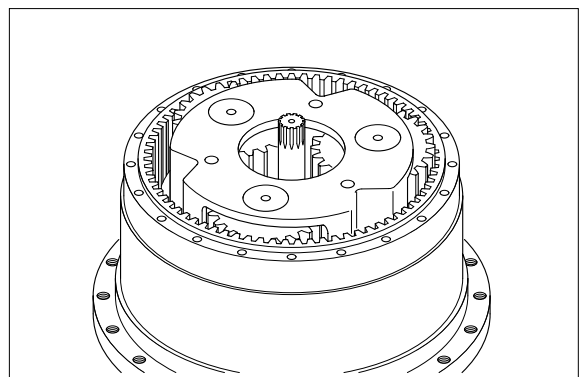

(18) Assembling of carrier 1 sub-assembly

- ① Interference-fit pins 1(15) to carrier 1(5).
 - ② Drive spring pins(37) into pin holes of carrier 1 and pin 1, and punch at two points similarly to items (14), ④ and (16), ④ to lock it.
- ※ Mate spring pin holes of them with each other.

- ③ Assemble carrier 1(5) to sun gear 2(10), and fit retaining ring(45).
- ④ Assemble thrust ring(24) to sun gear 2(10).

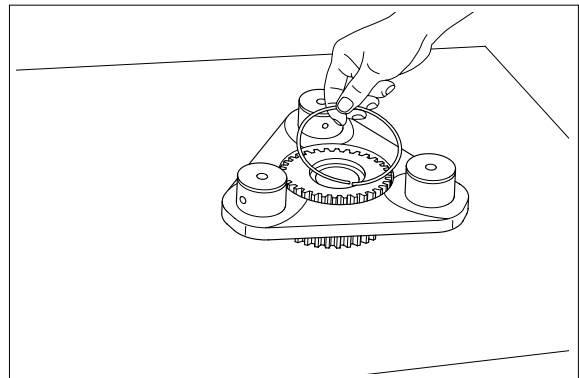

- ⑤ Put needle bearings(21) into inside of planetary gear 1(12), and assemble them, holding them between side plate 50A(18) at rear side and side plate 50B(19) at front side. Then fit retaining ring(44) on them.

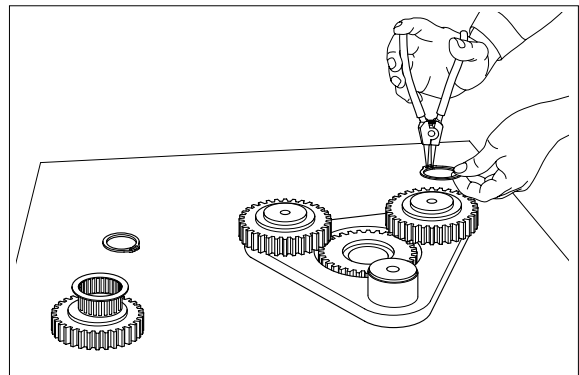

(19) Assemble carrier 1

Sub-assembly, paying attention to its meshing with planetary gear 2 and sun gear 2.

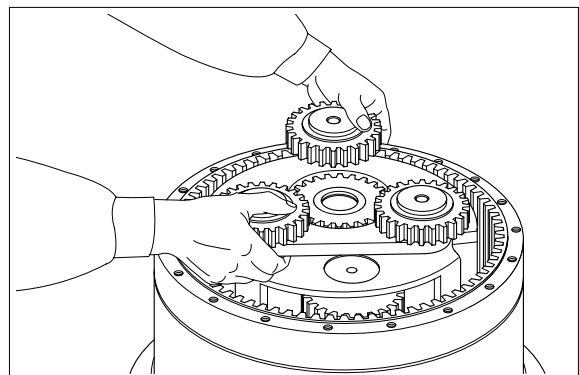

- (20) Assemble sun gear 1(9), paying attention to its meshing with motor shaft spline planetary gear 1.

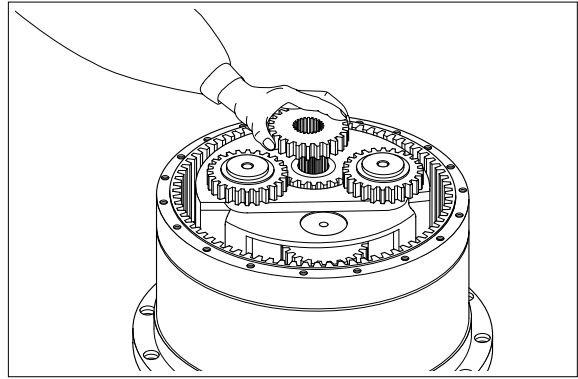

- (21) Measure height **H** from side cover(004) mating face to ring gear(001) mating face with straight edge and depth gage.

- (22) Measure height **L** from side cover(004) mating face to center hold bottom with straight edge and depth gage.

- (23) Measure thrust ring(024) thickness **t** with vernier calipers, and obtain optimum shim thickness δ with the following formula.

$$\mathbf{H + t + \delta + (1.5 \text{ to } 2) = L}$$

- ※ Keep axial clearance between sun gear and thrust plate 1.5 to 2mm.

- (24) Place shim of above-selected thickness to center of side cover(004), and upon it force-drive thrust rings(024) with plastic hammer.

- (25) Degrease and dry mating faces of ring gear, and then apply liquid packing to them uniformly.

(26) Degrease and dry also mating faces of side cover. Then lift it up, utilizing M10 eyebolt, and place it on ring gear.

※ In this case, mesh side cover ring gear and planetary gear 1, and also mate their thread holes with each other.

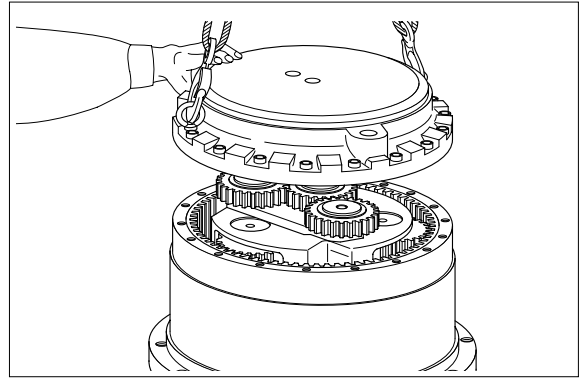

(27) Tighten hexagon socket head cap screws(30) to specified torque to fix side cover.

(28) Wind seal tape round plugs(32) and tighten them to side cover(4) to specified torque.

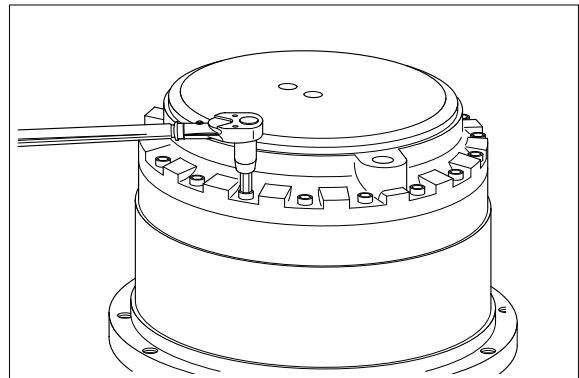

(29) Screw hexagon socket headless set screws(41) to tapped hole for pulling- out, until they touch hole bottom.

That is all of the assembling work. After fitting the motor this reduction gear, supply oil until overflows from the level gage.