

GROUP 5 SWING DEVICE

1. REMOVAL AND INSTALL OF MOTOR

1) REMOVAL

(1) Lower the work equipment to the ground and stop the engine.

(2) Loosen the breather slowly to release the pressure inside the hydraulic tank.

▲ Escaping fluid under pressure can penetrate the skin causing serious injury.

※ When pipes and hoses are disconnected, the oil inside the piping will flow out, so catch it in oil pan.

(3) Disconnect pipe assy(2, 3)

(4) Disconnect pilot line hoses(4, 5, 6, 7, 8)

(5) Sling the swing motor assembly(1) and remove the swing motor mounting bolts(9)

· Motor device weight : 319kg(703lb)

· Tightening torque : 58.4kgf · m
(422.4lbf · ft)

(6) Remove the swing motor assembly.

※ When removing the swing motor assembly, check that all the piping have been disconnected.

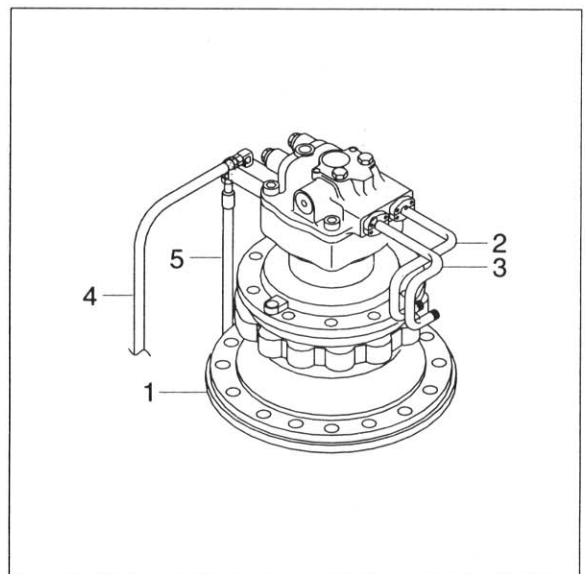

2) INSTALL

(1) Carry out installation in the reverse order to removal

(2) Bleed the air from the swing motor.

① Remove the air vent plug.

② Pour in hydraulic oil until it over flows from the port.

③ Tighten plug lightly.

④ Start the engine, run at low idling, and check oil come out from plug.

⑤ Tighten plug fully.

(3) Confirmed the hydraulic oil level and check the hydraulic oil leak or not.

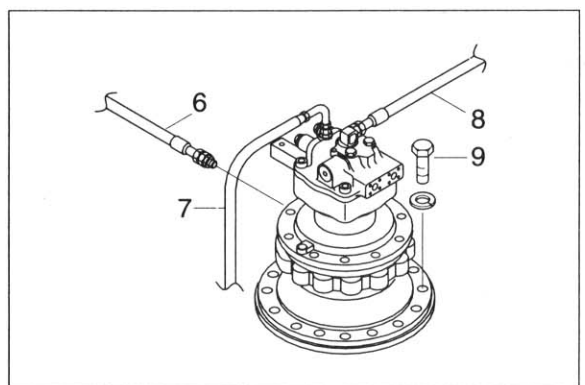

2. SWING MOTOR

1) STRUCTURE

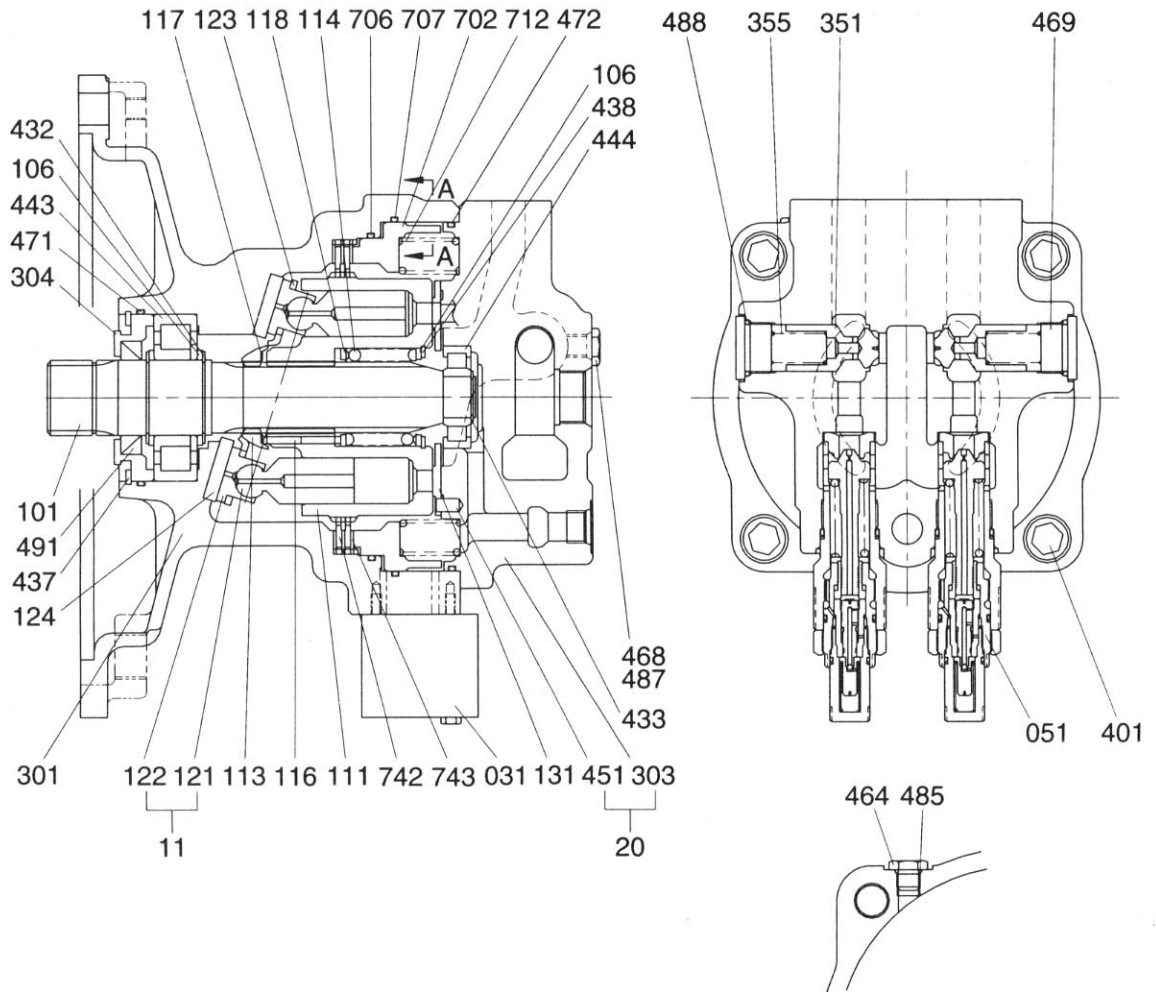

SECTION A-A

11	Piston sub	301	Casing(A)	469	RO plug
20	Valve casing sub(H1)	303	Valve casing(H1)	471	O-ring
101	Drive shaft	304	Front cover	472	O-ring
106	Spacer	351	Plunger(H)	485	O-ring
111	Cylinder	355	Spring(H)	487	O-ring
113	Retainer	401	Hex socket bolt	488	O-ring
114	Cylinder spring	432	Snap ring	491	Oil seal
116	Push rod	433	Snap ring	702	Brake piston
117	Spacer(F)	437	Locking ring	706	O-ring
118	Spacer(R)	438	Locking ring	707	O-ring
121	Piston	443	Roller bearing	712	Brake spring
122	Shoe	444	Roller bearing	742	Friction plate
123	Plate set	451	Pin	743	Separator plate
124	Shoe plate	464	VP plug	051	Relief valve
131	Valve plate	468	Plug	031	Time delay valve

2) DISASSEMBLY

- (1) Lift the motor out. Clean the motor in kerosene and dry with compressed air.
※ To avoid dust inside the motor, mask all the ports of the motor with tapes.

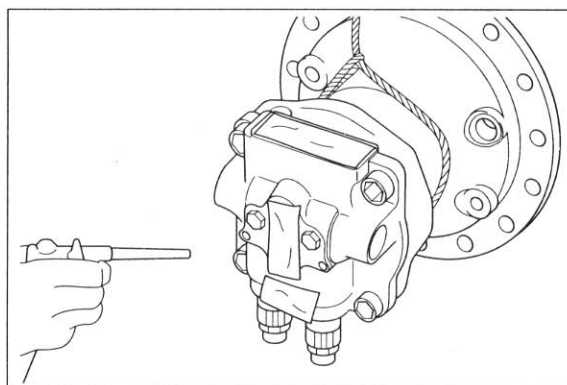

- (2) Loosen the drain plug to discharge oil in the casing(301)

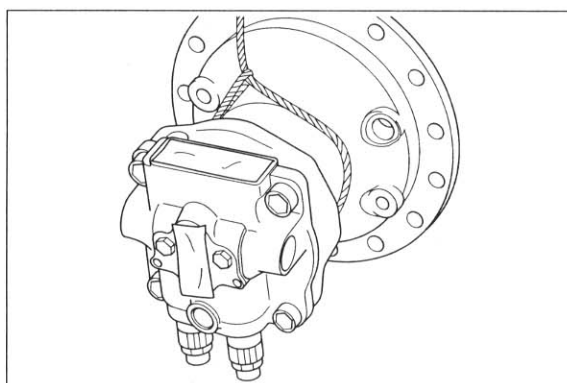

- (3) Fix the output shaft(101) on the workbench with the end of output shaft down. Put matching marks on casing(301) and valve casing(303) for easy reassembly.

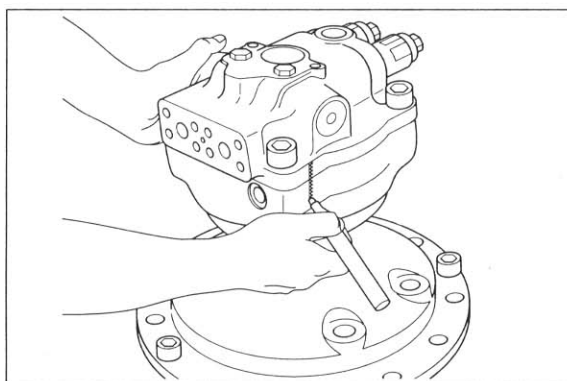

- (4) Remove the valve(031)

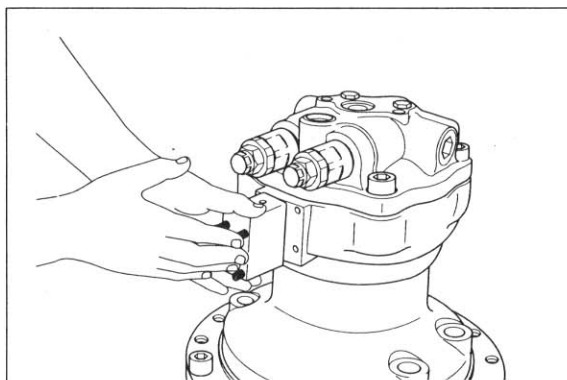

- (5) Remove the relief valve(051) from valve casing(303).

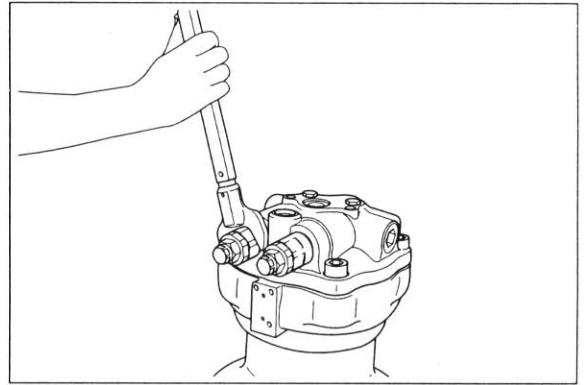

- (6) Remove RO plug(469) from valve casing(303) and spring(355), plunger(351).
Be careful not to damage the plunger seat assembly.

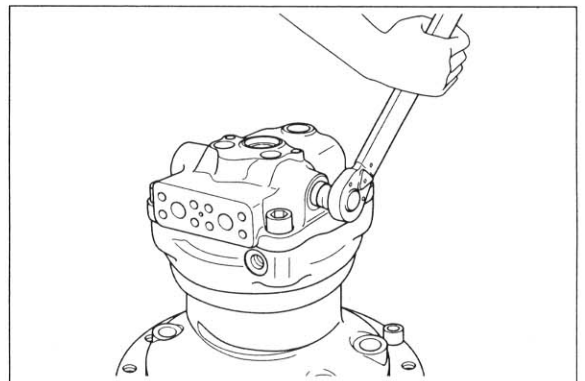

- (7) Remove valve casing(303) from casing(301). Then, remove the valve plate(131) from valve casing(303) with care.

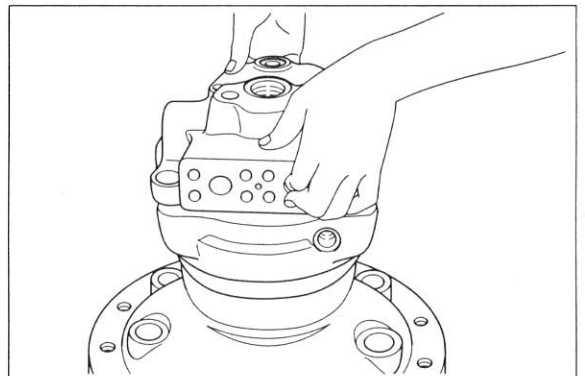

- (8) Remove the brake spring(712) from brake piston(702).

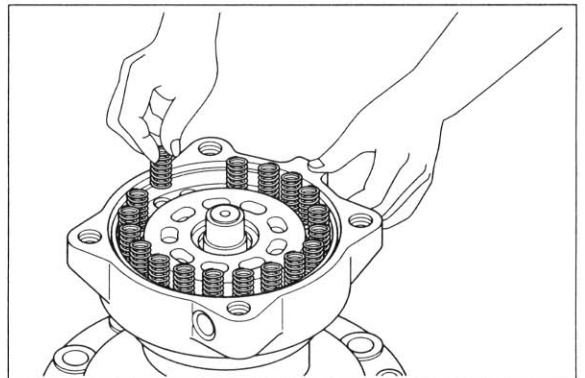

- (9) Remove brake piston(702) from casing(301).

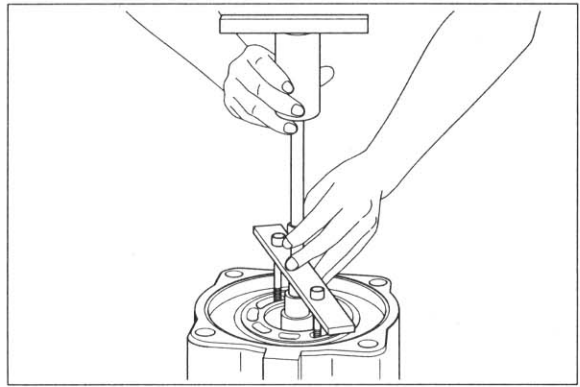

- (10) Remove the cylinder(111) from the output shaft (101) with the motor positioned horizontally. Remove piston(9121), pushing plate(123), spherical bush(113), spacer(117) and shoe plate(124).

※ If shoe plate would not be removed easily, try again after procedure(14).

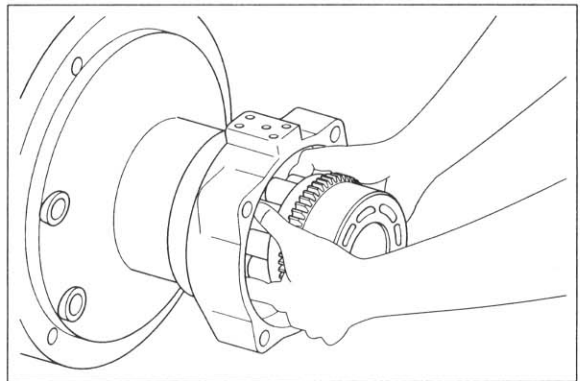

- (11) Remove friction plate(742) and separate plate(743) from casing(301).

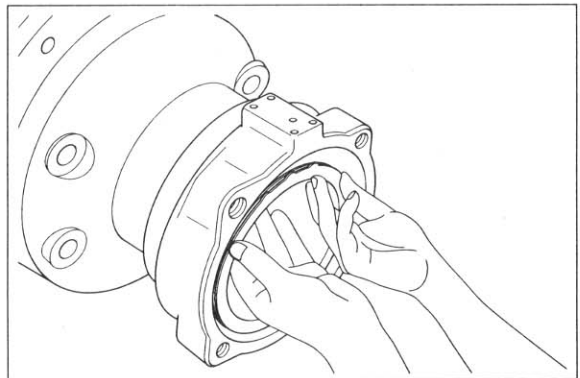

- (12) Remove locking ring(437) with plier and remove the front cover(304) from casing(301).

※ Front cover could be removed with sliding shaft if necessary.

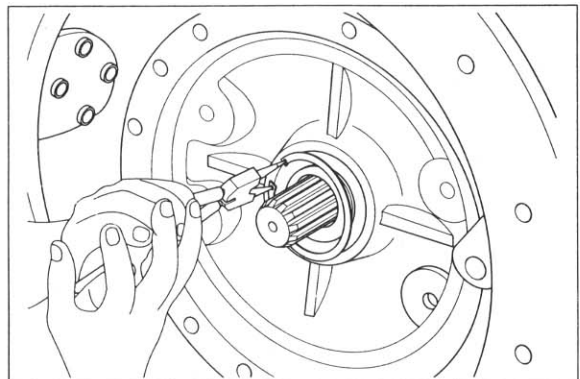

(13) Remove output shaft(101) from casing(301).

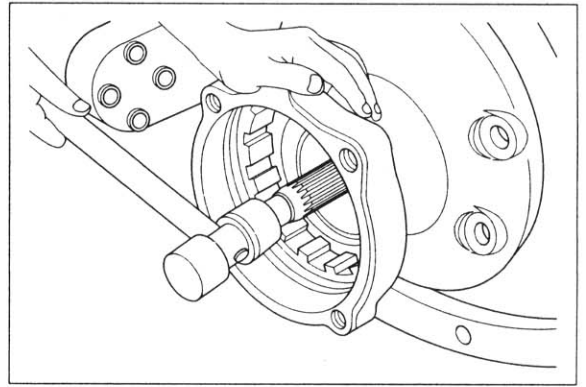

(14) Remove the shoe plate(124) from casing(301).

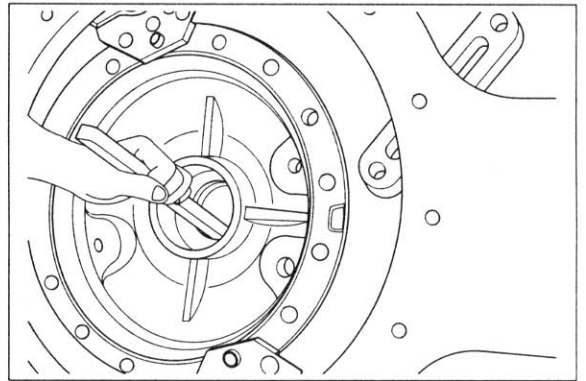

(15) Proceed with following job only when necessary.

- ① Remove the stop ring(432), spacer(106) from output shaft(101) and remove the cone of roller bearing(443) by press.

※ Do not reuse bearings.

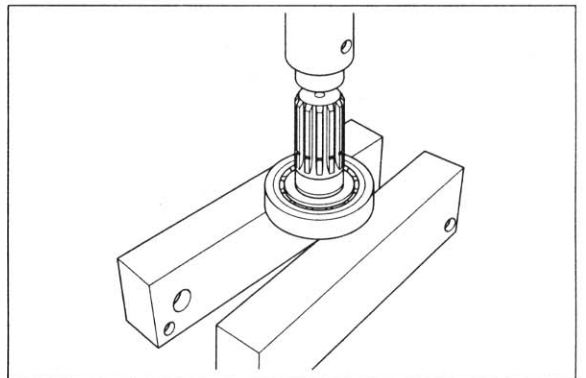
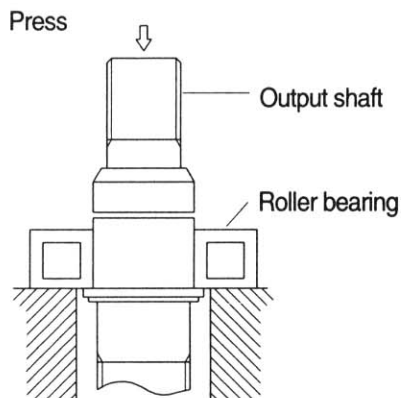

- ② Remove oil seal(491) from front cover(304).

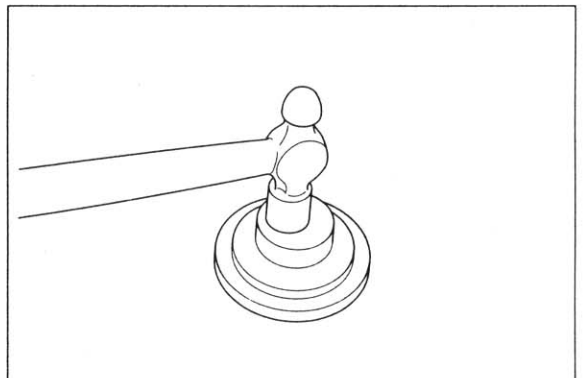

- ③ Remove the roller bearing(4440 from the valve casing(303) by using slide hammer bearing puller.

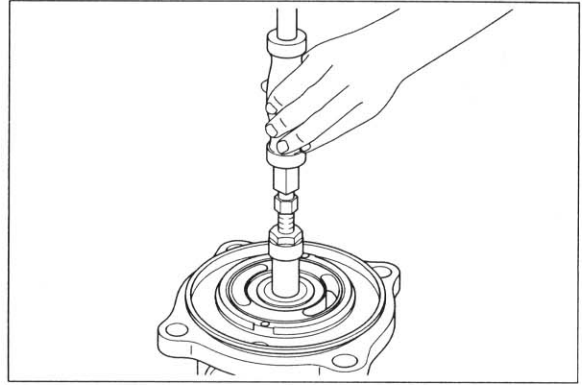

- ④ When disassembling the relief valve, release the plug(201) and remove the bush(343), spring(322), and spring seat(333) from the rod(3030 of the body(101). Remove the piston(302), rod(303), spring(321), spring seat(331) and plunger(301) with the body(101) downward.

※ Do not release the adjust bolt(471) and lock nut(472).

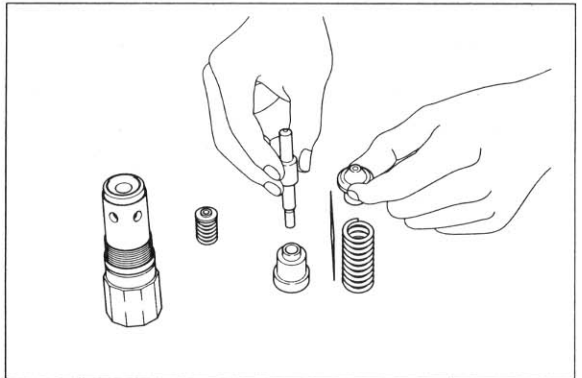
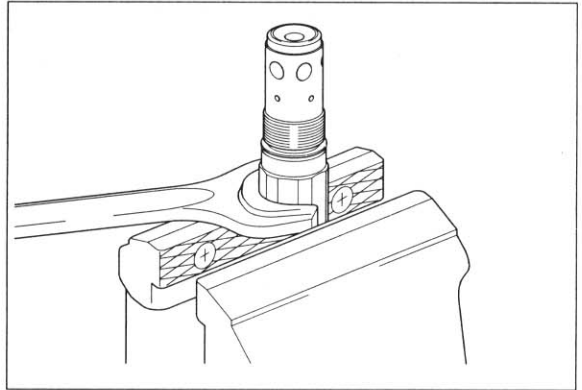

This completes disassembly.

3) ASSEMBLY

Do the reassembly in the reverse procedure of the disassembly.

- (1) Place the casing(301) on the workbench with the valve casing(303) downward.

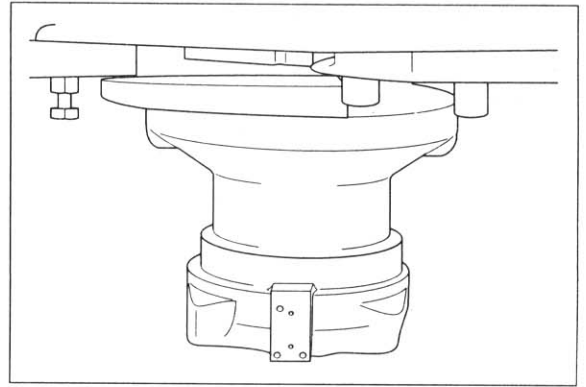

- (2) When reassembling the roller bearing, install the stop ring(432), and spacer(106) to the output shaft(101). Insert the collar and cone of the roller bearing(443). Install the spacer(106) and stop ring(432). Install stop ring(433) to the output shaft(101) by heating the cone of the roller bearing(444).

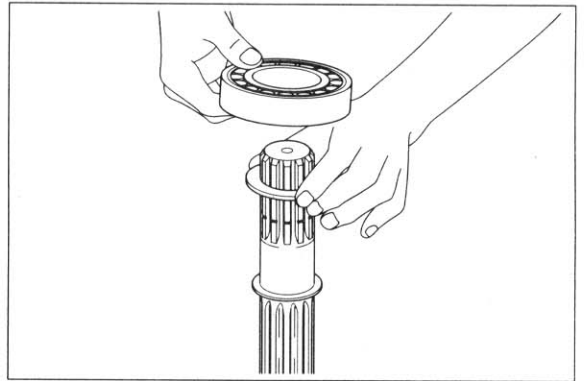

Out put

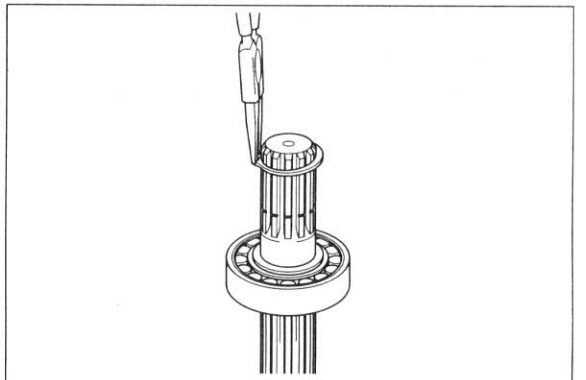
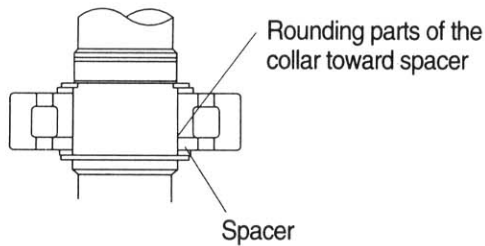

- (3) Insert the drive shaft(101) into the casing(301) with the end of output shaft upward and tap the outer race of roller bearing the hammer.

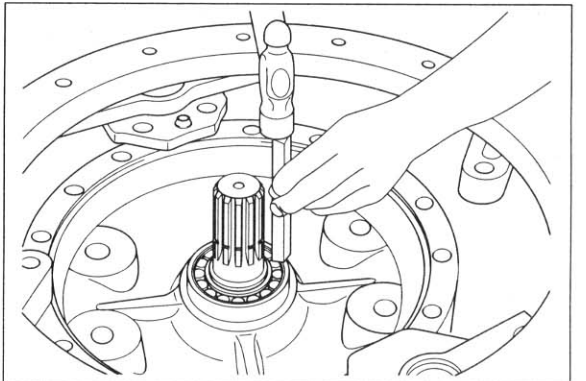

(4) Insert the output shaft(101) in the casing.

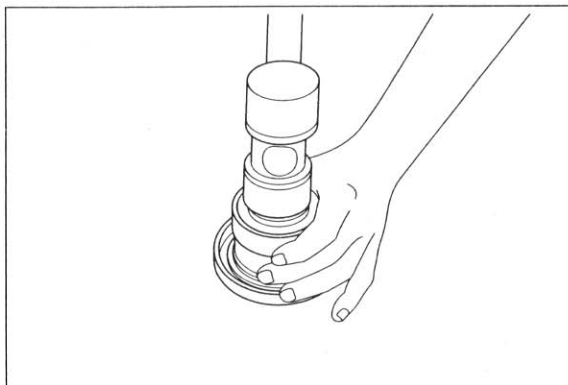

(5) Tack O-ring(471) to the casing(301).

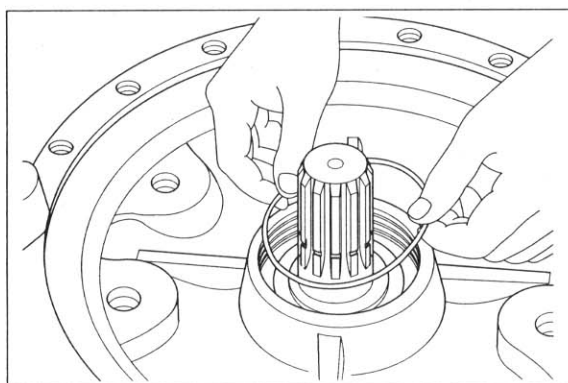

(6) Reassemble the front cover(304) to the casing(301).

※ Apply grease to the rib of oil seal to avoid damage to the rib.

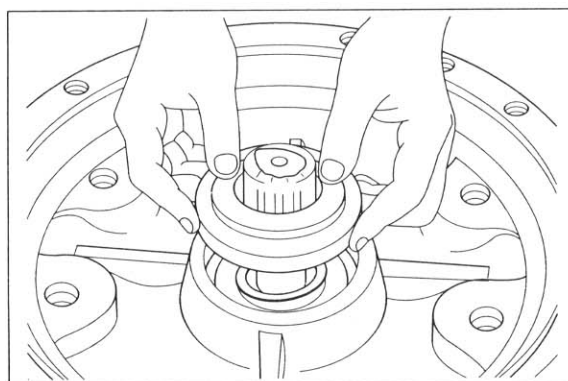

(7) Install the lock ring(437) to the casing(301).

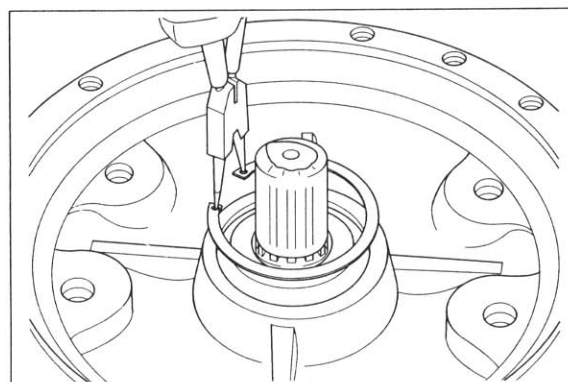

- (8) Insert the shoe plate(124) with the casing(301) position horizontally.

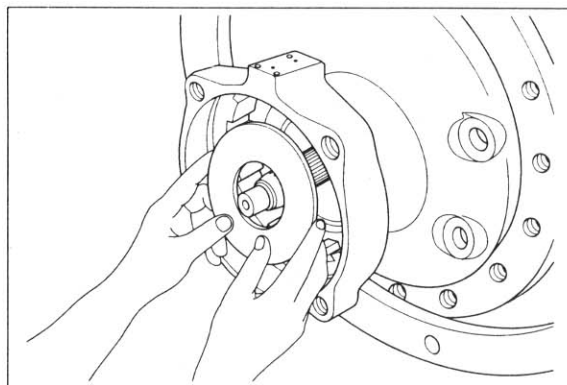

- (9) Insert the push rod(116) into the cylinder(111). Place the spherical bush(113) assembled with spacer F(117) onto the cylinder.

※ Insert two push rods in each hole.

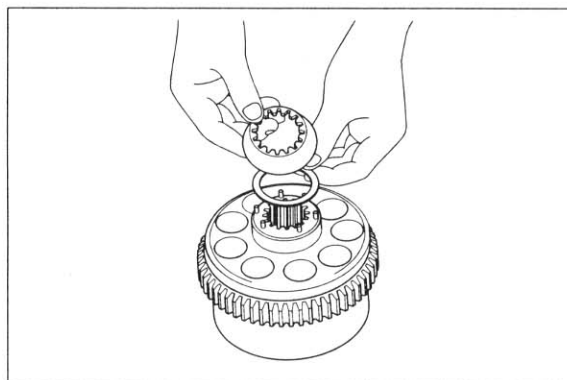

- (10) Install the piston sub-assembly(121, 122) to the push plate(123).

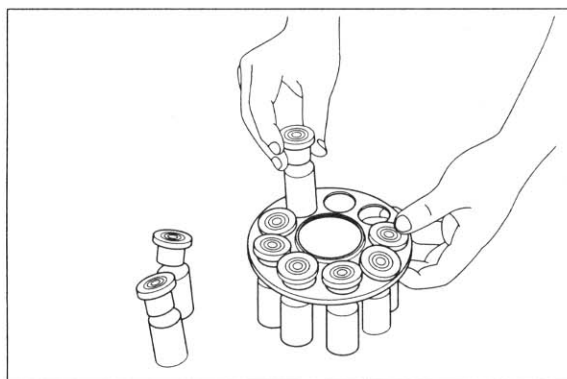

- (11) Reassemble the piston assembly(121, 122) to the cylinder(111).

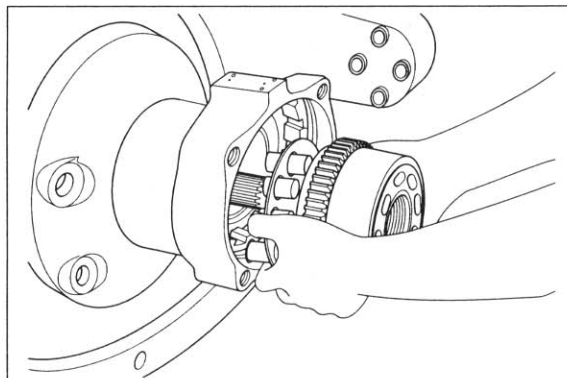

- (12) Place the casing(301) under the front cover(304) and reassemble 3 sheets of separate plate(743) and then 2 sheets of friction plate(742) to the casing(301).

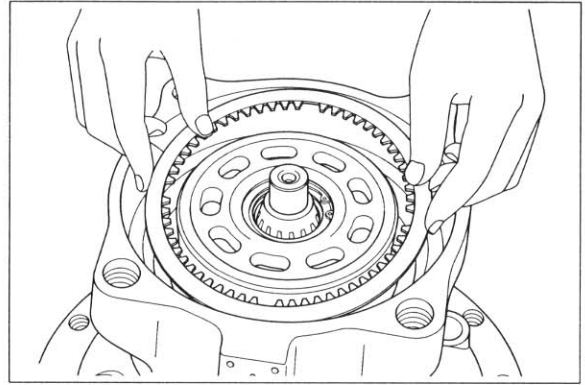

- (13) Insert O-ring(706, 707) in the casing (301).

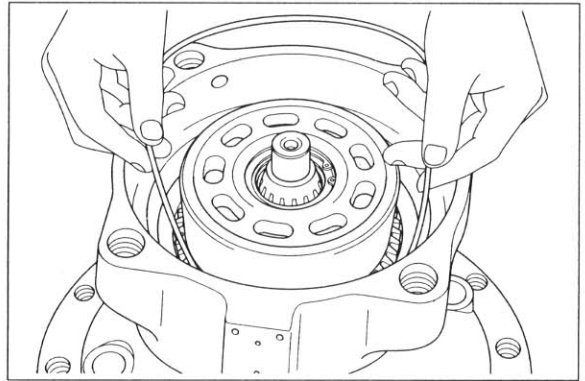

- (14) Reassemble brake piston(702) to the casing (301).

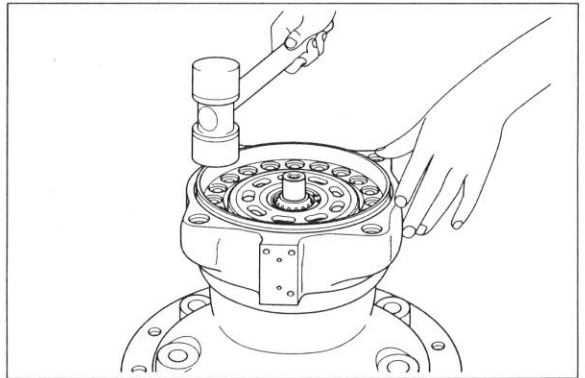

- (15) Reassemble brake spring(712) to the brake piston(702).

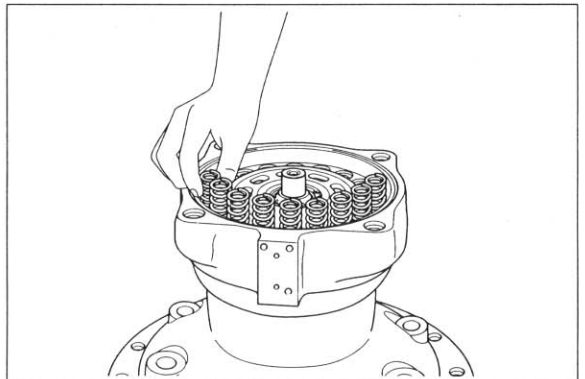

- (16) When the roller bearing(444) is removed.
Insert the roller bearing(444) into valve casing(303) with hammering.

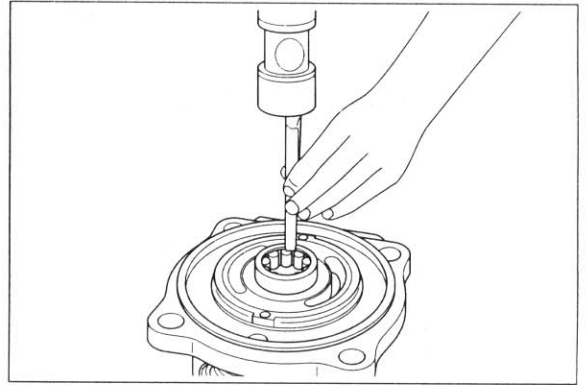

- (17) Reassemble valve plate(131) to the valve casing(303) and reassemble O-ring(472).

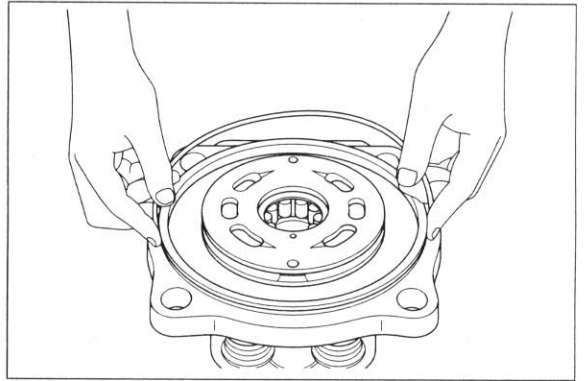

- (18) Connect the valve casing(303) with the casing(301) and tighten the hex socket bolt(401).

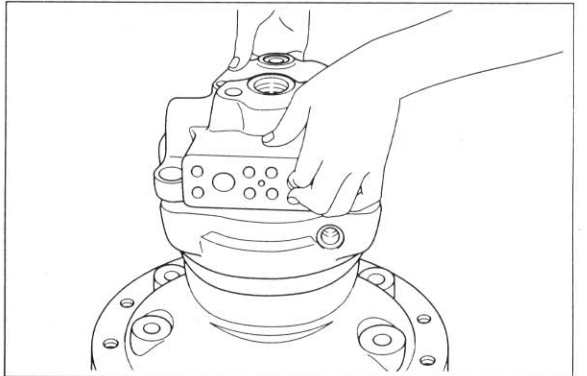

- (19) Insert plunger(351) and spring(355) in the valve casing and install O-ring(488).
Tighten RO plug(469) to the valve casing.

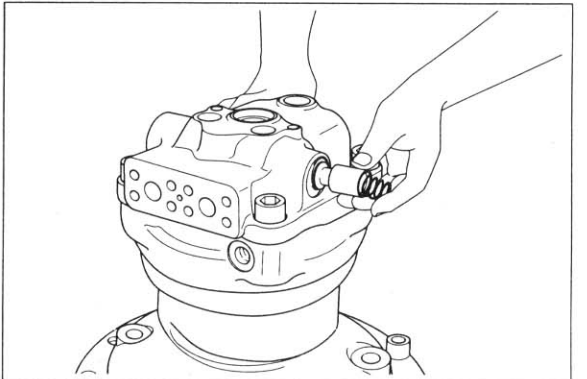

- (20) Insert back-up ring(162) and O-ring(161) to the relief valve(051), and reassemble them to valve casing(303).

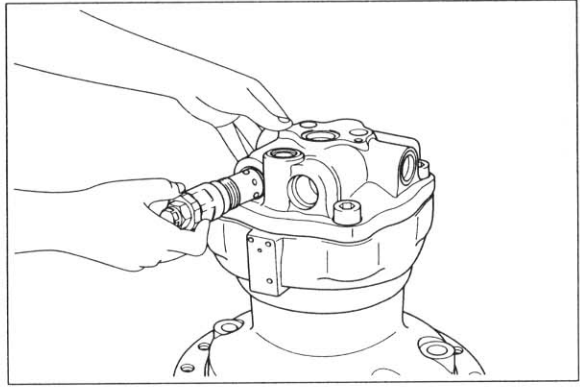

- (21) Tighten the plug(468) to valve casing(303) with O-ring(487) and tighten the plug(464) to casing(301) with O-ring(485).

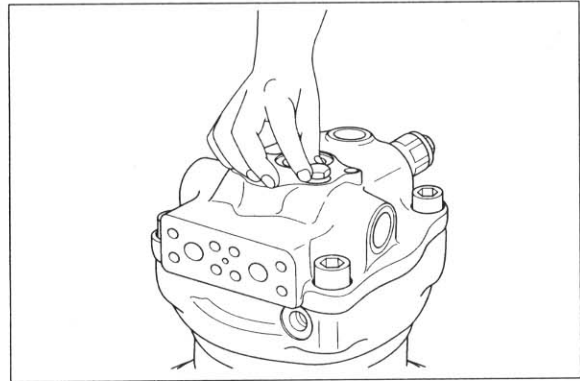

- (22) Connect the valve casing(303) with the casing(301).

This completes assembly.

3. REMOVAL AND INSTALL OF REDUCTION GEAR

1) REMOVAL

- (1) Remove the swing motor assembly.
For details, see **removal of swing motor assembly**
- (2) Slide reduction gear assembly(1) and remove mounting bolts(2)
- (3) Remove the reduction gear assembly
 - Reduction gear device weight :
260kg(573lb)



2) INSTALL

- (1) Carry out installation in the reverse order to removal.
 - Mounting bolt : 58.4kgf · m(422.4lb · ft)

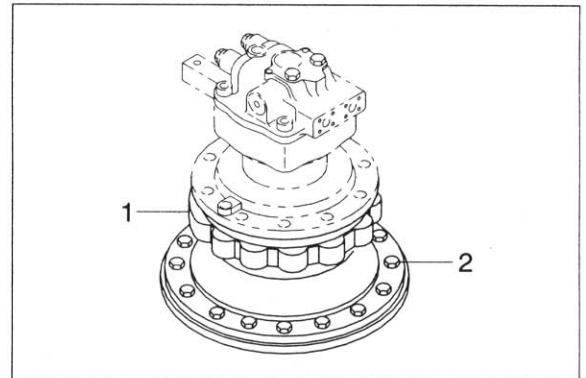

4. REDUCTION GEAR

1) STRUCTURE

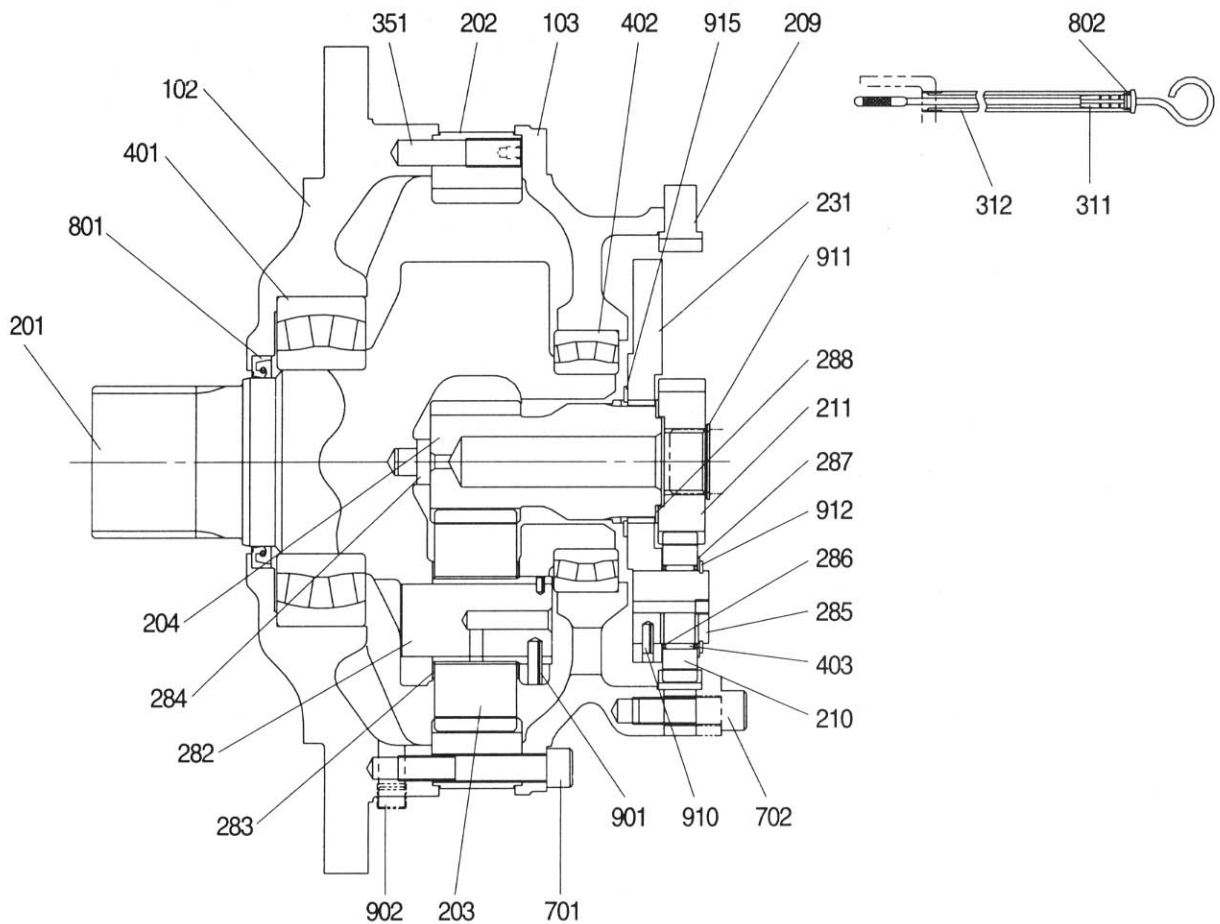

102	Front casing	283	Thrust washer	403	Needle gauge
103	Middle casing	284	Thrust button	701	Hex socket bolt
201	Shaft	285	Pin1	702	Hex socket bolt
202	Ring gear 2	286	Side plate	801	Oil seal
203	Planetary gear 2	287	Side plate	802	O - ring
204	Sun gear 2	288	Side plate	901	Spring pin
209	Ring gear 1	311	Level bar	902	plug
210	Planetary gear 1	312	Pipe	910	Spring pin
211	Sun gear 1	351	Lock pin	911	Stop ring
231	Carrier	401	Roller bearing	912	Stop ring
282	Pin	402	Roller bearing	915	Stop ring

2) Inspections

(1) Precautions

This assembly is designed to balance the life time of each part. Therefore, when replacing the parts, some parts could require another part's replacement at the same time because of their structural or functional correlations.

(2) Inspections replacement

- ① When the pitting happens on a tooth of sun gear, planetary gear or ring gear, replace the gear.(When a pit size is bigger than $\varnothing 1\text{mm}(0.04\text{'})$ or the pits are more than 5 percent of the tooth.)
- ② Replace the lock pin when loosely installed in the pin groove because of the wearing.
- ③ Replace the oil seal when damaged or wore. Replace the oil seal when reassembling the reduction gear assembly.
- ④ Replace the No.1 carrier assembly when flaking happens on the sliding surfaces of the No.1 planetary gear.
- ⑤ Replace the No.2 planetary gear assembly when radial clearance of bearing is more than $0.6\text{mm}(0.02\text{'})$.
Replace the No.2 planetary gear assembly when removing the output shaft.
- ⑥ Replace the thrust button when the sliding surface of the sun gear is badly damaged.
- ⑦ Replace the thrust washer only when it was damaged.
- ⑧ Replace the shaft support bearing when it was damaged. Do not reuse the disassemble shaft support bearing.
* Inspect the No.2 planetary gear, thrust button, thrust washer, and shaft support bearing as in assembly.

3) Disassembly.

- (1) Remove the level bar(311) and pipe(312) installed in the swing motor.
- (2) Loosen the drain plug in the swing gear box to discharge the gear oil.
* Check the gear oil for contamination.
- (3) Release the bolt(702) and remove the swing motor from is reduction gear assembly.
- (4) Release the No.1 sun gear(211).
- (5) Release the No.1 carrier assembly including No.1 planetary gear.
- (6) Disassemble the No.1 carrier assembly, if necessary.
- (7) Release the No.2 sun gear(204) and if necessary, remove the stop ring(915).
- (8) Remove the No.1 ring gear(209).
- (9) Remove the middle, casing(103).
- (10) Remove the output shaft(201) assembly.
- (11) Remove the No.2 ring gear(202) front the casing(102).
- (12) Remove the oil seal(801) from the front casing(102).
- (13) Remove the self-aligning roller bearing(402).
- (14) Remove the pin(282).
- (15) Remove the spring pin from the output shaft.
- (16) Remove the No.2 planetary gear(203) and thrust washer(283).
* Remove that the above articles(13~16) are applied for only special inspections or maintenance.

4) Assembly

- (1) Reassemble the output shaft assembly.
 - ① Install the self-aligning roller bearing(4010) in the output shaft(201) after warming it up for about 10 minutes in the oil can at 80°C ~ 100°C(176°F ~ 212°F).
 - ② Insert the thrust button(284) in the groove of the output shaft.
 - ③ Insert the thrust plate(283) of No.2 planetary gear(203) in the output shaft(201).
 - ④ Insert the pin(282) with spring(901) in the pin hole of output shaft.
- (2) Insert the oil seal(801) in the front casing(102).
- (3) Reassemble the output shaft assembly in the front casing(102).
- (4) Insert the 4 lock pins(351) in the front casing(102).
- (5) Reassemble the No.2 ring gear(202) after applying grease to the front casing(102).
- (6) Reassemble the middle casing(103) after applying grease to the No.2 ring gear.
- (7) Reassemble No.2 sun gear(204) with the stop ring(915).
- (8) Reassemble the No.1 ring gear(209) after applying grease to the middle casing(103).
- (9) Reassemble the No.1 carrier assembly.
 - ① Insert the No.1 pin(285)with the spring pin(910) in the No.1 carrier(231).
 - ② Insert the spring pin(910) in the No.1 carrier.
 - ③ Insert the side plate(288) in the center of No.1 carrier.
 - ④ Insert the side plate(286).
 - ⑤ Insert the side plate(287) with stop ring(912).

※ See the Table for the sizes of side plates.

Item no.	Inner dia.		Outer dia.		Thickness	
	mm	in	mm	in	mm	in
286	50	1.97	70	2.76	1	0.04
287	50	1.97	70	2.76	2	0.79
288	60	2.36	83	3.35	2	0.79

- (10) Install the No.1 carrier assembly in the No.2 sun gear.
- (11) Install the No.1 sun gear(211).
- (12) Install the swing motor with stop ring(911) in the No.1 ring gear(209) with grease.
- (13) Insert the pin(902) in the drain plug of the gear.
- (14) Reassemble the level bar(311) and pipe(312).
- (15) Give gear oil.

This completes assembly.