

GROUP 3 PILOT CIRCUIT

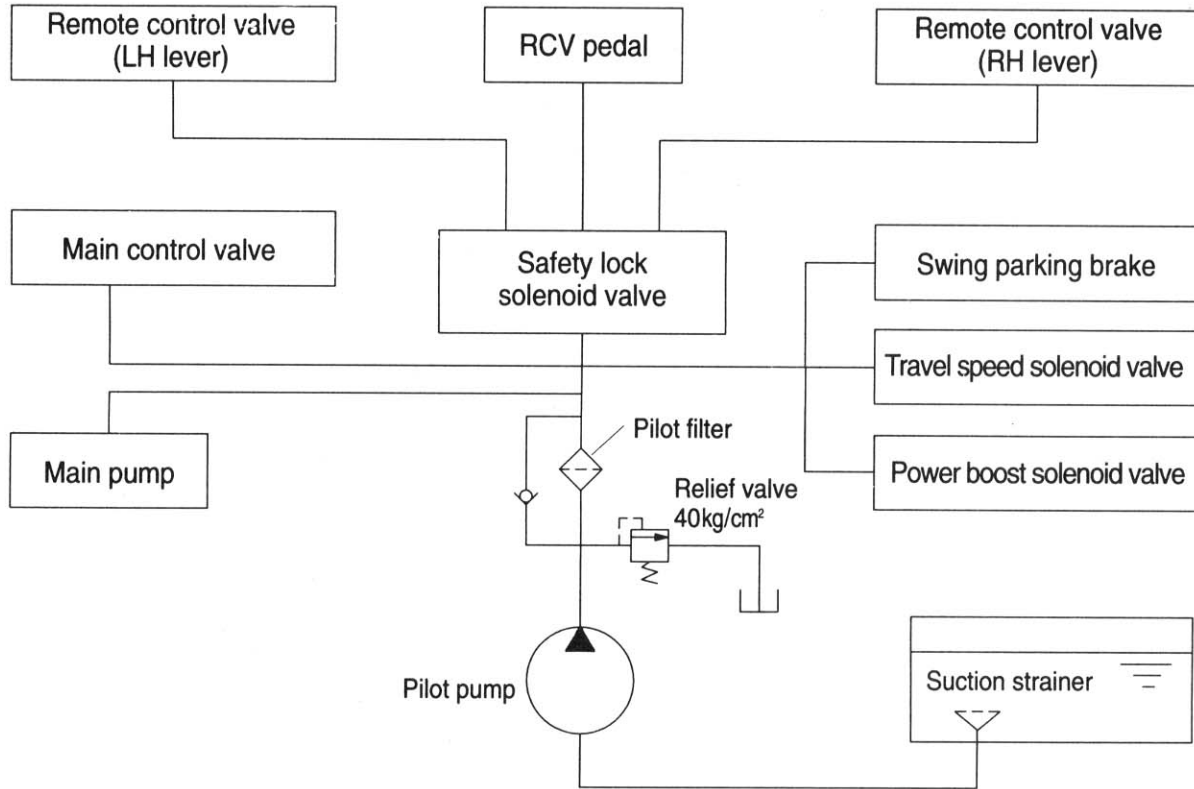

The pilot circuit consists of suction circuit, delivery circuit and return circuit.

The pilot pump is provided with a relief valve, receives the oil from the hydraulic tank through the suction strainer.

The discharged oil from the pilot pump flows to the remote control valve through the pilot filter, EPPR valve, travel speed solenoid valve, swing parking brake, main control valve and safety lock solenoid valve.

1. SUCTION, DELIVERY AND RETURN CIRCUIT

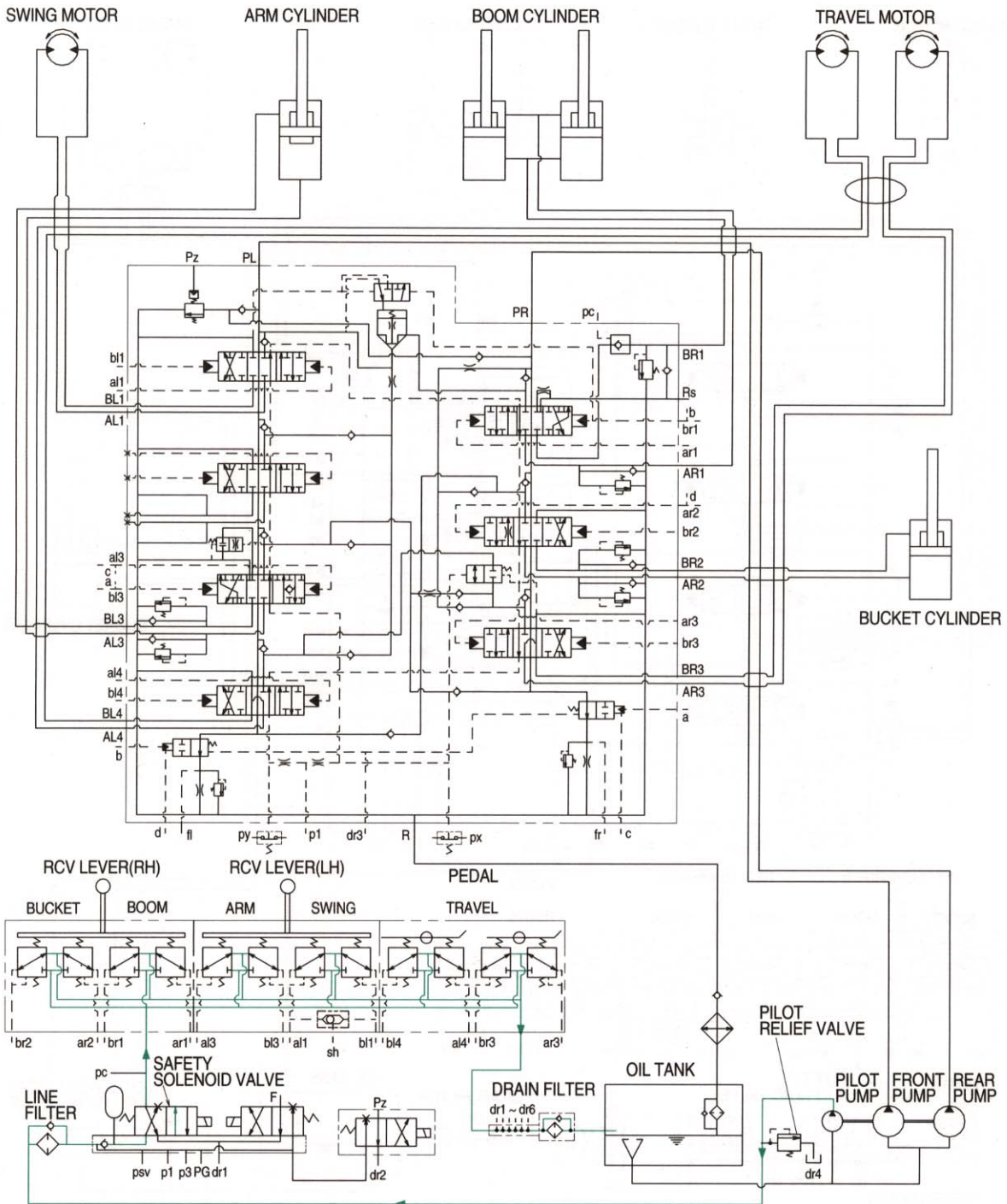

The pilot pump receive oil from the hydraulic tank. The discharged oil from the pilot pump flows to the safety solenoid valve through the line filter. The oil is filtered by the pilot filter in the line filter. The pilot relief valve is provided in the pilot pump for limiting the pilot circuit pressure. The oil filtered by pilot filter flows remote control valve through safety solenoid valve. The return oil returned to hydraulic tank through the remote control valve.

2. SAFETY SOLENOID VALVE (SAFETY LEVER)

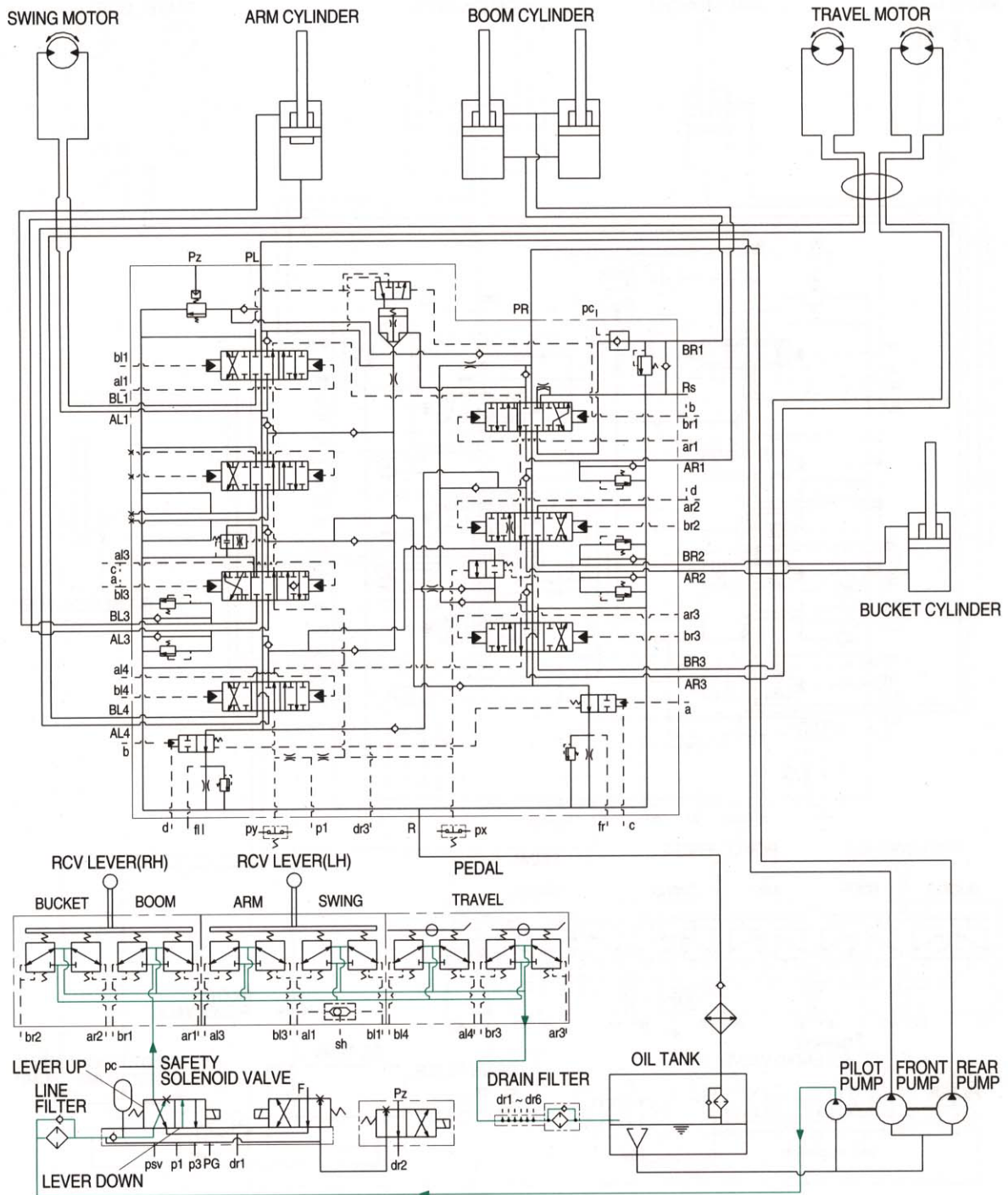

When the lever of the safety solenoid valve moved downward, oil flow remote control valve through solenoid valve and line filter.

When the lever of the safety solenoid valve moved upward, oil does not flow remote control valve, because of blocked by the spool.

3. MAIN RELIEF PRESSURE CHANGE CIRCUIT

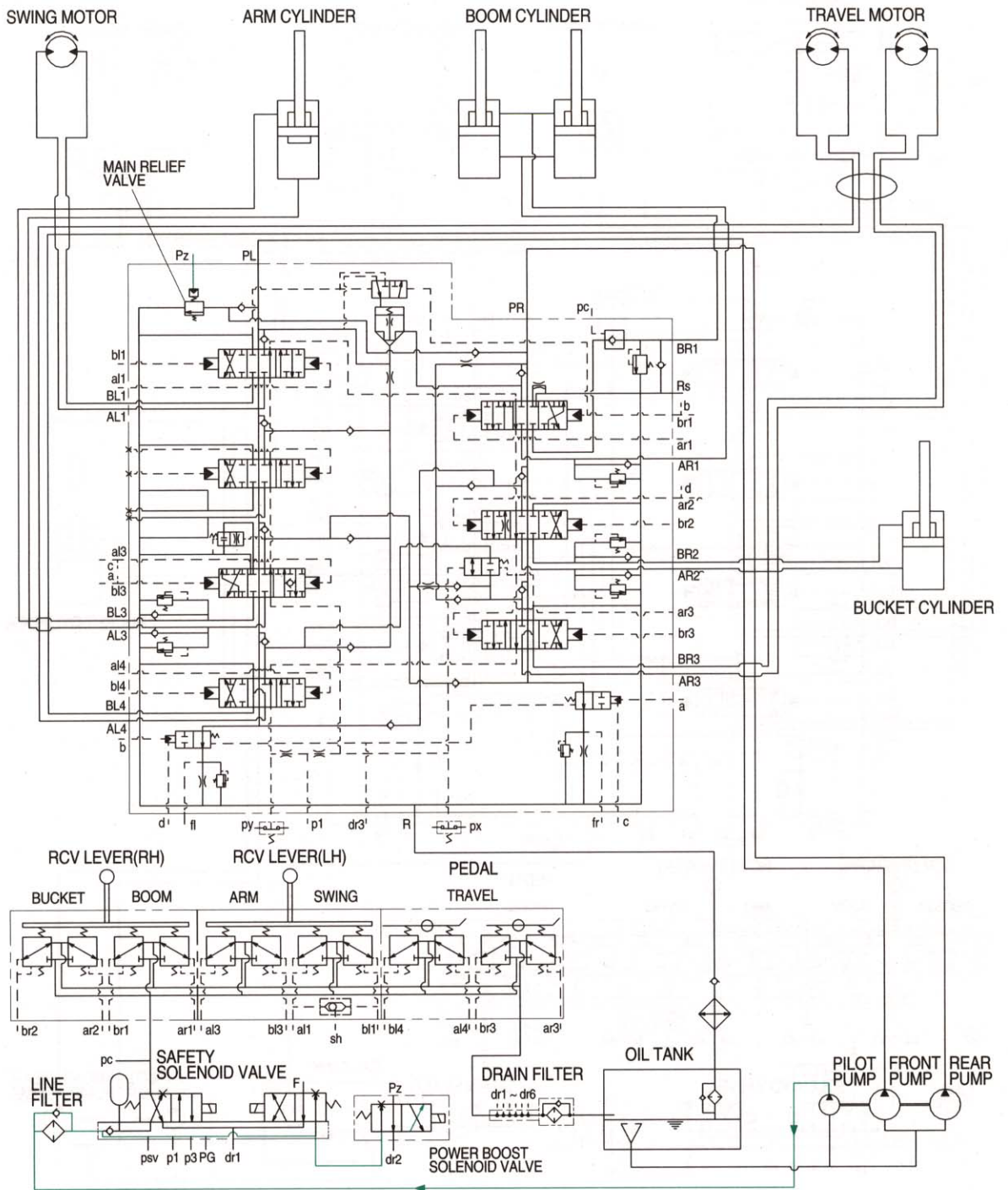

When the power boost switch keeps pressed, the main relief valve pressure changes from 320kg/cm² to 350kg/cm² for maximum 8 seconds.

4. SWING PARKING BRAKE RELEASE

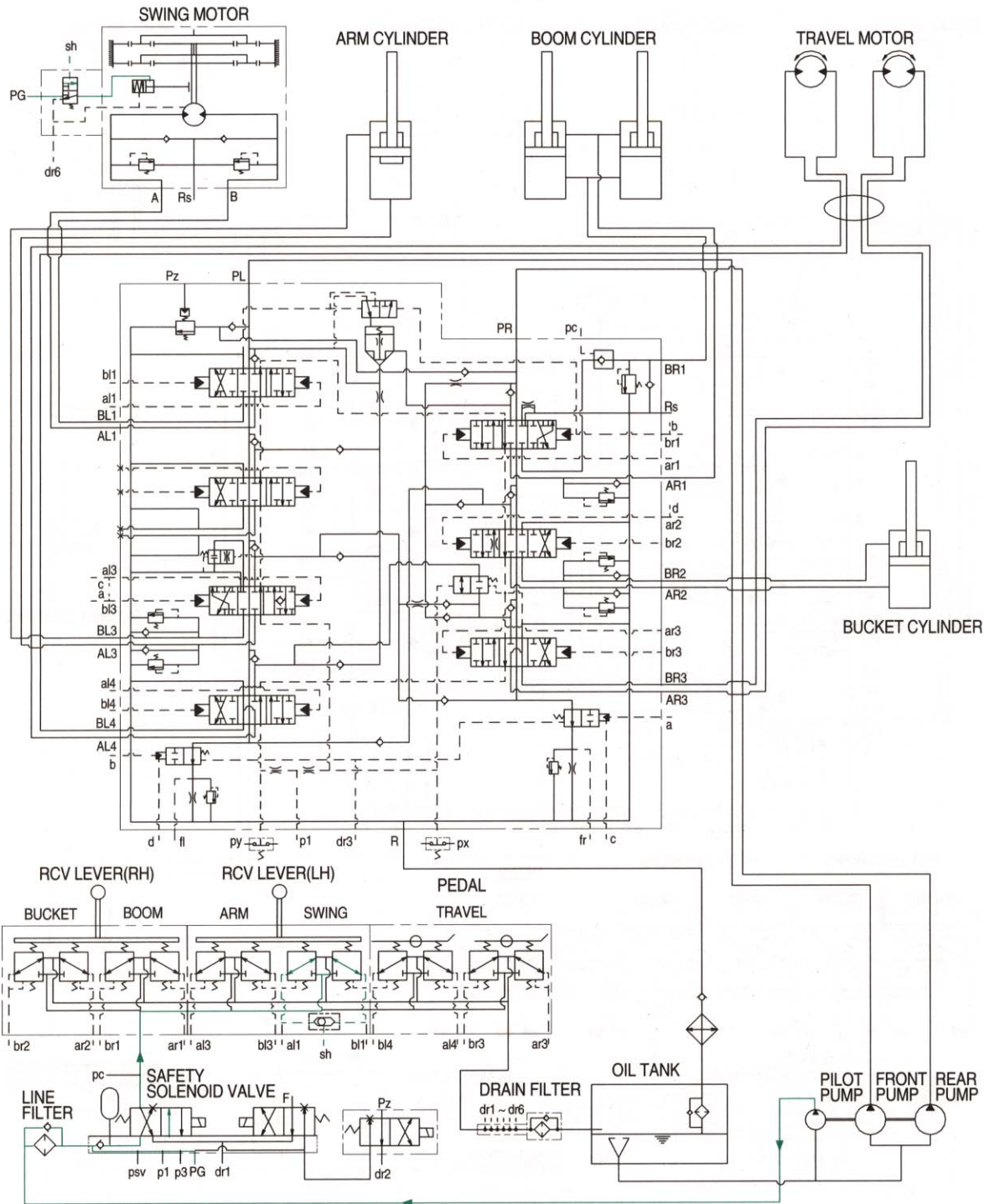

When the swing control lever is tilted, the pilot oil go to **sh** port of shuttle valve, this pressure move spool so, discharged oil from pilot pump go to PG port.

This pressure is applied to swing motor disc cylinder, thus the brake released.

When the swing control lever is set neutral position, oil in the motor disc cylinder is drain, thus the brake works.

5. TRAVEL SPEED CONTROL PRESSURE

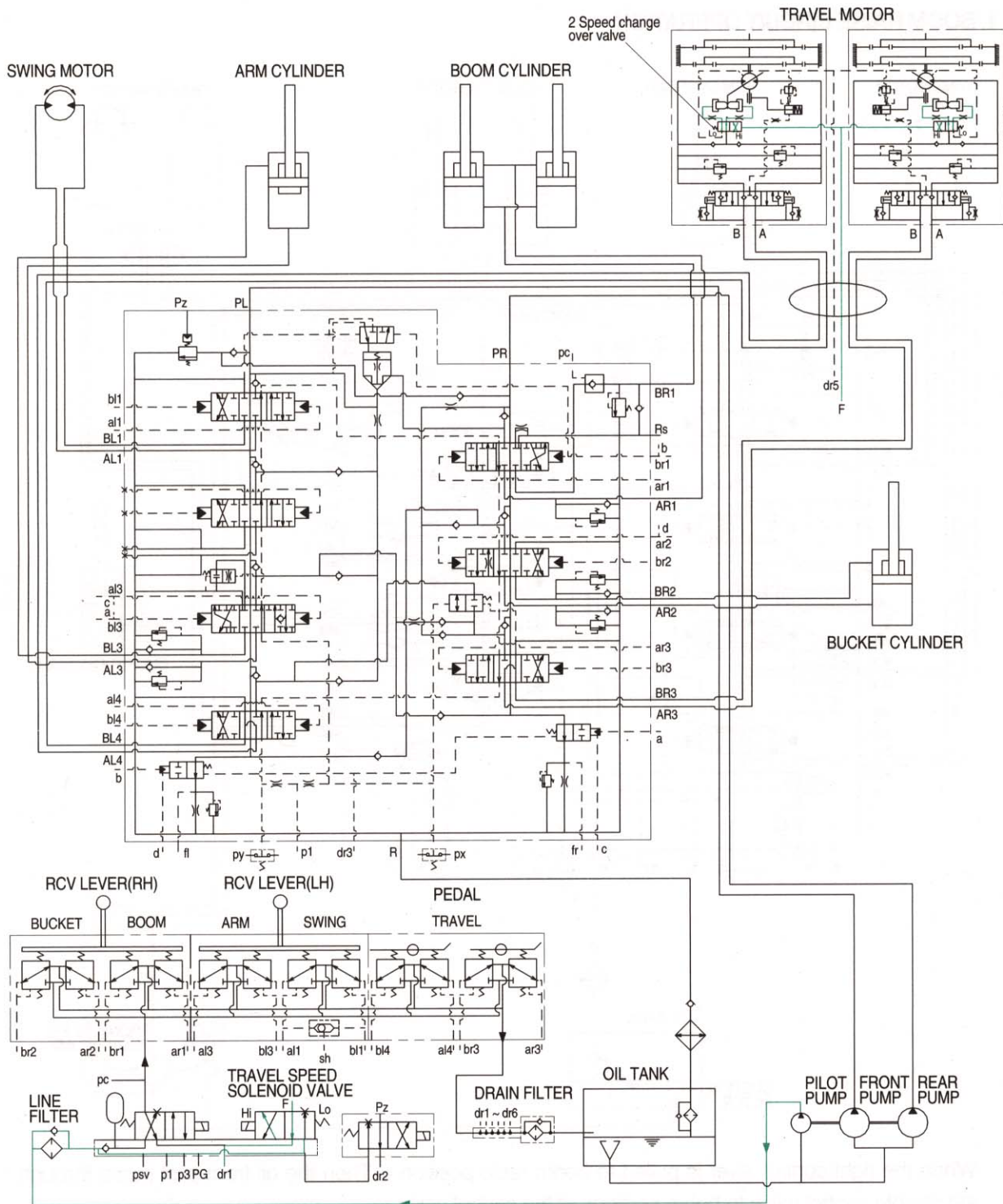

When the travel speed solenoid valve was placed in the Hi position, the pressure oil from pilot pump flows to F port of 2 speed change over valve, and the control piston is pushed Hi position, thus minimizing the displacement.

When the travel speed solenoid valve was placed in the Lo position, the oil of F port return to the tank and the control piston is returned, thus maximizing the displacement.