

GROUP 5 ELECTRICAL SYSTEM BY HYPER DAT

1. WHEN STARTING SWITCH IS TURNED ON, MONITOR PANEL DISPLAY DOES NOT APPEAR

- Before using the HYPER DAT make sure you understand the user's guide of HYPER DAT.
- Before mounting or dismounting the HYPER DAT, always turn the starting switch OFF.
- Before starting switch turn ON or OFF, check all related connectors are properly inserted.

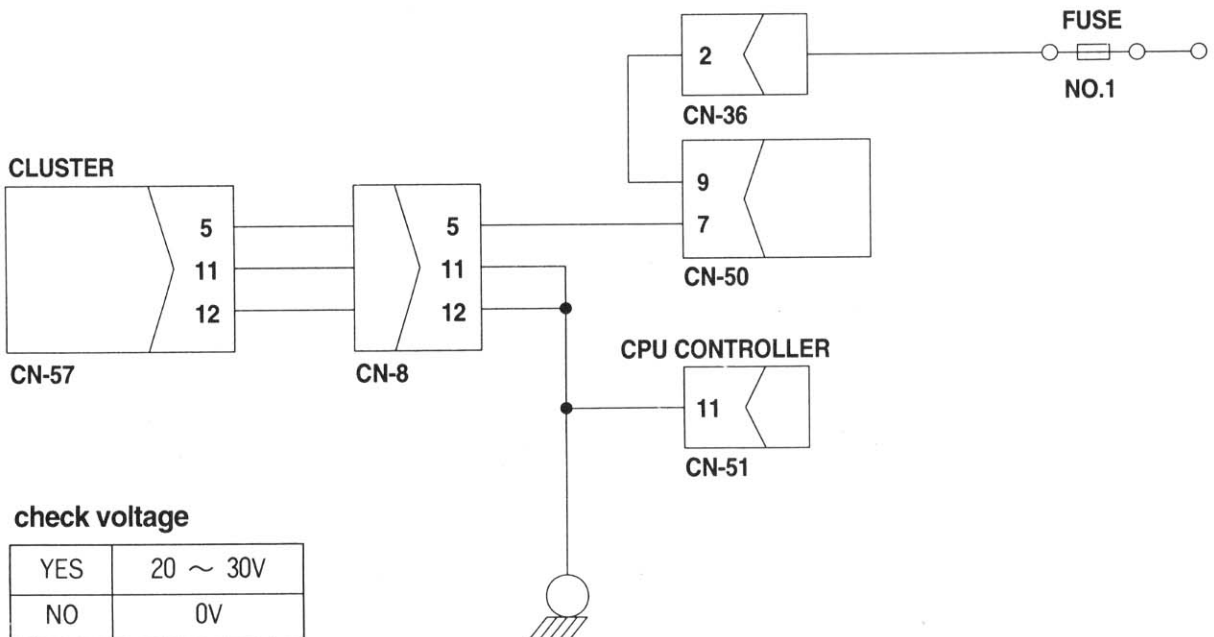
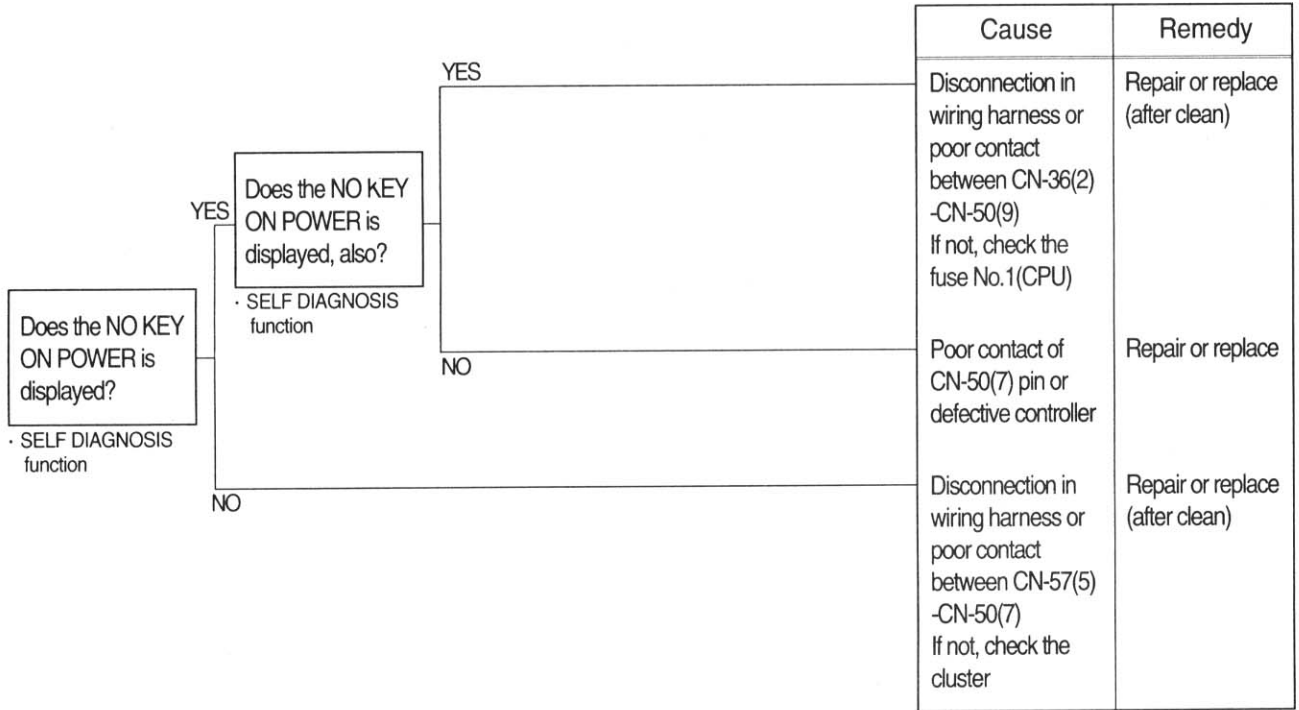

2. BATTERY CHARGING LAMP LIGHTS UP (Engine is started)

- Before using the HYPER DAT make sure you understand the user's guide of HYPER DAT.
- Before mounting or dismounting the HYPER DAT, always turn the starting switch OFF.
- Before starting switch turn ON or OFF, check all related connectors are properly inserted.

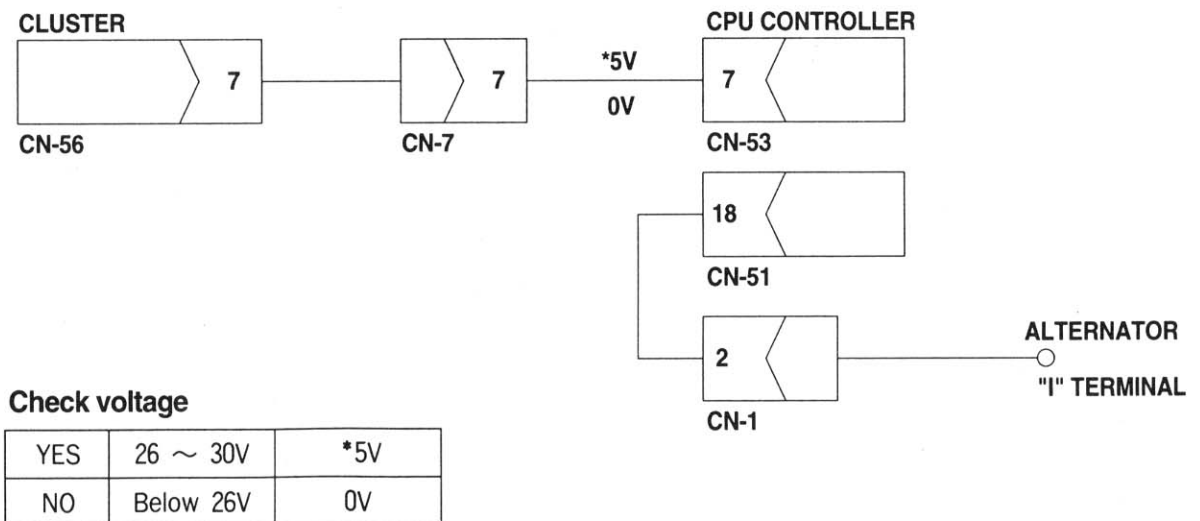
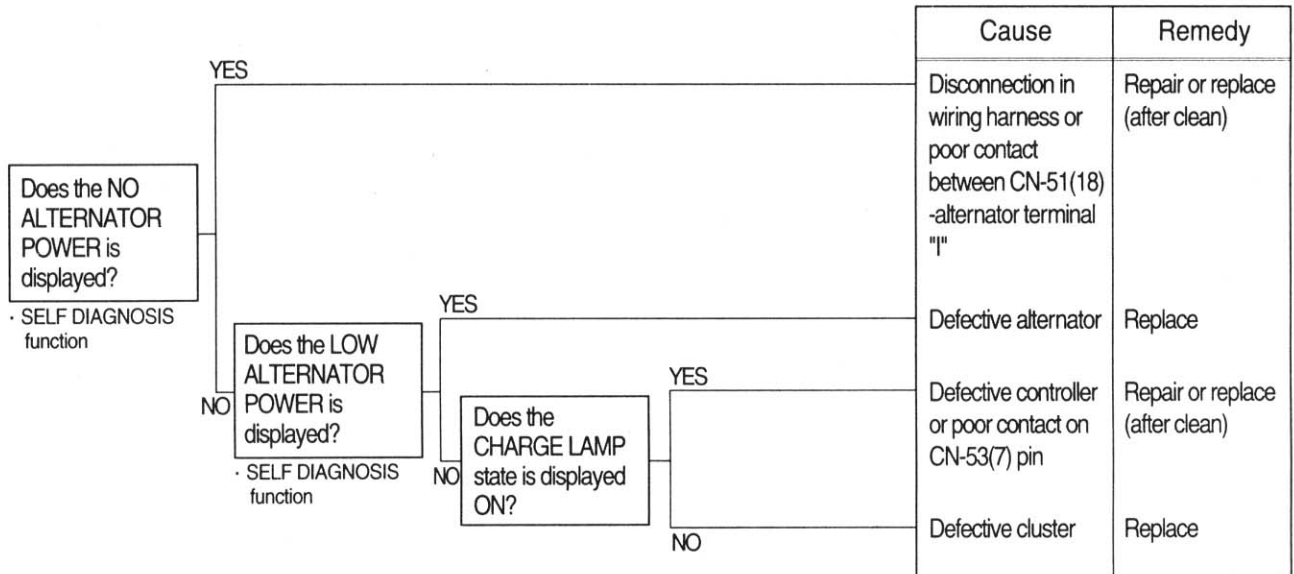

3. WHEN COOLANT OVERHEAT LAMP LIGHTS UP(Engine is started)

- Before using the HYPER DAT make sure you understand the user's guide of HYPER DAT.
- Before mounting or dismounting the HYPER DAT, always turn the starting switch OFF.
- Before starting switch turn ON or OFF, check all related connectors are properly inserted.

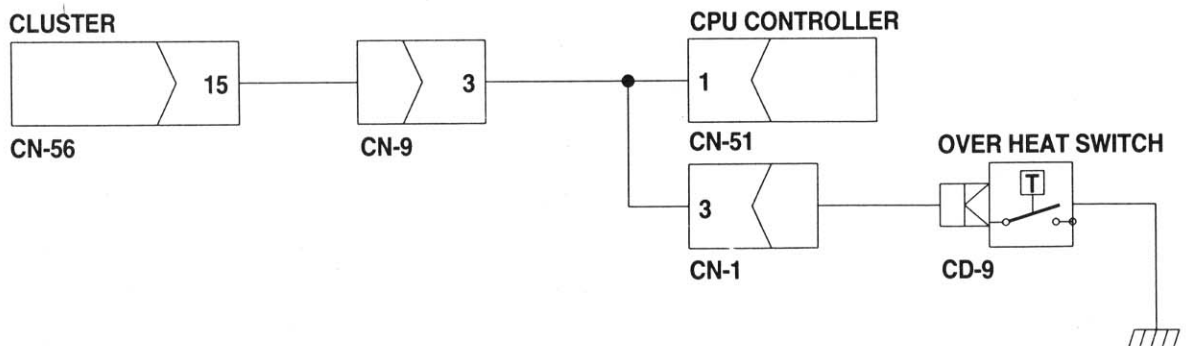
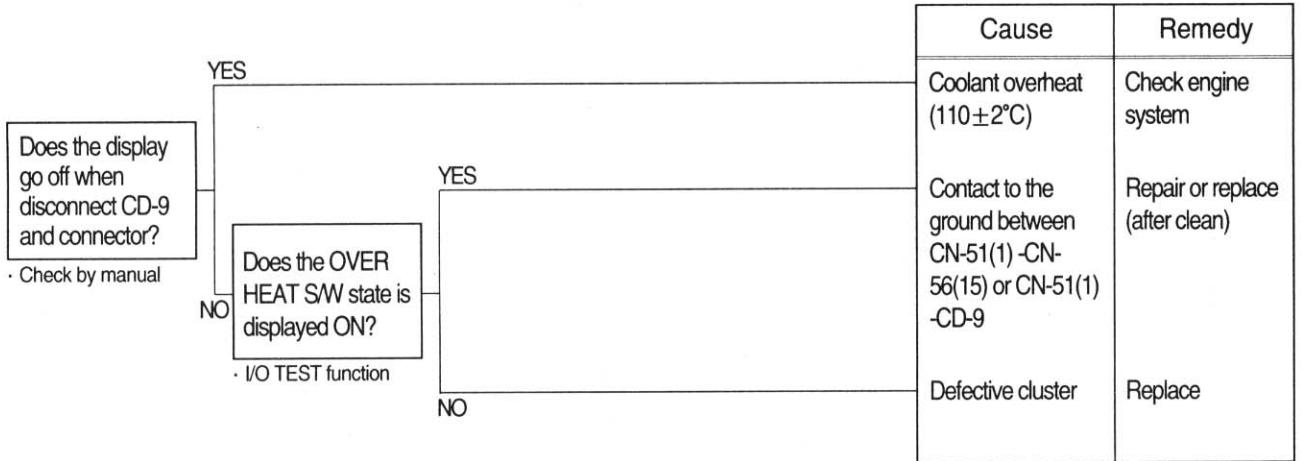

Check resistance

YES	MAX 1 Ω
NO	MIN 1 MΩ

4. WHEN HYDRAULIC OIL TEMPERATURE LAMP LIGHTS UP(Engine is started)

- Before using the HYPER DAT make sure you understand the user's guide of HYPER DAT.
- Before mounting or dismounting the HYPER DAT, always turn the starting switch OFF.
- Before starting switch turn ON or OFF, check all related connectors are properly inserted.

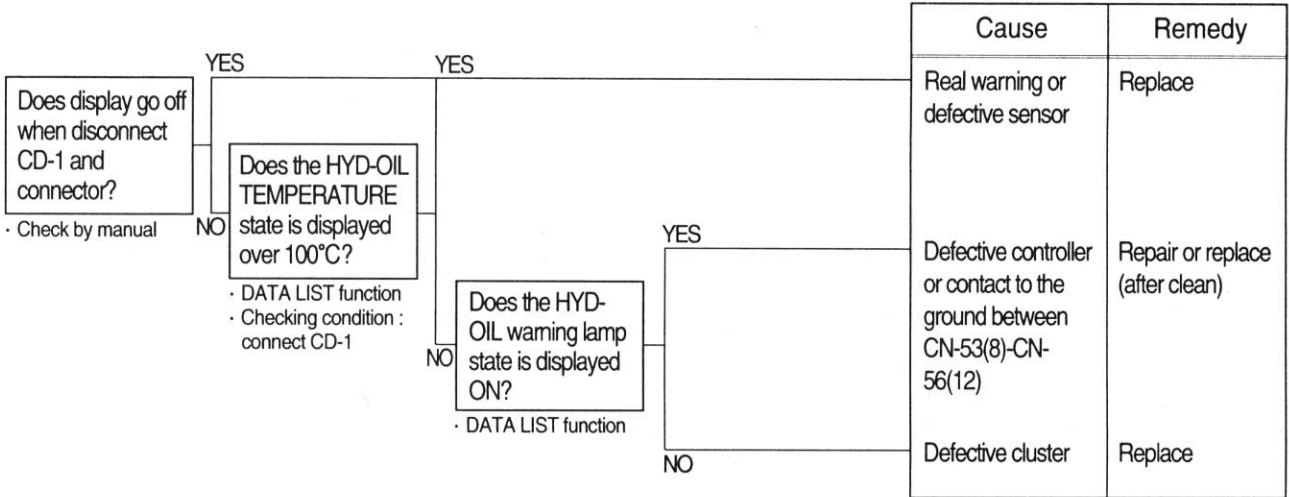

Check resistance

YES	MAX 1 Ω
NO	MIN 1 MΩ

HYDRAULIC OIL TEMPERATURE SENDER

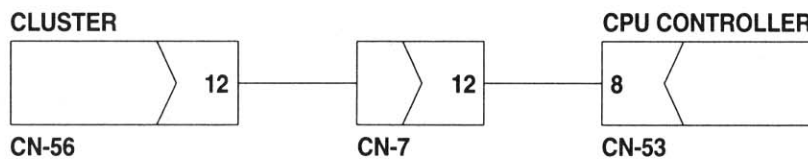
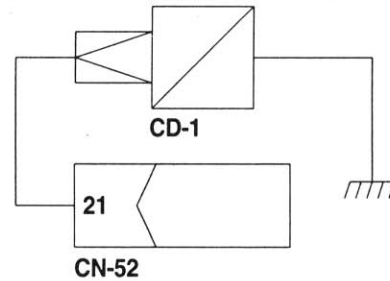

5. WHEN TRAVEL SPEED 1, 2 DOES NOT OPERATE

- Before using the HYPER DAT make sure you understand the user's guide of HYPER DAT.
- Before mounting or dismounting the HYPER DAT, always turn the starting switch OFF.
- Before starting switch turn ON or OFF, check all related connectors are properly inserted.

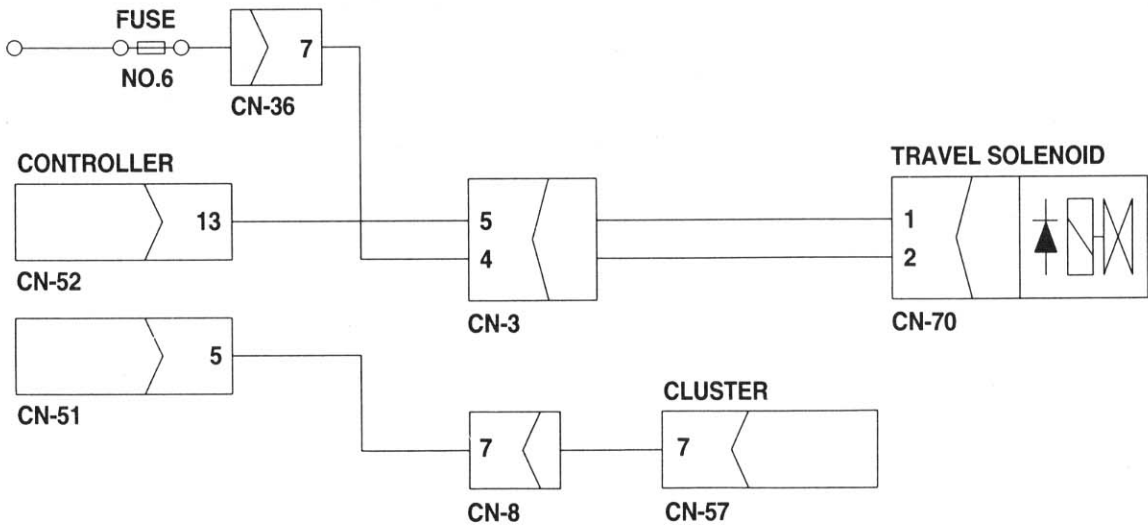
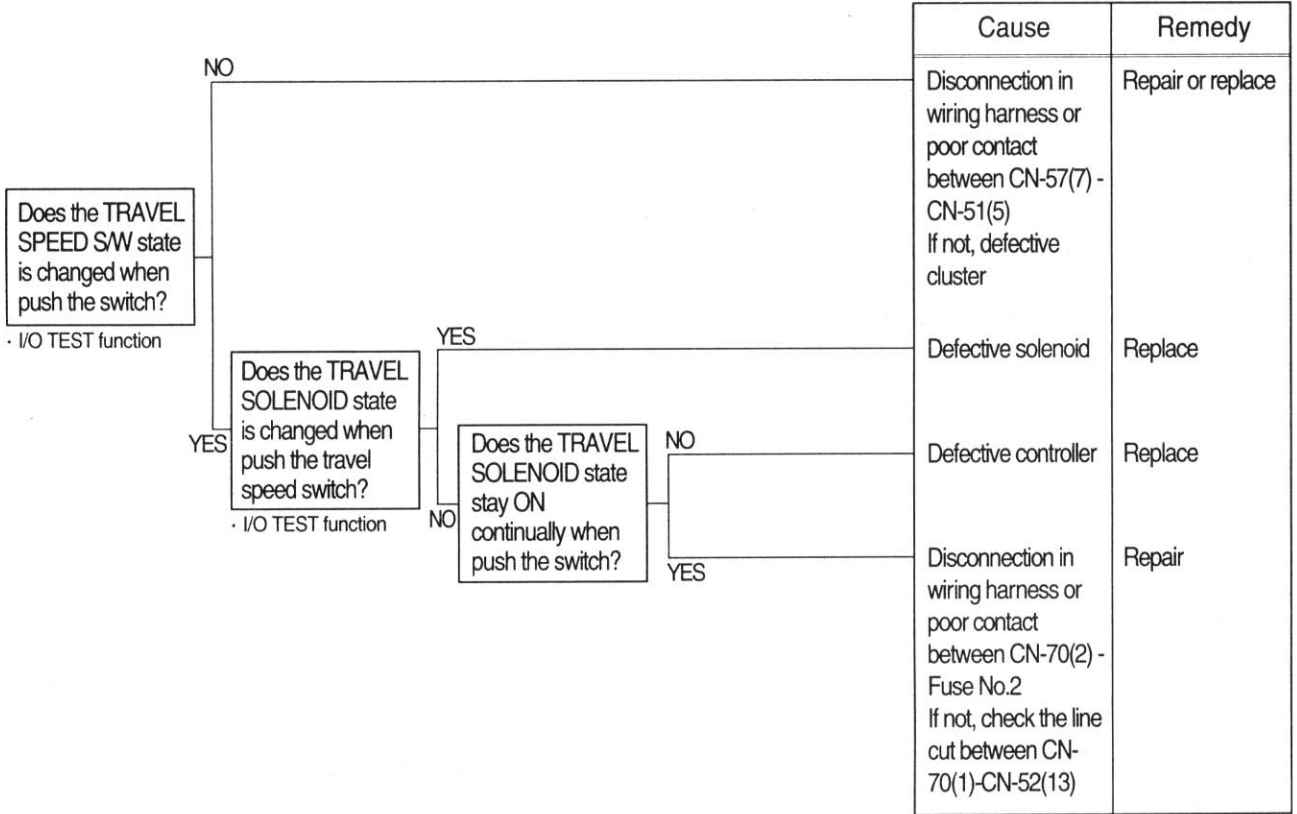

6. ENGINE DOES NOT STOP, WHEN TURN THE START KEY OFF

- Before using the HYPER DAT make sure you understand the user's guide of HYPER DAT.
- Before mounting or dismounting the HYPER DAT, always turn the starting switch OFF.
- Before starting switch turn ON or OFF, check all related connectors are properly inserted.

	Cause	Remedy
YES	Defective fuel cut-off solenoid	Replace
NO	Defective start key switch or the line, between CN-79(1)-CS-2(3), is contacted to the power wire harness	Check and repair

Does the NO KEY ON POWER is displayed when turn the start key off?

· SELF DIAGNOSIS function

