

## GROUP 2 MAJOR COMPONENT

### 1. MAIN PUMP

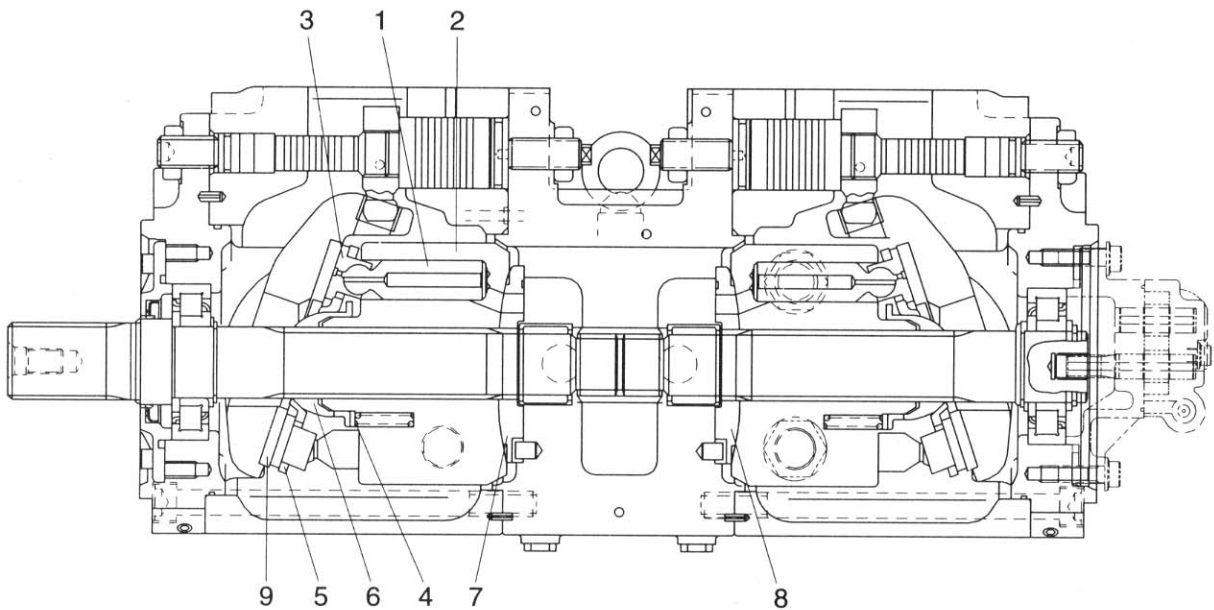

Part name & inspection item		Standard dimension	Recommended replacement value	Countermeasures
Clearance between piston(1) & cylinder bore(2) (D-d)		0.038	0.078	Replace piston or cylinder.
Play between piston(1) & shoe caulking section(3) ( $\delta$ )		0-0.1	0.35	Replace assembly of piston & shoe.
Thickness of shoe (t)		5.4	5.0	
Free height of cylinder spring(4) (L)		40.9	40.1	Replace cylinder spring.
Combined height of set plate(5) & spherical bushing(6) (H-h)		13.5	12.5	Replace retainer or set plate.
Surface roughness for valve plate(sliding face)(7,8), swash plate (shoe plate area)(9), & cylinder(2)(sliding face)	Surface roughness necessary to be corrected	3z		Lapping
	Standard surface roughness (corrected value)	0.4z or lower		

## 2. MAIN CONTROL VALVE

Part name	Inspection item	Remedy
Casing	<ul style="list-style-type: none"> <li>Scratch, rust and corrosion</li> </ul>	<ul style="list-style-type: none"> <li>Replace parts that have damage on the following areas:               <ul style="list-style-type: none"> <li>Sliding surface between casing hole and spool, particularly the land area.</li> <li>Seal pocket section into which spool enters.</li> <li>Sealing area to which O-ring contact.</li> <li>Sealing area of main, travel and port relief valves.</li> <li>Other areas which may be deemed to mar normal functions.</li> </ul> </li> </ul>
Spool	<ul style="list-style-type: none"> <li>Scratch, binding, rust and corrosion</li> <li>O-ring seals on both ends</li> <li>Insert spool into casing hole, rotate and stroke it.</li> </ul>	<ul style="list-style-type: none"> <li>Replace a spool with a scratch that may be caught by your nail (particularly on an area in contact with seals).</li> <li>Replace such a spool having a scratch on its sliding surface.</li> <li>Correct or replace such a spool that may damage O-rings or that does it operate smoothly.</li> </ul>
Poppet	<ul style="list-style-type: none"> <li>Damage of poppet and spring</li> <li>Insert poppet into casing and function it.</li> </ul>	<ul style="list-style-type: none"> <li>Correct or replace such a poppet that gives incomplete sealing effect.</li> <li>Poppet is normal if it functions lightly without binding.</li> </ul>
Spring and associated parts	<ul style="list-style-type: none"> <li>Inspect that spring, spring seat, plugs and covers are not rusted, corroded, deformed and broken.</li> </ul>	<ul style="list-style-type: none"> <li>Replace those showing excessive damage.</li> </ul>
Spool seal and related areas	<ul style="list-style-type: none"> <li>Oil leakage to outside</li> <li>Rusting, corrosion and deformation of seal plate</li> </ul>	<ul style="list-style-type: none"> <li>Correct or replace.</li> <li>Correct or replace.</li> </ul>
Relief valve	<ul style="list-style-type: none"> <li>External rusting and damage</li> <li>Contact surface of valve seat</li> <li>Contact surface of poppet</li> <li>Fault on springs</li> <li>O-rings, backup rings and seals</li> </ul>	<ul style="list-style-type: none"> <li>Replace.</li> <li>Replace one that is damaged.</li> <li>Replace one that is damaged.</li> <li>Replace.</li> <li>Replace all as a rule.</li> </ul>

### 3. SWING DEVICE

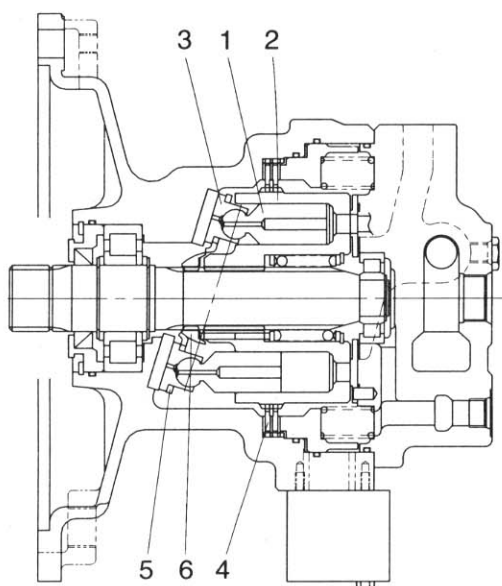

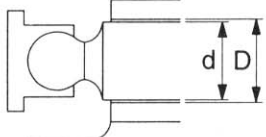
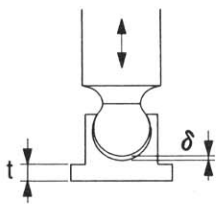
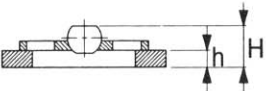
Part name & inspection item		Standard dimension	Recommended replacement value	Countermeasures
Clearance between piston(1) & cylinder bore(2) (D-d)		0.028	0.058	Replace piston or cylinder.
Play between piston(1) & shoe caulking section(3) ( $\delta$ )		0	3	Replace assembly of piston & shoe.
Thickness of shoe (t)		5.5	5.3	
Thickness of friction plate(T)	-	4.0	3.6	Replace cylinder friction plate.
Combined height of set plate(5) & spherical bushing(6) (H-h)		6.5	12.5	Replace retainer or set plate.

#### 4. TRAVEL MOTOR

Replace parts in accordance with the following standards. However, if a part is damaged significantly in terms of its appearance, replace it irrespective of the standards.

##### 1) HYDRAULIC MOTOR

Part name & inspection item	Standard dimension	Recommended value for replacement	Remedy
Clearance between piston & cylinder bore	0.044 mm	0.065 mm	Replacement
Clearance caulked part between piston and shoe	0.1 mm	0.3 mm	Replacement
Thickness of shoe	5.5 mm	5.3 mm	Replacement
Assembled height of spherical bush and set plate	13.5 mm	13.0 mm	Replacement as a set
Free length of cylinder spring	47.9 mm	47.3 mm	Replacement
Shaft over pin dia. Output spline Cylinder spline	43.91(ø 4.5) 49.06(ø 4.5)	43.31 mm 48.46 mm	Replacement if either one reaches replacement value.
Spline over dia. Spline in cylinder Spline in spherical bush	35.25(ø 5)	35.75 mm	Replacement
Thickness of separator plate Thickness of friction plate	2.3 mm 3.2 mm	2.1 mm 3.0 mm	Replacement
Free length of brake spring	46.6 mm	45.9 mm	Replacement
Displacement over teeth Over pin dia. of friction plate internal teeth	49.97(7teeth) 145.89(ø 4.5)	49.37 mm 146.49 mm	Replacement Replacement
Roughness of sliding surfaces Swash plate/shoe Cylinder block/valve plate Swash plate/its supporter Set plate/spherical bus	0.4 z 0.4 z 6.3 z 1.6 z	3 z 3 z 12.5 z 6.3 z	Each independent lapping Mutual lapping Mutual lapping Mutual lapping
Roller bearing Needle bearing	-	-	Replacement if flaking is found on rolling surface
O-ring Oil seal	-	-	Replacement at every disassembly, in principle

Part name & inspection item	Standard dimension	Recommended value for replacement	Remedy
Screw	-	-	Replacement if elongation is found.
Piston ring	-	-	Replacement if such abnormality as seizure, deformation, etc, is found.

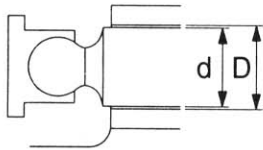

clearance between piston and cylinder bore :  $D-d$

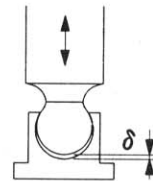

Play at caulking between piston and shoe :  $\delta$

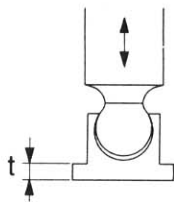

Thickness of shoe :  $t$

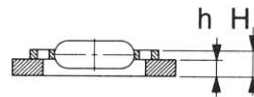

Assembled height of set plate and spherical bush :  $H-h$

## 2) REDUCTION GEAR

Part name & inspection item		Standard dimension	Recommended value for replacement	Remedy
Pitting or crack of gear		-	Pitting area rate : 10%	Replacement pitting or crack is found
Motor driving gear external spline		Overpin 43.91( $\phi$ 4.5)	43.31 mm	(Z=14)
No. 1 sun gear internal spline		Overpin 30.25( $\phi$ 5)	30.85 mm	Replacement (Z=14)
Reduction ratio $i = 67.57$	No. 1 sun gear	Displacement 42.90(4teeth)	42.60 mm	Do. (Z=28)
	No. 1 planetary gear	Displacement 43.58(4teeth)	43.28 mm	Do. (Z=24)
	Ring gear(1st stage)	Overpin 301.84( $\phi$ 7)	302.44 mm	Do. (Z=77)
No. 1 carrier internal spline		Overpin 92.13( $\phi$ 10)	92.73 mm	Do. (Z=21)
No. 2 sun gear		Displacement 39.87(3teeth)	39.57 mm	Do. (Z=21)
No. 2 planetary gear		Displacement 55.01(4teeth)	54.71 mm	Do. (Z=26)
No. 2 carrier internal spline		Overpin 112.24( $\phi$ 10)	112.84 mm	Do. (Z=25)
No. 3 sun gear		Displacement 40.16(3teeth)	39.86 mm	Do. (Z=25)
No. 3 planetary gear		Displacement 40.09(3teeth)	39.76 mm	Do. (Z=24)
No. 3 carrier internal spline		Overpin 157.53( $\phi$ 5.486)	158.13 mm	Do. (Z=52)
Casing external spline		Overpin 174.48( $\phi$ 6.096)	173.88 mm	Replacement. (Z=52)
Ring gears (2nd & 3rd stages)		Overpin 372.59( $\phi$ 7.2)	373.19 mm	Do. (Z=75)
Crack and flaking of bearing inner/outer races and rollers		-	-	Replacement if crack or flaking is found.
Crack and flaking of 1st/2nd/3rd planetary and pins		-	-	Do.

Part name & inspection item	Standard dimension	Recommended value for replacement	Remedy
Radial clearance of needle bearing	0.01-0.04 mm	0.07 mm	Replacement of abnormal parts as a set.
Crack of spline coupling area	-	-	Replacement if such damage as crack, crevice of chipping is found.
Backlash of spline coupling	0.1-0.3 mm	0.5 mm	Dimension check and replacement according to following standards.
Thrust ring(024)	7 mm thick	6.6 mm	Replacement if severe wear or seizure is found on sliding surface.
Thrust ring(025)	5.8 mm thick	5.4 mm	
Thrust ring(026)	7.8 mm thick	7.4 mm	
Floating seal	-	-	Replacement of scratch or rust is found in sliding surface. Replacement if O-ring is deformed or damaged.
Gear oil	Shall Spirax 90EP or equivalent to SAE # 90 API Service Classification GL-4	-	1st time : 500hr 2nd time and later : Every 2000hr After disassembling, fill with new oil without fail. { The above time are measured with engine hour meter. }

## 5. RCV LEVER

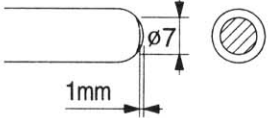
Maintenance check item	Criteria	Remark
Leakage	The valve is to be replaced when the leakage becomes more than 1000cc/m at neutral handle position, or more than 2000cc/m during operation.	Conditions : Primary pressure : 30kgf/cm <sup>2</sup> Oil viscosity : 23cSt
Spool	This is to be replaced when the sliding surface has worn more than 10 $\mu$ m, compared with the non-sliding surface.	The leakage at the left condition is estimated to be nearly equal to the above leakage.
Push rod	 <p>This is to be replaced when the top end has worn more than 1mm.</p>	
Play at operating section	The pin, shaft, and joint of the operating section are to be replaced when their plays become more than 2mm due to wears or so on.	When a play is due to looseness of a tightened section, adjust it.
Operation stability	When abnormal noises, hunting, primary pressure drop, etc. are generated during operation, and these cannot be remedied, referring to section 6. troubleshooting, replace the related parts.	

- Notes
1. It is desirable to replace seal materials, such as O-rings, every disassembling. However, they may be reused, after being confirmed to be free of damage.
  2. When loosening the hexagon socket head cap screw(125), replace the seal washers(121) without fail.

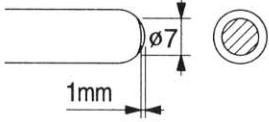

## 6. RCV PEDAL

Maintenance check item	Criteria	Remark
Leakage	The valve is to be replaced when the leakage effect to the system. For example, the primary pressure drop.	Conditions : Primary pressure : 30kgf/cm <sup>2</sup> Oil viscosity : 23cSt
Spool	This is to be replaced when the sliding surface has worn more than 10 $\mu$ m, compared with the non-sliding surface.	The leakage at the left condition is estimated to be nearly equal to the above leakage.
Push rod	 <p>This is to be replaced when the top end has worn more than 1mm.</p>	
Play at operating section	The pin, shaft, and joint of the operating section are to be replaced when their plays become more than 2mm due to wears or so on.	When a play is due to looseness of a tightened section, adjust it.
Operation stability	When abnormal noises, hunting, primary pressure drop, etc. are generated during operation, and these cannot be remedied, referring to section 6 troubleshooting, replace the related parts.	

Notes 1. It is desirable to replace seal materials, such as O-rings, every disassembling. However, they may be reused, after being confirmed to be free of damage.

## 7. TURNING JOINT

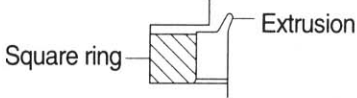
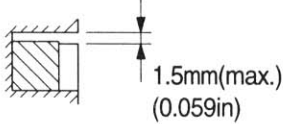
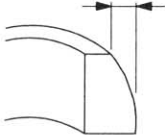
Part name		Maintenance standards	Remedy
Body, Stem	Sliding surface with sealing sections.	Plating worn or peeled due to seizure or contamination.	Replace
	Sliding surface between body and stem other than sealing section.	· Worn abnormality or damaged more than 0.1mm (0.0039in) in depth due to seizure contamination.	Replace
		· Damaged more than 0.1mm(0.0039in) in depth.	Smooth with oilstone.
	Sliding surface with thrust plate.	· Worn more than 0.5mm(0.02in) or abnormality.	Replace
		· Worn less than 0.5mm(0.02in).	Smooth
		· Damage due to seizure or contamination remediable within wear limit (0.5mm) (0.02in).	Smooth
Cover	Sliding surface with thrust plate.	· Worn more than 0.5mm (0.02in) or abnormality.	Replace
		· Worn less than 0.5mm (0.02in).	Smooth
		· Damage due to seizure or contamination remediable within wear limit (0.5mm) (0.02in).	
Seal set		· Extruded excessively from seal groove square ring.	Replace
			
		· Slipper ring 1.5mm(0.059in) narrower than seal groove, or narrower than back ring.	Replace
			
		· Worn more than 0.5mm(0.02in) ~ 1.5mm(MAX.) (0.059in)	Replace
			

## 8. CYLINDER

Part name	Inspecting section	Inspection item	Remedy
Piston rod	· Neck of rod pin	· Presence of crack	· Replace
	· Weld on rod hub	· Presence of crack	· Replace
	· Stepped part to which piston is attached.	· Presence of crack	· Replace
	· Threads	· Presence of crack	· Recondition or replace
	· Plated surface	· Plating is not worn off to base metal · Rust is not present on plating. · Scratches are not present.	· Replace or replate. · Replace or replate · Recondition, replate or replace
	· Rod	· Wear of outer diameter	· Recondition, replate or replace
Cylinder tube	· Bushing at mounting part	· Wear of inner diameter	· Replace
	· Weld on bottom	· Presence of crack	· Replace
	· Weld on head	· Presence of crack	· Replace
	· Weld on hub	· Presence of crack	· Replace
	· Tube interior	· Presence of faults	· Replace if oil leak is seen
Cylinder head	· Bushing at mounting part	· Wear on inner surface	· Replace
	· Bushing	· Wear on inner surface · Flaw on inner surface	· Replace · Replace if flaw is deeper than coating