

## GROUP 9 BOOM, ARM AND BUCKET CYLINDER

### 1. REMOVAL AND INSTALL

#### 1) BUCKET CYLINDER

##### (1) Removal

- ※ Expand the arm and bucket fully, lower the work equipment to the ground and stop the engine.
- ※ Loosen the breather slowly to release the pressure inside the hydraulic tank.
- ▲ Escaping fluid under pressure can penetrate the skin causing serious injury.
- ※ Fit blind plugs in the hoses after disconnecting them, to prevent dirt or dust from entering.

① Set block between bucket cylinder and arm.

- ② Remove nut(3), bolt(2) and pull out pin(1).
- ※ Tie the rod with wire to prevent it from coming out.

③ Disconnect bucket cylinder hoses(4) and put plugs on cylinder pipe.

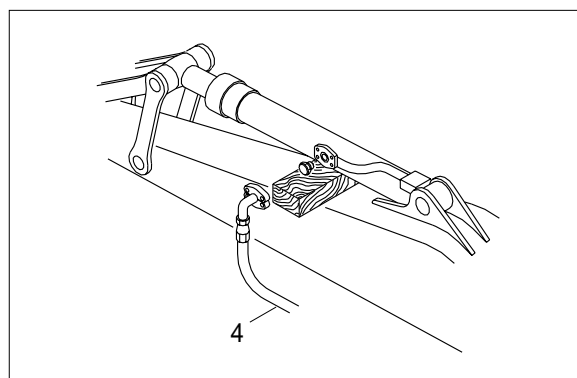
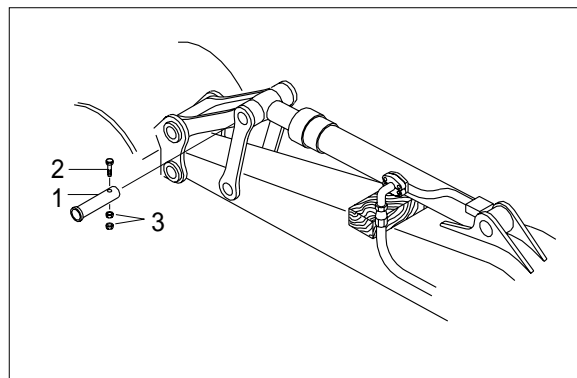
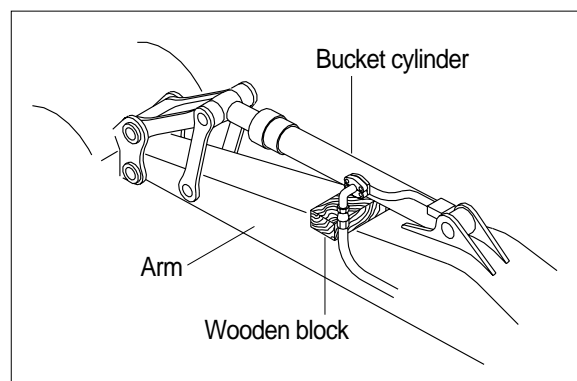

- ④ Sling bucket cylinder assembly, and remove bolt(6), nut(7) then pull out pin(5). Remove bucket cylinder assembly(8)
- ⑤ · Weight : 268kg(591lb)

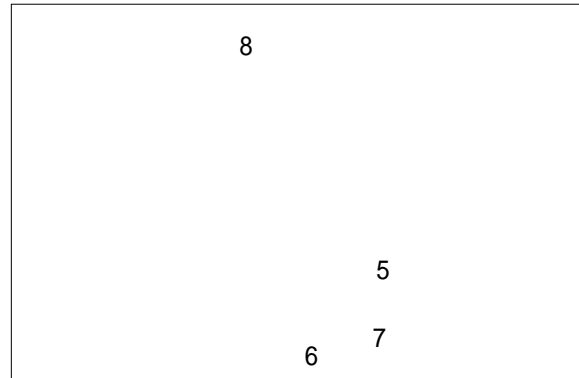

## (2) Install

- ① Carry out installation in the reverse order to removal.
- ▲ When aligning the mounting position of the pin, do not insert your fingers in the pin hole.
- ※ Bleed the air from the bucket cylinder.
- ※ Confirmed the hydraulic oil level and check the hydraulic oil leak or not.

## 2) ARM CYLINDER

### (1) Removal

- ※ Expand the arm and bucket fully, lower the work equipment to the ground and stop the engine.
- ※ Loosen the breather slowly to release the pressure inside the hydraulic tank.
- ▲ Escaping fluid under pressure can penetrate the skin causing serious injury.
- ※ Fit blind plugs in the hoses after disconnecting them, to prevent dirt or dust from entering.

① Set block between arm cylinder and boom.

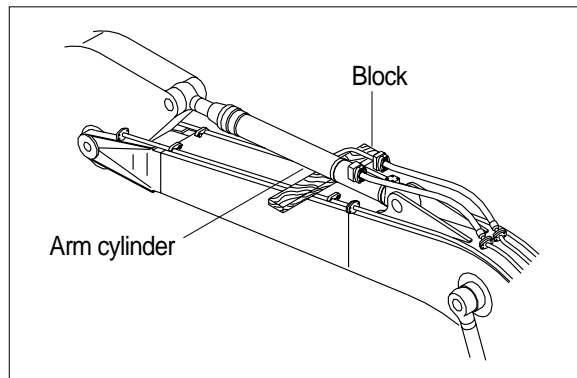

- ② Remove bolt(2), nut(3) and pull out pin(1).
- ※ Tie the rod with wire to prevent it from coming out.



- ③ Disconnect arm cylinder hoses(4) and put plugs on cylinder pipe.
- ④ Disconnect greasing hoses(5).

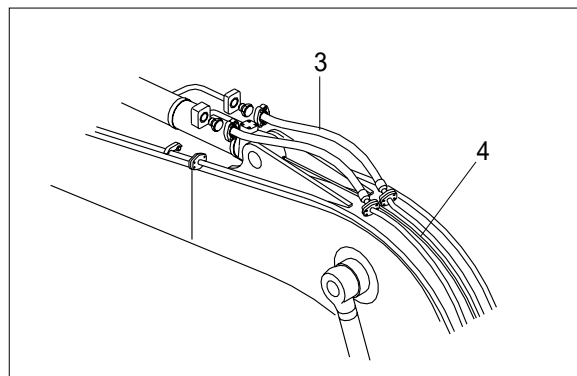

- ⑤ Sling bucket arm assembly(9), and remove bolt(7), nut(8) then pull out pin(6).
- ⑥ Remove arm cylinder assembly(9)
  - Weight : 485 kg(1069lb)

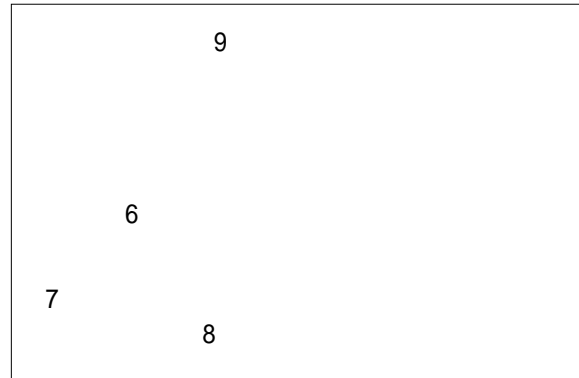

## (2) Install

- ① Carry out installation in the reverse order to removal.
- ▲ When aligning the mounting position of the pin, do not insert your fingers in the pin hole.
- ※ Bleed the air from the arm cylinder.
- ※ Confirmed the hydraulic oil level and check the hydraulic oil leak or not.

### 3) BOOM CYLINDER

#### (1) Removal

- ※ Expand the arm and bucket fully, lower the work equipment to the ground and stop the engine.
- ※ Loosen the breather slowly to release the pressure inside the hydraulic tank.
- ▲ Escaping fluid under pressure can penetrate the skin causing serious injury.
- ※ Fit blind plugs in the hoses after disconnecting them, to prevent dirt or dust from entering.

- ① Disconnect greasing hoses(1).
- ② Sling boom cylinder assembly.

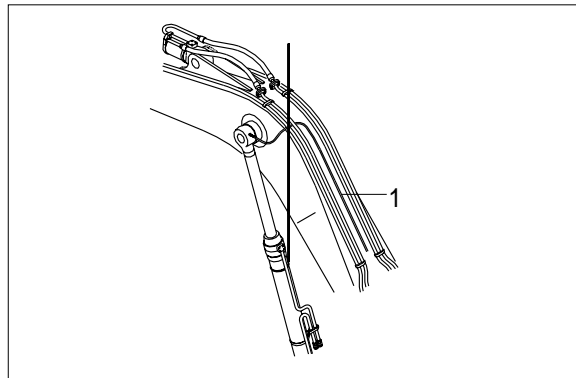

- ③ Remove nut(4), spring(3), pin stopper(5) and pull out pin(2).
- ※ Tie the rod with wire to prevent it from coming out.

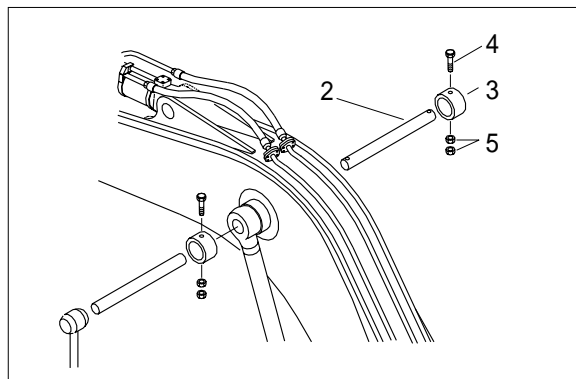

- ④ Lower the boom cylinder assembly(6) on a stand

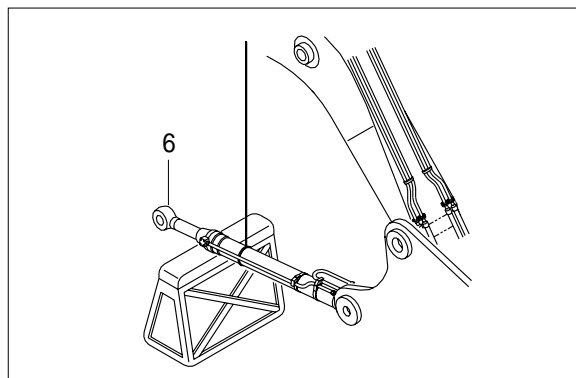

- ⑤ Disconnect boom cylinder hoses(7), and put plugs on cylinder pipe.

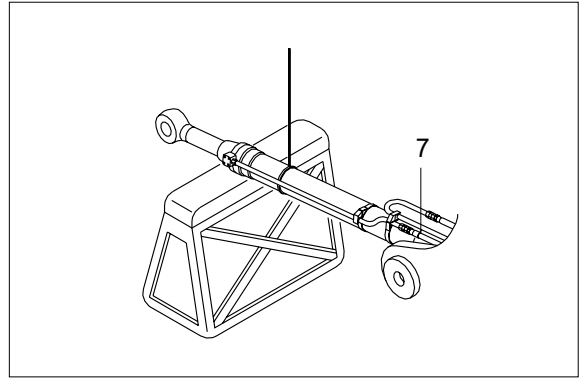

- ⑥ Remove bolt(9), plate(10) then pull out pin(8).  
⑦ Remove boom cylinder assembly(6)  
· Weight : 293kg(646lb)

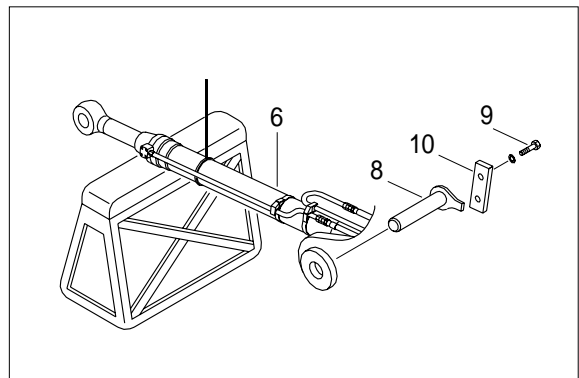

## (2) Install

- ① Carry out installation in the reverse order to removal.
- ⚠ When aligning the mounting position of the pin, do not insert your fingers in the pin hole.
- ※ Bleed the air from the boom cylinder.
  - ※ Confirmed the hydraulic oil level and check the hydraulic oil leak or not.

## 2. DISASSEMBLY AND ASSEMBLY

### 1) STRUCTURE

#### (1) Bucket cylinder

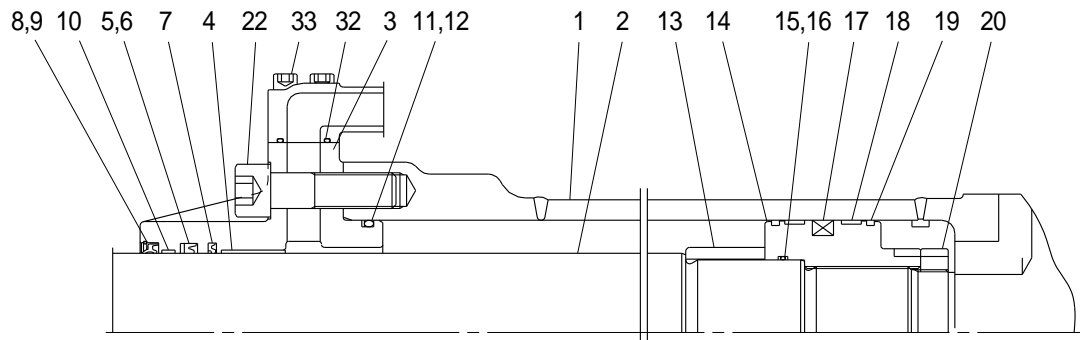

Internal detail

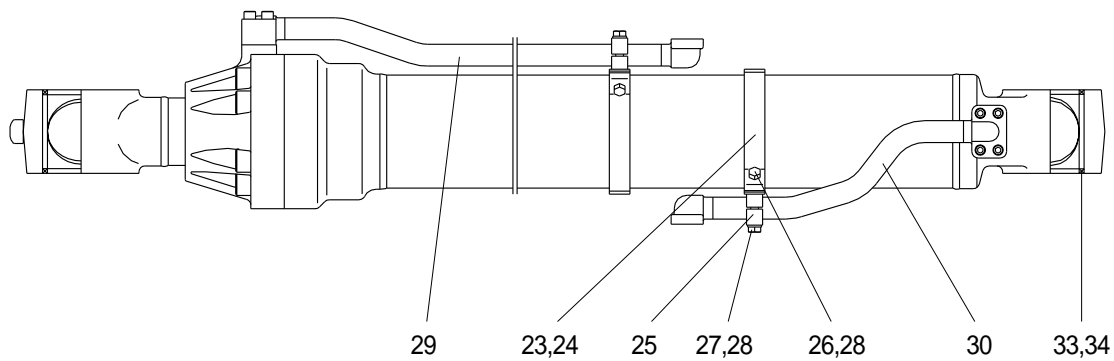

1	Tube assembly	13	Cushion ring	26	Spring washer
2	Rod assembly	14	Piston	27	U-bolt
3	Gland	15	O-ring	28	Hexagon nut
4	Du bushing	16	Back up ring	29	Spring washer
5	Rod seal	17	Piston seal	30	Pipe assembly(B)
6	Back up ring	18	Wear ring	31	Pipe assembly(R)
7	Buffer ring	19	Dust ring	32	O-ring
8	Dust wiper	20	Lock nut	33	Hexagon socket head bolt
9	Snap ring	22	Hexagon socket head bolt	34	Pin bushing
10	Wear ring	23	Band assembly	35	Dust seal
11	O-ring	24	Band		
12	Back up ring	25	Hexagon bolt		

## (2) Arm cylinder

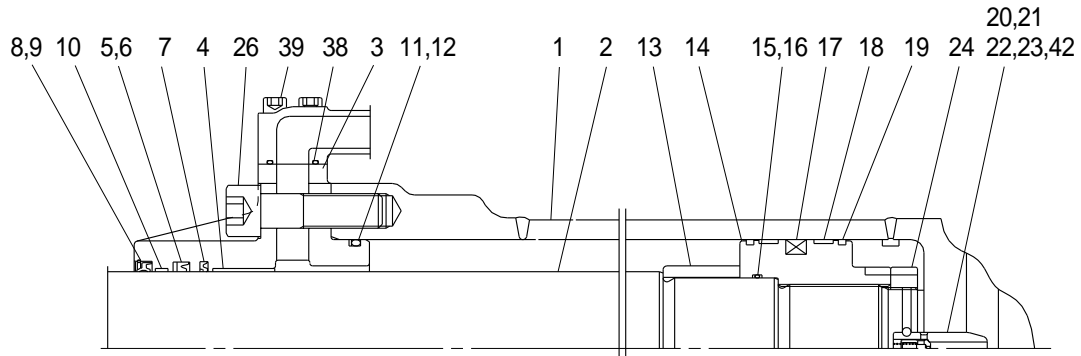

Internal detail

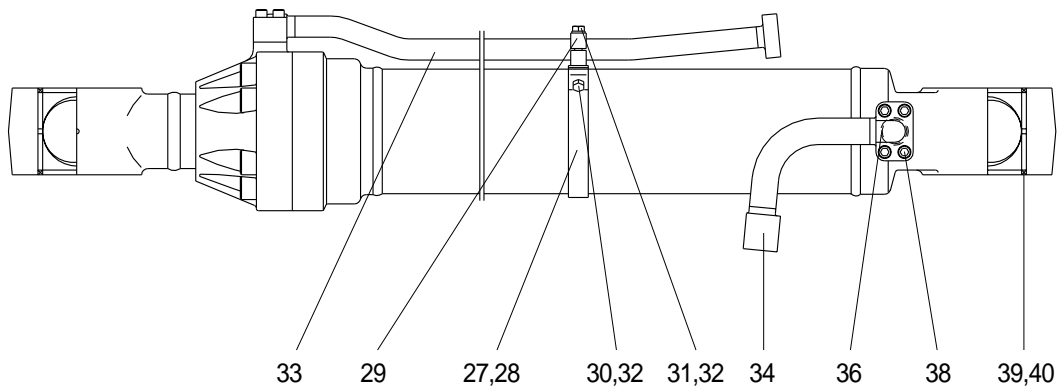

1	Tube assembly	15	O-ring	30	Band(R)
2	Rod assembly	16	Back up ring	31	Hexagon bolt
3	Gland	17	Piston seal	32	Spring washer
4	Du bushing	18	Wear ring	33	U-bolt
5	Rod seal	19	Dust ring	34	Hexagon nut
6	Back up ring	20	Cushion spear	35	Spring washer
7	Buffer ring	21	Check valve	36	Pipe assembly(B)
8	Dust wiper	22	Spring	37	Pipe assembly(R)
9	Snap ring	23	Steel ball	38	O-ring
10	Wear ring	24	Lock nut	39	Hexagon socket head bolt
11	O-ring	26	Hexagon socket head bolt	40	Pin bushing
12	Back up ring	27	Band assembly(B)	41	Dust seal
13	Cushion ring	28	Band(B)	42	Set screw
14	Piston	29	Band assembly(R)		



### (3) Boom cylinder

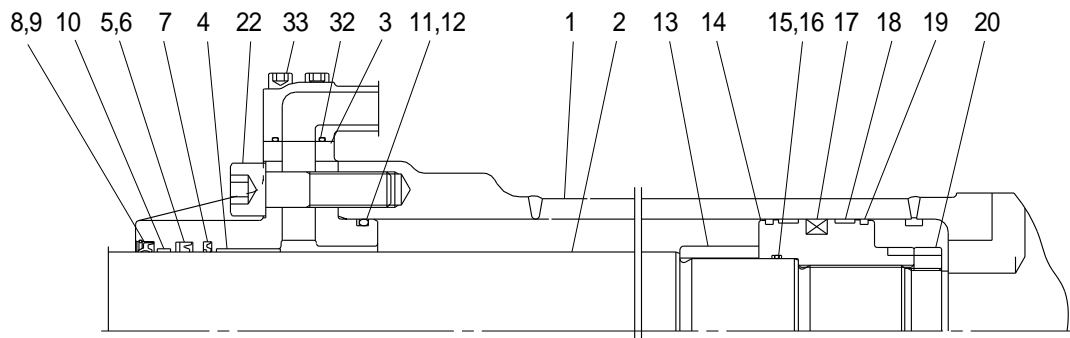

Internal detail

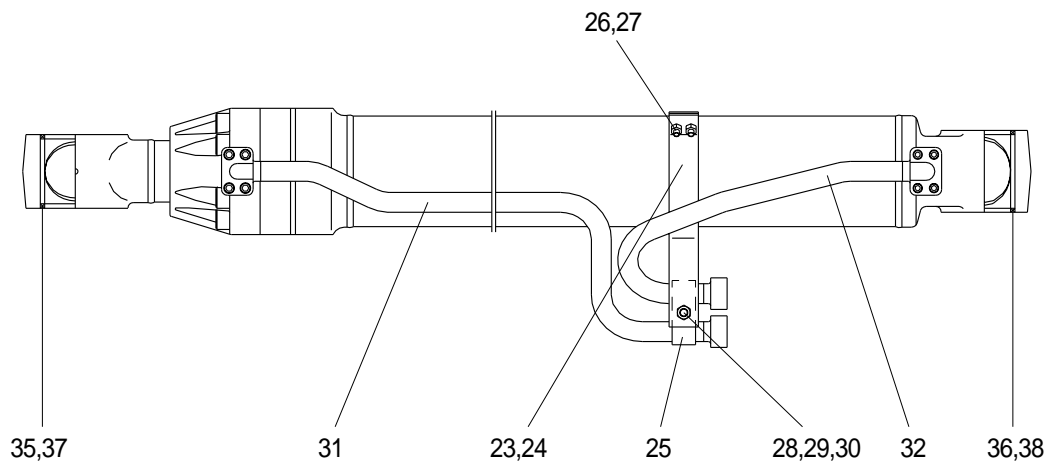

1	Tube assembly	13	Cushion ring	26	Spring washer
2	Rod assembly	14	Piston	27	U-bolt
3	Gland	15	O-ring	28	Hexagon nut
4	Du bushing	16	Back up ring	29	Spring washer
5	Rod seal	17	Piston seal	30	Pipe assembly(B)
6	Back up ring	18	Wear ring	31	Pipe assembly(R)
7	Buffer ring	19	Dust ring	32	O-ring
8	Dust wiper	20	Lock nut	33	Hexagon socket head bolt
9	Snap ring	22	Hexagon socket head bolt	34	Pin bushing(B)
10	Wear ring	23	Band assembly	35	Pin bushing(R)
11	O-ring	24	Band	36	Dust seal
12	Back up ring	25	Hexagon bolt	37	Dust seal

## 2) TOOLS AND TIGHTENING TORQUE

### (1) Tools

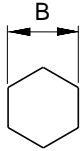
Tool name	Remark	
Allen wrench	8	
	17	
	19	
Spanner	19	
( - ) Driver	Small and large sizes	
Torque wrench	Capable of tightening with the specified torques.	

### (2) Tightening torque

	Part name	Item	Size	Torque	
				kgf · m	lbf · ft
Socket head bolt	Bucket cylinder	22	M22	63±7	455.7±50.6
	Boom cylinder	22	M22	63±7	455.7±50.6
	Arm cylinder	26	M24	78±8	564.2±57.9
Socket head bolt	Bucket cylinder	33	M10	6±1	43.4±7.2
	Boom cylinder	33	M10	6±1	43.4±7.2
	Arm cylinder	39	M10	6±1	43.4±7.2
Hexagon bolt	Bucket cylinder	25	M12	5.5±0.6	39.8±4.3
	Boom cylinder	25	M12	5.5±0.6	39.8±4.3
	Arm cylinder	31	M12	5.5±0.6	39.8±4.3
U-bolt	Bucket cylinder	27	M10	3.2±0.4	23.1±2.9
	Boom cylinder	27	M10	3.2±0.4	23.1±2.9
	Arm cylinder	33	M10	3.2±0.4	23.1±2.9
Lock nut	Bucket cylinder	20	M70	150±15	1085±108.5
	Boom cylinder	20	M70	150±15	1085±108.5
	Arm cylinder	24	M80	150±15	1085±108.5
Piston	Bucket cylinder	14	-	100±10	723.3±72.3
	Boom cylinder	14	-	100±10	723.3±72.3
	Arm cylinder	14	-	100±10	723.3±72.3

### 3) DISASSEMBLY

#### (1) Remove cylinder head and piston rod

- ① Hold the clevis section of the tube in a vise.
- \* Use mouth pieces so as not to damage the machined surface of the cylinder tube. Do not make use of the outside piping as a locking means.

- ② Pull out piston rod(2) about 200mm (7.1in). Because the piston rod is rather heavy, finish extending it with air pressure after the oil draining operation.

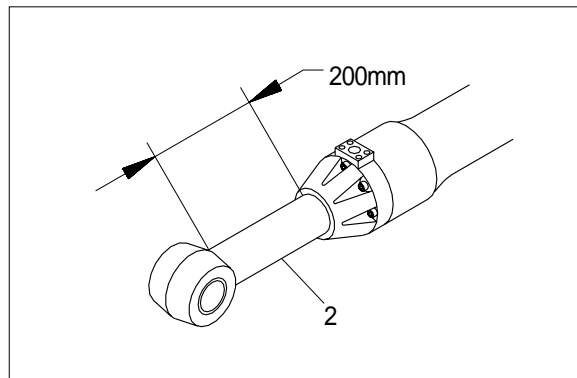

- ③ Loosen and remove socket bolts(22) of the cylinder head in sequence.
- \* Cover the extracted piston rod(2) with rag to prevent it from being accidentally damaged during operation.

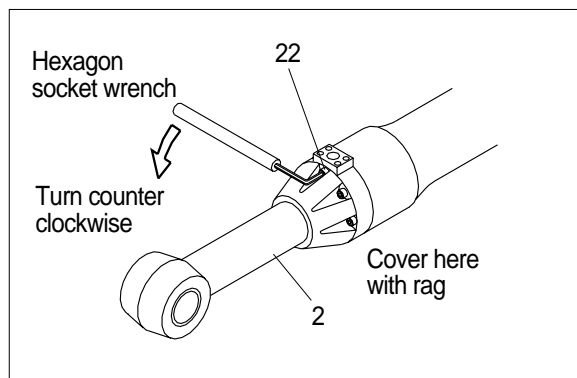

- ④ Draw out cylinder head(3) and piston rod assembly together from cylinder tube(1).
- \* Since the piston rod assembly is heavy in this case, lift the tip of the piston rod(2) with a crane or some means and draw it out. However, when piston rod(2) has been drawn out to approximately two thirds of its length, lift it in its center to draw it completely.

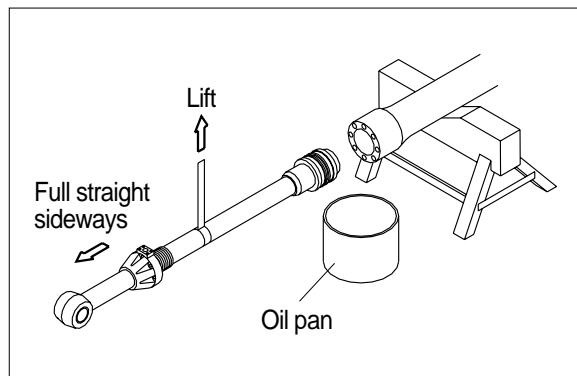

Note that the plated surface of piston rod(2) is to be lifted. For this reason, do not use a wire sling and others that may damage it, but use a strong cloth belt or a rope.

- ⑤ Place the removed piston rod assembly on a wooden V-block that is set level.
- ※ Cover a V-block with soft rag.

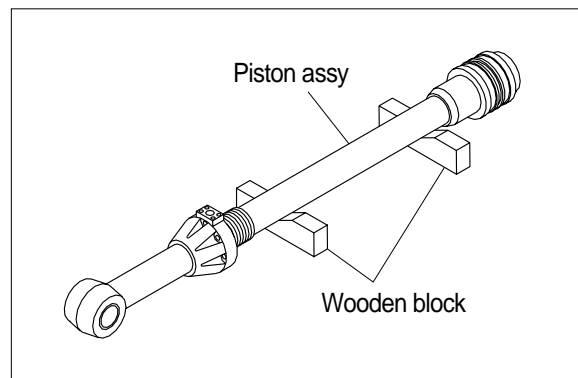

## (2) Remove piston and cylinder head

- ① Remove lock nut(20).
- ※ Since lock nut(20) is tightened to a high torque, use a hydraulic and power wrench that utilizes a hydraulic cylinder, to remove the lock nut(20).
- ② Remove piston assembly(14), back up ring(16), O-ring(15) and cushion ring (13).

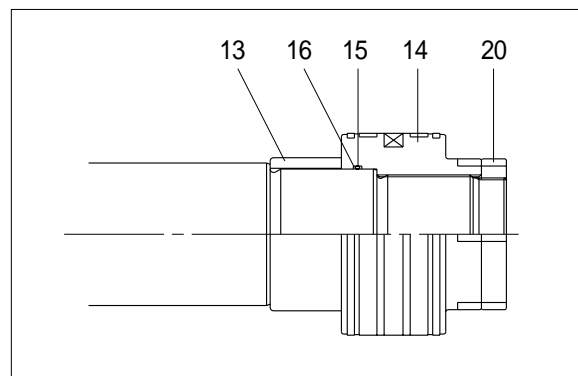

- ③ Remove the cylinder head assembly from piston rod(2).
  - ※ If it is too heavy to move, move it by striking the flanged part of cylinder head (3) with a plastic hammer.
  - ※ Pull it straight with cylinder head assembly lifted with a crane.
- Exercise care so as not to damage the lip of rod bushing(4) and packing (6,7,8,9) by the threads of piston rod(2).

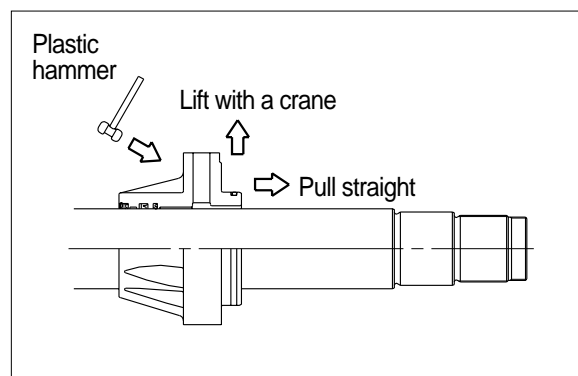

### (3) Disassemble the piston assembly

- ① Remove wear ring(18).
  - ② Remove dust ring(19) and piston seal(17).
- ※ Exercise care in this operation not to damage the grooves.

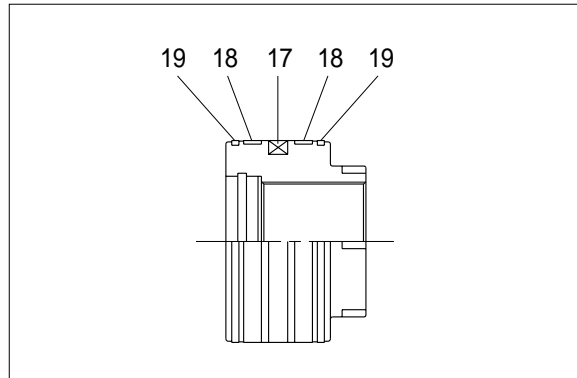

### (4) Disassemble cylinder head assembly

- ① Remove back up ring(12) and O-ring (11).  
Remove snap ring(9), dust wiper(8) and wear ring (10).
- ② Remove back up ring(6), rod seal(5) and buffer ring(7).
- ③ Exercise care in this operation not to damage the grooves.  
Do not remove seal and ring, if does not damaged.

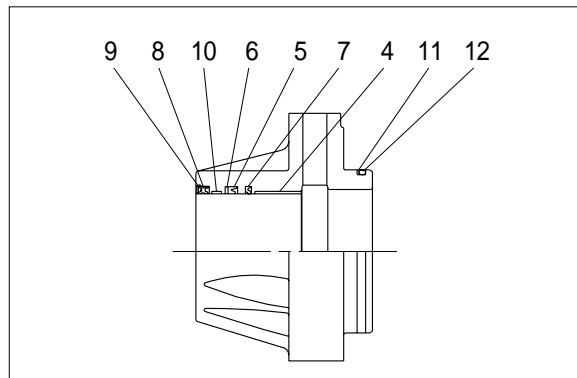

#### 4) ASSEMBLY

##### (1) Assemble cylinder head assembly

※ Check for scratches or rough surfaces if found smooth with an oil stone.

① Coat the inner face of cylinder head(3) with hydraulic oil.

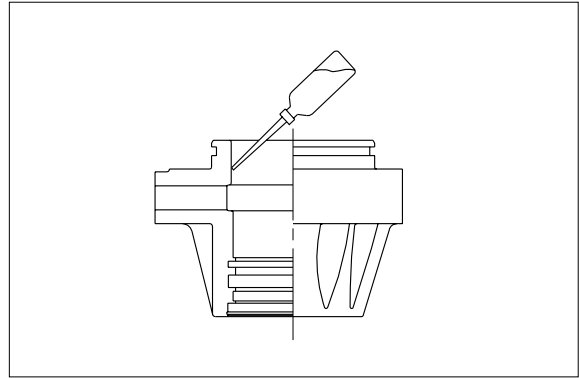

② Coat dust wiper(8) with grease and fit dust wiper(8) to the bottom of the hole of dust seal.

At this time, press a pad metal to the metal ring of dust seal.

③ Fit snap ring(9) to the stop face.

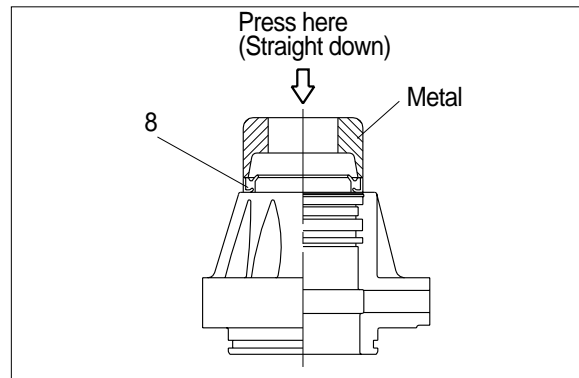

④ Fit wear ring(10), back up ring(6), rod seal(5) and buffer ring(7) to corresponding grooves, in that order.

※ Coat each packing with hydraulic oil before fitting it.

※ Insert the backup ring until one side of it is inserted into groove.

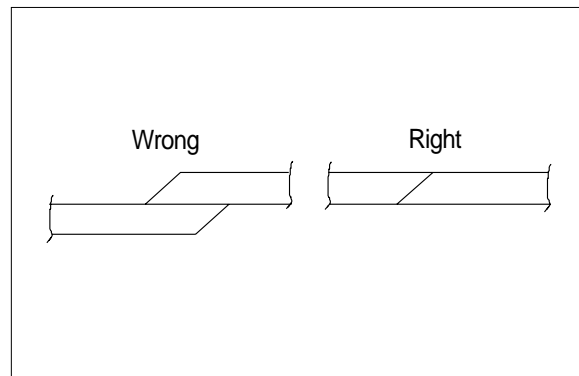

※ Rod seal(5) has its own fitting direction. Therefore, confirm it before fitting them.

※ Fitting rod seal(5) up side down may damage its lip. Therefore check the correct direction that is shown in fig.

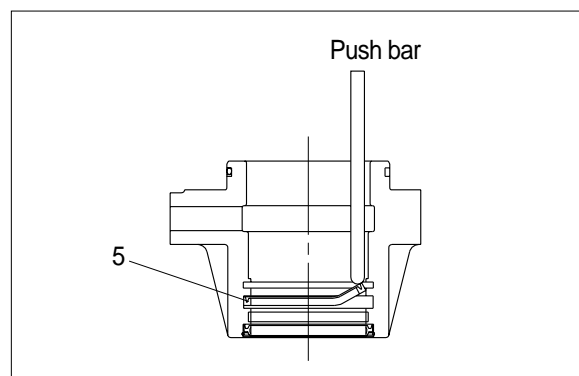

- ⑤ Fit back up ring(12) to cylinder head (3).
- ※ Put the backup ring in the warm water of 30~50°C
- ⑥ Fit O-ring(11) to cylinder head(3).

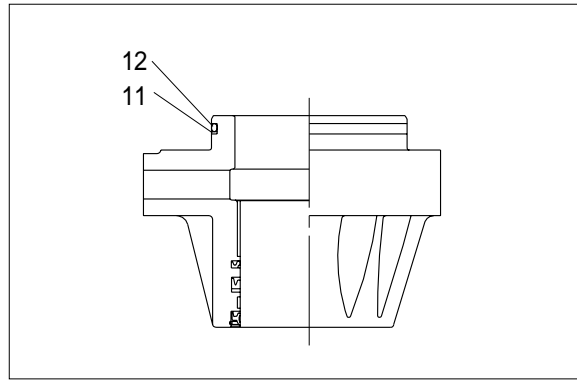

**(2) Assemble piston assembly**

- ※ Check for scratches or rough surfaces. If found smooth with an oil stone.
- ① Coat the outer face of piston(14) with hydraulic oil.

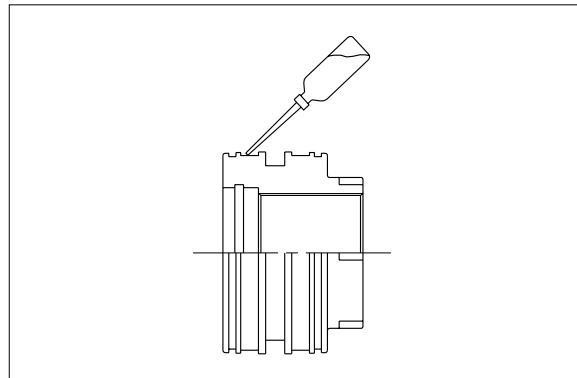

- ② Fit piston seal(17) to piston
- ※ Put the piston seal in the warm water of 60~100°C for more than 5 minutes.
- ※ After assembling the piston seal, press its outer diameter to fit in.

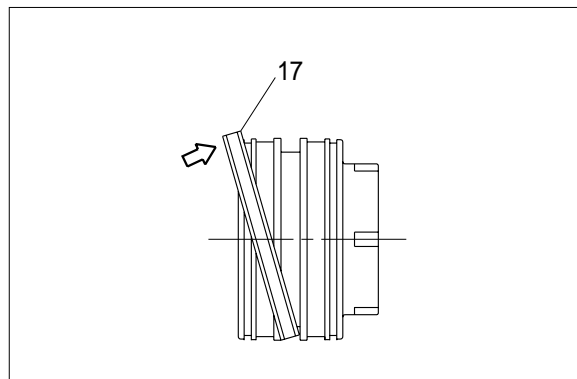

- ③ Fit wear ring(18) and dust ring(19) to piston(14).
- ④ Fit back up ring(16) and O-ring(15) to piston(14).

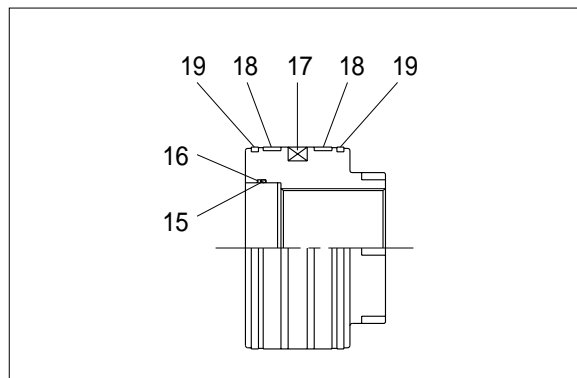

**(3) Install piston and cylinder head**

- ① Fix the piston rod assembly to the work bench.
- ② Apply hydraulic oil to the outer surface of piston rod(2), the inner surface of piston and cylinder head.
- ③ Insert cylinder head assembly to piston rod.

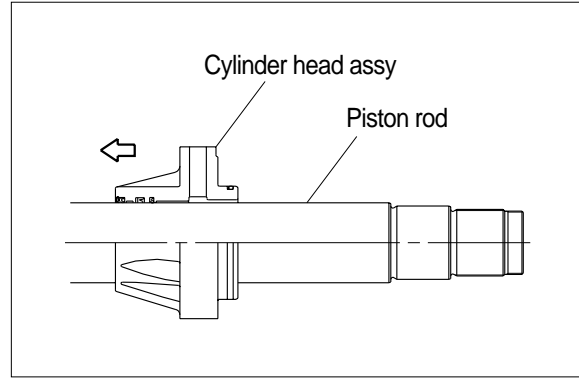

- ④ Insert cushion ring(13) to piston rod.
- ※ Note that cushion ring(13) has a direction in which it should be fitted.

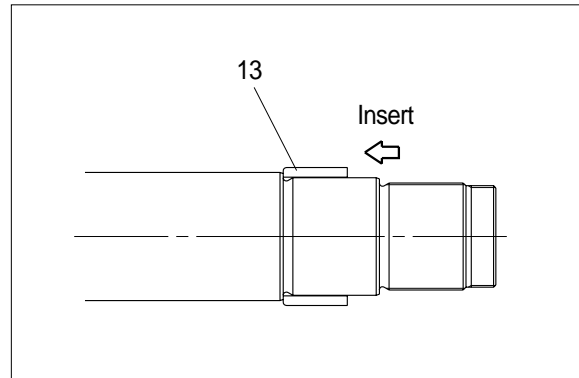

- ⑤ Fit piston assembly to piston rod.
- Tightening torque :  
 $100 \pm 10 \text{ kgf} \cdot \text{m} (723.3 \pm 72.3 \text{ lbf} \cdot \text{ft})$

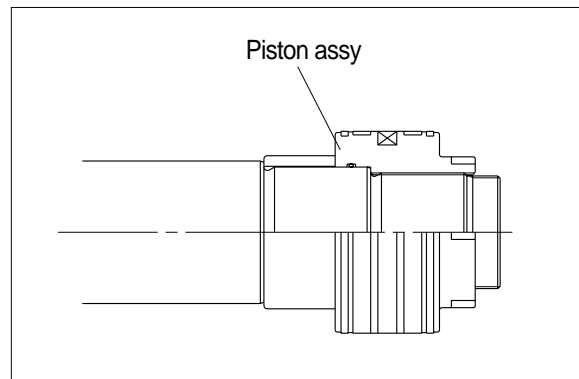

- ⑥ Fit lock nut(20) to piston rod.
- Tightening torque :

Item	kgf · m	lbf · ft
bucket	$150 \pm 15$	$1085 \pm 108.5$
boom	$150 \pm 15$	$1085 \pm 108.5$
arm	$150 \pm 15$	$1085 \pm 108.5$

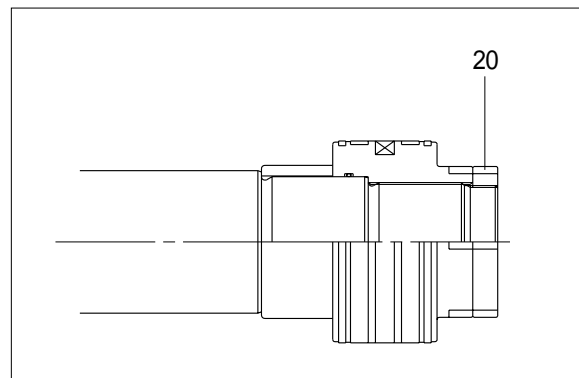



#### (4) Overall assemble

- ① Place a V-block on a rigid work bench.  
Mount the cylinder tube assembly(1) on it and fix the assembly by passing a bar through the clevis pin hole to lock the assembly.
- ② Insert the piston rod assembly in to the cylinder tube assembly, while lifting and moving the piston rod assembly with a crane.
  - ※ Be careful not to damage piston seal by thread of cylinder tube.
- ③ Match the bolts holes in the cylinder head flange to the tapped holes in the cylinder tube assembly and tighten socket bolts to a specified torque.
  - ※ Refer to the table of tightening torque.

