

GROUP 8 TURNING JOINT

1. REMOVAL AND INSTALL

1) REMOVAL

- (1) Lower the work equipment to the ground and stop the engine.
- (2) Operate the control levers and pedals several times to release the remaining pressure in the hydraulic piping.
- (3) Loosen the breather slowly to release the pressure inside the hydraulic tank.

▲ Escaping fluid under pressure can penetrate the skin causing serious injury.

※ When pipes and hoses are disconnected, the oil inside the piping will flow out, so catch it in oil pan.

- (4) Disconnect all hoses .
- (5) Sling the turning joint assembly (1) and remove the mounting bolt(2).
 - Weight : 54kg(119lb)
 - Tightening torque : $12 \pm 1.3\text{kgf} \cdot \text{m}$
($88 \pm 9.4\text{lb} \cdot \text{ft}$)
- (6) Remove the turning joint assembly.
 - ※ When removing the turning joint, check that all the hoses have been disconnected.

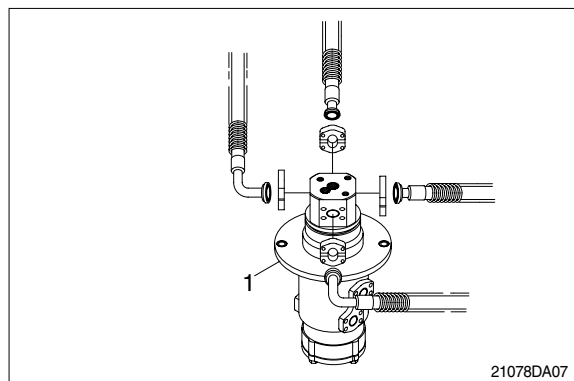

2) INSTALL

- (1) Carry out installation in the reverse order to removal.
 - ※ Take care of turning joint direction.
 - ※ Assemble hoses to their original positions.
 - ※ Confirm the hydraulic oil level and check the hydraulic oil leak or not.

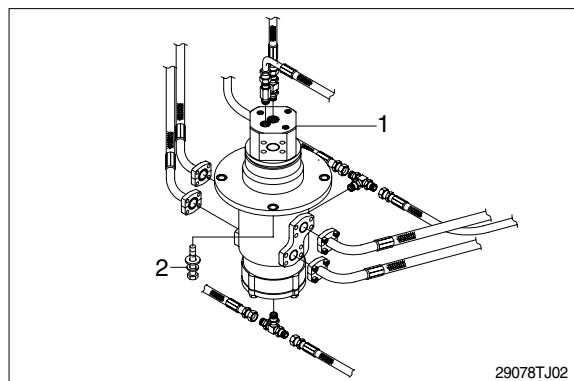

2. DISASSEMBLY AND ASSEMBLY

1) STRUCTURE

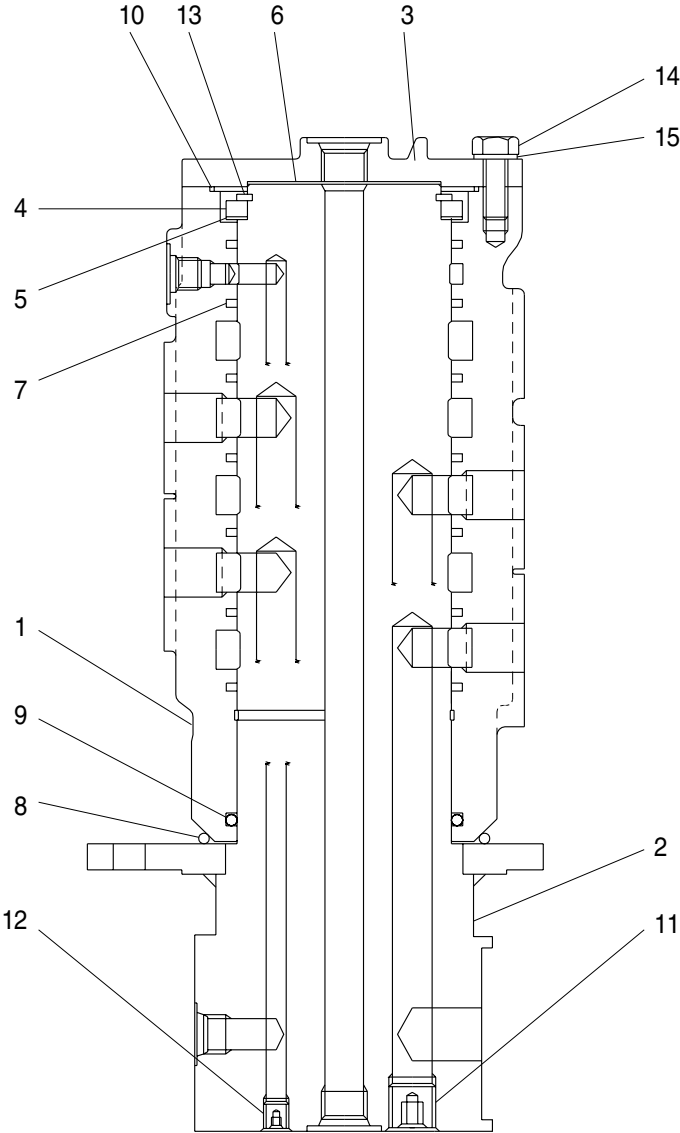

(R290-7 TIER II) R210TJT2

- | | | | | | |
|---|----------------|----|--------------|----|---------------|
| 1 | Hub | 6 | Shim | 11 | Wear ring |
| 2 | Shaft assembly | 7 | Slipper seal | 12 | Retainer ring |
| 3 | Cover | 8 | O-ring | 13 | Plug |
| 4 | Spacer | 9 | O-ring | 14 | Hexagon bolt |
| 5 | Shim | 10 | O-ring | 15 | Spring washer |

2) DISASSEMBLY

※ Before the disassembly, clean the turning joint.

- (1) Remove bolts(14), washer(15) and cover(3).

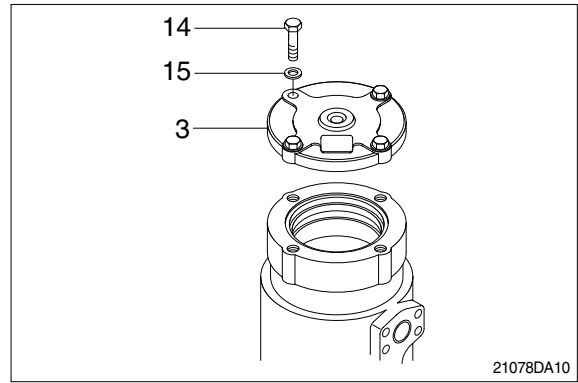

- (2) Remove shim(6) and O-ring(10).

- (3) Remove retainer ring(12), spacer(4) and shim(5).

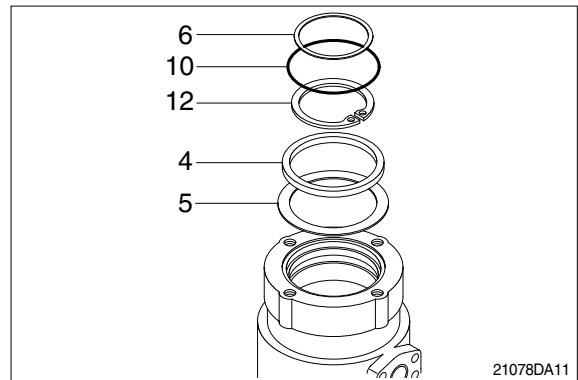

- (4) Place body(1) on a V-block and by using a wood buffer at the shaft end, hit out shaft(2) to about 1/2 from the body with a hammer.

※ Take care not to damage the shaft(2) when remove body(1) or rest it sideways.
※ Put a fitting mark on body(1) and shaft(2).

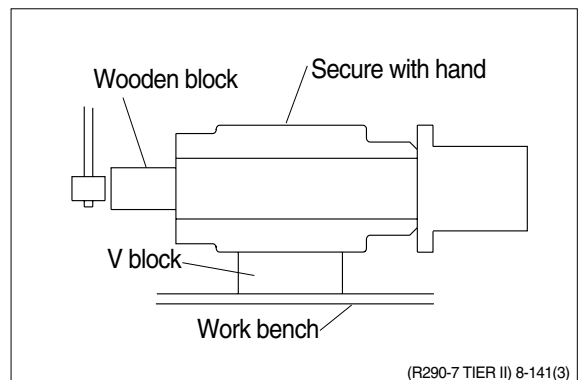

- (5) Remove six slipper seals(7) and O-ring(9), two ring wear(11) from body(1).

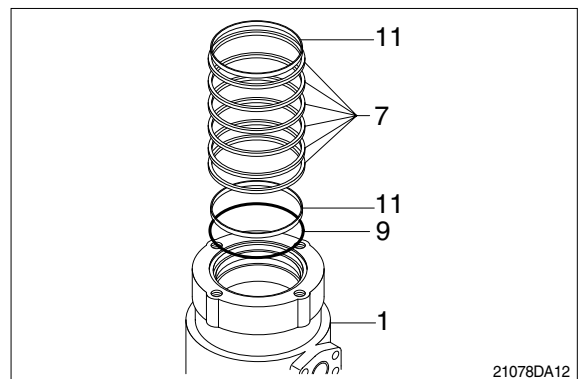

3) ASSEMBLY

- ※ Clean all parts.
- ※ As a general rule, replace oil seals and O-ring.
- ※ Coat the sliding surfaces of all parts with engine oil or grease before installing.

(1) Fix seven slipper seal(7) and O-ring(9), two ring wear(11) to body(1).

(2) Fit O-ring(8) to shaft(2).

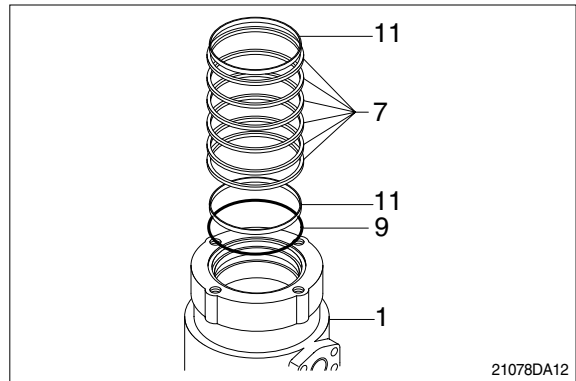

(3) Set shaft(2) on block, tap body(1) with a plastic hammer to install.

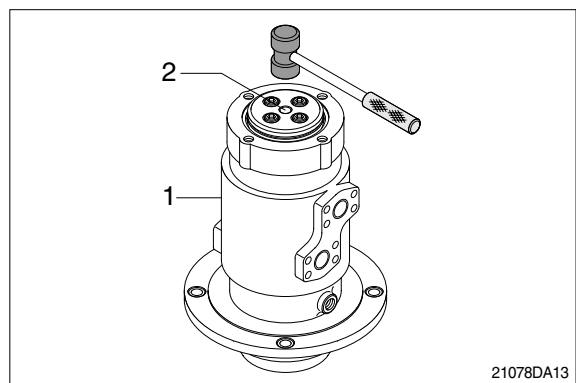

(4) Fit shim(5), spacer(4) and retainer ring (12) to shaft(2).

(5) Fit O-ring(10) to body(1).

(6) Fit shim(6) to shaft(2).

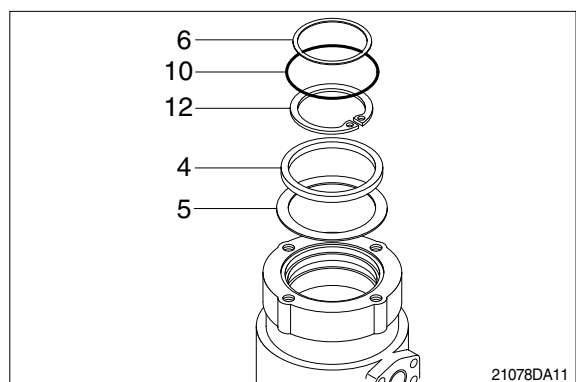

- (7) Install cover(3) to body(1) and tighten bolts(14).
· Torque : 10~12.5kgf · m(72.3~90.4lbf · ft)

