

GROUP 5 SWING DEVICE

1. REMOVAL AND INSTALL OF MOTOR

1) REMOVAL

- (1) Lower the work equipment to the ground and stop the engine.
- (2) Loosen the breather slowly to release the pressure inside the hydraulic tank.

▲ Escaping fluid under pressure can penetrate the skin causing serious injury.

※ When pipes and hoses are disconnected, the oil inside the piping will flow out, so catch it in oil pan.

- (3) Disconnect pipe assy(2, 3).
- (4) Disconnect pilot line hoses(4, 5, 6, 7, 8).
- (5) Sling the swing motor assembly(1) and remove the swing motor mounting bolts(9).
 - Motor device weight : 190kg(420lb)
 - Tightening torque : 58.4kgf · m
(422.4lbf · ft)

- (6) Remove the swing motor assembly.

※ When removing the swing motor assembly, check that all the piping have been disconnected.

2) INSTALL

- (1) Carry out installation in the reverse order to removal.
- (2) Bleed the air from the swing motor.
 - ① Remove the air vent plug.
 - ② Pour in hydraulic oil until it over flows from the port.
 - ③ Tighten plug lightly.
 - ④ Start the engine, run at low idling, and check oil come out from plug.
 - ⑤ Tighten plug fully.
- (3) Confirmed the hydraulic oil level and check the hydraulic oil leak or not.

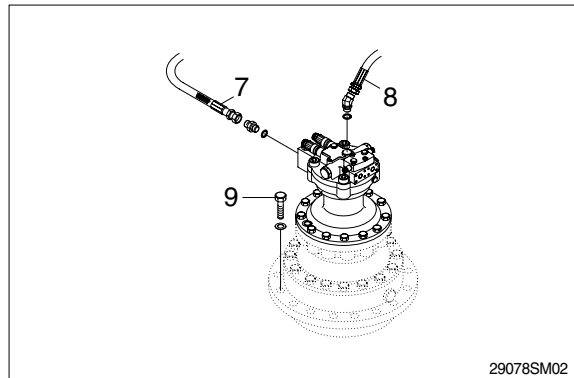
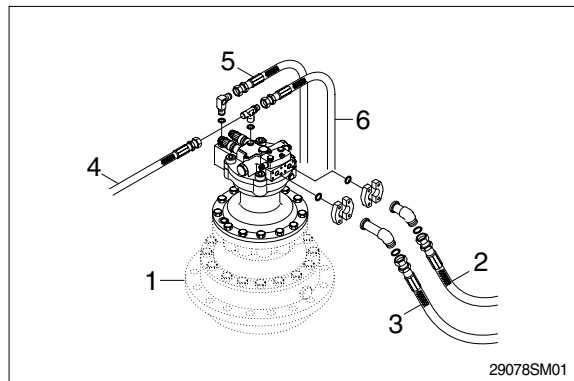

2. SWING MOTOR

1) STRUCTURE

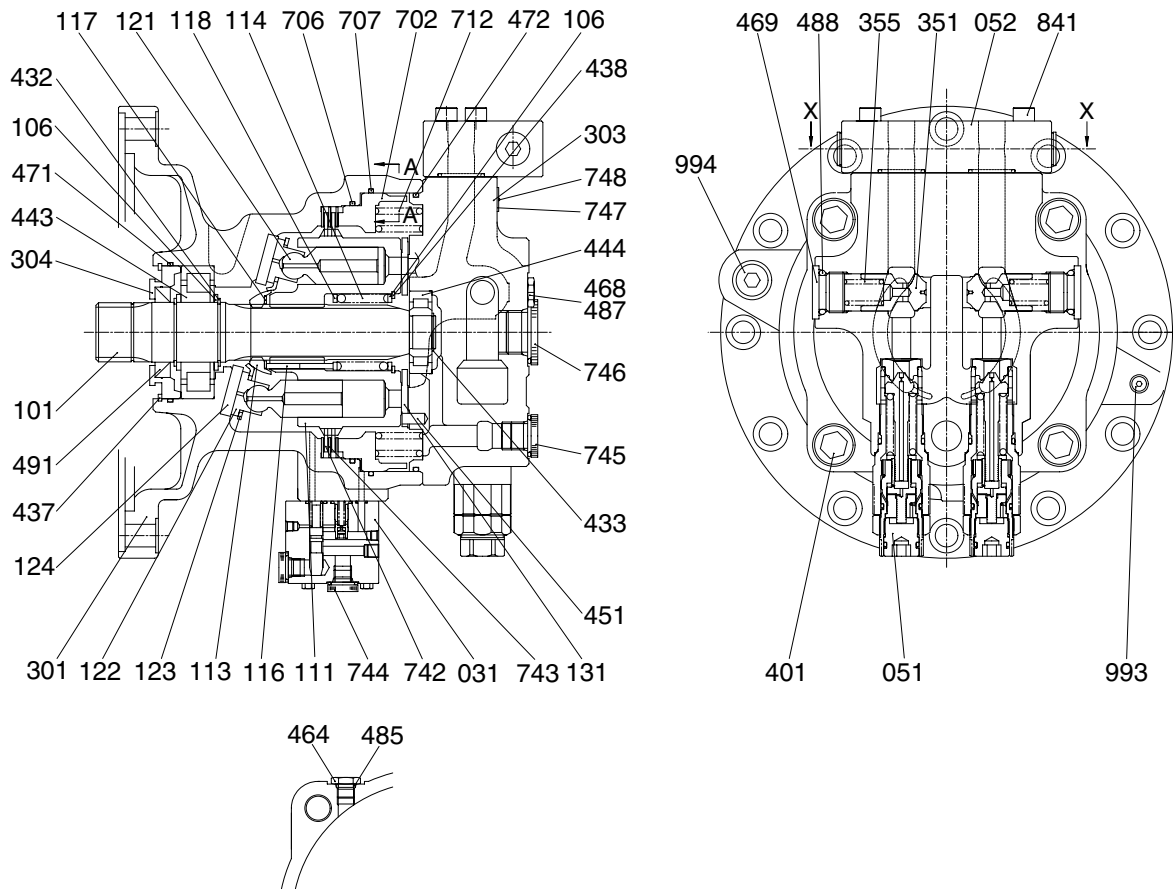

30572SM02

031	Brake valve	303	Casing	485	O-ring
051	Relief valve	304	Front cover	487	O-ring
052	Valve assy	351	Plunger	488	O-ring
101	Drive shaft	355	Spring	491	Oil seal
106	Spacer	401	Socket bolt	702	Piston
111	Cylinder block	432	Snap ring	706	O-ring
113	Bushing	433	Snap ring	707	O-ring
114	Spring	437	Snap ring	712	Brake spring
116	Push rod	438	Snap ring	742	Lining plate
117	Spacer	443	Roller bearing	743	Separate plate
118	Spacer	444	Needle bearing	744	Plug
121	Piston	451	Pin	745	Plug
122	Shoe	464	Plug	746	Plug
123	Retainer	468	Plug	841	Socket bolt
124	Shoe plate	469	Plug	993	Plug
131	Valve plate	471	O-ring	994	Plug
301	Casing	472	O-ring		

2) DISASSEMBLY

- (1) Lift the motor out. Clean the motor in kerosene and dry with compressed air.
 - ※ To avoid dust inside the motor, mask all the ports of the motor with tapes.

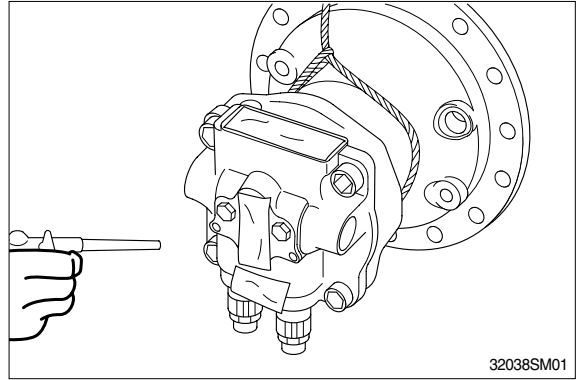

- (2) Loosen the drain plug to discharge oil in the casing(301).

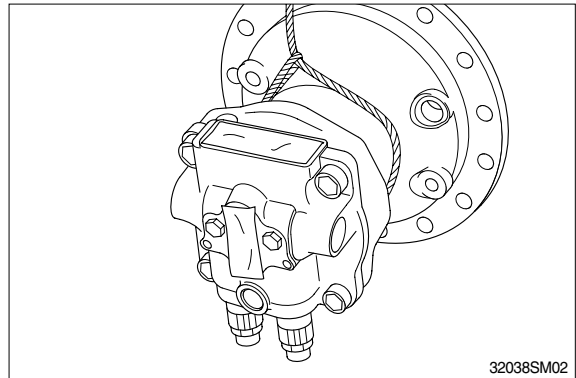

- (3) Fix the drive shaft(101) on the workbench with the end of output shaft down. Put matching marks on casing (301) and valve casing(303) for easy reassembly.

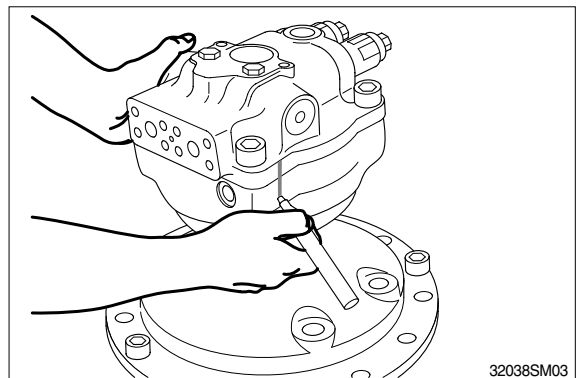

- (4) Remove the valve(052).

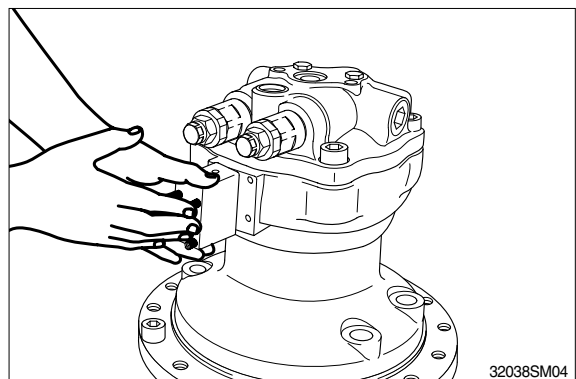

- (5) Remove the relief valve(051) from valve casing(303).

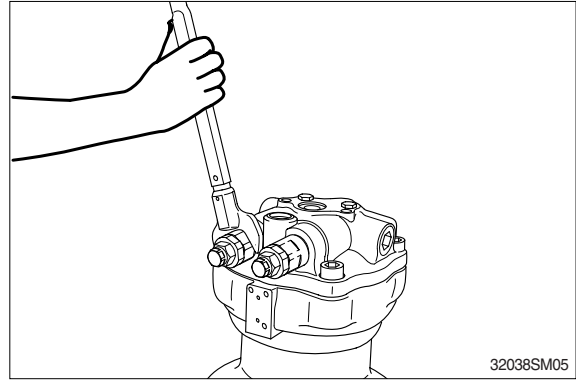

- (6) Remove plug(469) from valve casing (303) and spring(355), plunger(351).
※ Be careful not to damage the plunger seat assembly.

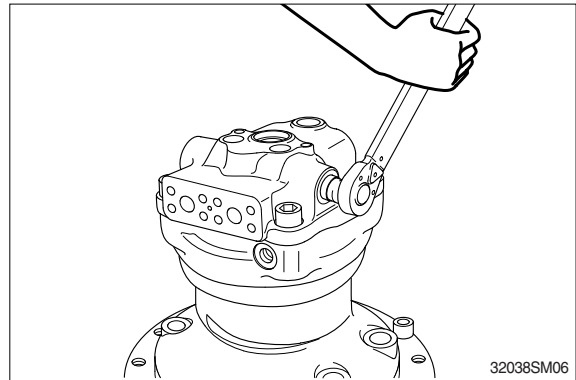

- (7) Remove valve casing(303) from casing (301). Then, remove the valve plate(131) from valve casing(303) with care.

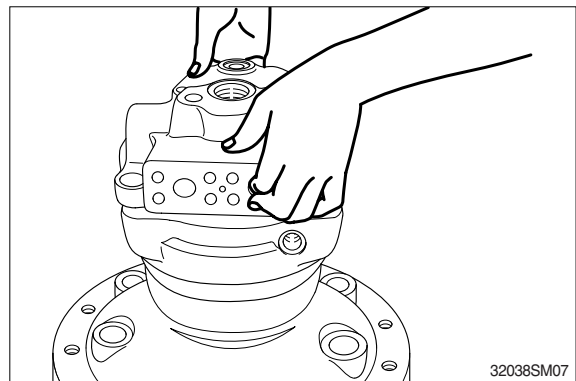

- (8) Remove the brake spring(712) from brake piston(702).

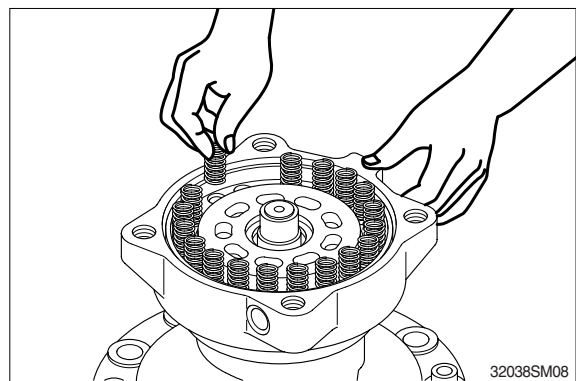

- (9) Remove brake piston(702) from casing (301).

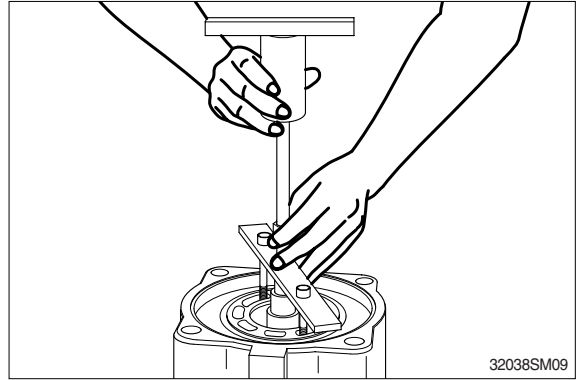

- (10) Remove the cylinder(111) from the output shaft (101) with the motor positioned horizontally. Remove piston(121), pushing Retainer(123), Bushing(113), spacer (117) and shoe plate(124).

※ If shoe plate would not removed easily, try again after procedure(14).

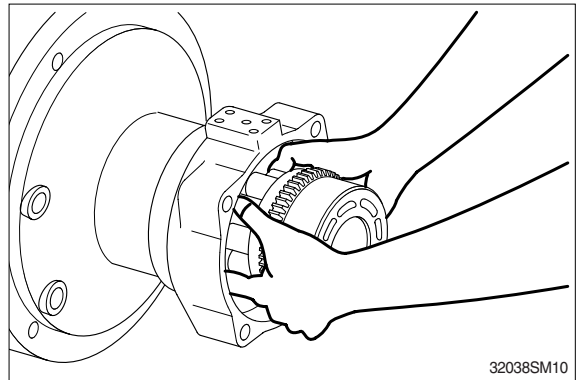

- (11) Remove friction plate(742) and separate plate(743) from casing(301).

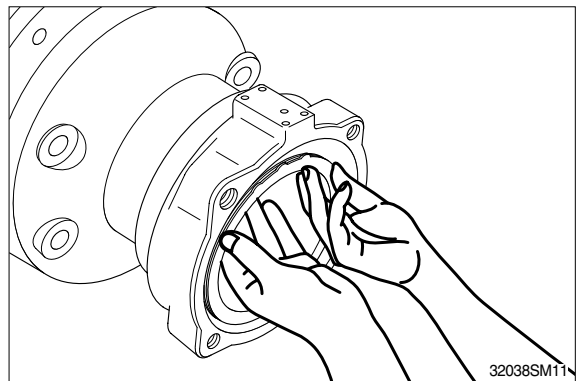

- (12) Remove snap ring(437) with plier and remove the front cover(304) from casing(301).

※ Front cover could be removed with sliding shaft if necessary.

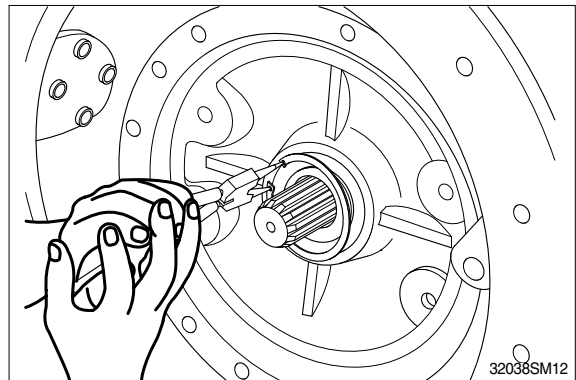

(13) Remove drive shaft(101) from casing (301).

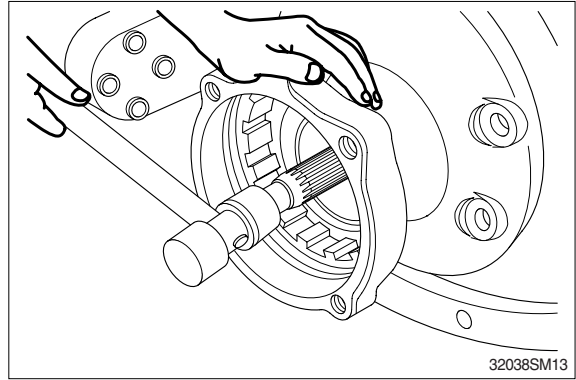

(14) Remove the shoe plate(124) from casing (301).

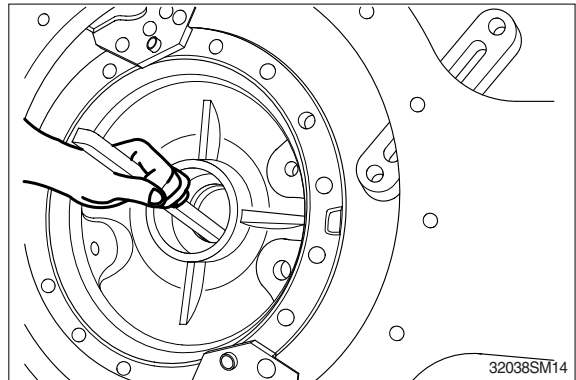

(15) Proceed with following job only when necessary.

- ① Remove the snap ring(432), spacer(106) from drive shaft(101) and remove the cone of roller bearing(443) by press.

※ Do not reuse bearings.

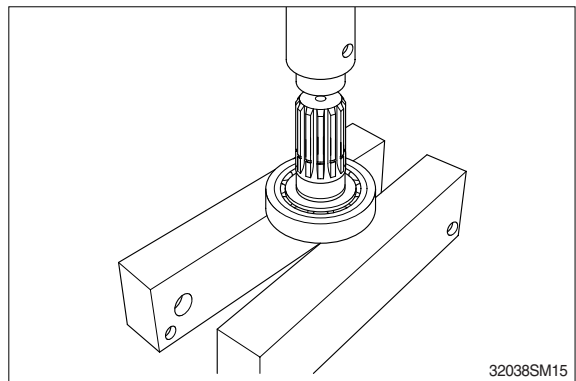
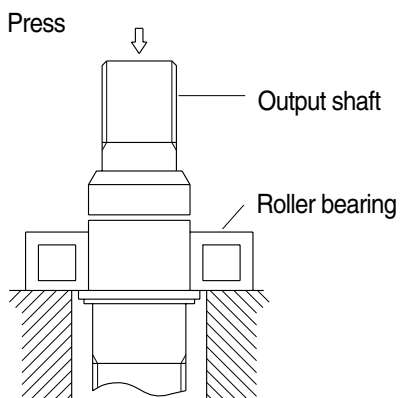

- ② Remove oil seal(491) from front cover (304).

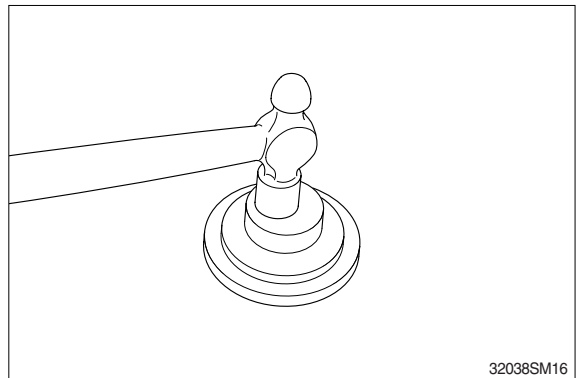

- ③ Remove the roller bearing(444) from the valve casing(303) by using slide hammer bearing puller.

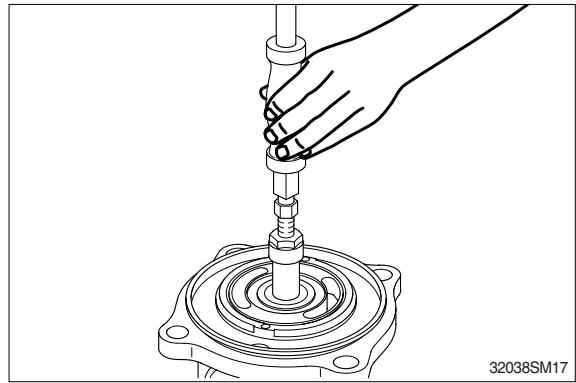

- ④ When disassembling the relief valve, release the plug(3).
Remove the piston(7), spring seat(9), spring(8) and plunger(6) with the body(1) downwards.

※ Do not release the lock nut(15).

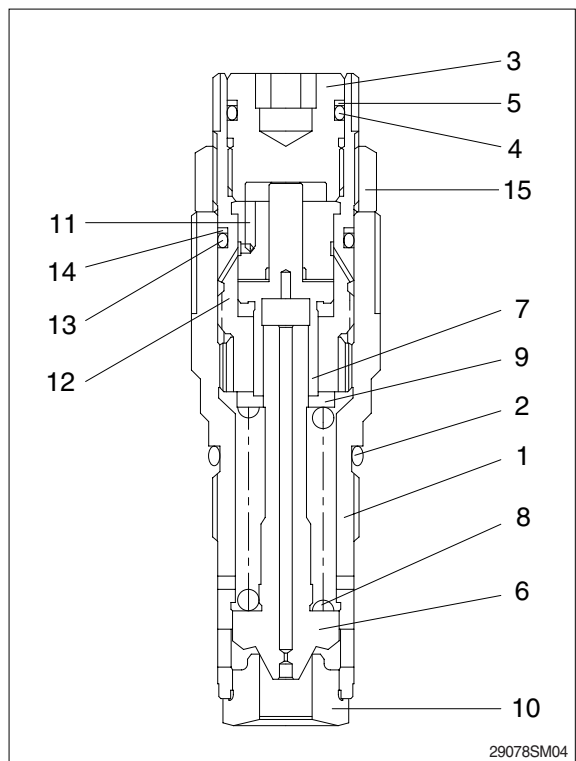

This completes disassembly.

3) ASSEMBLY

Do the reassembly in the reverse procedure of the disassembly.

- (1) Place the casing(301) on the workbench with the valve casing(303) downward.

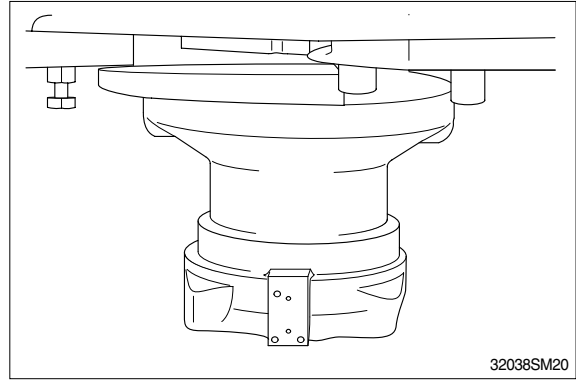

- (2) When reassembling the roller bearing, install the snap ring(432), and spacer(106) to the drive shaft(101). Insert the collar and cone of the roller bearing(443). Install the spacer(106) and stop ring(432). Install stop ring(433) to the output shaft (101) by heating the cone of the roller bearing(444).

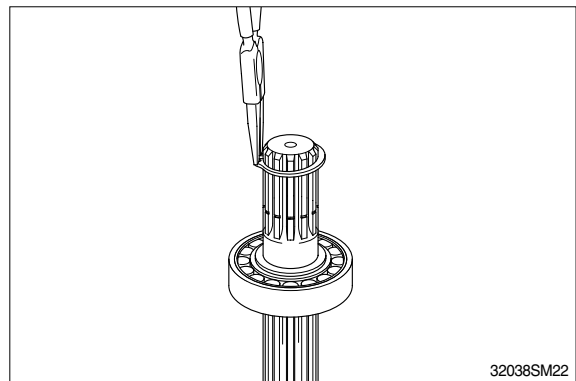
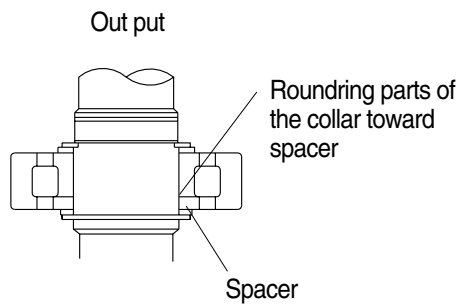
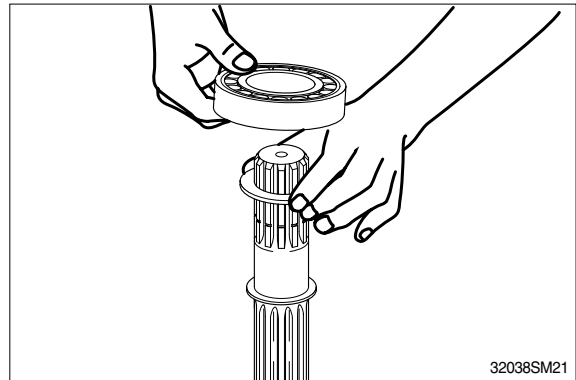

- (3) Insert the drive shaft(101) into the casing (301) with the end of output shaft upward and tap the outer race of roller bearing with the hammer.

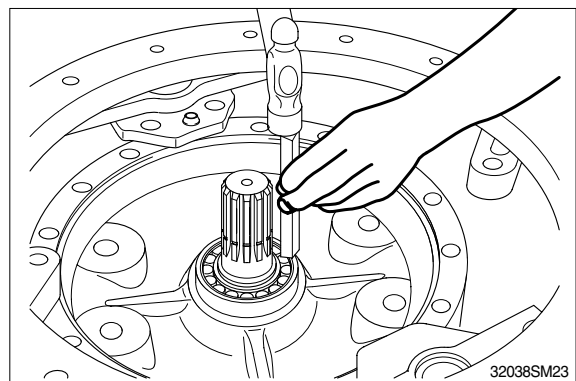

(4) Tack O-ring(471) to the casing(301).

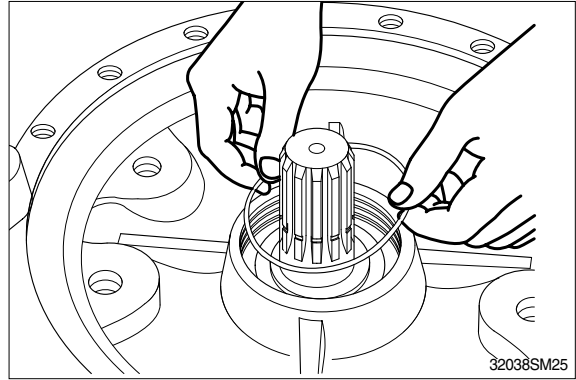

(5) Reassemble the front cover(304) to the casing(301).

※ Apply grease to the rib of oil seal to avoid damage to the rib.

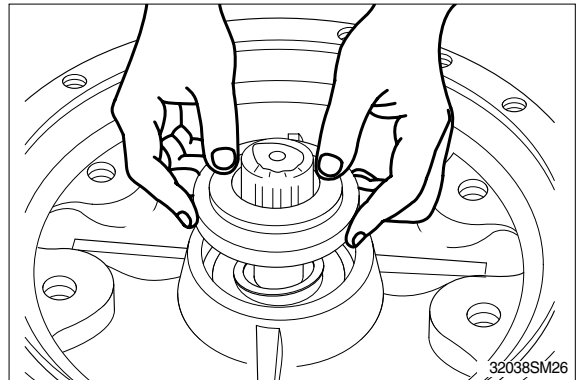

(6) Install the snap ring(437) to the casing (301).

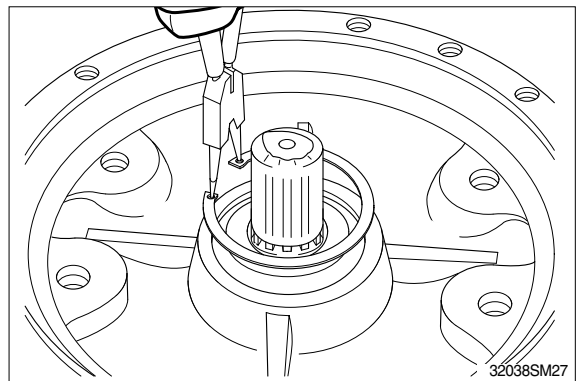

(7) Insert the shoe plate(124) with the casing (301) position horizontally.

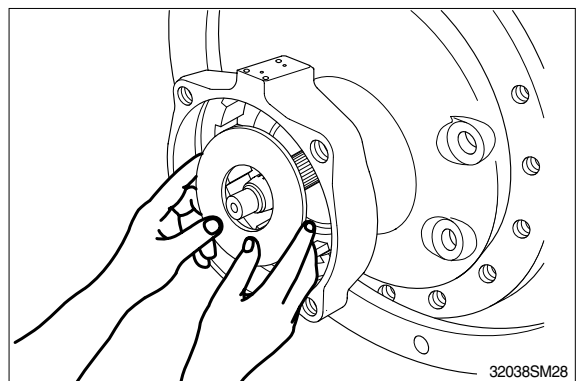

(8) Insert the push rod(116) into the cylinder (111). Place the busing(113) assembled with spacer(117) onto the cylinder.

※ Insert two push rods in each hole.

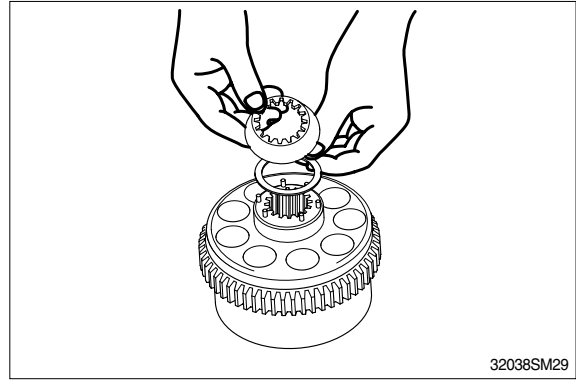

(9) Install the piston sub-assembly(121, 122) to the retainer(123).



(10) Reassemble the piston assembly(121, 122) to the cylinder(111).

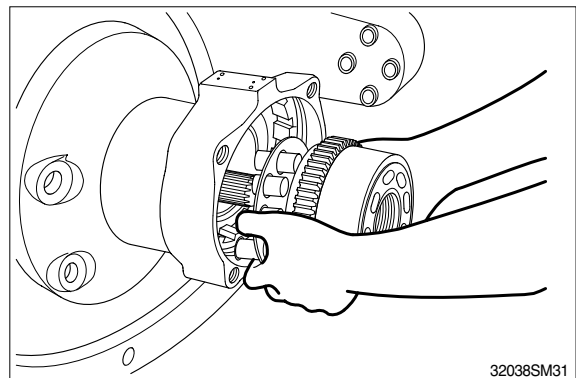

(11) Place the casing(301) under the front cover(304) and reassemble 3 sheets of separate plate(743) and then 2 sheets of friction plate(742) to the casing(301).

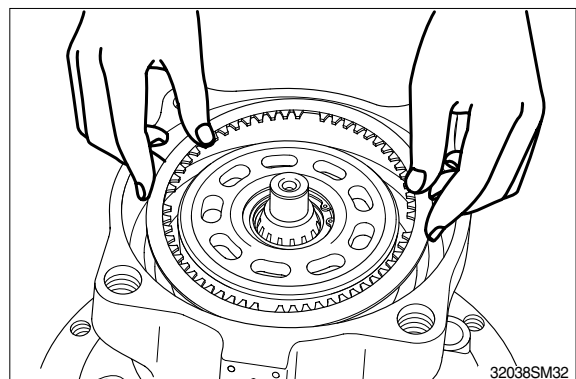

(12) Insert O-ring(706, 707) inside the casing (301).

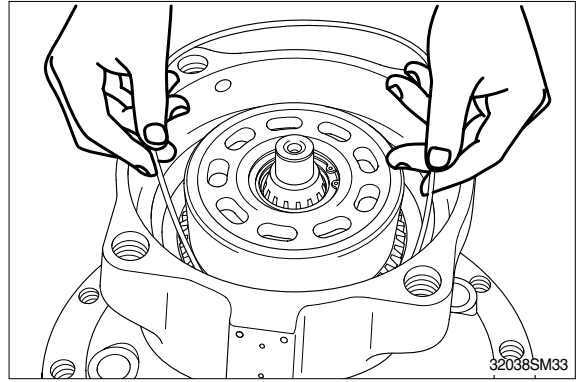

(13) Reassemble brake piston(702) to the casing(301).

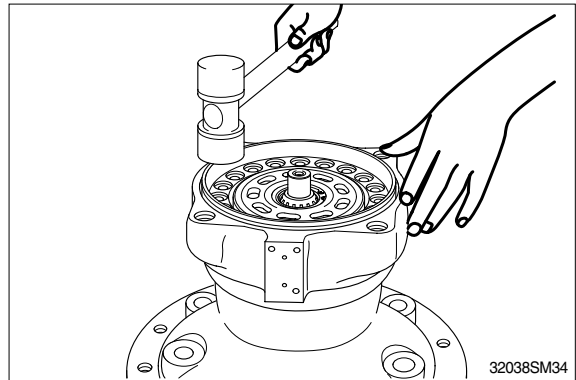

(14) Reassemble brake spring(712) to the brake piston(702).

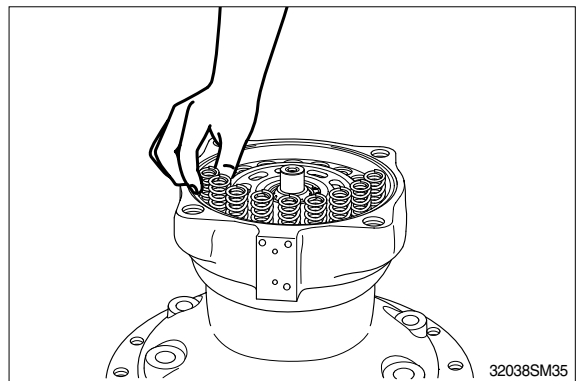

(15) When assembling the roller bearing(444), insert the roller bearing(444) into valve casing(303) by hammering.

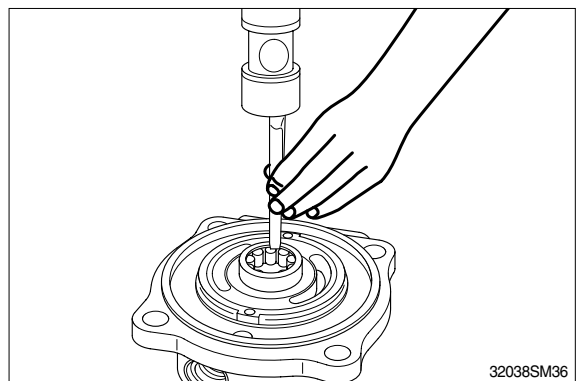

(16) Reassemble valve plate(131) to the valve casing(303) and reassemble O-ring(472).

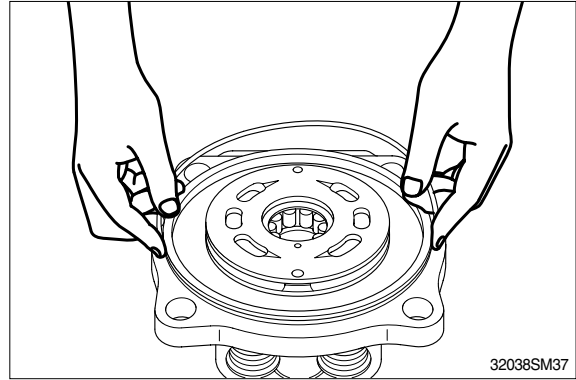

(17) Connect the valve casing(303) with the casing(301) and tighten the hexagon screw(401).

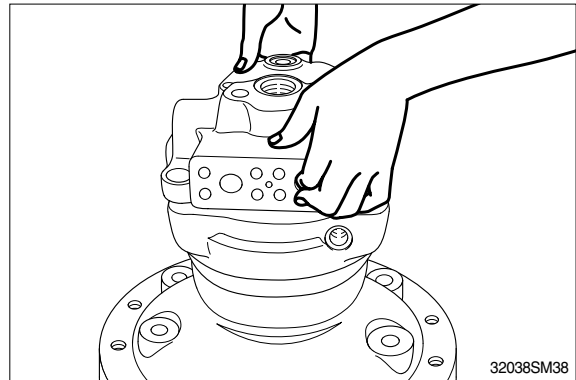

(18) Insert plunger(351) and spring(355) in the valve casing and install O-ring(488). Tighten plug(469) to the valve casing.

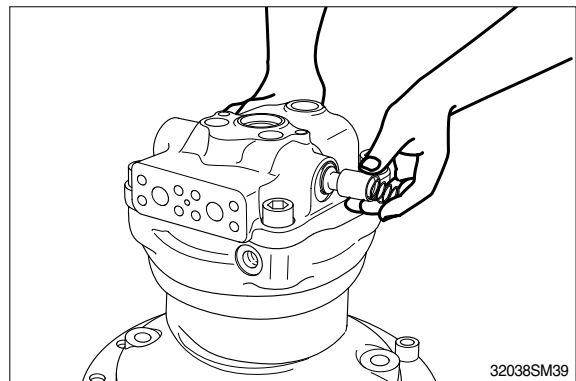

(19) Insert O-rings(051-1) to the relief valve (051) and reassemble them to valve casing(303).

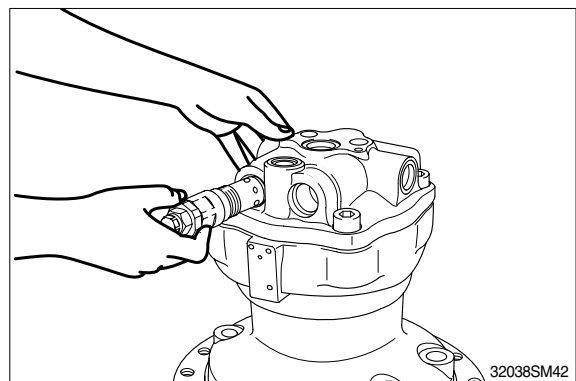

(20) Tighten the plug(468) to valve casing(303) with O-ring(487) and tighten the plug(464) to casing(301) with O-ring(485).

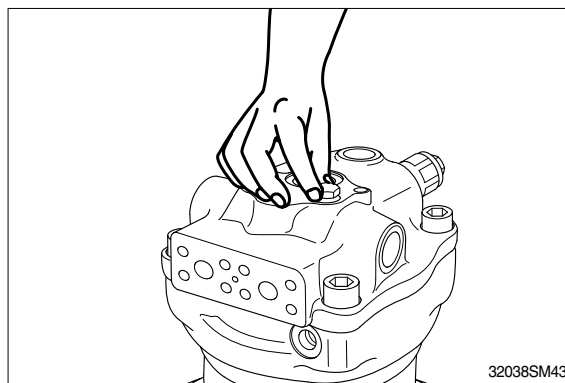

(21) Connect the valve casing(303) with the casing(301).

This completes assembly.

3. REMOVAL AND INSTALL OF REDUCTION GEAR

1) REMOVAL

- (1) Remove the swing motor assembly.
For details, see **removal of swing motor assembly**.
- (2) Sling reduction gear assembly(1) and remove mounting bolts(2).
- (3) Remove the reduction gear assembly.
 - Reduction gear device weight : 260kg
(573lb)



2) INSTALL

- (1) Carry out installation in the reverse order to removal.
 - Mounting bolt : 49.2~66.6kgf · m
(356~481lbf · ft)

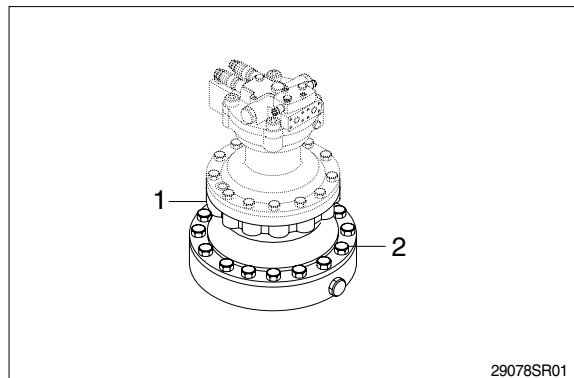

4. REDUCTION GEAR

1) STRUCTURE

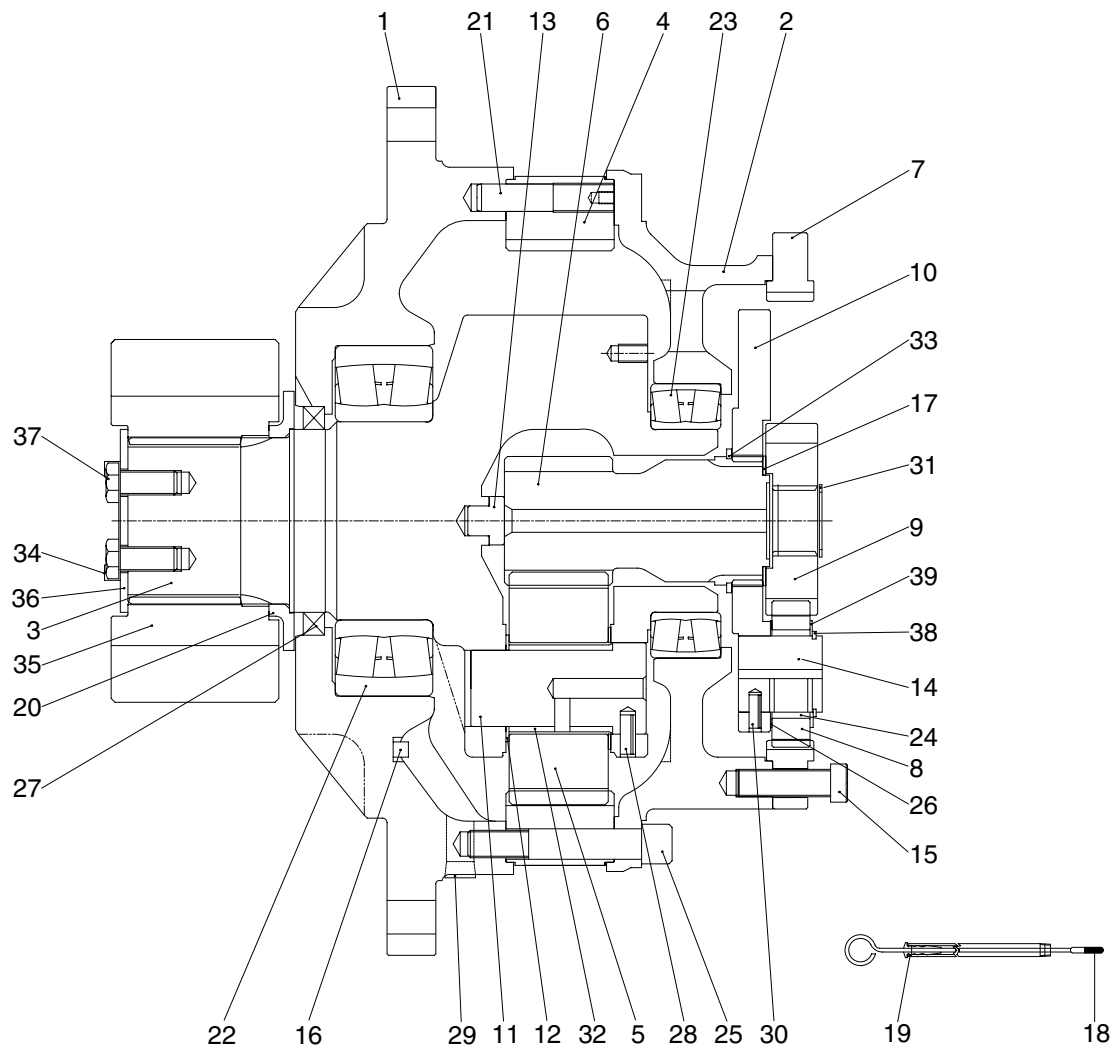

30572SR01

1	Front casing	14	Pin 1	27	Oil seal
2	Middle casing	15	Side plate 1	28	Spring pin
3	Drive shaft	16	Magnet	29	Pressure plug
4	Ring gear 2	17	Side plate 3	30	Spring pin
5	Planet gear 2	18	Gauge bar	31	Stop ring
6	Sun gear 2	19	Gauge pipe	32	Bushing 2
7	Ring gear 1	20	Spacer ring	33	Stop ring
8	Planet gear 1	21	Knock pin	34	Lock washer
9	Sun gear 1	22	Roller bearing	35	Pinion gear
10	Carrier	23	Roller bearing	36	Lock plate
11	Pin 2	24	Needle gauge	37	Hexagon bolt
12	Thrust washer	25	Socket bolt	38	Stop ring
13	Thrust button	26	Socket bolt	39	Side plate 2

2) DISASSEMBLY

- (1) Spread off the 4 corners of lock washer (34) with a tool.
 - ※ Do not reuse lock washer(34).Loosen the hexagon bolts(37) and then remove lock washer(34) and lock plate(36) from the pinion gear(35). Remove pinion gear(35) and spacer ring (20) from the drive shaft(3).

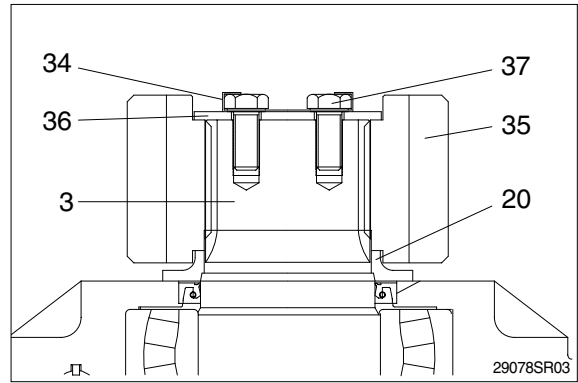

- (2) Remove gauge bar(18) and gauge pipe (19) from the swing motor casing. Pour the gear oil out of reduction gear into the clean bowl to check out the friction decrease.

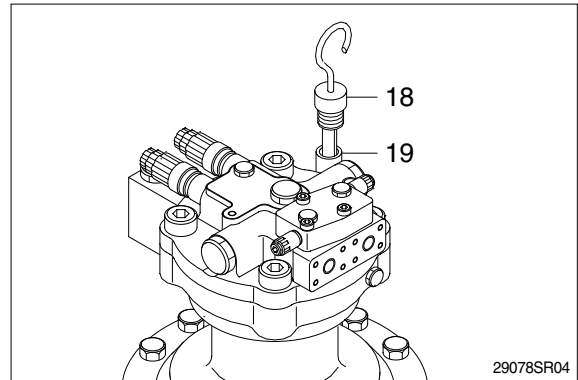

- (3) Loosen the socket bolt(26) to separate swing motor from reduction gear.

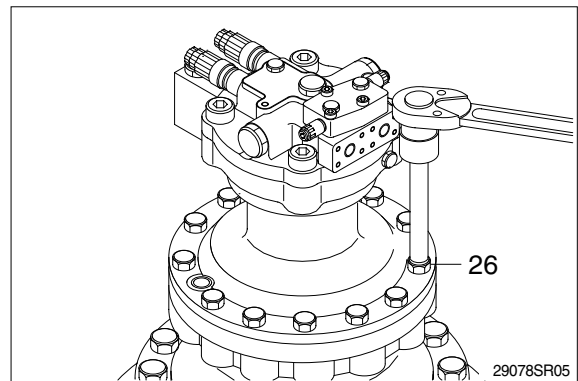

- (4) Remove stop ring(31) and then sun gear 1(9).

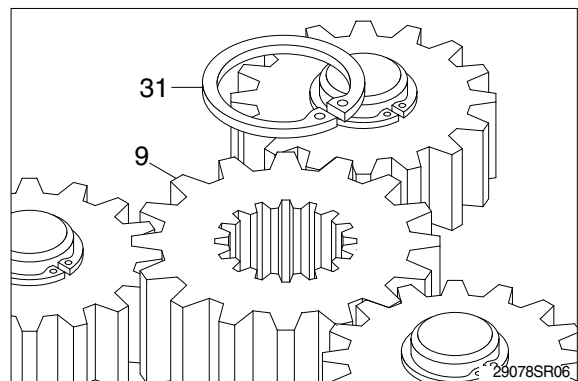

- (5) Tighten two M10 eye bolts to carrier(10) and lift up and remove carrier(10) as subassembly.

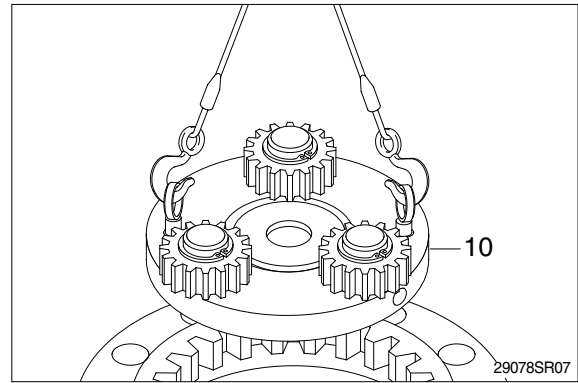

- (6) Disassembling carrier assembly

- ① Remove stop ring(38).
 - ② Remove side plate2(39), planet gear1(8), needle cage(24), side plate1(15) and side plate3(17).
 - ③ Using M8 solid drill, crush spring pin(30) so that the pin1(14) can be removed by hammering.
- ※ Do not reuse spring pin(30).
 - ※ Do not remove pin1(14), carrier(10) and spring pin(30) but in case of replacement.
 - ※ Put matching marks on the planet gear1(8) and the pin1(14) for easy reassembly.

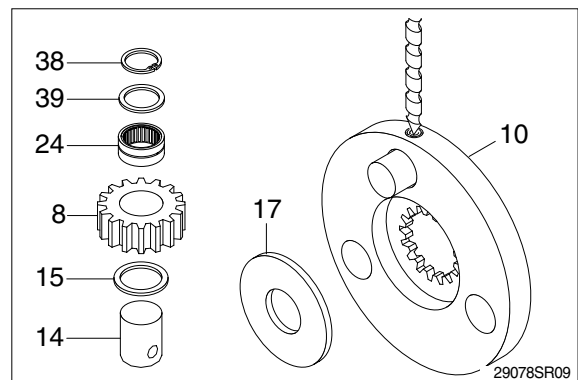
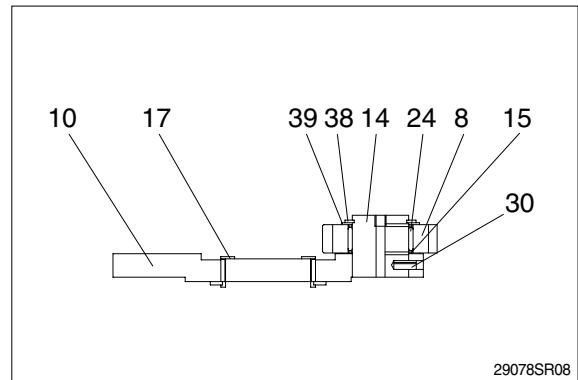

- (7) Remove sun gear2(6) and then remove stop ring(33) when needed.

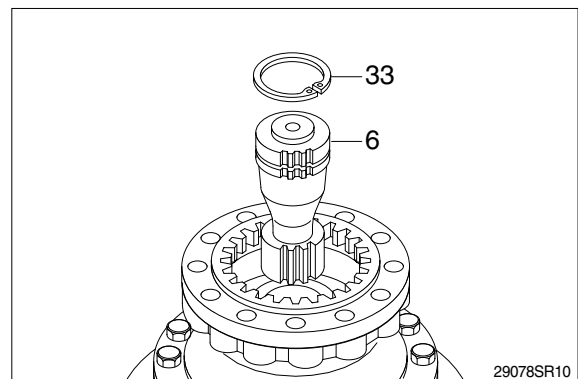

- (8) Remove ring gear(7) from middle casing (2).
 ※ Put matching mark for easy reassembly.

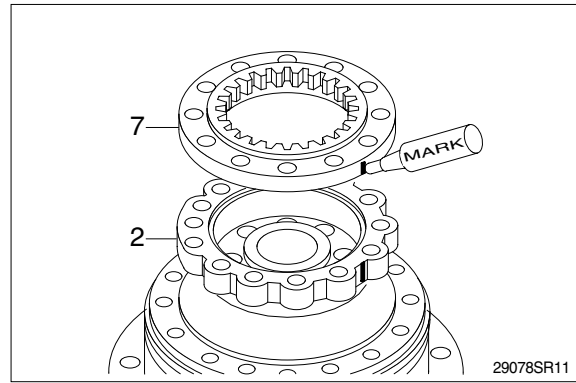

- (9) Loosen the socket bolt(25) and tighten 2 M18 eye bolts to middle casing(2) and then lift up and remove middle casing(2).

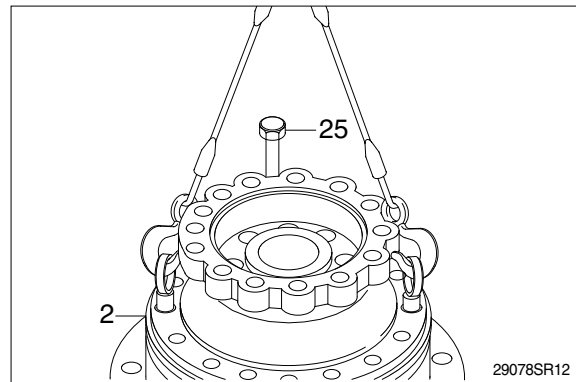

- (10) Remove knock pin(21) and then remove ring gear(4).
 ※ Put marks at the knock pin hole and across the matching line between ring gear(4) and front casing(1) and then remove ring gear(4) for easy reassembly.

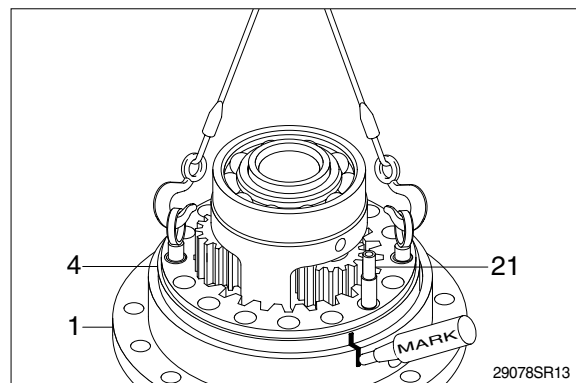

- (11) Using the bearing disassembly tool, remove roller bearing(23).

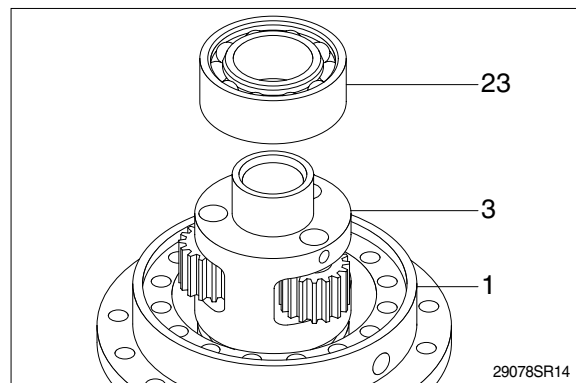

- (12) Tighten three M12 eye bolts to drive shaft (3) and remove drive shaft(3) as subassembly.

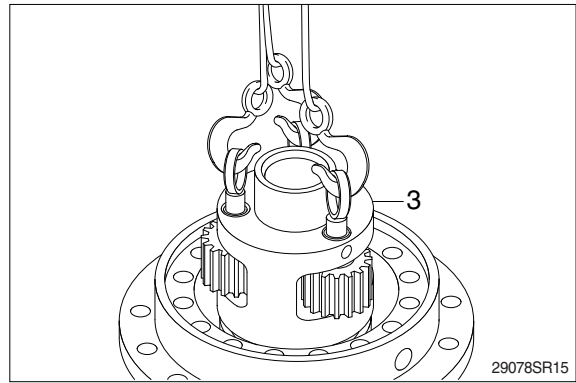

- (13) Disassembling drive shaft assembly.

- ① Insert the spring pin(28) into the pin2(11) by hammering.
 - ② Remove pin2(11), thrust washer(12), bush2(32) and planet gear2(5) from the drive shaft(3).
- ※ Do not proceed and but in case of replacement.
 - ※ Thrust button(13) is assembled in the drive shaft(3) and when replacement needed, use M8 trimming screw of 25mm depth and remove it.
 - ※ Do not remove roller bearing(22). When replacement needed, exchange the roller bearing(22) with drive shaft assembled.

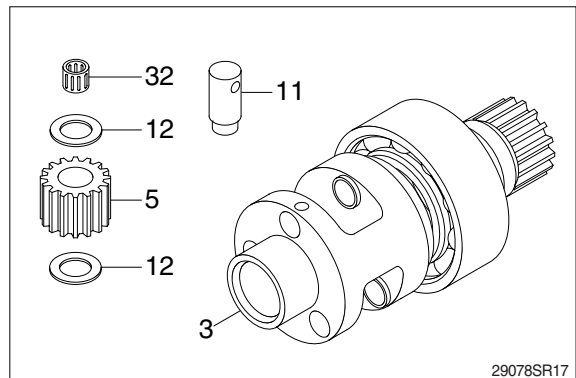
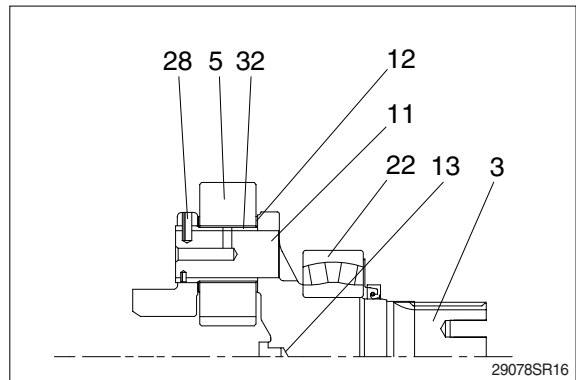

- (14) Remove oil seal(27) from the front casing (1).

- ※ Do not reuse oil seal once removed.

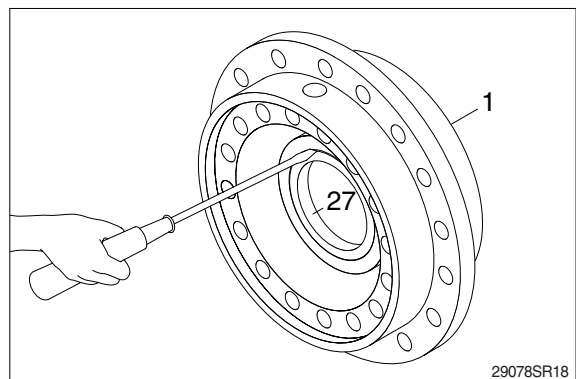

3) ASSEMBLY

(1) Assembling drive shaft assembly.

- ① Soak the roller bearing(22) in boiled oil (80~100°C) and then take out and install it to the drive shaft(3).

※ Confirm assembly coincidence.

- ② Put pinion shaft of drive shaft(3) downwards.

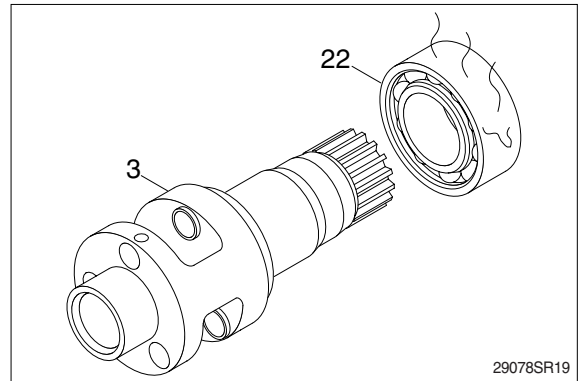

- ③ Assemble thrust button(13) into the drive shaft(3) hole.

※ Depth from the drive shaft(3) outer section to the thrust button(13) is 135mm.

※ Take care not to damage oil seal.

- ④ Assemble bush2(32) and two thrust washers(12) to the planet gear2(5) and then install them to the drive shaft(3).

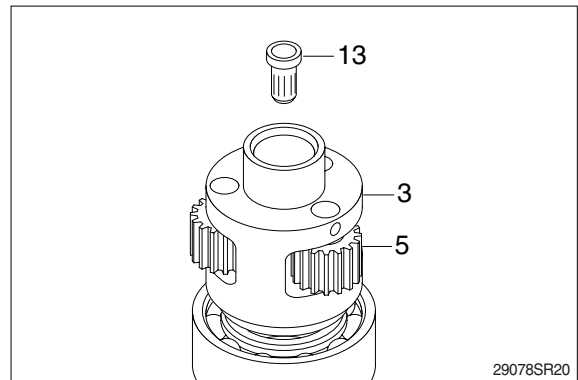

- ⑤ Assemble pin2(11) to the drive shaft(3) and then press the spring pin(28) into the pin2(11) by hammering.

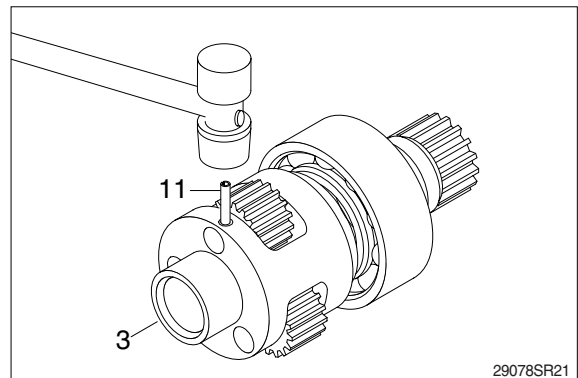

- ⑥ Heat the roller bearing(23) in the boiled oil and the take out and assemble it to the drive shaft(3).

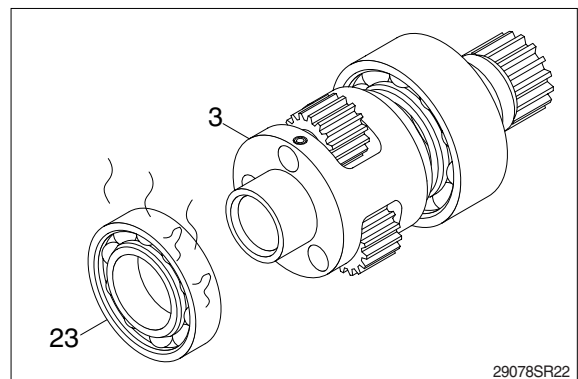

- (2) Fit oil seal(27) to the inside of front casing (1).

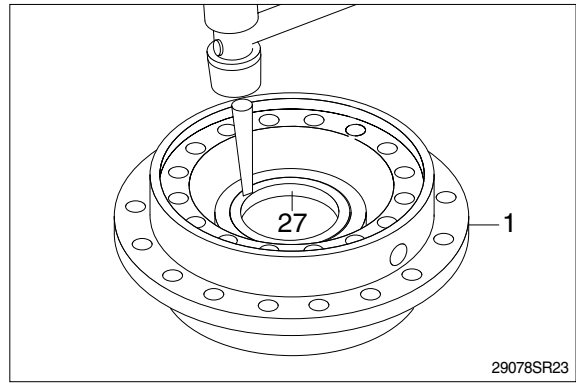

- (3) Mount drive shaft assembly to the front casing(1).
※ Take care not to damage oil seal(27).
※ Assemble drive shaft straightly to the front casing(1).

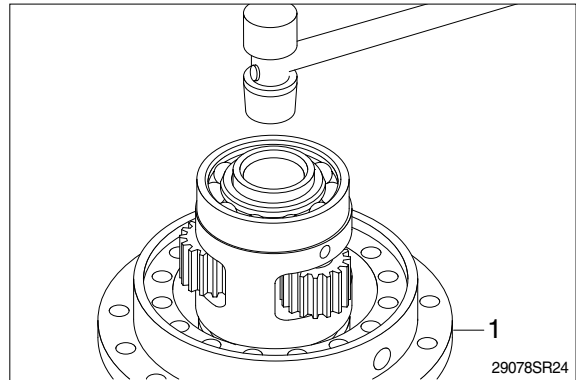

- (4) Apply loctite to the front casing(1) and then coincide the matching mark and assemble ring gear2(4).

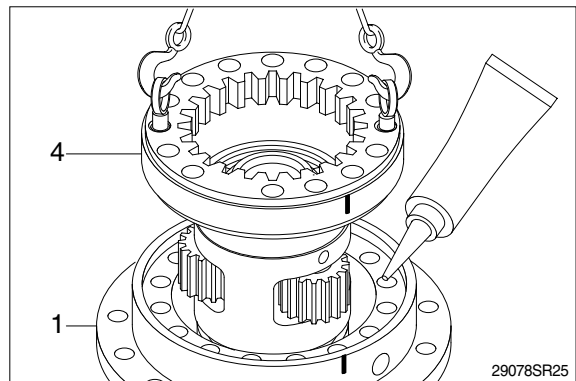

- (5) Hammer 4 knock pins(21) around the front casing(1).

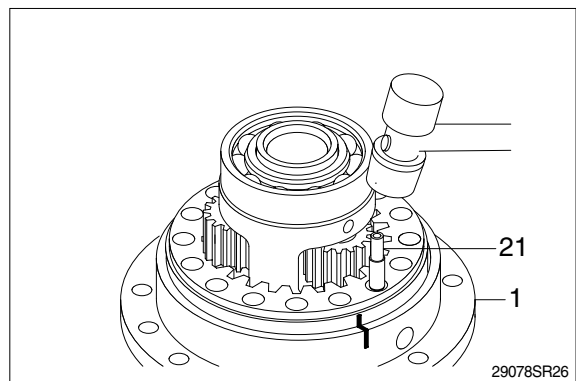

- (6) Apply loctite to the ring gear2(4) and then mount middle casing(2) on the front casing(1).

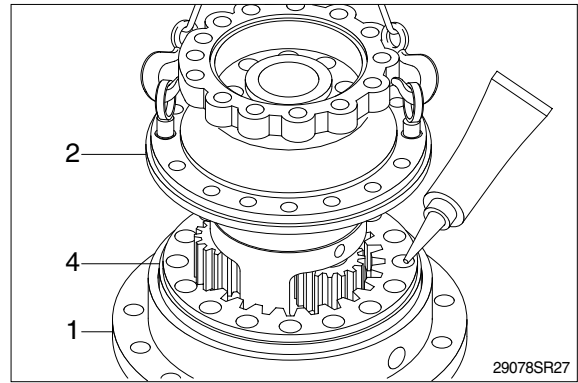

- (7) Tighten socket bolts(25) around the middle casing(2).

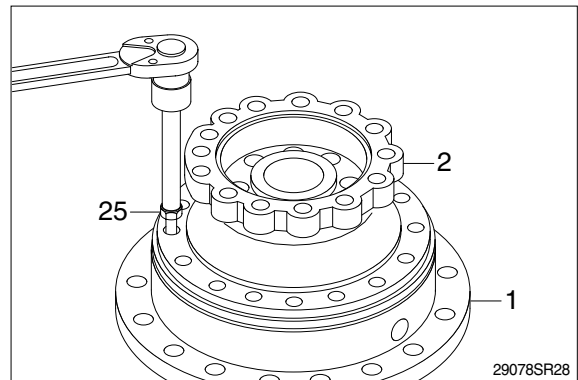

- (8) Assemble stop ring(33) to the sun gear2 (6) and then insert sun gear2(6) into the drive shaft(3).

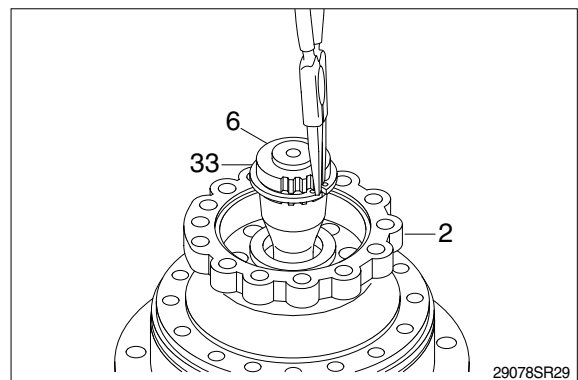

- (9) Apply loctite to the tapped holes of the middle casing(2) and then assemble ring gear1(7).

There is just one tapped hole which has different pitch value.

Don't fail to coincide this hole.

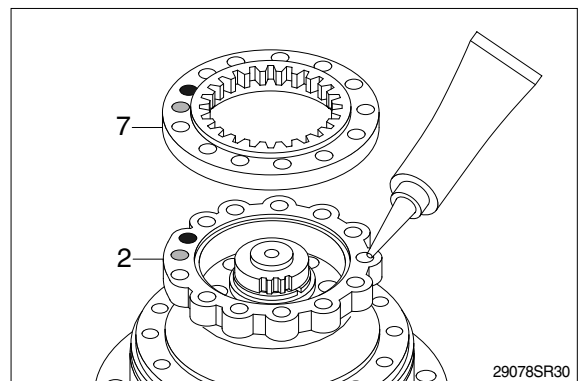

(10) Assembling carrier assembly.

- ① Assemble the pin1(14) to the carrier(10) and then press the spring pin(30) by hammering.
- ② Punch 2 points of the spring pin(30) lip.
- ③ Assemble side plate3(17) onto the center of the carrier(10) and then assemble side plate1(15) to the pin1(14).
- ④ Assemble needle gauge(24) and planet gear1(8) to the pin1(14).

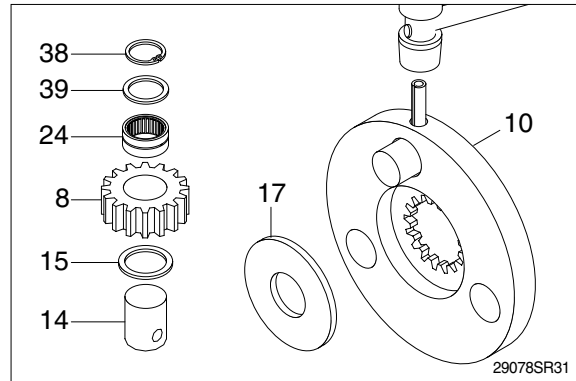

- ⑤ Install side plate2(39) and stop ring(38) to the pin1(14).

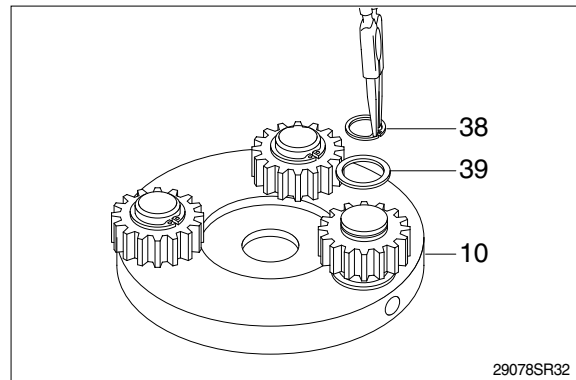

(11) Assemble carrier(10) correctly so that the side plate3(17) can be fixed on the sun gear2(6).

- (12) Assemble sun gear1(9) onto the side plate 3(17).

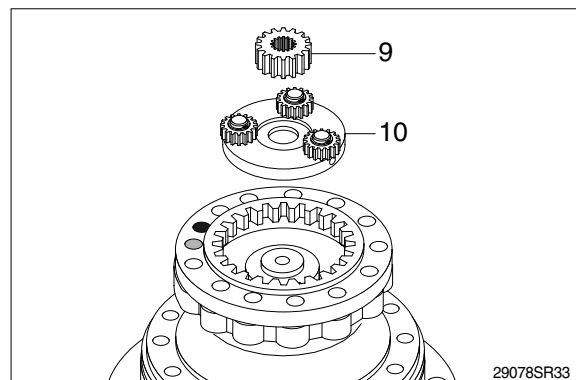

(13) Assemble stop ring(31) to the drive shaft of the swing motor.

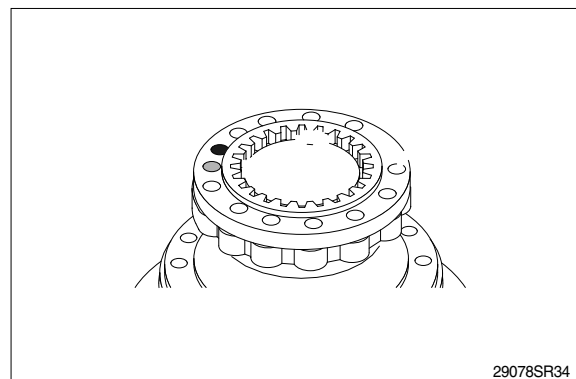

(14) Apply loctite to the tapped holes of the ring gear(17) and then mount swing motor.

※ Don't fail to coincide the gauge bar hole.
Tighten socket bolts(26) around the swing motor.

· Tightening torque : 34kgf · m(246lbf · ft)

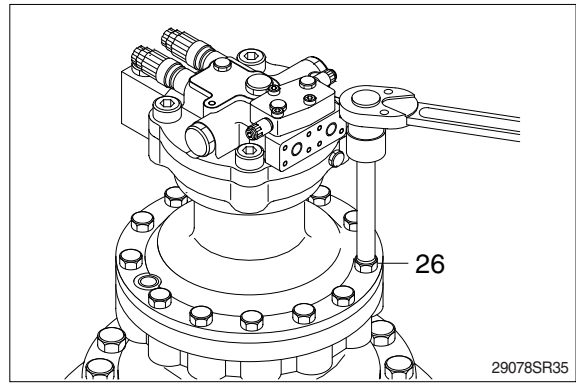

(15) Assemble pressure plug(29), gauge bar(18) and gauge pipe(19).

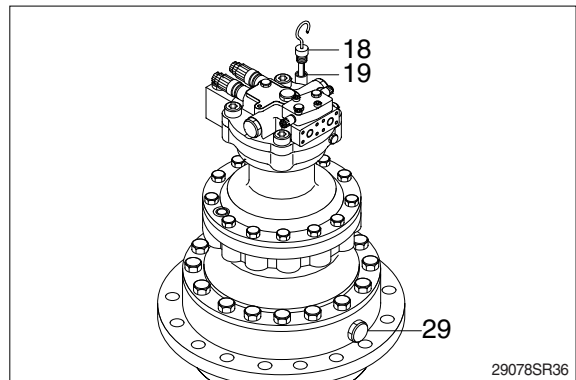

(16) Turn the swing motor assembly upside down and install spacer ring(20) and pinion gear(35) to drive shaft(3) end.

Assemble lock plate(36) on the pinion gear(35).

Assemble 2 lock washers(34) on the lock plate(36) with their 2 holes coincided individually.

Tighten hexagon bolts(37) to the drive shaft(3) and then fold all the lock washer (34) corners over the hexagon bolts(37).

· Tightening torque : 24kgf · m(173lbf · ft)

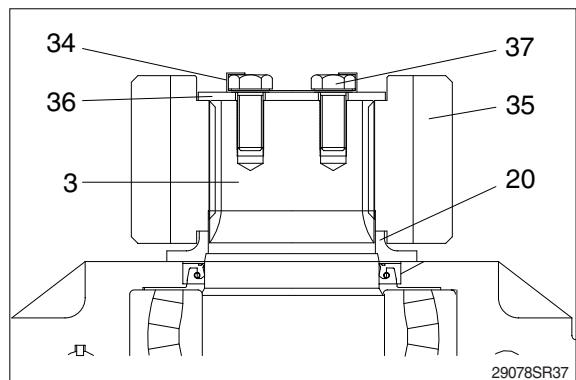

(17) Inject oil into the reduction gear.