

GROUP 4 HYDRAULIC SYSTEM

HYDRAULIC COMPONENTS MOUNTING 1

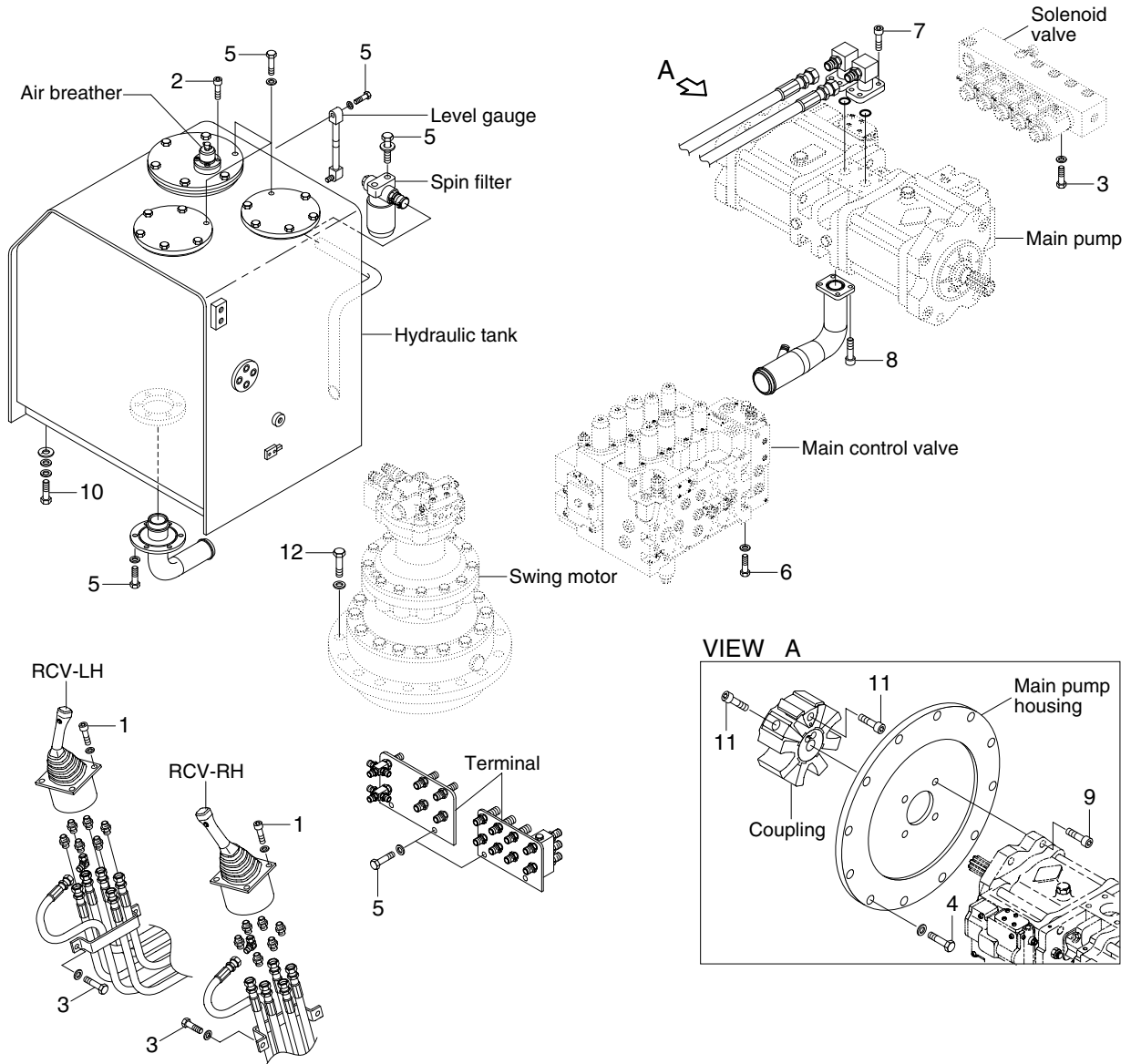

29079CM05

· Tightening torque

Item	Size	kgf · m	lbf · ft
1	M 6×1.0	1.05±0.2	7.6±1.45
2	M 6×1.0	1.44±0.3	10.4±2.2
3	M 8×1.25	2.5±0.5	18.1±3.6
4	M10×1.5	2.81±0.3	20.3±2.2
5	M10×1.5	6.9±1.4	49.9±10.1
6	M12×1.75	12.2±1.3	88.9±9.4

Item	Size	kgf · m	lbf · ft
7	M12×1.75	14.7±2.2	106±15.9
8	M16×2.0	29.7±4.5	215±32.5
9	M20×2.5	42±4.5	304±32.5
10	M20×2.5	46±5.0	333±36
11	M20×2.5	46.5±2.5	336±18.1
12	M20×2.5	57.9±8.7	419±62.9

HYDRAULIC COMPONENTS MOUNTING 2

Double acting attachment piping

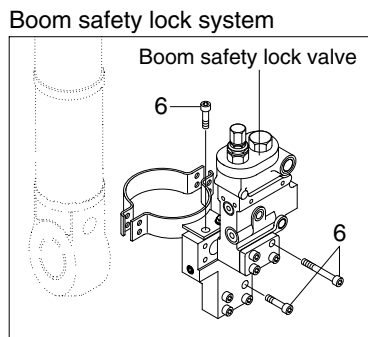
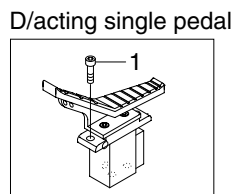
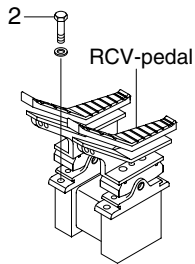
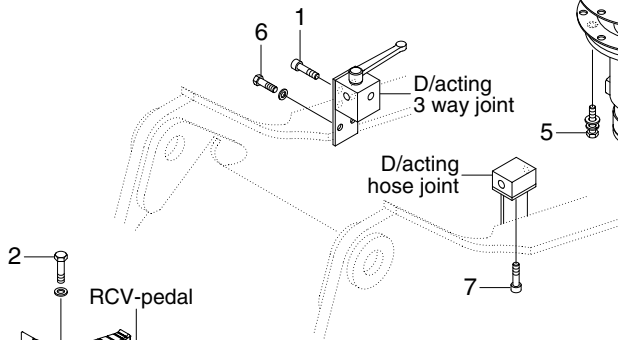
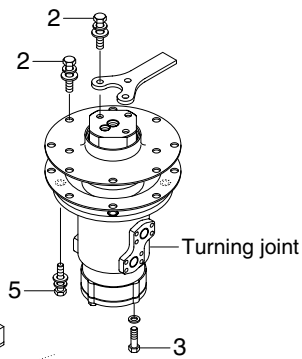
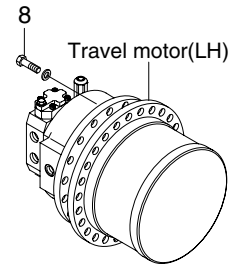
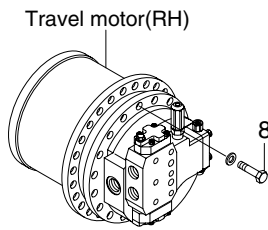
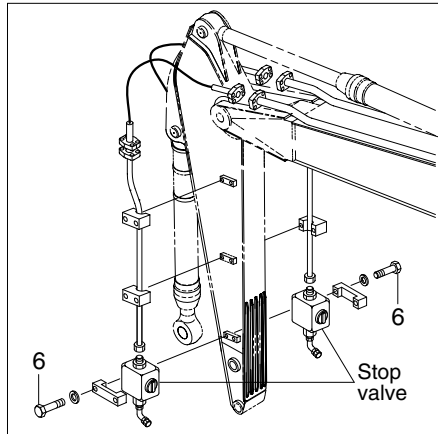

Arm safety lock system

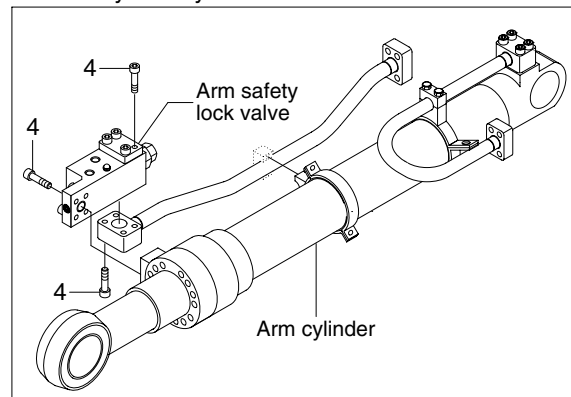

29079CM06

· Tightening torque

Item	Size	kgf · m	lbf · ft
1	M 8×1.25	4.05±0.8	29.3±5.8
2	M10×1.5	6.9±1.4	49.9±10.1
3	M12×1.75	12.3±1.3	88.9±9.4

Item	Size	kgf · m	lbf · ft
4	M12×1.75	12.0±1.3	86.8±9.4
5	M12×1.75	12.8±3.0	92.6±21.7
6	M24×3.0	100±10	723±72.3

HYDRAULIC COMPONENTS MOUNTING 3

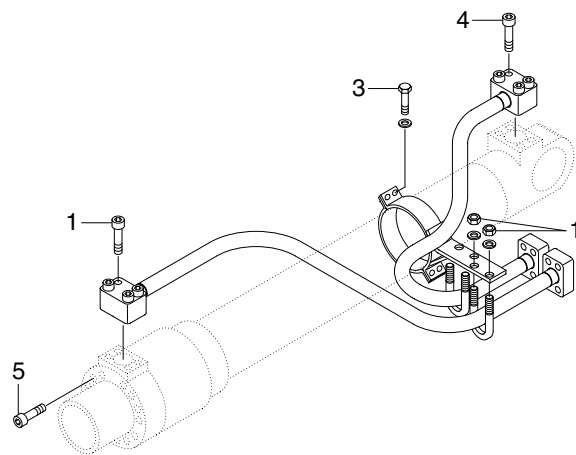

BOOM CYLINDER

Solenoid valve

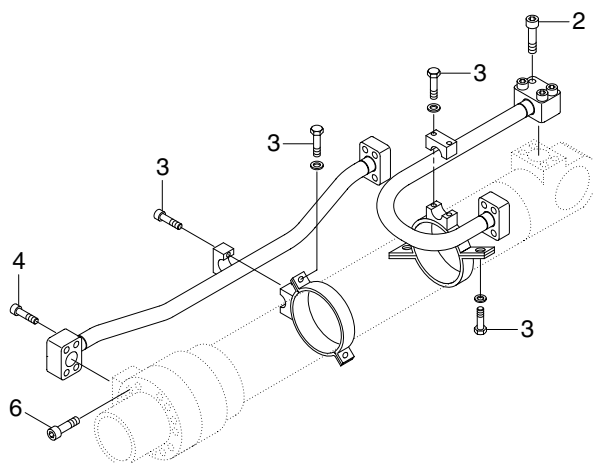
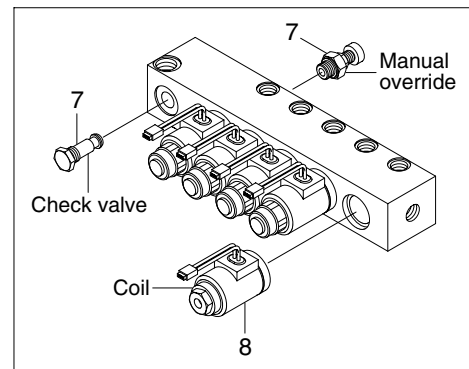

ARM CYLINDER

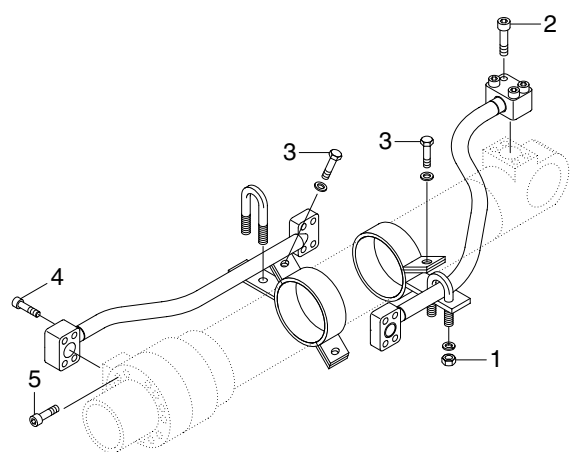

BUCKET CYLINDER

29079CM07

· Tightening torque

Item	Size	kgf · m	lbf · ft
1	M10×1.5	3.2±0.3	23.1±2.2
2	M10×1.5	5.4±0.5	39.1±3.6
3	M12×1.75	5.5±0.6	39.8±4.3
4	M12×1.75	9.4±1.0	68.0±7.2

Item	Size	kgf · m	lbf · ft
5	M18×2.5	32±3.0	232±21.7
6	M20×2.5	46±5.0	333±36.2
7	M22×2.5	4.1	29.6
8	M27×3.0	5.1	36.9