

GROUP 2 ENGINE SYSTEM

ENGINE AND ACCESSORIES MOUNTING

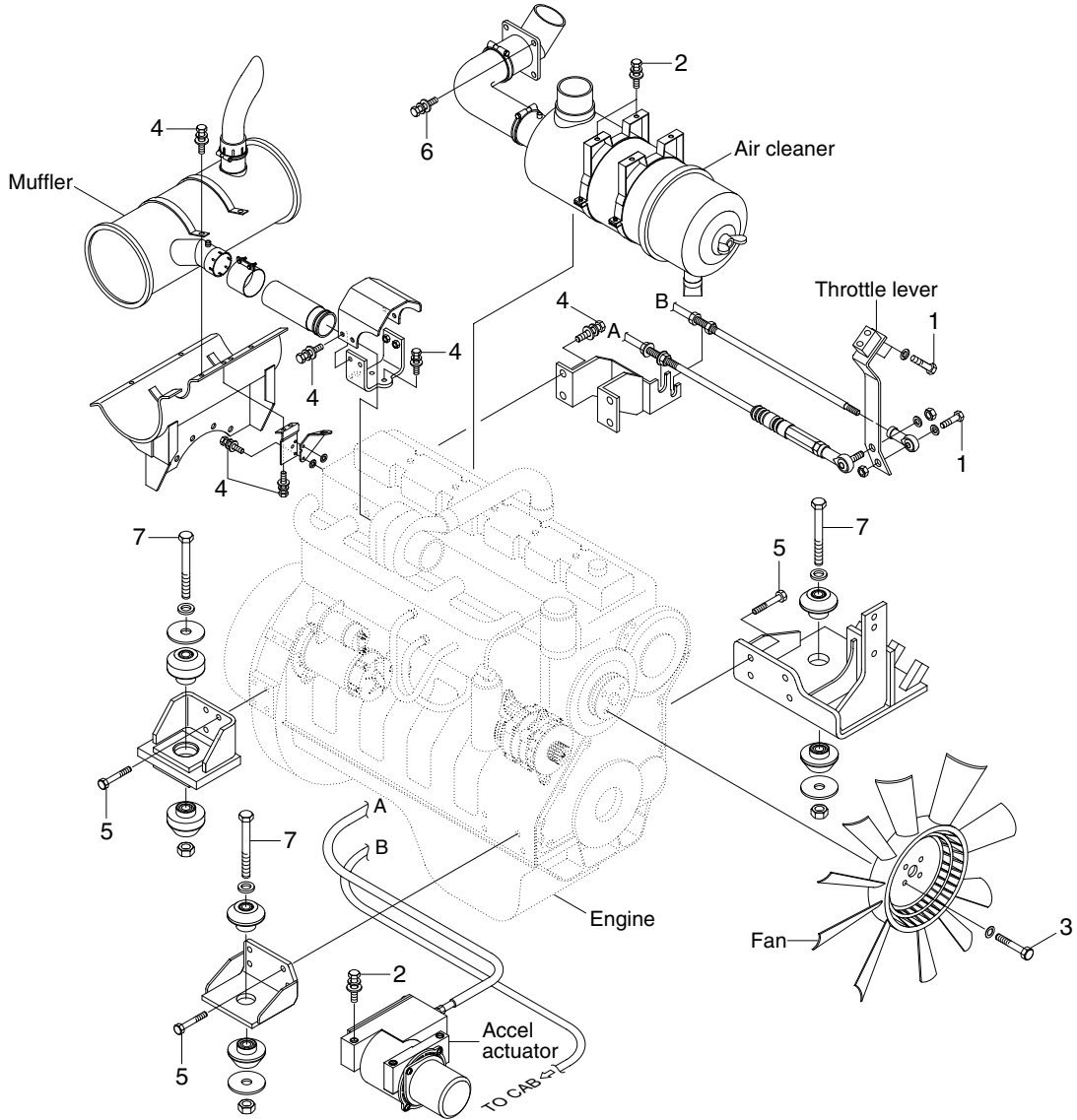

29079CM01

· Tightening torque

Item	Size	kgf · m	lbf · ft
1	M 6×1.0	1.05±0.2	7.6±1.45
2	M 8×1.25	2.5±0.5	18.1±3.6
3	M10×1.5	4.4±0.9	31.8±6.5
4	M10×1.5	6.9±1.4	49.9±10.1

Item	Size	kgf · m	lbf · ft
5	M12×1.75	10.0±2.0	72.3±14.5
6	M12×1.75	12.8±3.0	92.6±21.7
7	M24×3.0	90±7.0	651±51
-	-	-	-

GROUP 3 ELECTRIC SYSTEM

ELECTRIC COMPONENTS MOUNTING 1

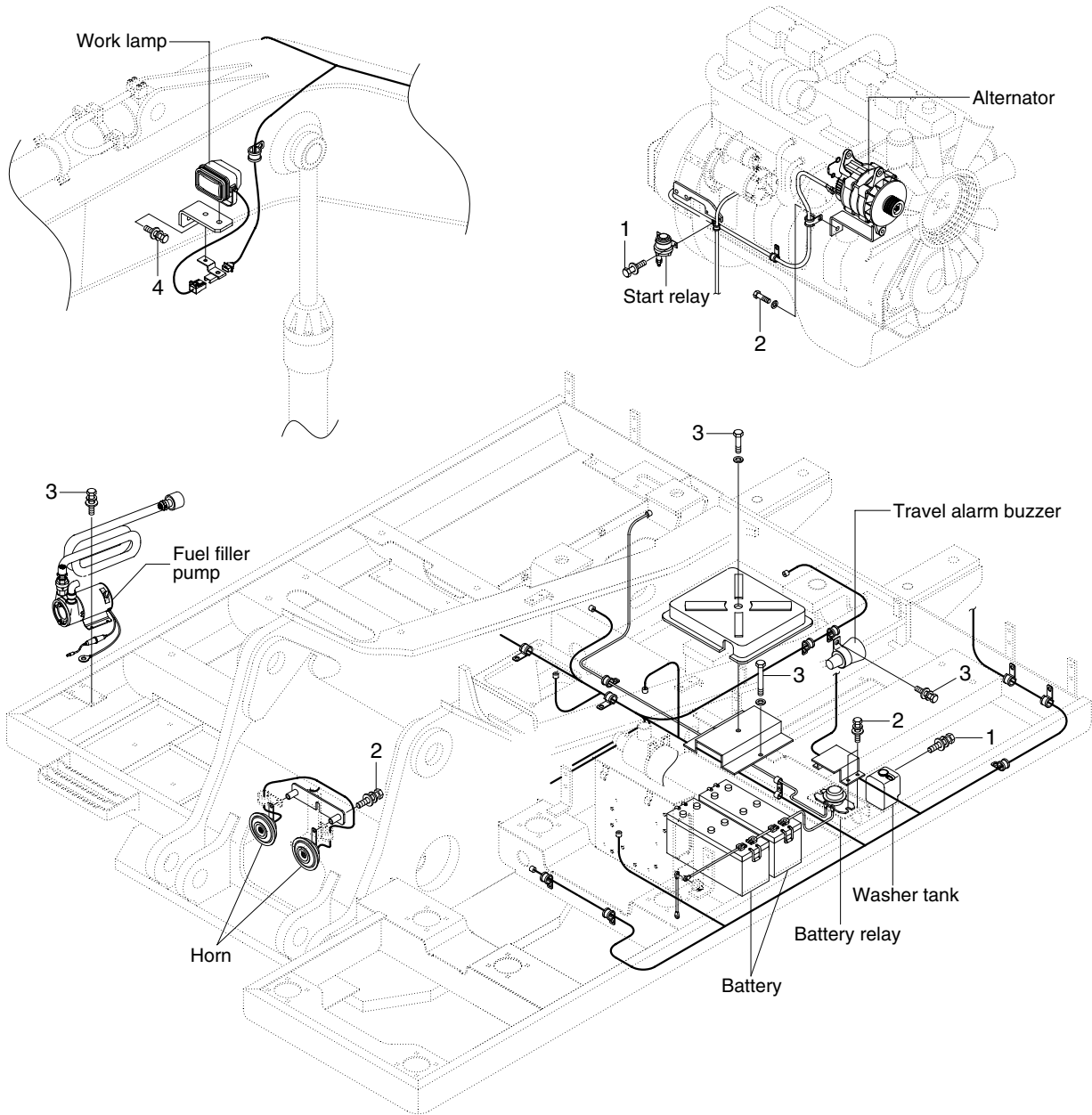

29079CM03

· Tightening torque

Item	Size	kgf · m	lbf · ft
1	M 6×1.0	1.05±0.2	7.6±1.45
2	M 8×1.25	2.5±0.5	18.1±3.6

Item	Size	kgf · m	lbf · ft
3	M10×1.5	6.9±1.4	49.9±10.1
4	M12×1.75	12.8±3.0	92.6±21.7