

GROUP 4 HYDRAULIC SYSTEM

HYDRAULIC COMPONENTS MOUNTING 1

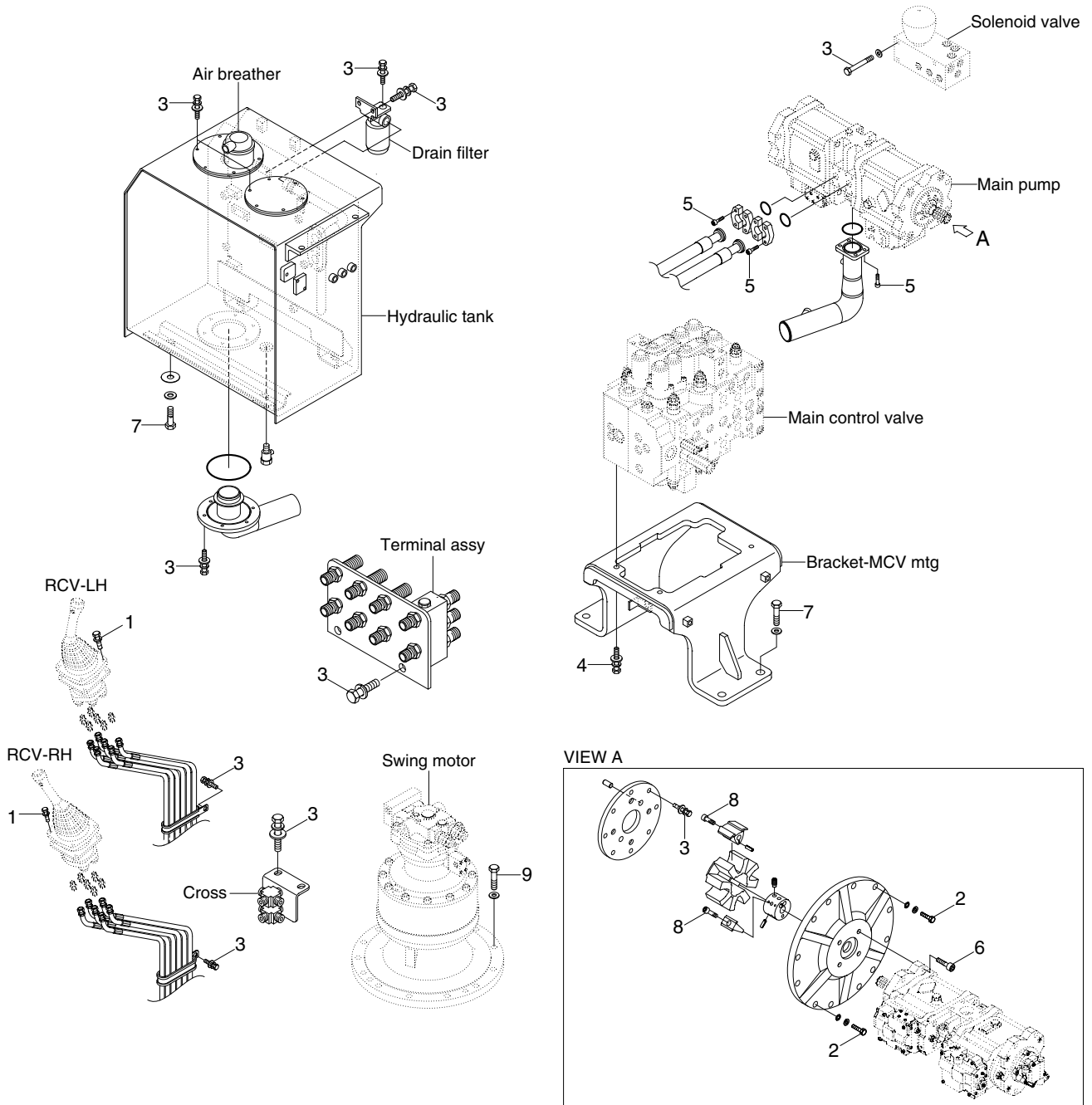

3009SH9CM05

· Tightening torque

Item	Size	kgf · m	lbf · ft
1	M 6 × 1.0	1.05 ± 0.2	7.6 ± 1.45
2	M10 × 1.5	4.8 ± 0.3	34.7 ± 2.2
3	M10 × 1.5	6.9 ± 1.4	49.9 ± 10.1
4	M12 × 1.75	12.3 ± 1.3	88.9 ± 9.4
5	M12 × 1.75	12.8 ± 3.0	92.5 ± 21.6

Item	Size	kgf · m	lbf · ft
6	M20 × 2.5	42 ± 4.5	304 ± 32.5
7	M20 × 2.5	46 ± 5.1	333 ± 36.9
8	M20 × 2.5	32 ± 1.0	231 ± 7.2
9	M20 × 2.5	58.4 ± 6.4	422 ± 46.2

HYDRAULIC COMPONENTS MOUNTING 2

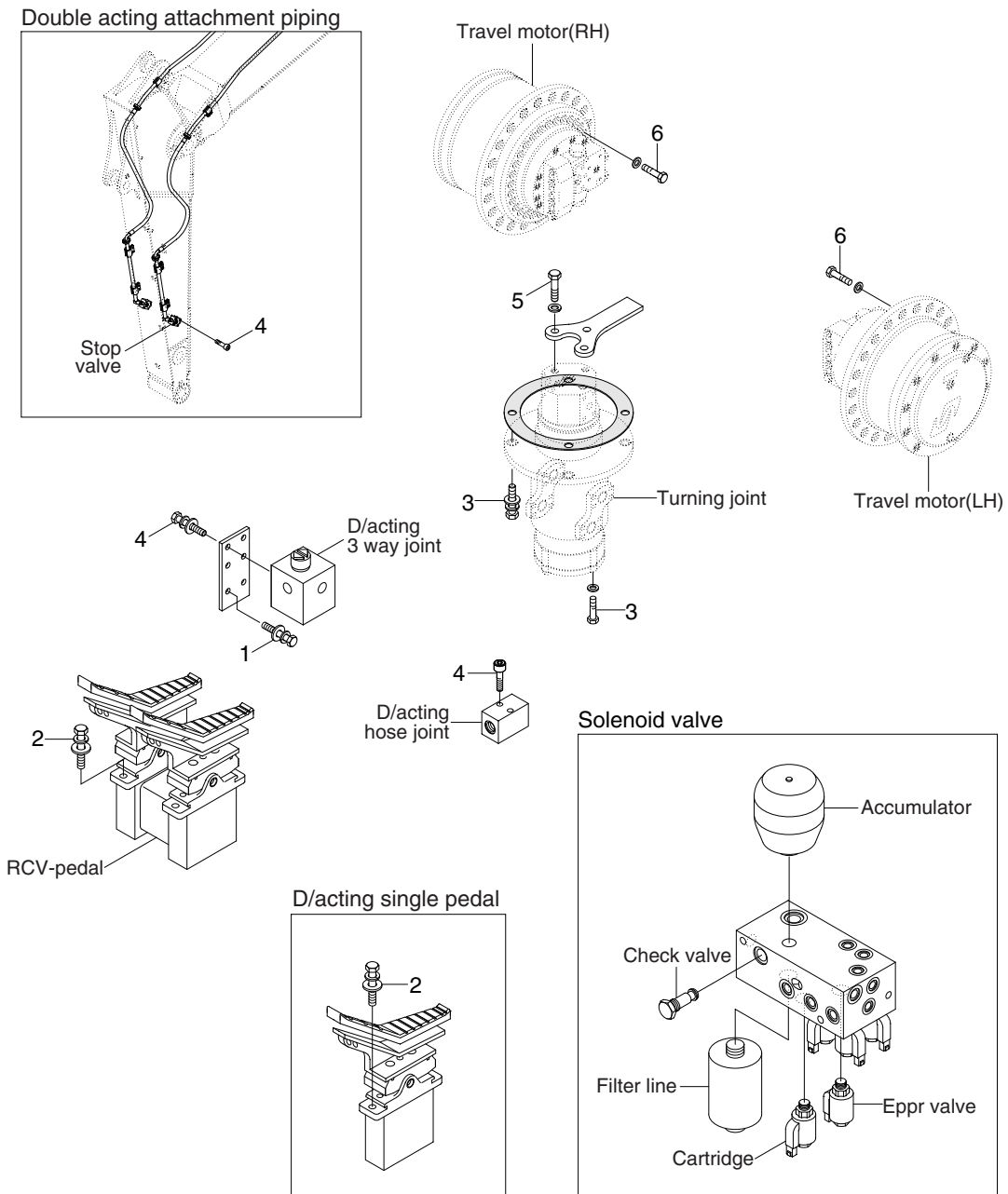

3009SH9CM06

· Tightening torque

Item	Size	kgf · m	lbf · ft
1	M 8×1.25	4.05±0.8	29.3±5.8
2	M10×1.5	6.9±1.4	49.9±10.1
3	M12×1.75	12.3±1.3	88.9±9.4

Item	Size	kgf · m	lbf · ft
4	M12×1.75	12.8±3.0	92.6±21.7
5	M14×2.0	19.6±2.9	142±20.9
6	M24×3.0	84±8.0	723±72.3

HYDRAULIC COMPONENTS MOUNTING 3

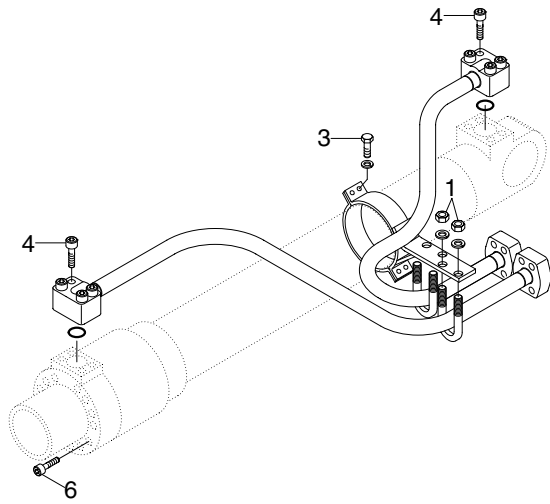

BOOM CYLINDER

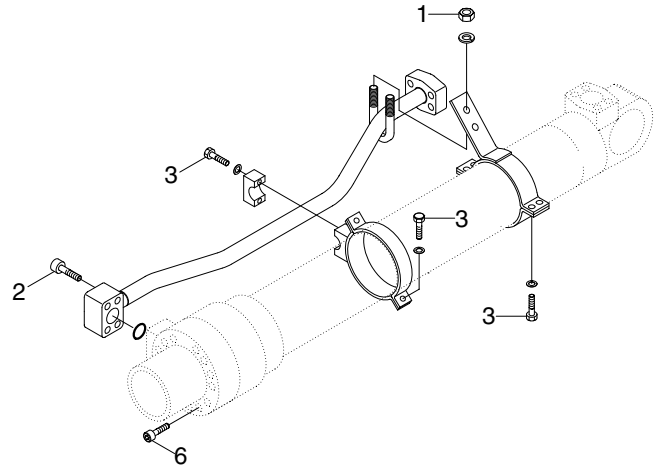

ARM CYLINDER

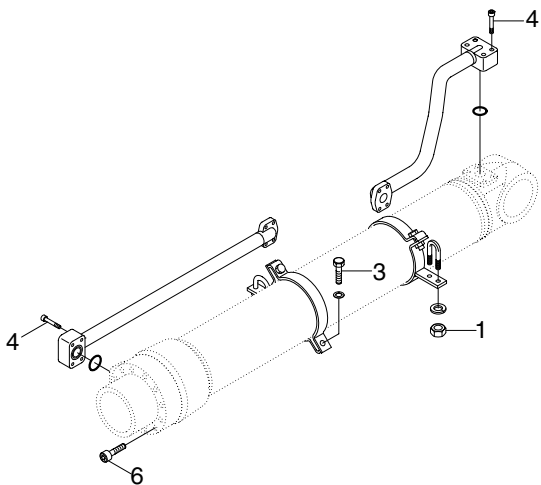

BUCKET CYLINDER

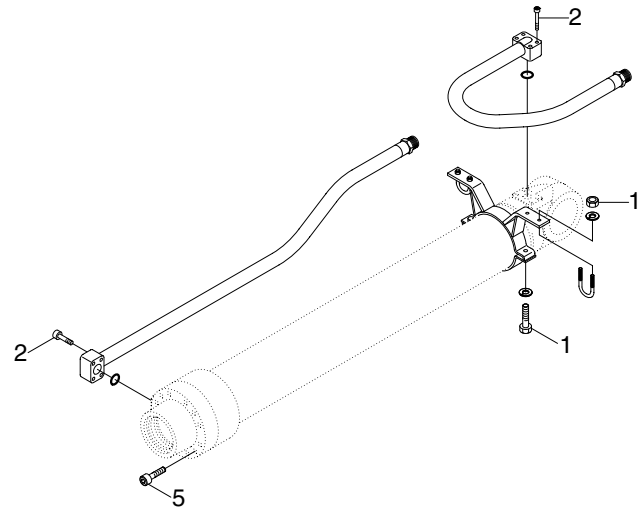

BUCKET CYLINDER (LONG REACH)

3009SH9CM07

· Tightening torque

Item	Size	kgf · m	lbf · ft
1	M10×1.5	3.2±0.3	23.1±2.2
2	M 8×1.25	2.7±0.3	19.5±2.2
3	M12×1.75	5.5±0.6	39.8±4.3
4	M12×1.75	9.4±1.0	68.0±7.2

Item	Size	kgf · m	lbf · ft
5	M16×2.0	23±2.0	166±14.5
6	M18×2.5	32±3.0	232±21.7
7	M20×2.5	46±5.0	333±36.2