

GROUP 2 ENGINE SYSTEM

ENGINE AND ACCESSORIES MOUNTING

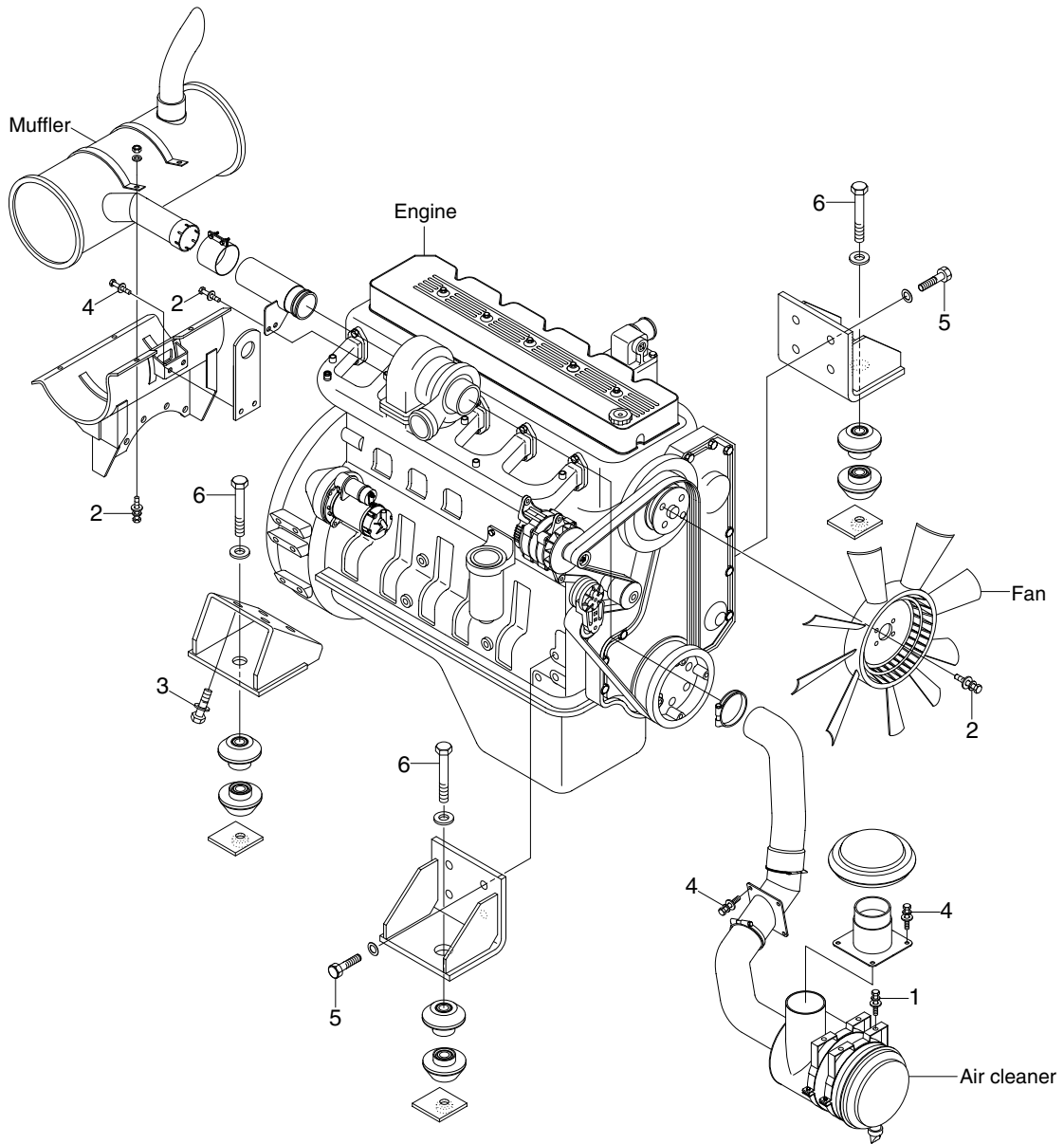

3009SH9CM01

· Tightening torque

Item	Size	kgf · m	lbf · ft
1	M 8×1.25	2.5±0.5	18.1±3.6
2	M10×1.5	6.9±1.4	49.9±10.1
3	M12×1.75	9.8±0.9	70.8±6.5

Item	Size	kgf · m	lbf · ft
4	M12×1.75	12.8±3.0	92.6±21.7
5	M14×2.0	9.8±0.9	70.8±6.5
6	M22×2.5	48±2.0	347±14.4

ENGINE AND ACCESSORIES MOUNTING (ARCTIC MACHINE)

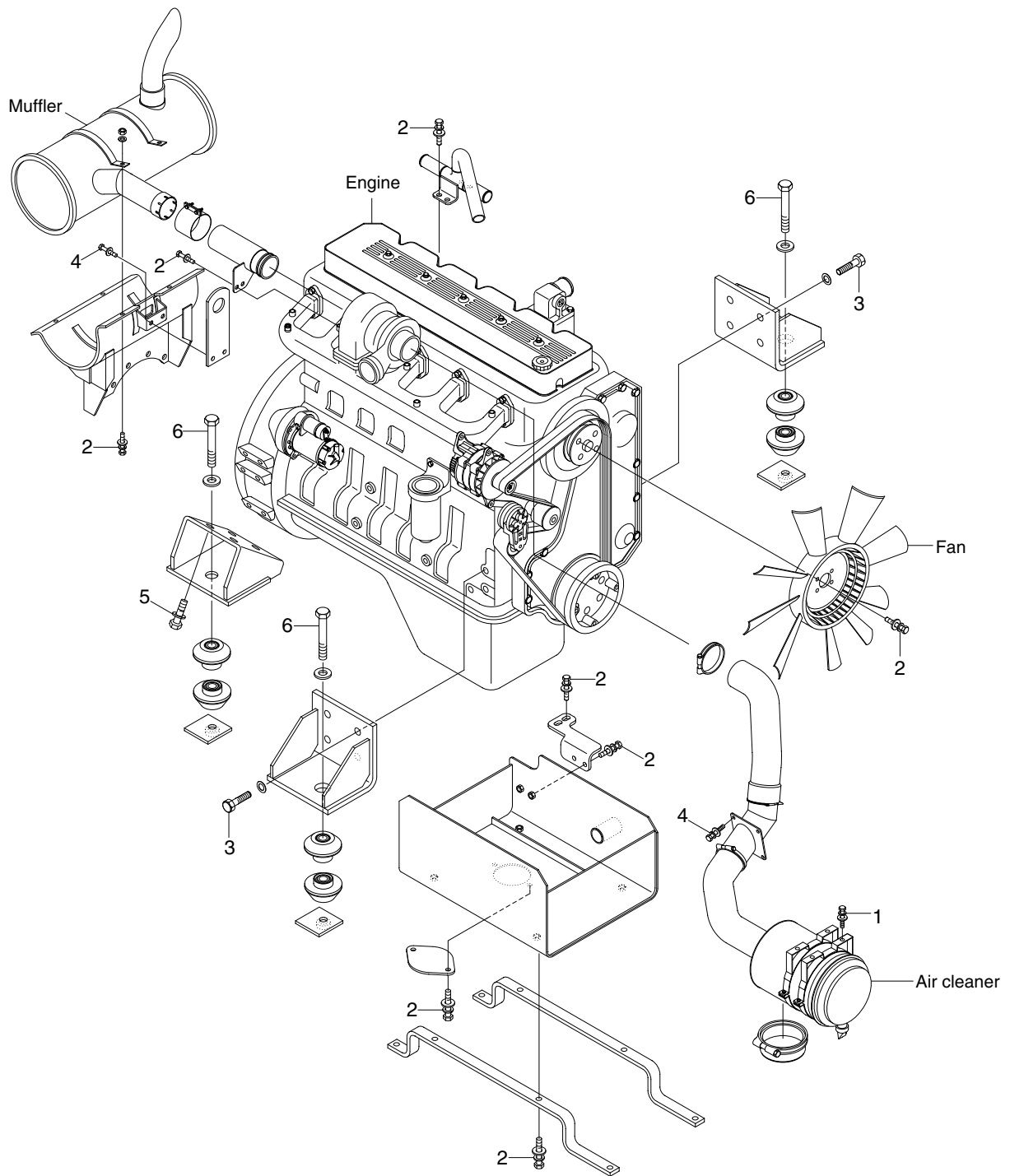

3009SH9CM15

· Tightening torque

Item	Size	kgf · m	lbf · ft
1	M 8×1.25	2.5±0.5	18.1±3.6
2	M10×1.5	6.9±1.4	49.9±10.1
3	M12×1.75	9.8±0.9	70.8±6.5

Item	Size	kgf · m	lbf · ft
4	M12×1.75	12.8±3.0	92.6±21.7
5	M14×2.0	9.8±0.9	70.8±6.5
6	M22×2.5	48±2.0	347±14.4

COOLING SYSTEM AND FUEL TANK MOUNTING

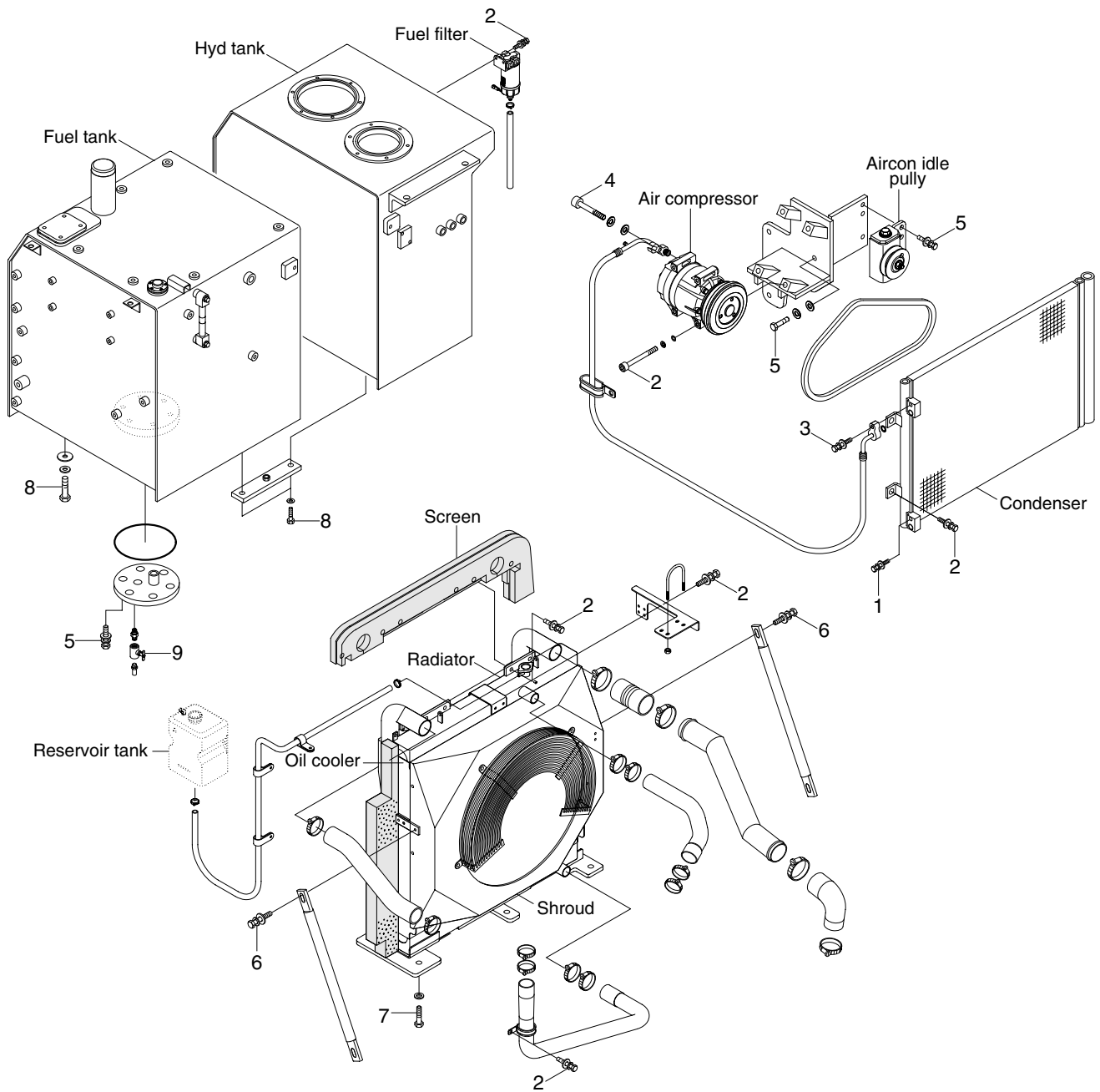

3009SH9CM02

· Tightening torque

Item	Size	kgf · m	lbf · ft
1	M 6×1.0	0.5±0.2	3.6±1.45
2	M 8×1.25	2.5±0.5	18.1±3.6
3	M 8×1.25	1.3±0.2	9.4±1.45
4	M10×1.25	5.0±0.2	36.1±1.45
5	M10×1.5	6.9±1.4	49.9±10.1

Item	Size	kgf · m	lbf · ft
6	M12×1.75	12.8±3.0	92.6±21.7
7	M16×2.0	29.7±4.5	215±32.5
8	M20×2.5	57.9±8.7	419±62.9
9	-	2.3±0.6	16.6±4.3